

CHAPTER ONE

GENERAL INFORMATION

This detailed and comprehensive manual covers 1986-2003 XL/XLH Sportster models. The text provides complete information on maintenance, tune-up, repair and overhaul. Hundreds of photos and drawings guide the reader through every job.

A shop manual is a reference tool and as in all Service manuals, the chapters are thumb tabbed for easy reference. Important items are indexed at the end of the book. All procedures, tables and figures are designed for the reader who may be working on the motorcycle for the first time. Frequently used specifications and capacities from individual chapters are summarized in the *Quick Reference Data* at the front of this manual.

MANUAL ORGANIZATION

All dimensions and capacities are expressed in U.S. standard and metric units of measurement.

Specifications, when applicable, are listed in the tables at the end of each chapter.

This chapter covers shop safety, tool use, service fundamentals and shop supplies. **Tables 1-12** at the end of the chapter include the following:

1. Model designations.

2. General motorcycle dimensions.
3. Motorcycle weight.
4. Gross vehicle weight.
5. Fuel tank capacity.
6. General torque recommendations.
7. Conversion formulas.
8. Technical abbreviations.
9. U.S. standard tap and drill sizes.
10. Metric tap and drill sizes.
11. Decimal and metric equivalents.
12. Special tools.

Chapter Two provides methods for quick and accurate diagnosis of problems. Troubleshooting procedures present typical symptoms and logical methods to pinpoint and repair the problem.

Chapter Three explains all routine maintenance necessary to keep the motorcycle running well. Chapter Three also includes recommended tune-up procedures, eliminating the need to constantly consult the chapters on the various assemblies.

Subsequent chapters describe specific systems such as engine, primary drive and clutch, transmission, emissions, fuel and exhaust systems, the electrical system, suspension, brakes and body. Each disassembly, repair and assembly procedure is discussed in step-by-step form.

WARNINGS, CAUTIONS AND NOTES

The terms, WARNING, CAUTION and NOTE have specific meanings in this manual.

A WARNING emphasizes areas where injury or even death could result from negligence. Mechanical damage may also occur. WARNINGS *are to be taken seriously*.

A CAUTION emphasizes areas where equipment damage could result. Disregarding a CAUTION could cause permanent mechanical damage, though injury is unlikely.

A NOTE provides additional information to make a step or procedure easier or clearer. Disregarding a NOTE could cause inconvenience, but would not cause equipment damage or personal injury.

SAFETY

Professional mechanics can work for years and never sustain a serious injury or mishap. Follow these guidelines and practice common sense to safely service the motorcycle.

1. Do not operate the motorcycle in an enclosed area. The exhaust gasses contain carbon monoxide, an odorless, colorless and tasteless poisonous gas. Carbon monoxide levels build quickly in small enclosed areas and can cause unconsciousness and death in a short time. Make sure the work area is properly ventilated or operate the motorcycle outside.
2. *Never* use gasoline or any flammable liquid to clean parts. Refer to *Handling Gasoline Safely* and *Cleaning Parts* in this section.
3. *Never* smoke or use a torch in the vicinity of flammable liquids.
4. If welding or brazing on the motorcycle, remove the fuel tank, carburetor and shocks to a safe distance at least 50 ft. (15 m) away.
5. Use the correct type and size tools to avoid damaging fasteners.
6. Keep tools clean and in good condition. Replace or repair worn or damaged equipment.
7. When loosening a tight fastener, be guided by what would happen if the tool slips.
8. When replacing fasteners, make sure the new fasteners are of the same size and strength as the original ones.
9. Keep the work area clean and organized.
10. Wear eye protection *any time* eye safety is in question. This includes procedures involving drilling, grinding, hammering, compressed air and chemicals.
11. Wear the correct clothing for the job. Tie up or cover long hair so it can not get caught in moving equipment.
12. Do not carry sharp tools in clothing pockets.
13. Always have an approved fire extinguisher available. Make sure it is rated for gasoline (Class B) and electrical (Class C) fires.
14. Do not use compressed air to clean clothes, the motorcycle or the work area. Debris may be blown into your eyes or skin. *Never* direct compressed air at anyone. Do not al-

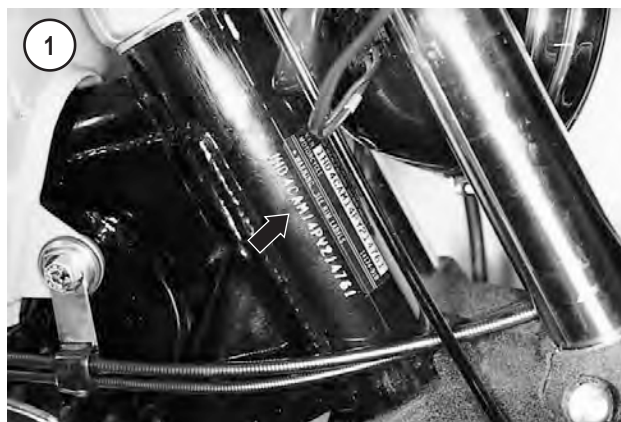

low children to use or play with any compressed air equipment.

15. When using compressed air to dry rotating parts, hold the part so it can not rotate. Do not allow the force of the air to spin the part. The air jet is capable of rotating parts at extreme speed. The part may be damaged or disintegrate, causing serious injury.

16. Do not inhale the dust created by brake pad and clutch wear. These particles may contain asbestos. In addition, some types of insulating materials and gaskets may contain asbestos. Inhaling asbestos particles is hazardous to health.

17. *Never* work on the motorcycle while someone is working under it.

18. When placing the motorcycle on a stand, make sure it is secure before walking away.

Handling Gasoline Safely

Gasoline is a volatile flammable liquid and is one of the most dangerous items in the shop. Because gasoline is used so often, many people forget that it is hazardous. Only use gasoline as fuel for gasoline internal combustion engines. Keep in mind, when working on a motorcycle, gasoline is always present in the fuel tank, fuel line and carburetor. To avoid an accident when working around the fuel system, carefully observe the following precautions:

1. *Never* use gasoline to clean parts. See *Cleaning Parts* in this section.
2. Wear protective gloves to prevent skin contact with gasoline. If your skin contacts gasoline, wash thoroughly with soap and water.
3. When working on the fuel system, work outside or in a well-ventilated area.
4. Do not add fuel to the fuel tank or service the fuel system while the motorcycle is near open flames, sparks or where someone is smoking. Gasoline vapor is heavier than air, it collects in low areas and is more easily ignited than liquid gasoline.
5. Allow the engine to cool completely before working on any fuel system component.

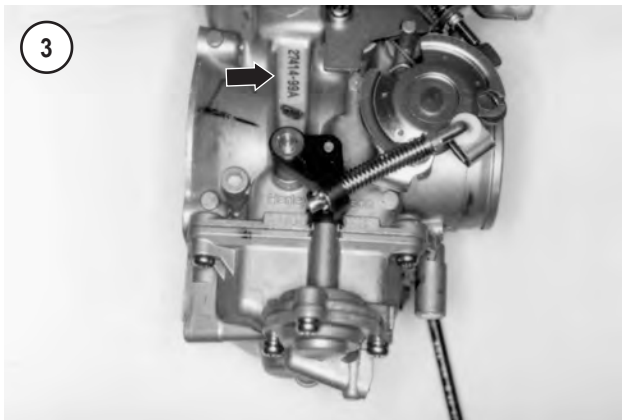
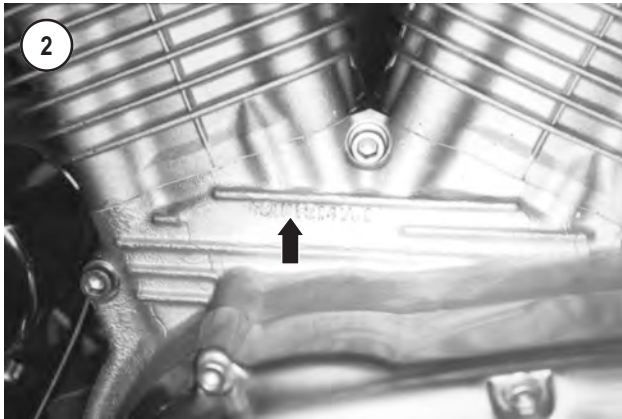

6. When draining the carburetor, catch the fuel in a plastic container and then pour it into an approved gasoline storage device.
7. Do not store gasoline in glass containers. If the glass breaks, an explosion or fire may occur.
8. Immediately wipe up spilled gasoline with rags. Store the rags in a metal container with a lid until they can be properly disposed of, or place them outside in a safe place for the fuel to evaporate.
9. Do not pour water onto a gasoline fire. Water spreads the fire and makes it more difficult to put out. Use a class B, BC or ABC fire extinguisher to extinguish the fire.
10. Always turn off the engine before refueling. Do not spill fuel onto the engine or exhaust system. Do not overfill the fuel tank. Leave an air space at the top of the tank to allow room for the fuel to expand due to temperature fluctuations.

Cleaning Parts

Cleaning parts is one of the more tedious and difficult service jobs performed in the home garage. There are many types of chemical cleaners and solvents available for shop use. Most are poisonous and extremely flammable. To prevent chemical exposure, vapor buildup, fire and serious injury, observe each product warning label and note the following:

1. Read and observe the entire product label before using any chemical. Always know what type of chemical is being used and whether it is poisonous and/or flammable.
2. Do not use more than one type of cleaning solvent at a time. If mixing chemicals is called for, measure the proper amounts according to the manufacturer.
3. Work in a well-ventilated area.
4. Wear protective gloves.
5. Wear safety glasses.
6. Wear a vapor respirator if the instructions call for it.
7. Wash hands and arms thoroughly after cleaning parts.
8. Keep chemical products away from children and pets.
9. Thoroughly clean all oil, grease and cleaner residue from any part that must be heated.
10. Use a nylon brush to clean parts. Metal brushes may cause a spark.
11. When using a parts washer, only use the solvent recommended by the manufacturer. Make sure the parts washer is equipped with a metal lid that will lower in case of fire.

Warning Labels

Most manufacturers attach information and warning labels to the motorcycle. These labels contain instructions that are important to personal safety when operating, servicing, transporting and storing the motorcycle. Refer to the owner's manual for the description and location of labels. Order replacement labels from the manufacturer if they are missing or damaged.

SERIAL NUMBERS

Serial numbers are stamped on various locations on the frame, engine and carburetor. Record these numbers in the *Quick Reference Data* section in the front of the book. Have these numbers available when ordering parts.

The VIN number is stamped on the right side of the steering head (**Figure 1**). The VIN number also appears on a label affixed to the right, front frame downtube.

The engine serial number is stamped on a pad at the left side surface of the crankcase between the cylinders (**Figure 2**). The engine serial number consists of digits used in the VIN number.

The carburetor serial number (**Figure 3**) is located adjacent to the accelerator pump linkage.

NOTE

*In addition to model year designations, Harley-Davidson also uses early and late model designations. Refer to the "Introduction Date and Special Models" information in **Figure 4** to help determine the model identity of a motorcycle. If in doubt, take the VIN number to a dealership.*

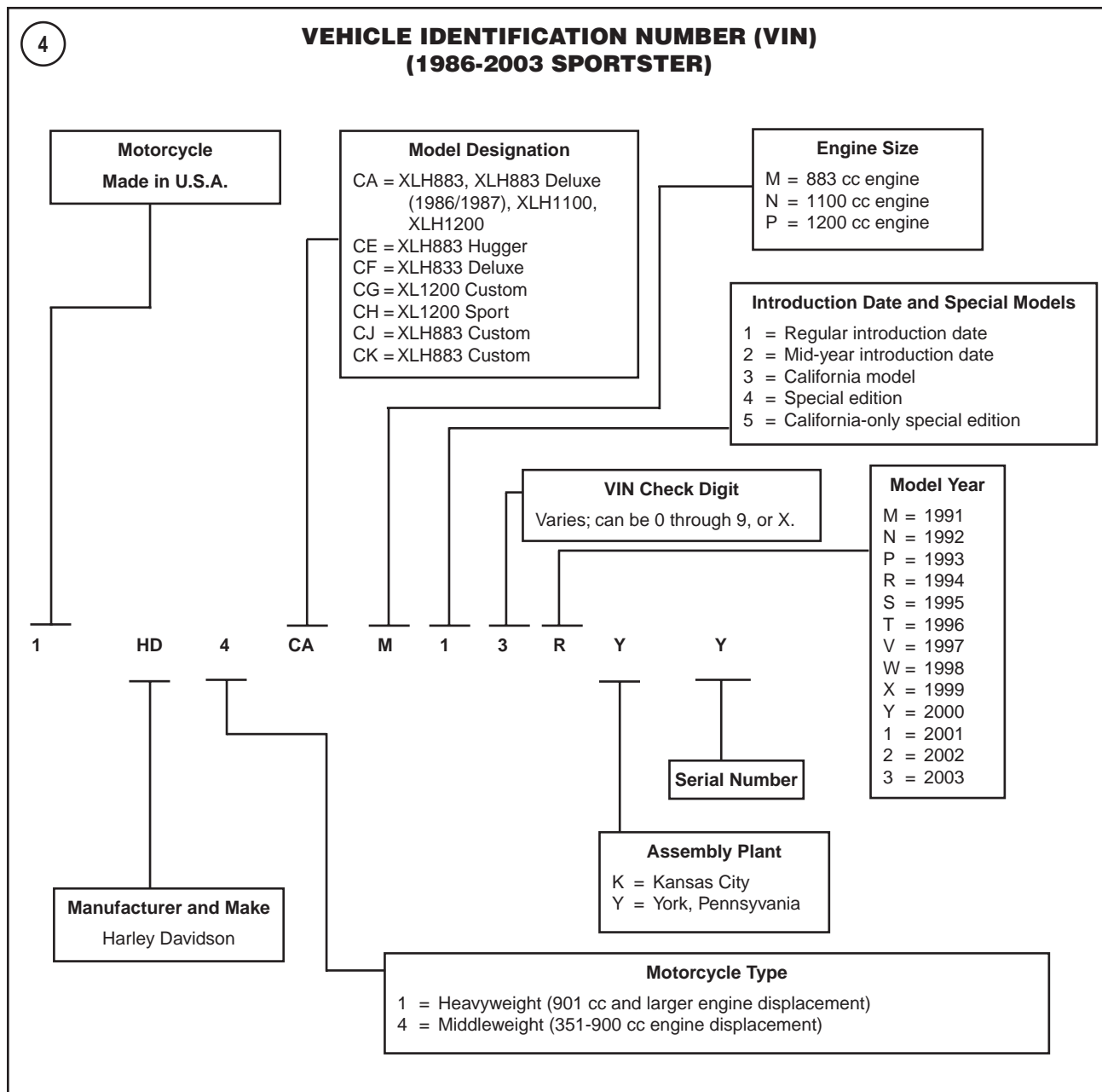

FASTENERS

Proper fastener selection and installation is important to ensure the motorcycle operates as designed and can be serviced efficiently. The choice of original equipment fasteners is not arrived at by chance. Make sure that replacement fasteners meet all the same requirements as the originals.

Threaded Fasteners

WARNING

Do not install fasteners with a strength classification lower than what was originally installed by the manufacturer. Doing so may cause equipment failure and/or damage.

Threaded fasteners secure most of the components on the motorcycle. Most are tightened by turning them clockwise (right-hand threads). If the normal rotation of the component being tightened would loosen the fastener, it may have left-hand threads. If a left-hand threaded fastener is used, it is noted in the text.

Two dimensions are required to match the size of the fastener: the number of threads in a given distance and the outside diameter of the threads.

Two systems are currently used to specify threaded fastener dimensions: the U.S. Standard system and the metric system (**Figure 5**). Pay particular attention when working with unidentified fasteners; mismatching thread types can damage threads.

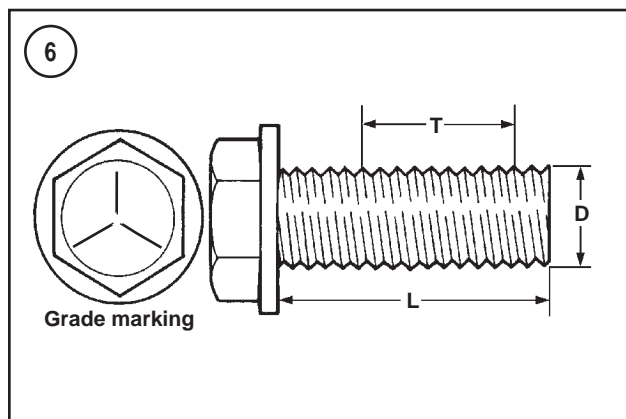
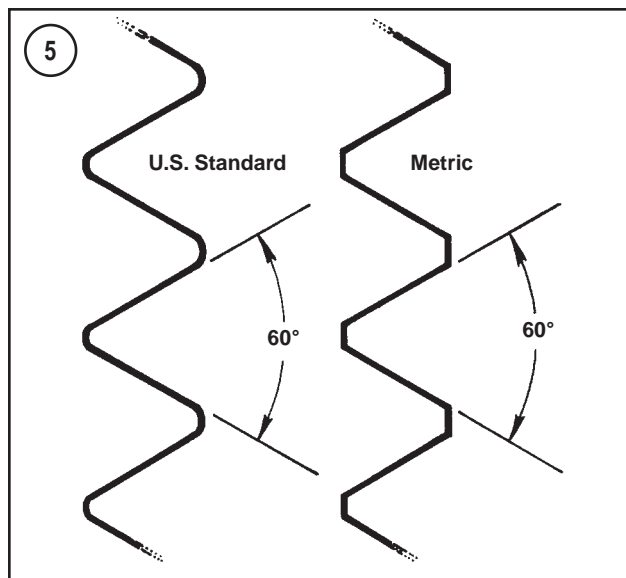
**NOTE**

To ensure that the fastener threads are not mismatched or cross-threaded, start all fasteners by hand. If a fastener is hard to start or turn, determine the cause before tightening with a wrench.

The length (L, **Figure 6**), diameter (D) and number of threads per inch (TPI) (T) classify U.S. Standard screws and bolts. A typical bolt may be identified by the numbers 1/4-20×1-1/2. This indicates the bolt has a 1/4-inch diameter, 20 threads per inch and the length is 1-1/2 inches. Sometimes thread count is noted as either course or fine. Always measure bolt length as shown in L, **Figure 6** to avoid purchasing replacements of the wrong length.

Markings on top of the fastener (**Figure 6**) indicate the strength of U.S. Standard screws and bolts. The greater the number of head markings, the stronger the fastener. Unmarked fasteners are the weakest.

Many screws, bolts and studs are combined with nuts to secure particular components. To indicate the size of a nut, manufacturers specify the internal diameter and the TPI.

The measurement across two flats on a nut or bolt indicates the wrench size.

Torque Specifications

The materials used in the manufacture of the motorcycle may be subjected to uneven stresses if the fasteners of the various subassemblies are not installed and tightened correctly. Fasteners that are improperly installed or work loose can cause extensive damage. It is essential to use an accurate torque wrench, as described in this chapter, with the torque specifications in this manual.

Specifications for torque are provided in foot-pounds (ft.-lb.), inch-pounds (in.-lb.) and Newton-meters (N•m). Refer to **Table 6** for general torque specifications. To use **Table 6**, first determine the size of the fastener as described in this section. Torque specifications for specific components are at the end of the appropriate chapters. Torque wrenches are covered in this chapter.

Self-Locking Fasteners

Several types of bolts, screws and nuts incorporate a system that creates interference between the two fasteners. Interference is achieved in various ways. The most common types are the nylon insert nut and a dry adhesive coating on the threads of a bolt.

Self-locking fasteners offer greater holding strength than standard fasteners, which improves their resistance to vibration. Self-locking fasteners cannot be reused. The material used to form the lock becomes distorted after the initial installation and removal. Discard and replace self-locking fasteners after their removal. Do not replace self-locking fasteners with standard fasteners.

Washers

There are two basic types of washers: flat washers and lockwashers. Flat washers are simple discs with a hole to fit a screw or bolt. Lockwashers are used to prevent a fastener from working loose. Washers can be used as spacers and seals, or to help distribute fastener load and to prevent the fastener from damaging the component.

As with fasteners, when replacing washers make sure the replacement washers are of the same design and quality.

Cotter Pins

A cotter pin is a split metal pin inserted into a hole or slot to prevent a fastener from loosening. In certain applications, such as the rear axle on a motorcycle, the fastener must be secured in this way. For these applications, a cotter pin and castellated (slotted) nut are used.

To use a cotter pin, first make sure the diameter is correct for the hole in the fastener. After correctly tightening the

fastener and aligning the holes, insert the cotter pin through the hole and bend the ends over the fastener (**Figure 7**). Unless instructed to do so, never loosen a tightened fastener to align the holes. If the holes do not align, tighten the fastener just enough to achieve alignment.

Cotter pins are available in various diameters and lengths. Measure length from the bottom of the head to the tip of the shortest pin.

Snap Rings and E-clips

Snap rings (**Figure 8**) are circular-shaped metal retaining clips. They are required to secure parts and gears in place on parts such as shafts, pins or rods. External type snap rings are used to retain items on shafts. Internal type snap rings secure parts within housing bores. In some applications, in addition to securing the component(s), snap rings of varying thickness also determine endplay. These are usually called selective snap rings.

Two basic types of snap rings are used: machined and stamped snap rings. Machined snap rings can be installed in either direction, since both faces have sharp edges. Stamped snap rings (**Figure 9**) are manufactured with a sharp edge and a round edge. When installing a stamped circlip in a thrust application, install the sharp edge facing away from the part producing the thrust (**Figure 10**).

E-clips are used when it is not practical to use a circlip. Remove E-clips with a flat blade screwdriver by prying between the shaft and E-clip. To install an E-clip, center it over the shaft groove and push or tap it into place.

Observe the following when installing snap rings:

1. Remove and install snap rings with circlip pliers. Refer to the *Tools* section in this chapter.
2. In some applications, it may be necessary to replace snap rings after removing them.
3. Compress or expand snap rings only enough to install them. If overly expanded, they lose their retaining ability.
4. After installing a snap ring, make sure it seats completely.
5. Wear eye protection when removing and installing snap rings.

SHOP SUPPLIES

Lubricants and Fluids

Periodic lubrication helps ensure a long service life for any type of equipment. Using the correct type of lubricant is as important as performing the lubrication service, although in an emergency the wrong type is better than not using one. The following section describes the types of lubricants most often required. Make sure to follow the manufacturer's recommendations for lubricant types.

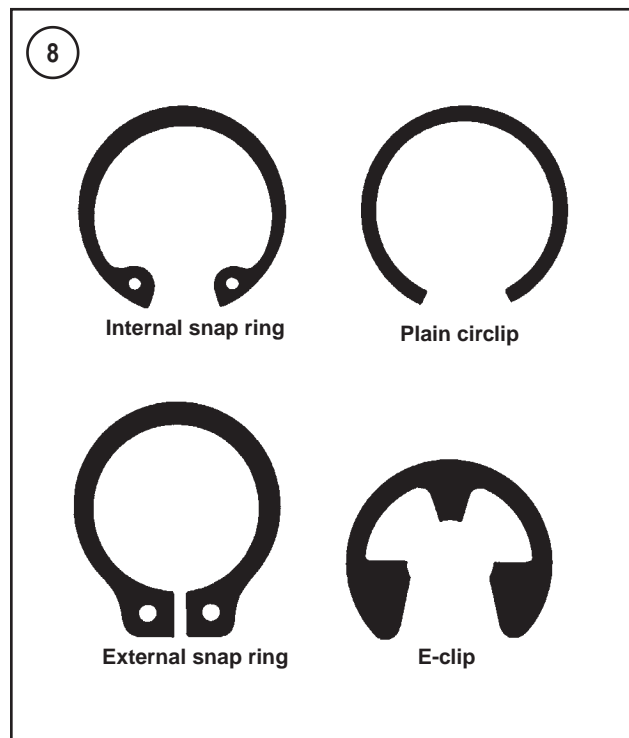
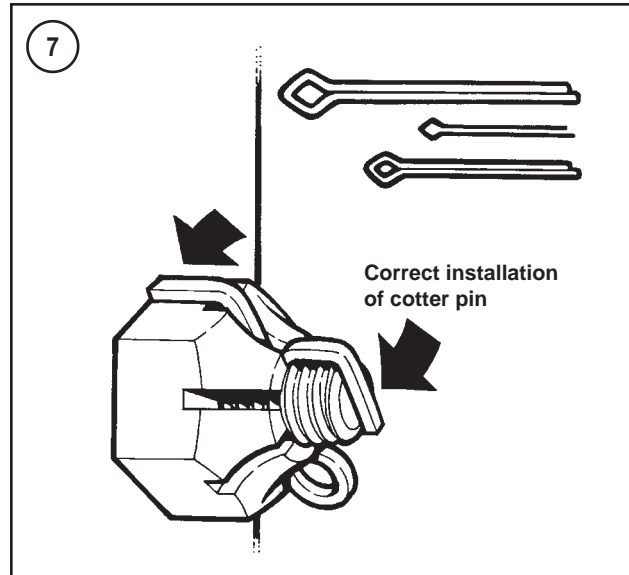

Engine oils

Engine oil is classified by two standards: the American Petroleum Institute (API) service classification and the Society of Automotive Engineers (SAE) viscosity rating. This information is on the oil container label. Two letters indicate the API service classification. The number or sequence of numbers and letter (10W-40 for example) is the oil's viscosity rating. The API service classification and the SAE viscosity index are not indications of oil quality.

The service classification indicates that the oil meets specific lubrication standards. The first letter in the classification, *S*, indicates the oil is for gasoline engines.

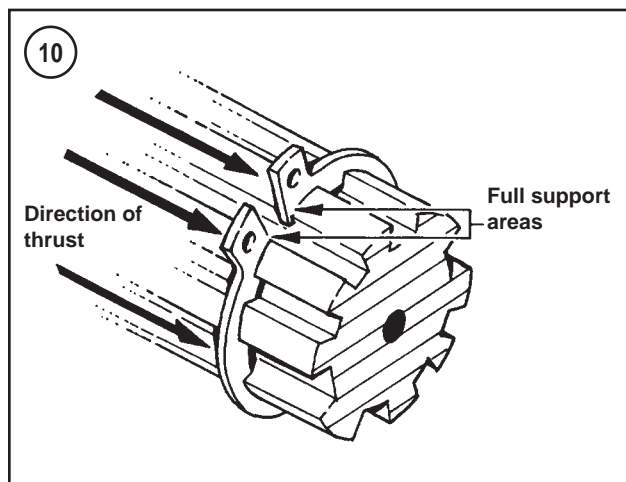
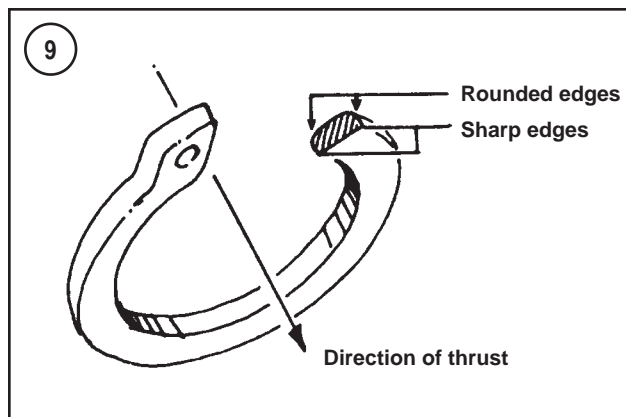

When selecting an API classified oil, make sure the classification is correct (Chapter Three, **Table 3**) and the circular API service label does not indicate the oil is for ENERGY CONSERVING. This type of oil is not designed for motorcycle applications. Using oil with the incorrect classification can cause engine damage.

In addition to the API classification, some oils carry the Japanese Automobile Standards Organization (JASO) classification for use in motorcycle engines. These motorcycle specific oils (JASO T 903 Standard) with the MA (high-friction applications) designation are designed for motorcycle applications.

Always use an oil with a classification recommended by the manufacturer. Using an oil with a different classification can cause engine damage.

Viscosity is an indication of the oil's thickness. Thin oils have a lower number while thick oils have a higher number. Engine oils fall into the 5- to 50-weight range for single-grade oils.

Most manufacturers recommend multi-grade oil. These oils perform efficiently across a wide range of operating conditions. Multi-grade oils are identified by a *W* after the first number, which indicates the low-temperature viscosity.

Engine oils are most commonly mineral (petroleum) based; however, synthetic and semi-synthetic types are being used more frequently. When selecting engine oil, follow the manufacturer's recommendation for type, classification and viscosity when selecting engine oil. Refer to Chapter Three, **Table 3**.

Greases

Grease is lubricating oil with thickening agents added to it. The National Lubricating Grease Institute (NLGI) grades grease. Grades range from No. 000 to No. 6, with No. 6 being the thickest. Typical multipurpose grease is NLGI No. 2. For specific applications, manufacturers may recommend water-resistant grease or one with an additive such as molybdenum disulfide (MoS_2).

Brake fluid

WARNING

Never put a mineral-based (petroleum) oil into the brake system. Mineral oil will cause rubber parts in the system to swell and break apart, resulting in complete brake failure.

Brake fluid is the hydraulic fluid used to transmit hydraulic pressure (force) to the wheel brakes. Brake fluid is classified by the Department of Transportation (DOT). This classification, DOT 5 for example, appears on the fluid container.

Each type of brake fluid has its own definite characteristics. Do not intermix different types of brake fluid as this may cause brake system failure. DOT 5 brake fluid is silicone based. DOT 5 is not compatible with other brake fluids or in systems for which it was not designed. Mixing DOT 5 fluid with other fluids may cause brake system failure. When adding brake fluid, *only* use the fluid recommended by the manufacturer. Refer to Chapter Three, **Table 5**.

Brake fluid will damage any plastic, painted or plated surface it contacts. Use care when working with brake fluid and clean any spills immediately with soap and water.

Hydraulic brake systems require clean and moisture free brake fluid. Never reuse brake fluid. Keep containers and reservoirs properly sealed.

Coolant

Coolant is a mixture of water and antifreeze used to dissipate engine heat. Ethylene glycol is the most common form of antifreeze used. Check the motorcycle manufacturer's recommendations (Chapter Three, **Table 5**) when selecting antifreeze; most require one specifically designed for use in aluminum engines. These types of antifreeze have additives that inhibit corrosion.

Only mix distilled water with antifreeze. Impurities in tap water may damage internal cooling system passages.

Cleaners, Degreasers and Solvents

Many chemicals are available to remove oil, grease and other residue from the motorcycle. Before using cleaning solvents, consider how they will be used and disposed of, particularly if they are not water-soluble. Local ordinances may require special procedures for the disposal of many types of cleaning chemicals. Refer to *Safety* in this chapter for more information on their use.

Use brake parts cleaner to clean brake system components, contact with petroleum-based products will damage seals. Brake parts cleaner leaves no residue. Use electrical contact cleaner to clean electrical connections and components without leaving any residue. Carburetor cleaner is a powerful solvent used to remove fuel deposits and varnish from fuel system components. Use this cleaner carefully, as it may damage finishes.

Generally, degreasers are strong cleaners used to remove heavy accumulations of grease from engine and frame components.

Most solvents are designed to be used with a parts washing cabinet for individual component cleaning. For safety, use only nonflammable or high flash point solvents.

Gasket Sealant

Sealants are often used in combination with a gasket or seal and are occasionally alone. Follow the manufacturer's recommendation when using sealants. Use care when choosing a sealant different from the type originally recommended. Choose sealants based on their resistance to heat, various fluids and their sealing capabilities.

One of the most common sealants is RTV, or room temperature vulcanizing sealant. This sealant cures at room temperature over a specific time period. This allows the repositioning of components without damaging gaskets.

Moisture in the air causes the RTV sealant to cure. Always install the tube cap as soon as possible after applying RTV sealant. RTV sealant has a limited shelf life and will not cure properly if the shelf life has expired. Keep partial tubes sealed and discard them if they have surpassed the expiration date.

Applying RTV sealant

Clean all old gasket residue from the mating surfaces. Remove all gasket material from blind threaded holes; it can cause inaccurate bolt torque. Spray the mating surfaces with aerosol parts cleaner and then wipe with a lint-free cloth. The area must be clean for the sealant to adhere.

Apply RTV sealant in a continuous bead 0.08-0.12 in. (2-3 mm) thick. Circle all the fastener holes unless otherwise specified. Do not allow any sealant to enter these



holes. Assemble and tighten the fasteners to the specified torque within the time frame recommended by the RTV sealant manufacturer.

Gasket Remover

Aerosol gasket remover can help remove stubborn gaskets. This product can speed up the removal process and prevent damage to the mating surface that may be caused by using a scraping tool. Most of these types of products are very caustic. Follow the gasket remover manufacturer's instructions for use.

Threadlocking Compound

CAUTION

Threadlocking compounds are anaerobic and will damage most plastic parts and surfaces. Use caution when using these products in area where plastic components are located.

A threadlocking compound is a fluid applied to the threads of fasteners. After tightening the fastener, the fluid dries and becomes a solid filler between the threads. This makes it difficult for the fastener to work loose from vibration, or heat expansion and contraction. Some threadlocking compounds also provide a seal against fluid leaks.

Before applying threadlocking compound, remove any old compound from both thread areas and clean them with aerosol parts cleaner. Use the compound sparingly. Excess fluid can run into adjoining parts.

Threadlocking compounds are available in different strength, temperature and repair application. Follow the manufacturer's recommendations regarding compound selection.

TOOLS

Most of the procedures in this manual can be carried out with simple hand tools and test equipment familiar to the



home mechanic. Always use the correct tools for the job at hand. Keep tools organized and clean. Store them in a tool chest with related tools organized together.

Quality tools are essential. The best are constructed of high-strength alloy steel. These tools are light, easy to use and resistant to wear. Their working surface is devoid of sharp edges and the tool is carefully polished. They have an easy-to-clean finish and are comfortable to use. Quality tools are a good investment.

When purchasing tools to perform the procedures covered in this manual, consider the tool's potential frequency of use. If starting a new tool kit, consider purchasing a basic tool set from a quality tool supplier. These sets are available in many tool combinations and offer substantial savings when compared to individually purchased tools. As work experience grows and tasks become more complicated, specialized tools can be added.

Some of the procedures in this manual specify special tools. Refer to **Table 12**. In most cases, the tool is illustrated in use. Well-equipped mechanics may be able to substitute similar tools or fabricate a suitable replacement. However, in some cases, the specialized equipment or expertise may make it impractical for the home mechanic to attempt the procedure. When necessary, such operations are identified in the text with the recommendation to have a dealership or specialist perform the task. It may be less expensive to have a professional perform these jobs, especially when considering the cost of the equipment.

The manufacturer's part number is provided for many of the tools mentioned in this manual. These part numbers are correct at the time of original publication. The publisher cannot guarantee the part number or the tools in this manual will be available in the future.

Screwdrivers

Screwdrivers of various lengths and types are mandatory for the simplest tool kit. The two basic types are the slotted tip (flat blade) and the Phillips tip. These are available in sets that often include an assortment of tip sizes and shaft lengths.

As with all tools, use a screwdriver designed for the job. Make sure the size of the tip conforms to the size and shape of the fastener. Use them only for driving screws. Never use a screwdriver for prying or chiseling metal. Repair or replace worn or damaged screwdrivers. A worn tip may damage the fastener, making it difficult to remove.

Wrenches

Open-end, box-end and combination wrenches (**Figure 11**) are available in a variety of types and sizes.

The number stamped on the wrench refers to the distance between the work areas. This size must match the size of the fastener head.

The box-end wrench is an excellent tool because it grips the fastener on all sides. This reduces the chance of the tool slipping. The box-end wrench is designed with either a 6- or 12-point opening. For stubborn or damaged fasteners, the 6-point provides superior holding ability by contacting the fastener across a wider area at all six edges. For general use, the 12-point works well. It allows the wrench to be removed and reinstalled without moving the handle over such a wide arc.

An open-end wrench is fast and works best in areas with limited overhead access. It contacts the fastener at only two points, and is subject to slipping under heavy force, or if the tool or fastener is worn. A box-end wrench is preferred in most instances, especially when breaking loose and applying the final tightness to a fastener.

The combination wrench has a box-end on one end, and an open-end on the other. This combination makes it a very convenient tool.

Adjustable Wrenches

An adjustable wrench, or Crescent wrench (**Figure 12**), can fit nearly any nut or bolt head that has clear access around its entire perimeter. Adjustable wrenches are best used as a backup wrench to keep a large nut or bolt from turning while the other end is being loosened or tightened with a box-end or socket wrench.

Adjustable wrenches contact the fastener at only two points, which makes them more subject to slipping off the fastener. The fact that one jaw is adjustable and may loosen only aggravates this shortcoming. Make certain the solid jaw is the one transmitting the force.

Socket Wrenches, Ratchets and Handles

WARNING

Do not use hand sockets with air or impact tools, as they may shatter and cause injury. Always wear eye protection when using impact or air tools.

Sockets that attach to a ratchet handle are available with 6-point (A, **Figure 13**) or 12-point (B) openings and different drive sizes (**Figure 14**). The drive size indicates the size of the square hole that accepts the ratchet handle. The number stamped on the socket is the size of the work area and must match the fastener head.

As with wrenches, a 6-point socket provides superior-holding ability, while a 12-point socket needs to be moved only half as far to reposition it on the fastener.

Sockets are designated for either hand or impact use. Impact sockets are made of thicker material for more durability. Compare the size and wall thickness of a 19-mm hand socket (A, **Figure 15**) and the 19-mm impact socket (B). Use impact sockets when using an impact driver or air tools. Use hand sockets with hand-driven attachments.

Various handles are available for sockets. The speed handle is used for fast operation. Flexible ratchet heads in varying lengths allow the socket to be turned with varying force, and at odd angles. Extension bars allow the socket setup to reach difficult areas. The ratchet is the most versatile. It allows the user to install or remove the nut without removing the socket.

Sockets combined with any number of drivers make them undoubtedly the fastest, safest and most convenient tool for fastener removal and installation.

Impact Driver

WARNING

Do not use hand sockets with air or impact tools as they may shatter and cause injury. Always wear eye protection when using impact or air tools.

An impact driver provides extra force for removing fasteners, by converting the impact of a hammer into a turning motion. This makes it possible to remove stubborn fasteners without damaging them. Impact drivers and interchangeable bits (**Figure 16**) are available from most tool suppliers. When using a socket with an impact driver make sure the socket is designed for impact use. Refer to *Socket Wrenches, Ratchets and Handles* in this section.

Allen Wrenches

Allen wrenches (**Figure 17**) are used on fasteners with hexagonal recesses in the fastener head. These wrenches are available in L-shaped bar, socket and T-handle types. Allen bolts are sometimes called socket bolts or setscrews.

Torque Wrenches

A torque wrench (**Figure 18**) is used with a socket, torque adapter or similar extension to tighten a fastener to a measured torque. Torque wrenches come in several drive sizes (1/4, 3/8, 1/2 and 3/4) and have various meth-

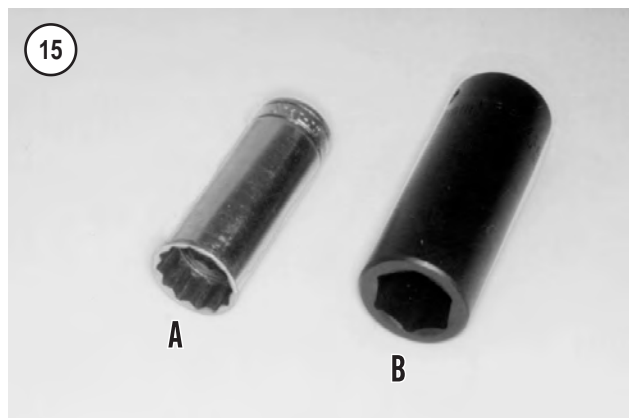
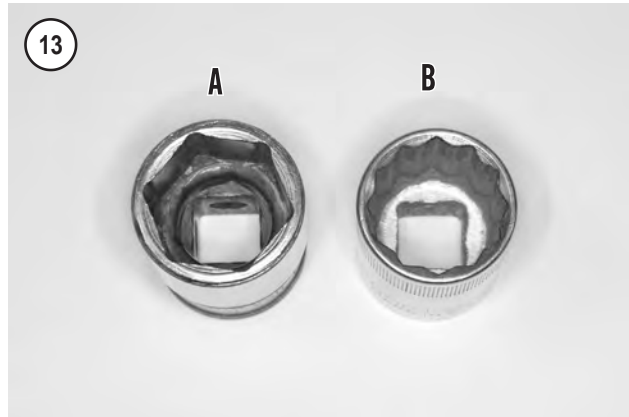

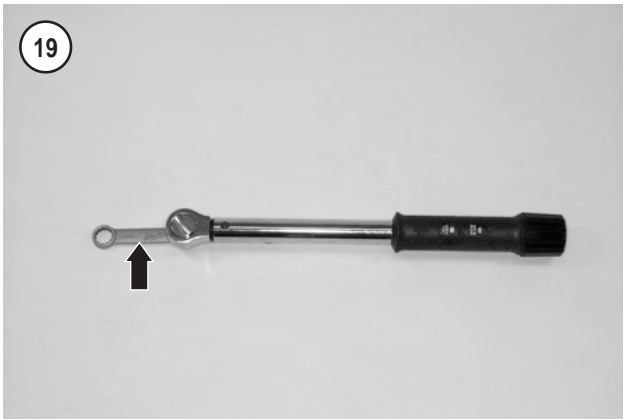

ods for reading the torque value. The drive size indicates the size of the square drive that accepts the socket, adapter or extension. Common methods for reading the torque value are the reflecting beam, the dial indicator and the audible click.

When choosing a torque wrench, consider the torque range, drive size and accuracy. The torque specifications in this manual provide an indication of the range required.

A torque wrench is a precision tool that must be properly cared for to remain accurate. Store torque wrenches in cases or separate padded drawers within a toolbox. Follow the manufacturer’s instructions for their care and calibration.

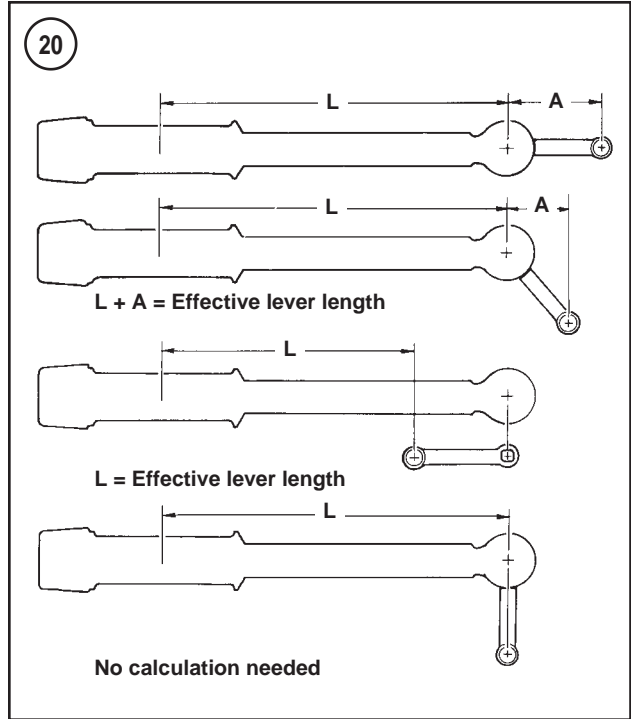

Torque Adapters

Torque adapters or extensions extend or reduce the reach of a torque wrench. The torque adapter shown in **Figure 19** is used to tighten a fastener that cannot be reached due to the size of the torque wrench head, drive, and socket. If a torque adapter changes the effective lever length (**Figure 20**), the torque reading on the wrench will not equal the actual torque applied to the fastener. It is necessary to recalibrate the torque setting on the wrench to compensate for the change of lever length. When a torque adapter is used at a right angle to the drive head, calibration is not required, since the effective length has not changed.

To recalculate a torque reading when using a torque adapter, use the following formula, and refer to **Figure 20**.

$$TW = \frac{TA \times L}{L + A}$$

TW is the torque setting or dial reading on the wrench.

TA is the torque specification and the actual amount of torque that will be applied to the fastener.

A is the amount that the adapter increases (or in some cases reduces) the effective lever length as measured along the centerline of the torque wrench.

L is the lever length of the wrench as measured from the center of the drive to the center of the grip.

The effective length is the sum of L and A.

Example:

TA = 20 ft.-lb.

A = 3 in.

L = 14 in.

$$TW = \frac{20 \times 14}{14 + 3} = \frac{280}{17} = 16.5 \text{ ft.-lb.}$$

In this example, the torque wrench would be set to the recalculated torque value (TW = 16.5 ft.-lb.) . When using a beam-type wrench, tighten the fastener until the pointer aligns with 16.5 ft.-lb. In this example, although the torque wrench is preset to 16.5 ft.-lb., the actual torque is 20 ft.-lb.

Pliers

Pliers come in a wide range of types and sizes. Pliers are useful for holding, cutting, bending, and crimping. Do not use them to turn fasteners. **Figure 21** and **Figure 22** show several types of pliers. Each design has a specialized function. Slip-joint pliers are general-purpose pliers used for gripping and bending. Diagonal cutting pliers are needed to cut wire and can be used to remove cotter pins. Needlenose pliers are used to hold or bend small objects. Locking pliers (**Figure 22**), sometimes called Vise-grips, are used to hold objects very tightly. They have many uses ranging from holding two parts together, to gripping the end of a broken stud. Use caution when using locking pliers, as the sharp jaws will damage the objects they hold.

Snap Ring Pliers

WARNING

Snap rings can slip and fly off when removing and installing them. Also, the snap ring pliers tips may break. Always wear eye protection when using snap ring pliers.

Snap ring pliers are specialized pliers with tips that fit into the ends of snap rings to remove and install them.

Snap ring pliers are available with a fixed action (either internal or external) or convertible (one tool works on both internal and external snap rings). They may have fixed tips or interchangeable ones of various sizes and angles. For general use, select a convertible type of pliers with interchangeable tips.

Hammers

Various types of hammers (**Figure 23**) are available to fit a number of applications. A ball-peen hammer is used to strike another tool, such as a punch or chisel. Soft-faced hammers are required when a metal object must be struck without damaging it. *Never* use a metal-faced hammer on engine and suspension components, as damage will occur.

Always wear eye protection when using hammers. Make sure the hammer face is in good condition and the handle is not cracked. Select the correct hammer for the job and make sure to strike the object squarely. Do not use the handle or the side of the hammer to strike an object.



MEASURING TOOLS

The ability to accurately measure components is essential to successfully complete many procedures in this manual. Equipment is manufactured to close tolerances, and obtaining consistently accurate measurements is essential to determining which components require replacement or further service.

Each type of measuring instrument is designed to measure a dimension with a certain degree of accuracy and within a certain range. When selecting the measuring tool, make sure it is applicable to the task. Refer to **Figure 24** for a comprehensive measuring set.

As with all tools, measuring tools provide the best results if cared for properly. Improper use can damage the tool and

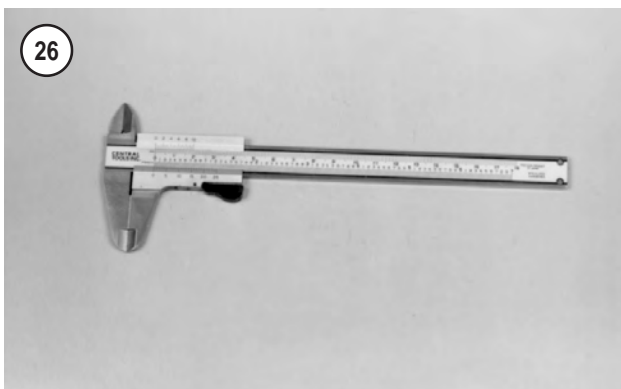

result in inaccurate results. If any measurement is questionable, verify the measurement using another tool. A standard gauge is usually provided with measuring tools to check accuracy and calibrate the tool if necessary.

Precision measurements can vary according to the experience of the person performing the procedure. Accurate results are only possible if the mechanic possesses a feel for using the tool. Heavy-handed use of measuring tools will produce less accurate results. Hold the tool gently by the fingertips so the point at which the tool contacts the object is easily felt. This feel for the equipment will produce more accurate measurements and reduce the risk of damaging the tool or component. Refer to the following sections for specific measuring tools.

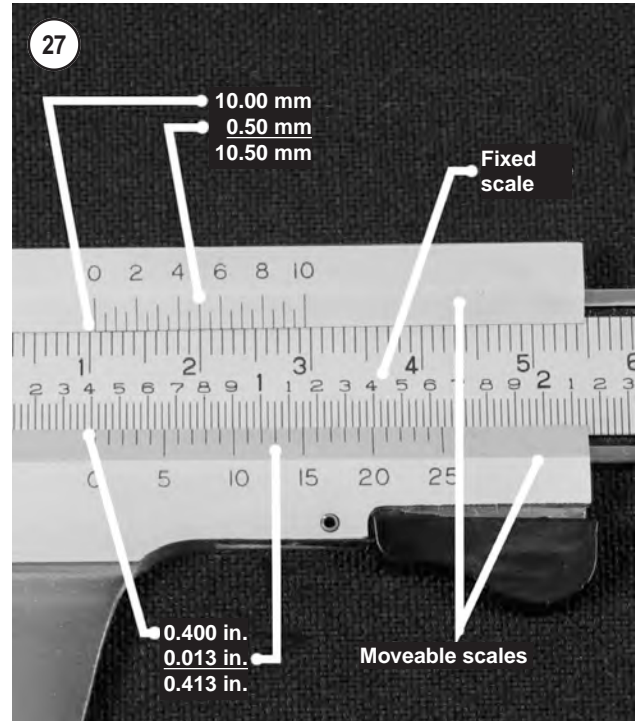

Feeler Gauge

The feeler or thickness gauge (**Figure 25**) is used for measuring the distance between two surfaces.

A feeler gauge set consists of an assortment of steel strips of graduated thickness. Each blade is marked with its thickness. Blades can be of various lengths and angles for different procedures.

A common use for a feeler gauge is to measure valve clearance. Wire (round) type gauges are used to measure spark plug gap.

Calipers

Calipers (**Figure 26**) are excellent tools for obtaining inside, outside and depth measurements. Although not as precise as a micrometer, they allow reasonable precision, typically to within 0.001 in. (0.05 mm). Most calipers have a range up to 6 in. (150 mm).

Calipers are available in dial, vernier or digital versions. Dial calipers have a dial readout that provides convenient reading. Vernier calipers have marked scales that must be compared to determine the measurement. The digital caliper uses a LCD to show the measurement.

Properly maintain the measuring surfaces of the caliper. There must not be any dirt or burrs between the tool and the object being measured. Never force the caliper closed around an object; close the caliper around the highest point so it can be removed with a slight drag. Some calipers require calibration. Always refer to the manufacturer's instructions when using a new or unfamiliar caliper.

To read a vernier caliper refer to **Figure 27**. The fixed scale is marked in 0.001 in. increments. Forty individual

28

DECIMAL PLACE VALUES*

| | |
|-------|--|
| 0.1 | Indicates 1/10 (one tenth of an inch or millimeter) |
| 0.010 | Indicates 1/100 (one one-hundredth of an inch or millimeter) |
| 0.001 | Indicates 1/1000 (one one-thousandth of an inch or millimeter) |

*This chart represents the values of figures placed to the right of the decimal point. Use it when reading decimals from one-tenth to one one-thousandth of an inch or millimeter. It is not a conversion chart (for example: 0.001 in. is not equal to 0.001 mm).

lines on the fixed scale equal 1 in. The moveable scale is marked in 0.01 mm (hundredth) increments. To obtain a reading, establish the first number by the location of the 0 line on the movable scale in relation to the first line to the left on the fixed scale. In this example, the number is 0.400 in. To determine the next number, note which of the lines on the movable scale align with a mark on the fixed scale. A number of lines will seem close, but only one will align exactly. In this case, 0.013 in. is the reading to add to the first number. The result of adding 0.400 in. and 0.013 in. is a measurement of 0.413 in.

Micrometers

A micrometer is an instrument designed for linear measurement using the decimal divisions of the inch or meter (Figure 28). While there are many types and styles of micrometers, most of the procedures in this manual call for an outside micrometer. The outside micrometer is used to measure the outside diameter of cylindrical forms and the thickness of materials.

A micrometer's size indicates the minimum and maximum size of a part that it can measure. The usual sizes (Figure 29) are 0-1 in. (0-25 mm), 1-2 in. (25-50 mm), 2-3 in. (50-75 mm) and 3-4 in. (75-100 mm).

Micrometers that cover a wider range of measurements are available. These use a large frame with interchangeable anvils of various lengths. This type of micrometer offers a cost savings; however, its overall size may make it less convenient.

Adjustment

Before using a micrometer, check its adjustment as follows.

1. Clean the anvil and spindle faces.
- 2A. To check a 0-1 in. (0-25 mm) micrometer:
 - a. Turn the thimble until the spindle contacts the anvil. If the micrometer has a ratchet stop, use it to ensure that the proper amount of pressure is applied.
 - b. If the adjustment is correct, the 0 mark on the thimble will align exactly with the 0 mark on the sleeve line.

29

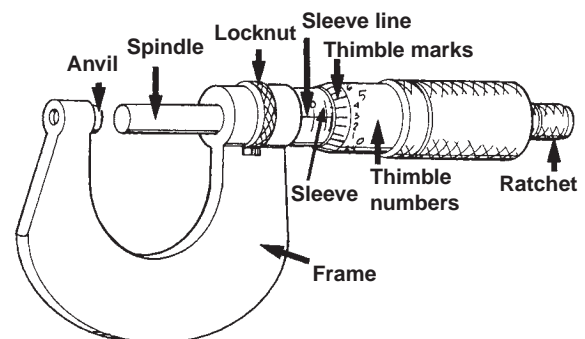

30

STANDARD INCH MICROMETER

If the marks do not align, the micrometer is out of adjustment.

- c. Follow the manufacturer's instructions to adjust the micrometer.
- 2B. To check a micrometer larger than 1 in. (25 mm) use the standard gauge supplied by the manufacturer. A standard gauge is a steel block, disc or rod that is machined to an exact size.
 - a. Place the standard gauge between the spindle and anvil, and measure its outside diameter or length. If the

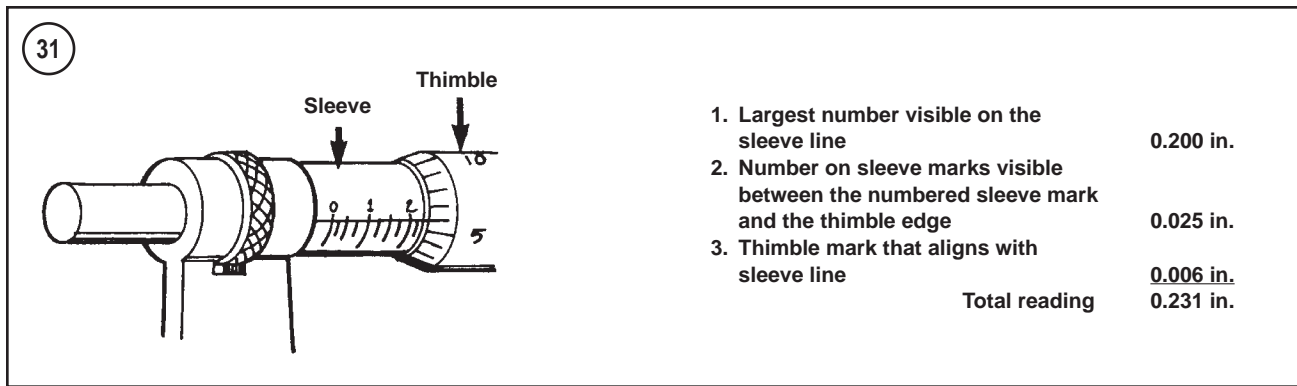

micrometer has a ratchet stop, use it to ensure that the proper amount of pressure is applied.

- b. If the adjustment is correct, the 0 mark on the thimble will align exactly with the 0 mark on the sleeve line. If the marks do not align, the micrometer is out of adjustment.
- c. Follow the manufacturer's instructions to adjust the micrometer.

Care

Micrometers are precision instruments. They must be used and maintained with great care. Note the following:

1. Store micrometers in protective cases or separate padded drawers in a toolbox.
2. When in storage, make sure the spindle and anvil faces do not contact each other or another object. If they do, temperature changes and corrosion may damage the contact faces.
3. Do not clean a micrometer with compressed air. Dirt forced into the tool will cause wear.
4. Lubricate micrometers to prevent corrosion.

Reading

When reading a micrometer, numbers are taken from different scales and added together.

For accurate results, properly maintain the measuring surfaces of the micrometer. There can not be any dirt or burrs between the tool and the measured object. Never force the micrometer closed around an object. Close the micrometer around the highest point so it can be removed with a slight drag. **Figure 30** shows the markings and parts of a standard inch micrometer. Be familiar with these terms before using a micrometer in the follow sections.

Standard inch micrometer

The standard inch micrometer is accurate to one-thousandth of an inch or 0.001. The sleeve is marked in 0.025 in. increments. Every fourth sleeve mark is numbered 1, 2, 3,

4, 5, 6, 7, 8, 9. These numbers indicate 0.100, 0.200, 0.300, and so on.

The tapered end of the thimble has twenty-five lines marked around it. Each mark equals 0.001 in. One complete turn of the thimble will align its zero mark with the first mark on the sleeve or 0.025 in.

When reading a standard inch micrometer, perform the following steps while referring to **Figure 31**.

1. Read the sleeve and find the largest number visible. Each sleeve number equals 0.100 in.
2. Count the number of lines between the numbered sleeve mark and the edge of the thimble. Each sleeve mark equals 0.025 in.
3. Read the thimble mark that aligns with the sleeve line. Each thimble mark equals 0.001 in. If a thimble mark does not align exactly with the sleeve line, estimate the amount between the lines. For accurate readings in ten-thousandths of an inch (0.0001 in.), use a vernier inch micrometer.
4. Add the readings from Steps 1-3.

Vernier inch micrometer

A vernier inch micrometer is accurate to one ten-thousandth of an inch or 0.0001 in. It has the same marking as a standard inch micrometer with an additional vernier scale on the sleeve. The vernier scale consists of 11 lines marked 1-9 with a 0 on each end. These lines run parallel to the thimble lines and represent 0.0001 in. increments.

When reading a vernier inch micrometer, perform the following steps while referring to **Figure 32**.

1. Read the micrometer in the same way as a standard micrometer. This is the initial reading.
2. If a thimble mark aligns exactly with the sleeve line, reading the vernier scale is not necessary. If they do not align, read the vernier scale in Step 3.
3. Determine which vernier scale mark aligns with one thimble mark. The vernier scale number is the amount in ten-thousandths of an inch to add to the initial reading from Step 1.

32

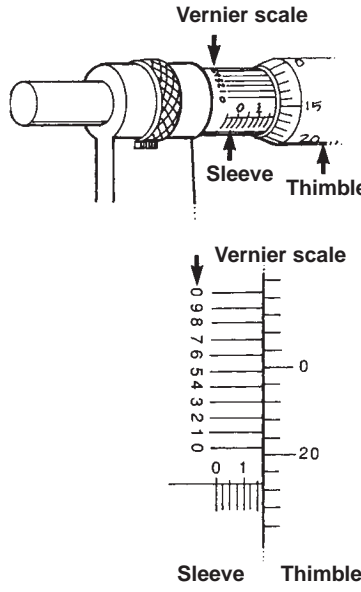

The diagram shows a micrometer with a sleeve and a thimble. The sleeve has markings for 0, 15, and 20. The thimble has markings from 0 to 20. A Vernier scale is also shown below, with markings from 0 to 20 on the sleeve and 0 to 20 on the thimble.

1. Largest number visible on sleeve line 0.100 in.
2. Number of sleeve marks visible between the number sleeve mark and the thimble edge 0.050 in.
3. Thimble is between 0.018 and 0.019 in. on the sleeve line 0.018 in.
4. Vernier line coinciding with thimble line 0.0003 in.

Total reading **0.1683 in.**

Telescoping and Small Bore Gauges

Use telescoping gauges (**Figure 33**) and small hole gauges (**Figure 34**) to measure bores. Neither gauge has a scale for direct readings. An outside micrometer must be used to determine the reading.

To use a telescoping gauge, select the correct size gauge for the bore. Compress the movable post and insert the gauge into the bore. Move the gauge in the bore to make sure it is centered. Tighten the knurled end of the gauge to hold the movable post in position. Remove the gauge and measure the length of the posts. Telescoping gauges are typically used to measure cylinder bores.

To use a small-bore gauge, select the correct size gauge for the bore. Insert the gauge into the bore. Tighten the knurled end of the gauge to carefully expand the gauge fingers to the limit within the bore. Do not overtighten the gauge, as there is no built-in release. Excessive tightening can damage the bore surface and damage the tool. Remove the gauge and measure the outside dimension (**Figure 35**). Small hole gauges are typically used to measure valve guides.

Dial Indicator

A dial indicator (**Figure 36**) is a gauge with a dial face and needle used to measure variations in dimensions and movements. Measuring brake rotor runout is a typical use for a dial indicator.

Dial indicators are available in various ranges and graduations and with three basic types of mounting bases: magnetic, clamp, or screw-in stud.



Cylinder Bore Gauge

A cylinder bore gauge is similar to a dial indicator. The gauge set shown in **Figure 37** consists of a dial indicator, handle, and different length adapters (anvils) to fit the gauge to various bore sizes. The bore gauge is used to mea-

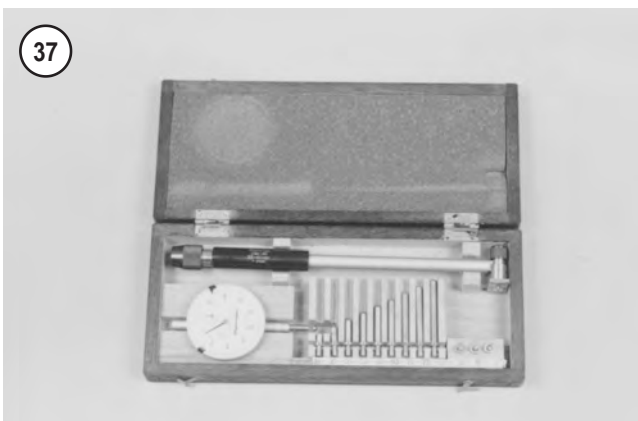

sure bore size, taper and out-of-round. When using a bore gauge, follow the manufacturer's instructions.

Compression Gauge

A compression gauge (**Figure 38**) measures combustion chamber (cylinder) pressure, usually in psi or kg/cm². The gauge adapter is either inserted or screwed into the spark plug hole to obtain the reading. Disable the engine so it will not start and hold the throttle in the wide-open position when performing a compression test. An engine that does not have adequate compression cannot be properly tuned. Refer to Chapter Three.

Multimeter

A multimeter (**Figure 39**) is an essential tool for electrical system diagnosis. The voltage function indicates the voltage applied or available to various electrical components. The ohmmeter function tests circuits for continuity, or lack of continuity, and measures the resistance of a circuit.

Some manufacturers' specifications for electrical components are based on results using a specific test meter. Results may vary if a meter not recommended by the manufacturer is used. Such requirements are noted when applicable.

Each time an analog ohmmeter is used or if the scale is changed, the ohmmeter must be calibrated.

Digital ohmmeters do not require calibration.

ELECTRICAL SYSTEM FUNDAMENTALS

A thorough study of the many types of electrical systems used in today's motorcycles is beyond the scope of this manual. However, a basic understanding of electrical basics is necessary to perform diagnostic tests.

Voltage

Voltage is the electrical potential or pressure in an electrical circuit and is expressed in volts. The more pressure (voltage) in a circuit, the more work that can be performed.

Direct current (DC) voltage means the electricity flows in one direction. All circuits powered by a battery are DC circuits.

Alternating current (AC) means that the electricity flows in one direction momentarily then switches to the opposite direction. Alternator output is an example of AC voltage. This voltage must be changed or rectified to direct current to operate in a battery powered system.

Resistance

Resistance is the opposition to the flow of electricity within a circuit or component and is measured in ohms. Resistance causes a reduction in available current and voltage.

Resistance is measured in an inactive circuit with an ohmmeter. The ohmmeter sends a small amount of current into the circuit and measures how difficult it is to push the current through the circuit.

An ohmmeter, although useful, is not always a good indicator of a circuit's actual ability under operating conditions. This is due to the low voltage (6-9 volts) that the meter uses to test the circuit. The voltage in an ignition coil secondary winding can be several thousand volts. Such high voltage can cause the coil to malfunction, even though it tests acceptable during a resistance test.

Resistance generally increases with temperature. Perform all testing with the component or circuit at room temperature. Resistance tests performed at high temperatures may indicate high resistance readings and result in the unnecessary replacement of a component.

Amperage

Amperage is the unit of measure for the amount of current within a circuit. Current is the actual flow of electricity. The higher the current, the more work that can be performed up to a given point. If the current flow exceeds the circuit or component capacity, the system will be damaged.

SERVICE METHODS

Most of the procedures in this manual are straightforward and can be performed by anyone reasonably competent with tools. However, consider personal capabilities carefully before attempting any operation involving major disassembly.

1. Front, in this manual, refers to the front of the motorcycle. The front of any component is the end closest to the front of the motorcycle. The left and right sides refer to the position of the parts as viewed by the rider sitting on the seat facing forward.



2. Whenever servicing an engine or suspension component, secure the motorcycle in a safe manner.

3. Tag all similar parts for location and mark all mating parts for position. Record the number and thickness of any shims as they are removed. Identify parts by placing them in sealed and labeled plastic sandwich bags.

4. Tag disconnected wires and connectors with masking tape and a marking pen. Do not rely on memory alone.

5. Protect finished surfaces from physical damage or corrosion. Keep gasoline and other chemicals off painted surfaces.

6. Use penetrating oil on frozen or tight bolts. Avoid using heat where possible. Heat can warp, melt or affect the temper of parts. Heat also damages the finish of paint and plastics.

7. When a part is a press fit or requires a special tool for removal, the information or type of tool is identified in the text. Otherwise, if a part is difficult to remove or install, determine the cause before proceeding.

8. To prevent objects or debris from falling into the engine, cover all openings.

9. Read each procedure thoroughly and compare the illustrations to the actual components before starting the procedure. Perform the procedure in sequence.

10. Recommendations are occasionally made to refer service to a dealership or specialist. In these cases, the work can be performed more economically by the specialist, than by the home mechanic.

11. The term *replace* means to discard a defective part and replace it with a new part. *Overhaul* means to remove, disassemble, inspect, measure, repair and/or replace parts as required to recondition an assembly.

12. Some operations require the use of a hydraulic press. If a press is not available, have these operations performed by a shop equipped with the necessary equipment. Do not use makeshift equipment that may damage the motorcycle.

13. Repairs are much faster and easier if the motorcycle is clean before starting work. Degrease the motorcycle with a commercial degreaser; follow the directions on the container for the best results. Clean all parts with cleaning solvent as they are removed.

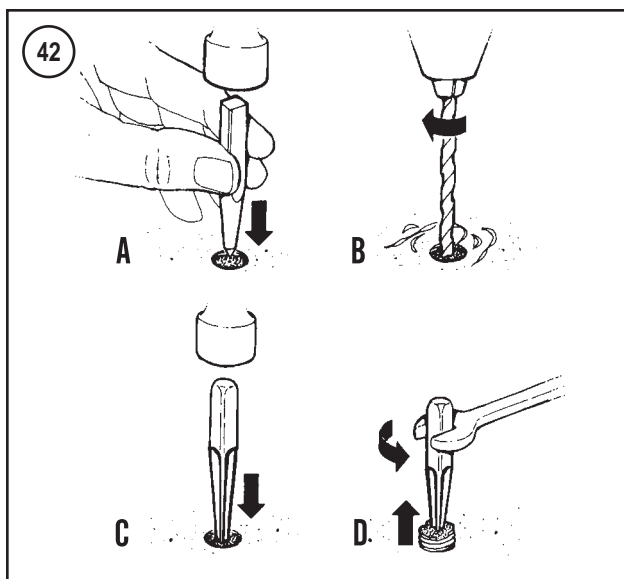
**CAUTION**

Do not direct high-pressure water at steering bearings, carburetor hoses, wheel bearings, suspension and electrical components. The water will force the grease out of the bearings and possibly damage the seals.

14. If special tools are required, have them available before starting the procedure. When special tools are required, they will be described at the beginning of the procedure.
15. Make diagrams of similar-appearing parts. For instance, crankcase bolts are often not the same lengths. Do not rely on memory alone. It is possible that carefully laid out parts will become disturbed, making it difficult to reassemble the components correctly without a diagram.
16. Make sure all shims and washers are reinstalled in the same location and position.
17. Whenever rotating parts contact a stationary part, look for a shim or washer.
18. Use new gaskets if there is any doubt about the condition of old ones.

19. If self-locking fasteners are removed, replace them with new ones. Do not install standard fasteners in place of self-locking ones.

20. Use grease to hold small parts in place if they tend to fall out during assembly. Do not apply grease to electrical or brake components.

Ignition Grounding

Modern motorcycle ignition systems produce sufficient voltage to damage ignition components if the secondary voltage is not grounded during operation. During normal operation, grounding of the secondary circuit occurs at the spark plug. When performing some tests, such as compression testing, it may be necessary to disconnect the spark plug cap from the spark plug. It is a good practice to ground a disconnected spark plug cap to the engine if the ignition is on, and may be required by some manufacturers to protect the ignition system.

A grounding device may be fabricated to route secondary circuit voltage to the engine. **Figure 40** shows a tool that is useful when grounding a single spark plug cap, and **Figure 41** shows a grounding strap that allows the grounding of several spark plug caps. Both tools use a stud or bolt that fits the spark plug connector in the spark plug cap. An alligator clip permits electrical connection to suitable points on the engine.

Removing Frozen Fasteners

If a fastener cannot be removed, several methods may be used to loosen it. First, apply penetrating oil liberally and let it soak for 10-15 minutes. Rap the fastener several times with a small hammer. Do not hit it hard enough to cause damage. Reapply the penetrating oil if necessary.

For frozen screws, apply penetrating oil as described, then insert a screwdriver in the slot and rap the top of the screwdriver with a hammer. This loosens the rust so the screw can be removed in the normal way. If the screw head is too damaged to use this method, grip the head with locking pliers and twist the screw out.

Avoid applying heat unless specifically instructed, as it may melt, warp or remove the temper from parts.

Removing Broken Fasteners

If the head breaks off a screw or bolt, several methods are available for removing the remaining portion. If a large portion of the remainder projects out, try gripping it with locking pliers. If the projecting portion is too small, file it to fit a wrench or cut a slot in it to fit a screwdriver.

If the head breaks off flush, use a screw extractor. To do this, centerpunch the exact center of the remaining portion of the screw or bolt (A, **Figure 42**). Drill a small hole in the screw (B, **Figure 42**) and tap the extractor into the hole (C).

Back the screw out with a wrench on the extractor (D, **Figure 42**).

Repairing Damaged Threads

Occasionally, threads are stripped through carelessness or impact damage. Often the threads can be repaired by running a tap (for internal threads on nuts) or die (for external threads on bolts) through the threads (**Figure 43**). To clean or repair spark plug threads, use a spark plug tap.

If an internal thread is damaged, it may be necessary to install a Helicoil or some other type of thread insert. Follow the manufacturer's instructions when installing their insert.

If it is necessary to drill and tap a hole, refer to **Table 9** or **Table 10** for appropriate tap and drill sizes.

Stud Removal/Installation

A stud removal tool (**Figure 44**) makes the removal and installation of studs easier. If one is not available, thread two nuts onto the stud and tighten them against each other. Remove the stud by turning the lower nut.

1. Measure the height of the stud above the surface.
2. Thread the stud removal tool onto the stud and tighten it.
3. Remove the stud by turning the stud remover.
4. Remove any threadlocking compound from the threaded hole. Clean the threads with an aerosol parts cleaner.
5. Install the stud removal tool onto the new stud.
6. Apply threadlocking compound to the threads of the stud.
7. Install the stud and tighten.
8. Install the stud to the height noted in Step 1 or to its torque specification.
9. Remove the stud removal tool or the two nuts.

Removing Hoses

When removing stubborn hoses, do not exert excessive force on the hose or fitting. Remove the hose clamp and carefully insert a small screwdriver or pick tool between the fitting and hose. Apply a spray lubricant under the hose and carefully twist the hose off the fitting. Clean the fitting of any corrosion or rubber hose material with a wire brush. Clean the inside of the hose thoroughly. Do not use any lubricant when installing the hose (new or old). The lubricant may allow the hose to come off the fitting, even with the clamp secure.

Bearings

Bearings are used in the engine and transmission assembly to reduce power loss, heat and noise resulting from friction. Because bearings are precision parts, they must be maintained with proper lubrication and maintenance. If a

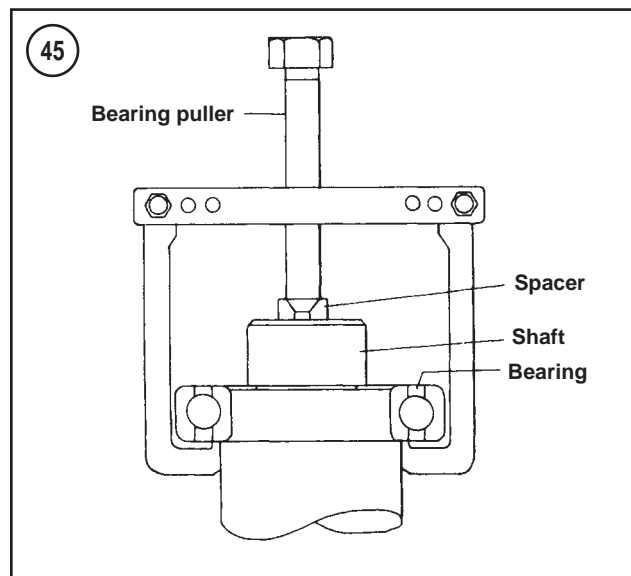
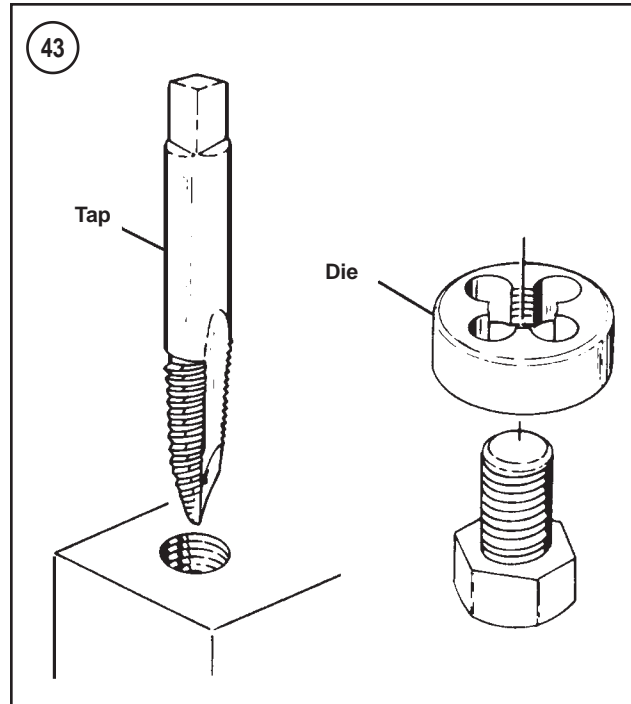

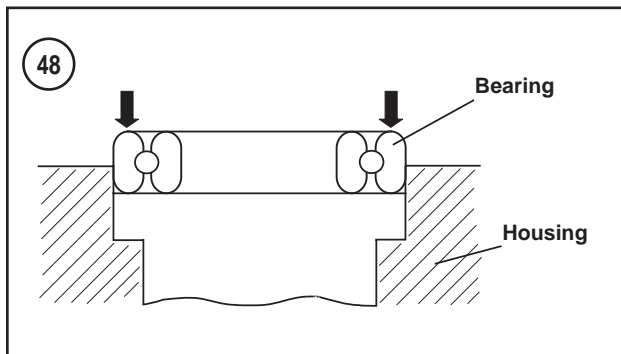
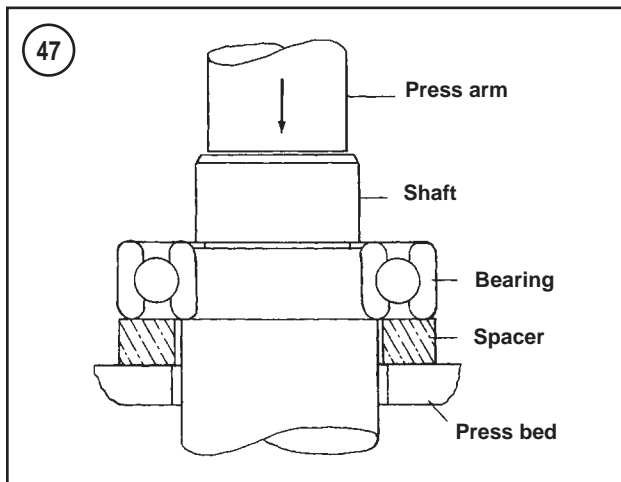
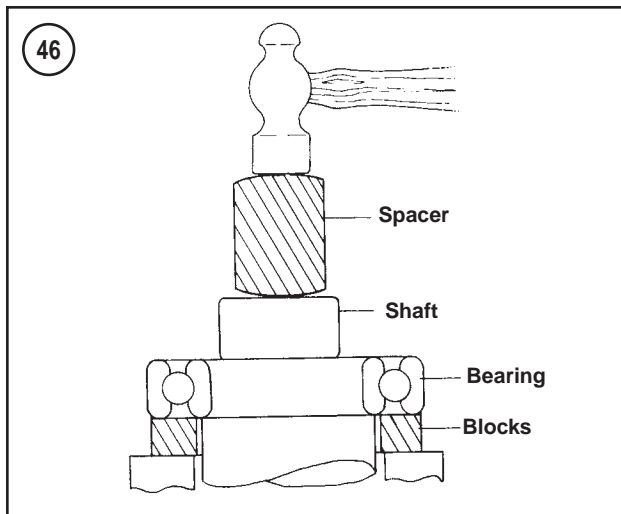

bearing is damaged, replace it immediately. When installing a new bearing, take care to prevent damaging it. Bearing replacement procedures are included in the individual chapters where applicable; however, use the following sections as a guideline.

NOTE

Unless otherwise specified, install bearings with the manufacturer's mark or number facing out.

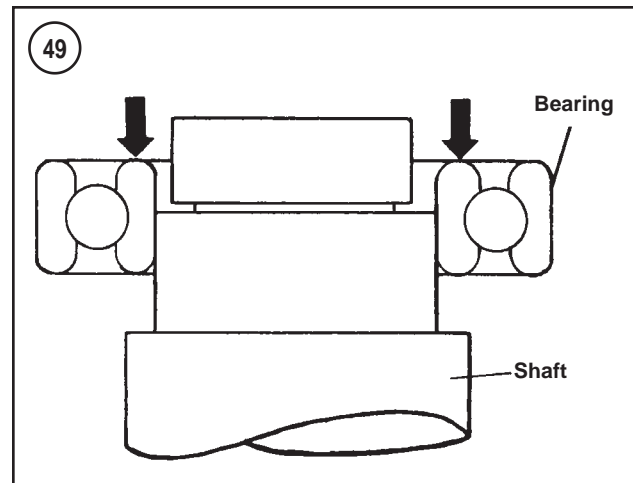

Removal

While bearings are normally removed only when damaged, there may be times when it is necessary to remove a bearing that is in good condition. However, improper bearing removal will damage the bearing and maybe the shaft or case half. Note the following when removing bearings.

1. When using a puller to remove a bearing from a shaft, take care that the shaft is not damaged. Always place a piece of metal between the end of the shaft and the puller screw. In addition, place the puller arms next to the inner bearing race (**Figure 45**).
2. When using a hammer to remove a bearing from a shaft, do not strike the hammer directly against the shaft. Instead, use a brass or aluminum spacer between the hammer and shaft (**Figure 46**) and make sure to support both bearing races with wooden blocks as shown.
3. The ideal method of bearing removal is with a hydraulic press. Note the following when using a press:
 - a. Always support the inner and outer bearing races with a suitable size wooden or aluminum spacer (**Figure 47**). If only the outer race is supported, pressure applied against the balls and/or the inner race will damage them.
 - b. Always make sure the press arm (**Figure 47**) aligns with the center of the shaft. If the arm is not centered, it may damage the bearing and/or shaft.
 - c. The moment the shaft is free of the bearing, it will drop to the floor. Secure or hold the shaft to prevent it from falling.

Installation

1. When installing a bearing in a housing, apply pressure to the *outer* bearing race (**Figure 48**). When installing a bearing on a shaft, apply pressure to the *inner* bearing race (**Figure 49**).
2. When installing a bearing as described in Step 1, some type of driver is required. Never strike the bearing directly with a hammer or the bearing will be damaged. When in-

stalling a bearing, use a piece of pipe or a driver (Figure 50) with a diameter that matches the bearing inner race.

3. Step 1 describes how to install a bearing in a case half or over a shaft. However, when installing a bearing over a shaft and into the housing at the same time, a tight fit will be required for both outer and inner bearing races. In this situation, install a spacer underneath the driver tool so that pressure is applied evenly across both races (Figure 51). If the outer race is not supported as shown, the balls will push against the outer bearing race and damage it.

Interference fit

1. Follow this procedure when installing a bearing over a shaft. When a tight fit is required, the bearing inside diameter will be smaller than the shaft. In this case, driving the bearing on the shaft using normal methods may cause bearing damage. Instead, heat the bearing before installation. Note the following:

- a. Secure the shaft so it is ready for bearing installation.
- b. Clean all residues from the bearing surface of the shaft. Remove burrs with a file or sandpaper.
- c. Fill a suitable pot or beaker with clean mineral oil. Place a thermometer rated above 248° F (120° C) in the oil. Support the thermometer so that it does not rest on the bottom or side of the pot.
- d. Remove the bearing from its wrapper and secure it with a piece of heavy wire bent to hold it in the pot. Hang the bearing in the pot so it does not touch the bottom or sides of the pot.
- e. Turn the heat on and monitor the thermometer. When the oil temperature rises to approximately 248° F (120° C), remove the bearing from the pot and quickly install it. If necessary, place a socket on the inner bearing race and tap the bearing into place. As the bearing chills, it will tighten on the shaft, so installation must be done quickly. Make sure the bearing is installed completely.

2. Follow this step when installing a bearing in a housing. Bearings are generally installed in a housing with a slight interference fit. Driving the bearing into the housing using normal methods may damage the housing or cause bearing damage. Instead, heat the housing before the bearing is installed. Note the following:

CAUTION

Before heating the housing in this procedure, wash the housing thoroughly with detergent and water. Rinse and rewash the cases as required to remove all traces of oil and other chemical deposits.

- a. Heat the housing to approximately 212° F (100° C) in an oven or on a hot plate. An easy way to check that it is the proper temperature is to place tiny drops of water on the housing; if they sizzle and evaporate immediately,

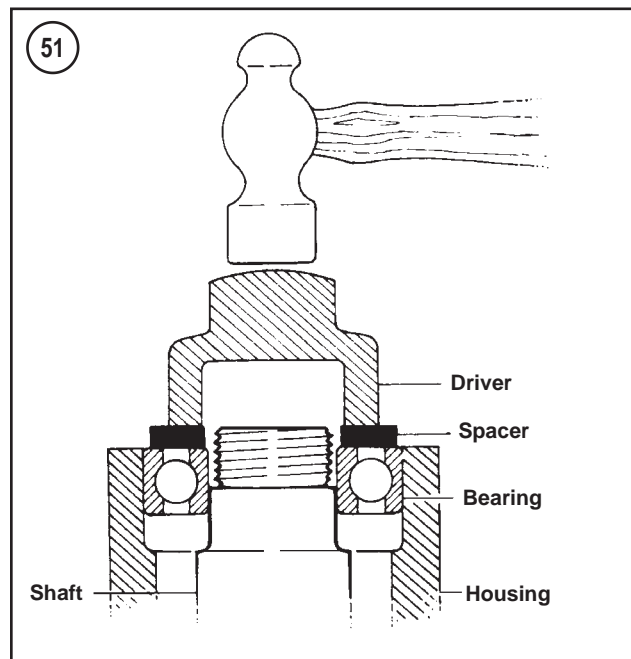
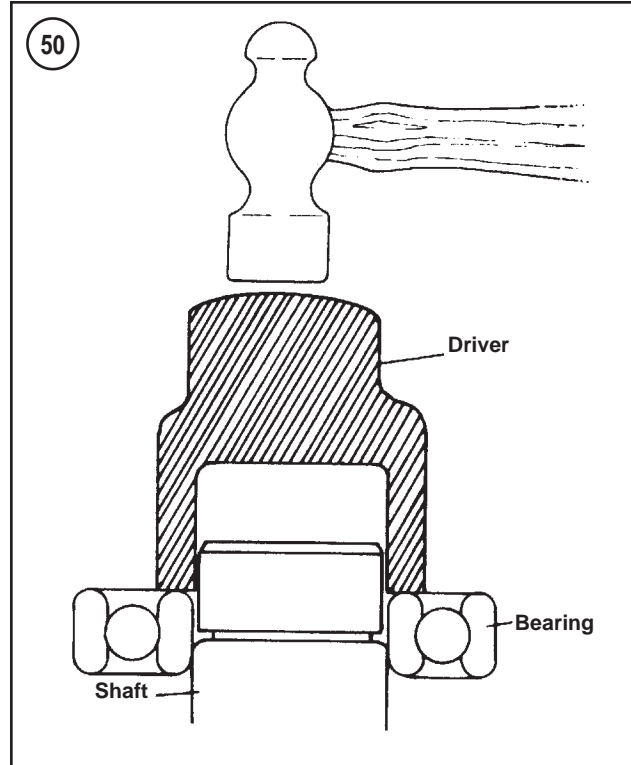

diately, the temperature is correct. Heat only one housing at a time.

CAUTION

Do not heat the housing with a propane or acetylene torch. Never bring a flame into contact with the bearing or housing. The direct heat will destroy the case hardening of the bearing and will likely warp the housing.

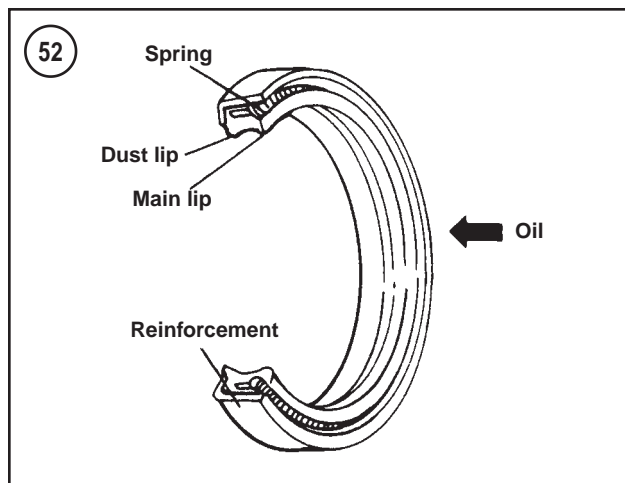

- b. Remove the housing from the oven or hot plate, and hold onto the housing with protective gloves

NOTE

Remove and install the bearings with a suitable size socket and extension.

- c. Hold the housing with the bearing side down and tap the bearing out. Repeat for all bearings in the housing.

- d. Before heating the bearing housing, place the new bearing in a freezer if possible. Chilling a bearing slightly reduces its outside diameter while the heated bearing housing assembly is slightly larger due to heat expansion. This will make bearing installation easier.

NOTE

Always install bearings with the manufacturer's mark or number facing outward.

- e. While the housing is still hot, install the new bearing(s) into the housing. Install the bearings by hand, if possible. If necessary, lightly tap the bearing(s) into the housing with a socket placed on the outer bearing race (**Figure 48**). Do not install new bearings by driving on the inner-bearing race. Install the bearing(s) until it seats completely.

Seal Replacement

Seals (**Figure 52**) are used to contain oil, water, grease or combustion gasses in a housing or shaft. Improper removal of a seal can damage the housing or shaft. Improper installation of the seal can damage the seal. Note the following:

1. Prying is generally the easiest and most effective method of removing a seal from the housing. However, always place a rag underneath the pry tool (**Figure 53**) to prevent damage to the housing.
2. Pack waterproof grease in the seal lips before the seal is installed.
3. In most cases, install seals with the manufacturer's numbers or marks face out.
4. Install seals with a socket placed on the outside of the seal as shown in **Figure 54**. Drive the seal squarely into the housing until it is flush. Never install a seal by hitting against the top of the seal with a hammer.

STORAGE

Several months of non-use can cause a general deterioration of the motorcycle. This is especially true in areas of extreme temperature variations. This deterioration can be minimized with careful preparation for storage. A properly stored motorcycle will be much easier to return to service.

Location

When selecting a storage area, consider the following:

1. The storage area must be dry. A heated area is best, but not necessary. It should be insulated to minimize extreme temperature variations.
2. If the building has large window areas, mask them to keep sunlight off the motorcycle.
3. Avoid buildings in industrial areas where corrosive emissions may be present. Avoid areas close to saltwater.

4. Consider the area’s risk of fire, theft or vandalism. Check with an insurer regarding motorcycle coverage while in storage.

Preparation

The amount of preparation a motorcycle should undergo before storage depends on the expected length of non-use, storage area conditions and personal preference. Consider the following list the minimum requirement:

1. Wash the motorcycle thoroughly. Make sure all dirt, mud and road debris are removed.
2. Start the engine and allow it to reach operating temperature. Drain the engine oil, and transmission oil, regardless of the riding time since the last service. Fill the engine and transmission with the recommended type of oil.
3. Drain all fuel from the fuel tank. Run the engine until all the fuel is consumed from the lines and carburetor.
4. Drain the fuel from the carburetor as follows:
 - a. Remove the fuel tank as described in Chapter Eight.
 - b. Open the drain screw and thoroughly drain the fuel from the float bowl into a suitable container.
 - c. Move the choke knob to the full open position.
 - d. Operate the start button and try to start the engine. This will draw out all remaining fuel from the jets.
5. Remove the spark plugs and pour a teaspoon of engine oil into the cylinders. Place a rag over the openings and slowly turn the engine over to distribute the oil. Reinstall the spark plugs.

6. Remove the battery. Store the battery in a cool and dry location.
7. Cover the exhaust and intake openings.
8. Reduce the normal tire pressure by 20 percent.
9. Apply a protective substance to the plastic and rubber components, including the tires. Make sure to follow the manufacturer’s instructions for each type of product being used.
10. Place the motorcycle on a stand or wooden blocks, so the wheels are off the ground. If this is not possible, place a piece of plywood between the tires and the ground. Inflate the tires to the recommended pressure if the motorcycle can not be elevated.
11. Cover the motorcycle with old bed sheets or something similar. Do not cover it with any plastic material that will trap moisture.

Returning the Motorcycle to Service

The amount of service required when returning a motorcycle to service after storage depends on the length of non-use and storage conditions. In addition to performing the reverse of the above procedure, make sure the brakes, clutch, throttle and engine stop switch work properly before operating the motorcycle. Refer to Chapter Three and evaluate the service intervals to determine which areas require service.

Table 1 MODEL DESIGNATIONS

| |
|---|
| XLH883 (1986-2003 models) XLH883 CUSTOM (1999-2003 models) XLH883 DELUXE (1986-1995 models) XLH883 HUGGER (1987-2003 models) XL883R (2002-2003 models) XLH1100 (1986-1987 models) XLH1200 (1988-2003 models) XL1200 CUSTOM (1996-2003 models) XL1200 SPORT (1996-2003 models) |
|---|

Table 2 GENERAL DIMENSIONS

| | |
|------------------------------|--------------------|
| XLH883, XLH883 Deluxe | |
| Wheelbase | |
| 1986-2001 models | 60.2 in. (1529 mm) |
| 2002-2003 models | 60.0 in. (1524 mm) |
| Length | |
| 1986-2001 models | 87.6 in. (2225 mm) |
| 2002-2003 models | 88.1 in. (2238 mm) |
| | (continued) |

Table 2 GENERAL DIMENSIONS (continued)

| | |
|--|---------------------|
| XLH883, XLH883 Deluxe (continued) | |
| Width | |
| 1986-1994 models | 32 in. (813 mm) |
| 1995-2003 models | 33 in. (838 mm) |
| Height | |
| 1986-2001 models | 47.5 in. (1207 mm) |
| 2002-2003 models | 49.5 in. (1257 mm) |
| Ground clearance | |
| 1986-1994 models | 6.75 in. (171.5 mm) |
| 1995-2003 models | 6.70 in. (170 mm) |
| XLH883 Custom | |
| Wheelbase | 59.0 in. (1499 mm) |
| Length | |
| 1999-2001 models | 87.25 in. (2216 mm) |
| 2002-2003 models | 89.0 in. (2261 mm) |
| Width | |
| 1999-2001 models | 35 in. (889 mm) |
| Height | |
| 1999-2001 models | 49.75 in. (1264 mm) |
| Ground clearance | |
| 2002-2003 models | 6.70 in. (170 mm) |
| XLH883 Hugger | |
| Wheelbase | |
| 1986-1992 models | 60.5 in. (1537 mm) |
| 1993-2003 models | 59.0 in. (1499 mm) |
| Length | |
| 1986-1991 models | 87.6 in. (2225 mm) |
| 1992-2001 models | 87.25 in. (2216 mm) |
| 2002-2003 models | 88.0 in. (2235 mm) |
| Width | |
| 1986-1994 models | 33 in. (838 mm) |
| 1995-2003 models | 35 in. (889 mm) |
| Height | |
| 1986-1992 models | 49.75 in. (1264 mm) |
| Ground clearance | |
| 1986-1992 models | 5.9 in. (150 mm) |
| 1993-2001 models | 4.5 in. (114 mm) |
| 2002-2003 models | 4.7 in. (119 mm) |
| XL883R | |
| Wheelbase | 60.0 in. (1524 mm) |
| Length | 88.1 in. (2238 mm) |
| Width | 33.0 in. (838 mm) |
| Height | 47.5 in. (1207 mm) |
| Ground clearance | 6.70 in. (170 mm) |
| XLH1100 | |
| Wheelbase | 60.2 in. (1529 mm) |
| Length | 87.6 in. (2225 mm) |
| Width | 33 in. (838 mm) |
| Height | 49.75 in. (1264 mm) |
| Ground clearance | 6.75 in. (171.5 mm) |
| XLH1200 | |
| Wheelbase | 60.2 in. (1529 mm) |
| Length | 87.6 in. (2225 mm) |
| Width | 33 in. (838 mm) |
| Height | 49.75 in. (1264 mm) |
| Ground clearance | 6.75 in. (171.5 mm) |
| XL1200 Custom | |
| Wheelbase | 59.0 in. (1499 mm) |
| Length | |
| 1996-2001 models | 87.25 in. (2216 mm) |
| 2002-2003 models | 88.0 in. (2235 mm) |
| Width | |
| 1996-2001 models | 35 in. (889 mm) |
| Height | |
| 1996-2001 models | 49.75 in. (1264 mm) |
| Ground clearance | |
| 2002-2003 models | 6.70 in. (170 mm) |
| XL1200 Sport | |
| Wheelbase | 60.2 in. (1529 mm) |
| Length | |
| 1996-2001 models | 87.6 in. (2225 mm) |
| 2002-2003 models | 88.5 in. (2248 mm) |

(continued)

Table 2 GENERAL DIMENSIONS (continued)

| | | |
|---------------------------------|--|---------------------|
| XL1200 Sport (continued) | | |
| Width | | |
| 1996-2001 models | | 35 in. (889 mm) |
| 2002-2003 models | | 33 in. (838 mm) |
| Height | | |
| 1996-2001 models | | 49.75 in. (1264 mm) |
| 2002-2003 models | | 49.5 in. (1257 mm) |
| Ground clearance | | 6.70 in. (170 mm) |

Table 3 OVERALL MOTORCYCLE WEIGHT

| | | |
|----------------------|--|------------------|
| XLH883 | | |
| 1986-1990 models | | 463 lb. (210 kg) |
| 1991-1993 models | | 472 lb. (214 kg) |
| 1994-2003 models | | 488 lb. (221 kg) |
| XLH883 Custom | | 489 lb. (222 kg) |
| XLH883 Deluxe | | |
| 1986-1990 models | | 463 lb. (210 kg) |
| 1991-1993 models | | 484 lb. (220 kg) |
| 1994 models | | 494 lb. (224 kg) |
| XLH883 Hugger | | |
| 1987-1990 models | | 463 lb. (210 kg) |
| 1991-1993 models | | 472 lb. (214 kg) |
| 1994-2003 models | | 485 lb. (220 kg) |
| XL883R | | 503 lb. (228 kg) |
| XLH1100 | | 457 lb. (207 kg) |
| XLH1200 | | |
| 1988-1990 models | | 457 lb. (207 kg) |
| 1991-1993 models | | 470 lb. (213 kg) |
| 1994-1996 models | | 490 lb. (222 kg) |
| 1997-1998 models | | 494 lb. (224 kg) |
| 1999-2003 models | | 491 lb. (223 kg) |
| XL1200 Custom | | |
| 1996-1998 models | | 483 lb. (219 kg) |
| 1999-2003 models | | 491 lb. (223 kg) |
| XL1200 Sport | | |
| 1996-1998 models | | 497 lb. (225 kg) |
| 1997-2003 models | | 501 lb. (227 kg) |

Table 4 VEHICLE WEIGHT

| | | |
|--|--|------------------|
| Gross vehicle weight rating (GVWR)* | | |
| 1986-1994 models | | 900 lb. (408 kg) |
| 1995-2003 models | | 948 lb. (430 kg) |
| Gross axle weight ratings (GAWR) | | |
| Front | | |
| 1986-1994 models | | 320 lb. (145 kg) |
| 1995-2003 models | | 353 lb. (160 kg) |
| Rear | | |
| 1986-1994 models | | 580 lb. (263 kg) |
| 1995-2003 models | | 595 lb. (270 kg) |
| *GVWR is the combined weight of the vehicle, rider(s) and accessories. | | |

Table 5 FUEL TANK CAPACITY

| | Gal. | Liters |
|------------------|-------------|---------------|
| 1986-1994 models | | |
| Total | 2.25 | 8.5 |
| Reserve | 0.25 | 0.9 |
| (continued) | | |

Table 5 FUEL TANK CAPACITY (continued)

| | Gal. | Liters |
|----------------------|------|--------|
| 1995-1996 models | | |
| XLH883/XLH883 Hugger | | |
| Total | 2.25 | 8.5 |
| Reserve | 0.25 | 0.9 |
| All other models | | |
| Total | 3.30 | 12.5 |
| Reserve | 0.50 | 1.8 |
| 1997-2003 models | | |
| Total | 3.30 | 12.4 |
| Reserve | 0.50 | 1.8 |

Table 6 GENERAL TORQUE RECOMMENDATIONS (ft.-lb.)¹

| Type ² | 1/4 | 5/16 | 3/8 | 7/16 | 1/2 | 9/16 | 5/8 | 3/4 | 7/8 | 1 |
|-------------------|-----|------|-----|------|-----|------|-----|-----|-----|-----|
| SAE 2 | 6 | 12 | 20 | 32 | 47 | 69 | 96 | 155 | 206 | 310 |
| SAE 5 | 10 | 19 | 33 | 54 | 78 | 114 | 154 | 257 | 382 | 587 |
| SAE 7 | 13 | 25 | 44 | 71 | 110 | 154 | 215 | 360 | 570 | 840 |
| SAE 8 | 14 | 29 | 47 | 78 | 119 | 169 | 230 | 380 | 600 | 700 |

1. Convert ft.-lb. specification to N•m by multiplying by 1.3558.
 2. Fastener strength of SAE bolts can be determined by the bolt head grade markings. Unmarked bolt heads and cap screws are usually mild steel. More grade markings indicate higher fastener quality.



SAE 2



SAE 5



SAE 7

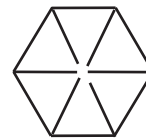

SAE 8

Table 7 CONVERSION FORMULAS

| Multiply: | By: | To get the equivalent of: |
|---------------------|-----------|---------------------------|
| Length | | |
| Inches | 25.4 | Millimeter |
| Inches | 2.54 | Centimeter |
| Miles | 1.609 | Kilometer |
| Feet | 0.3048 | Meter |
| Millimeter | 0.03937 | Inches |
| Centimeter | 0.3937 | Inches |
| Kilometer | 0.6214 | Mile |
| Meter | 3.281 | Feet |
| Fluid volume | | |
| U.S. quarts | 0.9463 | Liters |
| U.S. gallons | 3.785 | Liters |
| U.S. ounces | 29.573529 | Milliliters |
| Imperial gallons | 4.54609 | Liters |
| Imperial quarts | 1.1365 | Liters |
| Liters | 0.2641721 | U.S. gallons |
| Liters | 1.0566882 | U.S. quarts |
| Liters | 33.814023 | U.S. ounces |
| Liters | 0.22 | Imperial gallons |
| Liters | 0.8799 | Imperial quarts |
| Milliliters | 0.033814 | U.S. ounces |
| Milliliters | 1.0 | Cubic centimeters |
| Milliliters | 0.001 | Liters |

(continued)

Table 7 CONVERSION FORMULAS continued)

| Multiply: | By: | To get the equivalent of: |
|---------------------------------|--|----------------------------------|
| Torque | | |
| Foot-pounds | 1.3558 | Newton-meters |
| Foot-pounds | 0.138255 | Meters-kilograms |
| Inch-pounds | 0.11299 | Newton-meters |
| Newton-meters | 0.7375622 | Foot-pounds |
| Newton-meters | 8.8507 | Inch-pounds |
| Meters-kilograms | 7.2330139 | Foot-pounds |
| Volume | | |
| Cubic inches | 16.387064 | Cubic centimeters |
| Cubic centimeters | 0.0610237 | Cubic inches |
| Temperature | | |
| Fahrenheit | $(^{\circ}\text{F} - 32) \times 0.556$ | Centigrade |
| Centigrade | $(^{\circ}\text{C} \times 1.8) + 32$ | Fahrenheit |
| Weight | | |
| Ounces | 28.3495 | Grams |
| Pounds | 0.4535924 | Kilograms |
| Grams | 0.035274 | Ounces |
| Kilograms | 2.2046224 | Pounds |
| Pressure | | |
| Pounds per square inch | 0.070307 | Kilograms per square centimeter |
| Kilograms per square centimeter | 14.223343 | Pounds per square inch |
| Kilopascals | 0.1450 | Pounds per square inch |
| Pounds per square inch | 6.895 | Kilopascals |
| Speed | | |
| Miles per hour | 1.609344 | Kilometers per hour |
| Kilometers per hour | 0.6213712 | Miles per hour |

Table 8 TECHNICAL ABBREVIATIONS

| | |
|--------------------|--------------------------------|
| A | Ampere |
| AC | Alternating current |
| A• h | Ampere hour |
| C | Celsius |
| cc | Cubic centimeter |
| CDI | Capacitor discharge ignition |
| cm | Centimeter |
| cu. in. | Cubic inch and cubic inches |
| cyl. | Cylinder |
| DC | Direct current |
| F | Fahrenheit |
| fl. oz. | Fluid ounces |
| ft. | Foot |
| ft.-lb. | Foot pounds |
| gal. | Gallon and gallons |
| hp | Horsepower |
| Hz | Hertz |
| in. | Inch and inches |
| in.-lb. | Inch-pounds |
| in. Hg | Inches of mercury |
| kg | Kilogram |
| kg/cm ² | Kilogram per square centimeter |
| kgm | Kilogram meter |
| km | Kilometer |
| km/h | Kilometer per hour |
| kPa | Kilopascals |
| kW | Kilowatt |
| L | Liter and liters |
| L/m | Liters per minute |
| lb. | Pound and pounds |
| m | Meter |
| MAP | Manifold absolute pressure |
| | (continued) |

Table 8 TECHNICAL ABBREVIATIONS (continued)

| | |
|-----|-----------------------------|
| mL | Milliliter |
| mm | Millimeter |
| MPa | Megapascal |
| N | Newton |
| N•m | Newton meter |
| oz. | Ounce and ounces |
| p | Pascal |
| psi | Pounds per square inch |
| pt. | Pint and pints |
| qt. | Quart and quarts |
| rpm | Revolution per minute |
| TDC | Top dead center |
| V | Volt |
| VAC | Alternating current voltage |
| VDC | Direct current voltage |
| W | Watt |

Table 9 AMERICAN TAP AND DRILL SIZES

| Tap thread | Drill size | Tap thread | Drill size |
|------------|------------|------------|------------|
| #0-80 | 3/64 | 1/4-28 | No. 3 |
| #1-64 | No. 53 | 5/16-18 | F |
| #1-72 | No. 53 | 5/16-24 | I |
| #2-56 | No. 51 | 3/8-16 | 5/16 |
| #2-64 | No. 50 | 3/8-24 | Q |
| #3-48 | 5/64 | 7/16-14 | U |
| #3-56 | No. 46 | 7/16-20 | W |
| #4-40 | No. 43 | 1/2-13 | 27/64 |
| #4-48 | No. 42 | 1/2-20 | 29/64 |
| #5-40 | No. 39 | 9/16-12 | 31/64 |
| #5-44 | No. 37 | 9/16-18 | 33/64 |
| #6-32 | No. 36 | 5/8-11 | 17/32 |
| #6-40 | No. 33 | 5/8-18 | 37/64 |
| #8-32 | No. 29 | 3/4-10 | 21/32 |
| #8-36 | No. 29 | 3/4-16 | 11/16 |
| #10-24 | No. 25 | 7/8-9 | 49/64 |
| #10-32 | No. 21 | 7/8-14 | 13/16 |
| #12-24 | No. 17 | 1-8 | 7/8 |
| #12-28 | No. 15 | 1-14 | 15/16 |
| 1/4-20 | No. 8 | | |

Table 10 METRIC TAP AND DRILL SIZES

| Metric size | Drill equivalent | Decimal fraction | Nearest fraction |
|-------------|------------------|------------------|------------------|
| 3 × 0.50 | No. 39 | 0.0995 | 3/32 |
| 3 × 0.60 | 3/32 | 0.0937 | 3/32 |
| 4 × 0.70 | No. 30 | 0.1285 | 1/8 |
| 4 × 0.75 | 1/8 | 0.125 | 1/8 |
| 5 × 0.80 | No. 19 | 0.166 | 11/64 |
| 5 × 0.90 | No. 20 | 0.161 | 5/32 |
| 6 × 1.00 | No. 9 | 0.196 | 13/64 |
| 7 × 1.00 | 16/64 | 0.234 | 15/64 |
| 8 × 1.00 | J | 0.277 | 9/32 |
| 8 × 1.25 | 17/64 | 0.265 | 17/64 |
| 9 × 1.00 | 5/16 | 0.3125 | 5/16 |
| 9 × 1.25 | 5/16 | 0.3125 | 5/16 |
| 10 × 1.25 | 11/32 | 0.3437 | 11/32 |
| 10 × 1.50 | R | 0.339 | 11/32 |
| 11 × 1.50 | 3/8 | 0.375 | 3/8 |
| 12 × 1.50 | 13/32 | 0.406 | 13/32 |
| 12 × 1.75 | 13/32 | 0.406 | 13/32 |

Table 11 DECIMAL AND METRIC EQUIVALENTS

| Fractions | Decimal in. | Metric mm | Fractions | Decimal in. | Metric mm |
|-----------|-------------|-----------|-----------|-------------|-----------|
| 1/64 | 0.015625 | 0.39688 | 33/64 | 0.515625 | 13.09687 |
| 1/32 | 0.03125 | 0.79375 | 17/32 | 0.53125 | 13.49375 |
| 3/64 | 0.046875 | 1.19062 | 35/64 | 0.546875 | 13.89062 |
| 1/16 | 0.0625 | 1.58750 | 9/16 | 0.5625 | 14.28750 |
| 5/64 | 0.078125 | 1.98437 | 37/64 | 0.578125 | 14.68437 |
| 3/32 | 0.09375 | 2.38125 | 19/32 | 0.59375 | 15.08125 |
| 7/64 | 0.109375 | 2.77812 | 39/64 | 0.609375 | 15.47812 |
| 1/8 | 0.125 | 3.1750 | 5/8 | 0.625 | 15.87500 |
| 9/64 | 0.140625 | 3.57187 | 41/64 | 0.640625 | 16.27187 |
| 5/32 | 0.15625 | 3.96875 | 21/32 | 0.65625 | 16.66875 |
| 11/64 | 0.171875 | 4.36562 | 43/64 | 0.671875 | 17.06562 |
| 3/16 | 0.1875 | 4.76250 | 11/16 | 0.6875 | 17.46250 |
| 13/64 | 0.203125 | 5.15937 | 45/64 | 0.703125 | 17.85937 |
| 7/32 | 0.21875 | 5.55625 | 23/32 | 0.71875 | 18.25625 |
| 15/64 | 0.234375 | 5.95312 | 47/64 | 0.734375 | 18.65312 |
| 1/4 | 0.250 | 6.35000 | 3/4 | 0.750 | 19.05000 |
| 17/64 | 0.265625 | 6.74687 | 49/64 | 0.765625 | 19.44687 |
| 9/32 | 0.28125 | 7.14375 | 25/32 | 0.78125 | 19.84375 |
| 19/64 | 0.296875 | 7.54062 | 51/64 | 0.796875 | 20.24062 |
| 5/16 | 0.3125 | 7.93750 | 13/16 | 0.8125 | 20.63750 |
| 21/64 | 0.328125 | 8.33437 | 53/64 | 0.828125 | 21.03437 |
| 11/32 | 0.34375 | 8.73125 | 27/32 | 0.84375 | 21.43125 |
| 23/64 | 0.359375 | 9.12812 | 55/64 | 0.859375 | 22.82812 |
| 3/8 | 0.375 | 9.52500 | 7/8 | 0.875 | 22.22500 |
| 25/64 | 0.390625 | 9.92187 | 57/64 | 0.890625 | 22.62187 |
| 13/32 | 0.40625 | 10.31875 | 29/32 | 0.90625 | 23.01875 |
| 27/64 | 0.421875 | 10.71562 | 59/64 | 0.921875 | 23.41562 |
| 7/16 | 0.4375 | 11.11250 | 15/16 | 0.9375 | 23.81250 |
| 29/64 | 0.453125 | 11.50937 | 61/64 | 0.953125 | 24.20937 |
| 15/32 | 0.46875 | 11.90625 | 31/32 | 0.96875 | 24.60625 |
| 31/64 | 0.484375 | 12.30312 | 63/64 | 0.984375 | 25.00312 |
| 1/2 | 0.500 | 12.70000 | 1 | 1.00 | 25.40000 |

Table 12 SPECIAL TOOLS

| Tool description | Part No. | Manufacturer |
|--|--------------|--------------|
| Bearing installation tool handle | 33416-80 | JIMS |
| Belt tension gauge | HD-35381-A | H-D |
| Breakout box | HD-42682 | H-D |
| Breakout box adapters | HD-42962 | H-D |
| Bushing reamer tool | 1726-2 | JIMS |
| Clutch spring compression tool | 34761-84 | JIMS |
| Clutch spring compression tool | 38515-90/91 | JIMS |
| Clutch spring compression tool | HD-38515A | H-D |
| Connecting rod bushing hone | HD-35102 | H-D |
| Connecting rod bushing tool | 95970-32C | JIMS |
| Connecting rod clamp tool | 1284 | JIMS |
| Countershaft support plate | HD-37404 | H-D |
| Fork oil gauge | HD-59000A | H-D |
| Fork seal driver | HD-36583 | H-D |
| Fork spring compressor (1200S models) | HD-41549A | H-D |
| Fork spring plate tool | HD-41551 | H-D |
| Hose clamp pliers | HD-97087-65B | H-D |
| Ignition system harness test kit | HD-41404 | H-D |
| Main drive gear needle bearing installation tool | | |
| 1991-1994 models | HD-37842 | H-D |
| 1995-2003 models | HD-37842A | H-D |
| Main drive gear remover and installer | HD-35316-A | H-D |
| Multimeter | HD-35500 | H-D |
| Neway valve seat cutter set | HD-35758-B | H-D |

(continued)

Table 12 SPECIAL TOOLS (continued)

| Tool description | Part No. | Manufacturer |
|--|-----------------------|---------------------|
| Pinion gear locking tool | 2234 | JIMS |
| Pinion gear oil seal | See text | |
| Retaining ring tool | 1710 | JIMS |
| Rocker arm bushing reamer | HD-94804-57 | H-D |
| Scanalyzer | HD-41325 | H-D |
| Shock absorber spring compressor | HD-97010-52A | H-D |
| Speedometer tester | HD-41354 | H-D |
| Sprocket locking link | HD-38362 | H-D |
| Sprocket shaft bearing cone installer | HD-37047A/HD-42759 | H-D |
| Sprocket shaft bearing race | 2246/94547-80B | JIMS |
| Steering head bearing race installation tool | HD-39302 | H-D |
| Terminal pick | HD-39621-28 | H-D |
| Terminal tool | HD-97364-71 | H-D |
| Transmission cross plate | HD-35316-91 | H-D |
| Transmission gear spacing tool | HD-35820 | H-D |
| Vacuum pump | HD-23738 | H-D |
| Valve guide brush | HD-34751 | H-D |
| Valve guide driver handle/remover | HD-34740 | H-D |
| Valve guide hone | HD-34723 | H-D |
| Valve guide installation tool | HD-34731A | H-D |
| Valve guide reamer | HD-39932/HD-39932-CAR | H-D |

CHAPTER TWO

TROUBLESHOOTING

This chapter covers troubleshooting procedures. Each section provides typical symptoms and logical methods for isolating the cause(s). There may be several ways to solve a problem, but only a systematic approach will be successful in avoiding wasted time and possibly unnecessary parts replacement.

An engine needs three elements to run properly: correct air/fuel mixture, compression and a spark at the right time.

If one basic requirement is missing, the engine will not run.

Gather as much information as possible to aid in diagnosis. Never assume anything and do not overlook the obvious. Make sure there is fuel in the tank. Make sure the fuel shutoff valve is in the on position.

In most cases, specialized test equipment is not needed to determine whether repairs can be performed at home. On the other hand, be realistic and do not attempt repairs beyond personal capabilities.

If the motorcycle does require the attention of a professional, describe the symptoms, conditions and previous repair attempts accurately and fully. The more information a technician has available, the easier it will be to diagnose.

Refer to **Table 1** and **Table 2** at the end of this chapter.

STARTING THE ENGINE

Engine Fails to Start (Spark Test)

Perform the following spark test to determine if the ignition system is operating properly:

CAUTION

Before removing the spark plugs, clean all debris from the plug base and surrounding area. Dirt that falls into the cylinder causes rapid engine wear.

1. Disconnect the spark plug wire and remove the spark plug as described in Chapter Three.

NOTE

*A spark tester is a useful tool for testing spark output. **Figure 1** shows the Motion Pro Ignition System Tester (part No. 08-0122). This tool is inserted in the spark plug cap and its base is grounded against the cylinder head. The tool's air gap is adjustable, and it allows the visual inspection of the spark while testing the intensity of the spark.*

2. Cover the spark plug hole with a clean shop cloth to reduce the chance of gasoline vapors being emitted from the hole.



3. Insert the spark plug (**Figure 2**), or spark tester (**Figure 3**), into its plug cap and ground the spark plug base against the cylinder head. Position the spark plug so the electrode is visible.

WARNING

Mount the spark plug, or tester, away from the spark plug hole in the cylinder so the spark plug or tester cannot ignite the gasoline vapors in the cylinder. If the engine is flooded,

do not perform this test. The firing of the spark plug can ignite fuel ejected through the spark plug hole.

NOTE

If a spark plug is used, perform this test with a new spark plug.

4. Turn the ignition switch on.

WARNING

Do not hold the spark plug, wire or connector, or a serious electrical shock may result.

5. Turn the engine over. A crisp blue spark should be evident across the spark plug electrode or spark tester terminals.

6. If the spark is good, check for one or more of the following possible malfunctions:

- a. Obstructed fuel line or fuel filter.
- b. Low compression or engine damage.
- c. Flooded engine.
- d. Incorrect ignition timing.

NOTE

*If the engine backfires during starting, the ignition timing may be incorrect due to a defective ignition component. Refer to **Ignition Timing Adjustment** in Chapter Three for more information.*

7. If the spark is weak or if there is no spark, refer to *Engine is Difficult to Start* in this section.

Engine is Difficult to Start

Check for one or more of the following possible malfunctions:

1. Fouled spark plug(s).
2. Improperly adjusted enrichment valve.
3. Intake manifold air leak.
4. A plugged fuel tank filler cap.
5. Clogged fuel line.
6. Contaminated fuel system.
7. An improperly adjusted carburetor.
8. A defective ignition module.
9. A defective ignition coil.
10. Damaged ignition coil primary and/or secondary wires.
11. Incorrect ignition timing.
12. Low engine compression.
13. Incorrect engine oil viscosity.
14. Discharged battery.
15. A defective starter.
16. Loose or corroded starter and/or battery cables.
17. A loose ignition sensor and module electrical connector.
18. Incorrect pushrod length (intake and exhaust valve pushrods interchanged).

Engine Will Not Crank

Check for one or more of the following possible malfunctions:

1. Ignition switch turned off.
2. A faulty ignition switch.
3. Engine run switch in off position.
4. A defective engine run switch.
5. Loose or corroded starter and battery cables.
6. A discharged or defective battery.
7. A defective starter.
8. A defective starter solenoid.
9. A defective starter shaft pinion gear.
10. Slipping overrunning clutch assembly.
11. A seized piston(s).
12. Seized crankshaft bearings.
13. A broken connecting rod.

ENGINE PERFORMANCE

The following check lists assume the engine runs, but is not operating at peak performance. Refer to the following procedure(s) that best describes the symptom(s).

Spark Plugs Fouled

If the spark plugs continually foul, check for the following:

1. Severely contaminated air filter element.
2. Incorrect spark plug heat range.
3. Rich fuel mixture.
4. Worn or damaged piston rings.
5. Worn or damaged valve guide oil seals.
6. Excessive valve stem-to-guide clearance.
7. Incorrect carburetor float level.

Engine Runs But Misfires

1. Fouled or improperly gapped spark plugs.
2. Damaged spark plug cables.
3. Incorrect ignition timing.
4. Defective ignition components.
5. An obstructed fuel line or fuel shutoff valve.
6. Obstructed fuel filter.
7. Clogged carburetor jets.
8. Loose battery connection.
9. Wiring or connector damage.
10. Water or other contaminates in the fuel.
11. Weak or damaged valve springs.
12. Incorrect camshaft/valve timing.
13. Damaged valve(s).
14. Dirty electrical connections.
15. Intake manifold or carburetor air leak.
16. A plugged carburetor vent hose.
17. Plugged fuel tank vent system.

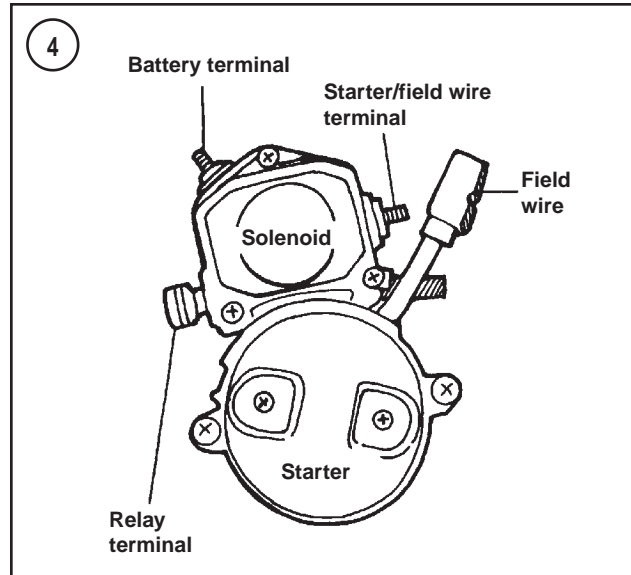

Engine Overheating

1. Incorrect carburetor adjustment or jet selection.
2. Incorrect ignition timing or defective ignition system components.
3. Improper spark plug heat range.
4. Low oil level.
5. Oil not circulating properly.
6. Leaking valves.
7. Heavy engine carbon deposits.

Engine Runs Rough with Excessive Exhaust Smoke

1. Clogged air filter element.
2. Rich carburetor adjustment.
3. Choke not operating correctly.
4. Water or other fuel contaminants.
5. Clogged fuel line and/or filter.
6. Spark plug(s) fouled.
7. Defective ignition components or wiring.
8. Short circuits from damaged wire insulation.
9. Loose battery cable connections.
10. Incorrect camshaft/valve timing.
11. Intake manifold or air filter air leak (carbureted models).

Engine Loses Power

1. Incorrect carburetor adjustment.
2. Engine overheating.
3. Incorrect ignition timing.
4. Incorrectly gapped spark plugs.
5. An obstructed muffler(s).
6. Dragging brake(s).

Engine Lacks Acceleration

1. Incorrect carburetor adjustment.

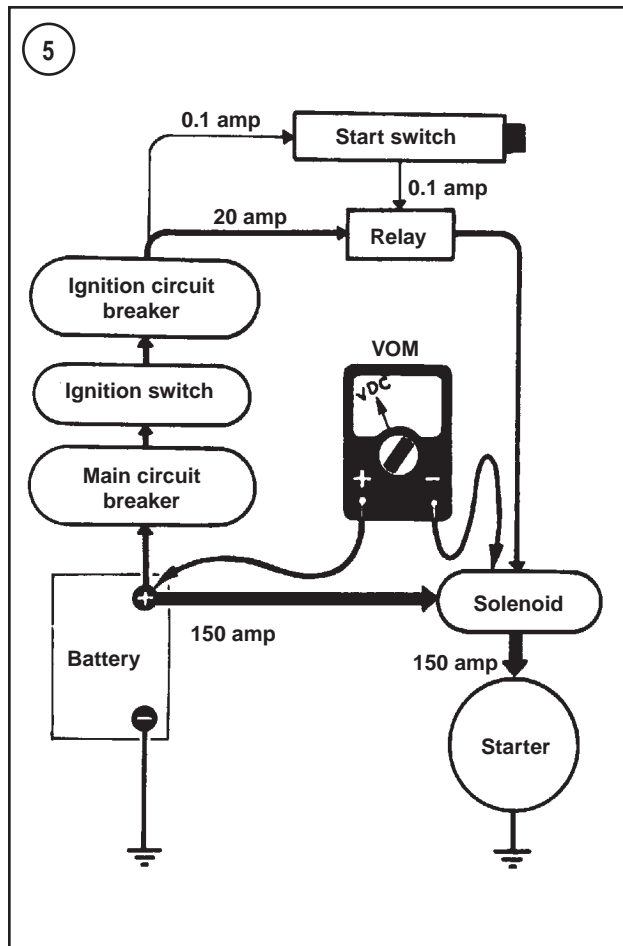

2. Clogged fuel line.
3. Incorrect ignition timing.
4. Dragging brake(s).

Valve Train Noise

1. A bent pushrod(s).
2. A defective hydraulic lifter(s).
3. A bent valve(s).
4. Rocker arm seizure or damage (binding on shaft).
5. Worn or damaged camshaft gear bushing(s).
6. Worn or damaged camshaft gear(s).
7. Worn or damaged camshaft drive chain(s).

ELECTRICAL COMPONENT REPLACEMENT

Most dealerships and suppliers will not accept the return of any electrical part. Consider and test results carefully before replacing a component that tests only slightly out of specification.

STARTING SYSTEM

The starting system consists of the battery, starter, starter relay, solenoid, start button, starter mechanism and related wiring.

When the ignition switch is turned on and the start button is pushed in, current is transmitted from the battery to the starter relay. When the relay is activated, it activates the starter solenoid that mechanically engages the starter with the engine.

Starting system problems are most often related to a loose or corroded electrical connection.

Refer to **Figure 4** for starter and solenoid terminal identification.

Troubleshooting Preparation

Before troubleshooting the starting system, check for the following:

1. The battery is fully charged.
2. Battery cables are the proper size and length. Replace damaged or undersized cables.
3. All electrical connections are clean and tight. High resistance caused from dirty or loose connectors can affect voltage and current levels.
4. The wiring harness is in good condition, with no worn or frayed insulation or loose harness sockets.
5. The fuel tank is filled with an adequate supply of fresh gasoline.
6. The spark plugs are in good condition and properly gapped.
7. The ignition system is working correctly.

Voltage Drop Test

Before performing the steps listed in *Starter Testing* in this section, perform this voltage drop test. These steps check the entire starting circuit to find weak or damaged electrical components that may be causing the starting system problem. A voltmeter is required to test voltage drop.

1. To check voltage drop in the solenoid circuit, connect the positive voltmeter lead to the positive battery terminal. Connect the negative voltmeter lead to the solenoid terminal (**Figure 5**).
2. Turn the ignition switch on and push the starter button while reading the voltmeter scale. Note the following:
 - a. The circuit is operating correctly if the voltmeter reading is 1 volt or less. A voltmeter reading of 12 volts indicates an open circuit.
 - b. A voltage drop of more than 1 volt indicates a problem in the solenoid circuit.
 - c. If the voltage drop reading is correct, continue with Step 3.

NOTE

Steps 3 and 4 check the voltage drop across the starter ground circuit. To check any ground circuit in the starting circuit, repeat this test and leave the negative voltmeter lead connected to the battery and connect the positive voltmeter lead to the ground in question.

- To check the starter ground circuit, connect the negative voltmeter lead to the negative battery terminal. Connect the positive voltmeter lead to the starter housing (**Figure 6**).
- Turn the ignition switch on and push the starter button while reading the voltmeter scale. The voltage drop must not exceed 0.2 volts. If it does, check the ground connections between the meter leads.
- If the problem is not found, refer to *Starter Testing* in this section.

Starter Testing**CAUTION**

Never operate the starter for more than 30 seconds at a time. Allow the starter to cool before reusing it. Failing to allow the starter to cool after continuous starting attempts can damage the starter.

The basic starter-related troubles are:

- Starter does not spin.
- Starter spins but does not engage.
- The starter will not disengage after the start button is released.
- Loud grinding noises when starter turns.
- Starter stalls or spins too slowly.

Starter does not spin

- Turn the ignition switch on and push the starter button while listening for a click at the starter relay in the electrical panel. Turn the ignition switch off and note the following:
 - If the starter relay clicks, test the starter relay as described in this section. If the starter relay test readings are correct, continue with Step 2.
 - If the solenoid clicks, go to Step 3.
 - If there was no click, go to Step 5.
- Check the wiring connectors between the starter relay and solenoid. Note the following:
 - Repair any dirty, loose fitting or damaged connectors or wiring.
 - If the wiring is in good condition, remove the starter as described in Chapter Twelve. Perform the solenoid and starter current draw bench tests described in this section.
- Perform a voltage drop test between the battery and solenoid terminals as described in this section. The normal voltage drop is less than 1 volt. Note the following:

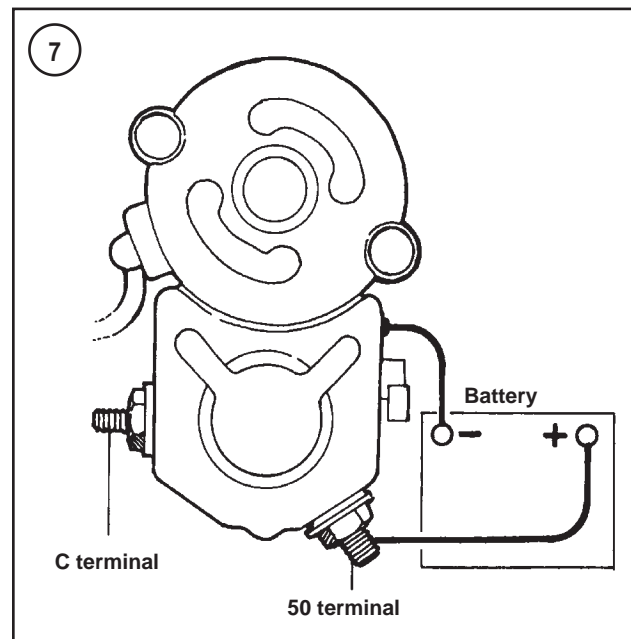
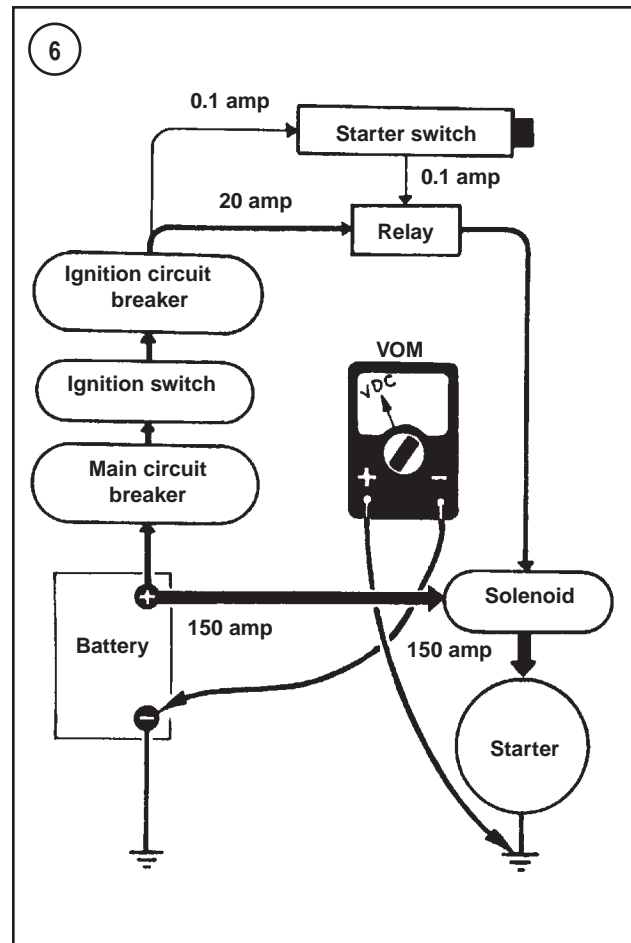

- If the voltage drop is less than 1 volt, perform Step 4.
- If the voltage drop is more than 1 volt, check the solenoid and battery wires and connections for dirty or loose fitting terminals; clean and repair as required.

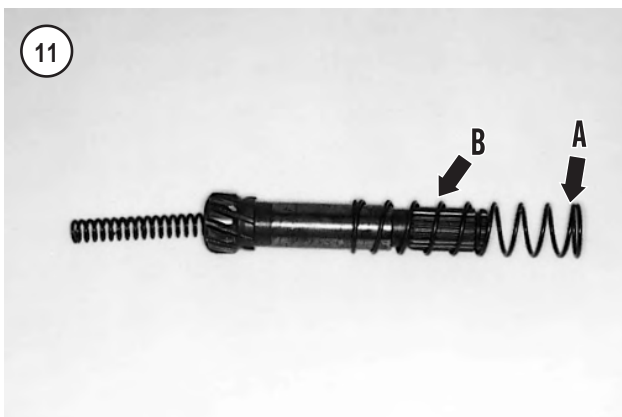
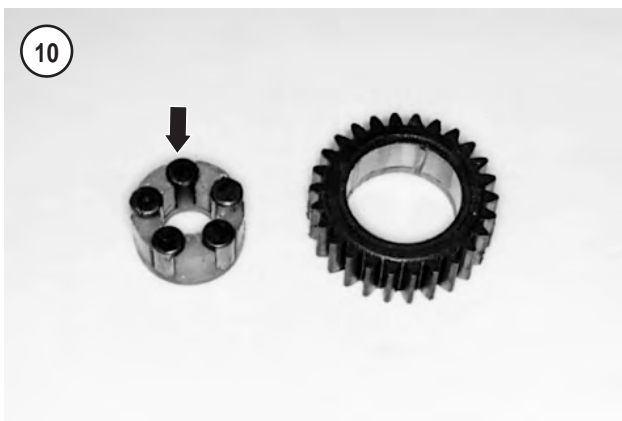
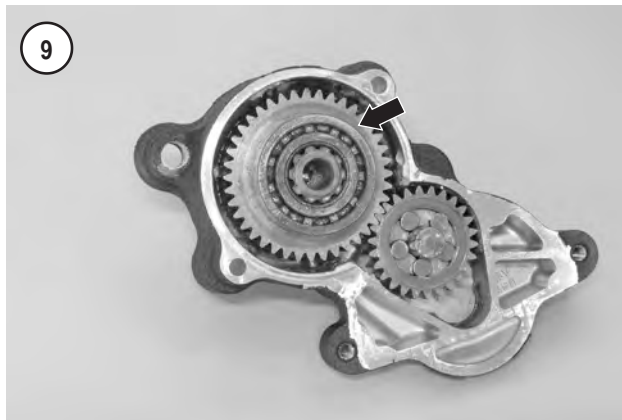
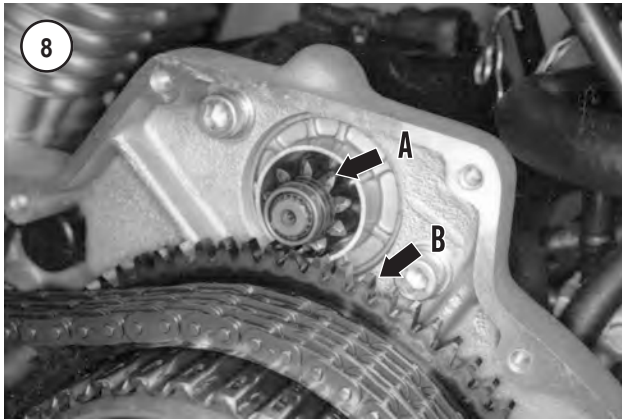

4. Remove the starter as described in Chapter Twelve. Momentarily connect a fully charged 12-volt battery to the starter as shown in **Figure 7**. If the starter is operational, it will turn when connected to the battery. Disconnect the battery and note the following:

- a. If the starter turns, perform the solenoid pull-in and hold-in tests as described in *Solenoid Testing (Bench Tests)* in this section.
- b. If the starter does not turn, disassemble the starter as described in Chapter Twelve, and check it for opens, shorts and grounds.

5. Check for voltage at the starter button. Note the following:

- a. If there is voltage at the starter button, test the starter relay as described in this section.
- b. If there is no voltage at the starter button, check continuity across the starter button. If there is voltage leading to the starter button but no voltage leaving the starter button, replace the button switch and retest. If there is no voltage leading to the starter button, check the starter button wiring for dirty or loose-fitting terminals or damaged wiring; clean and/or repair as required.

Starter spins but does not engage

If the starter spins but the pinion gear does not engage the clutch shell ring gear, perform the following:

1. Remove the primary drive cover as described in Chapter Six or Chapter Seven.
2. Check the starter pinion gear (A, **Figure 8**). If the teeth are chipped or worn, inspect the clutch shell ring gear (B, **Figure 8**) for the same problems. Note the following:
 - a. If the starter pinion gear or clutch ring gear is damaged, service the parts.
 - b. If the starter pinion gear and clutch shell ring gear are not damaged, continue with Step 3.
3. Remove and disassemble the starter as described in Chapter Twelve. Then check the overrunning clutch assembly (**Figure 9**) for the following:
 - a. Roller damage (**Figure 10**).
 - b. Compression spring damage (A, **Figure 11**).
 - c. Excessively worn or damaged pinion teeth (A, **Figure 8**).
 - d. Pinion does not run in overrunning direction.
 - e. Damaged clutch shaft splines (B, **Figure 11**).
 - f. Damaged overrunning clutch assembly (**Figure 12**).
4. Replace worn or damaged parts as required.

Starter will not disengage after the start button is released

1. A sticking solenoid, caused by a worn solenoid compression spring (A, **Figure 11**), can cause this problem. Replace the solenoid if damaged.
2. On high-mileage motorcycles, the starter pinion gear (A, **Figure 8**) can jam on a worn clutch ring gear (B). Unable to return, the starter will continue to run. This condition usually requires ring gear replacement.
3. Check the start button switch and starter relay for internal damage. Test the start switch as described in the *Switches* section in Chapter Twelve. Test the starter relay as described in this chapter.

Loud grinding noises when the starter turns

Incorrect starter pinion gear and clutch shell ring gear engagement (B, **Figure 8**) or a broken overrunning clutch mechanism (**Figure 12**) can cause this problem. Remove and inspect the starter as described in Chapter Twelve.

Starter stalls or spins too slowly

1. Perform a voltage drop test between the battery and solenoid terminals as described in this section. The normal voltage drop is less than 1 volts. Note the following:
 - a. If the voltage drop is less than 1 volt, continue with Step 2.
 - b. If the voltage drop exceeds 1 volt, check the solenoid and battery wires and connections for dirty or loose-fitting terminals; clean and repair as required.
2. Perform a voltage drop test between the solenoid terminals and the starter. The normal voltage drop is less than 1 volt. Note the following:
 - a. If the voltage drop is less than 1 volt, continue with Step 3.
 - b. If the voltage drop exceeds 1 volt, check the solenoid and starter wires and connections for dirty or loose-fitting terminals; clean and repair as required.
3. Perform a voltage drop test between the battery ground wire and the starter as described. The normal voltage drop is less than 0.2 volts. Note the following:
 - a. If the voltage drop is less than 0.2 volts, continue with Step 4.
 - b. If the voltage drop exceeds 0.2 volts, check the battery ground wire connections for dirty or loose-fitting terminals; clean and repair as required.
4. Refer to *Starter Current Draw Tests* in this section and perform the first test. Note the following:
 - a. If the current draw is excessive, check for a damaged starter. Remove the starter as described in Chapter Twelve and perform the second test.
 - b. If the current draw reading is correct, continue with Step 5.

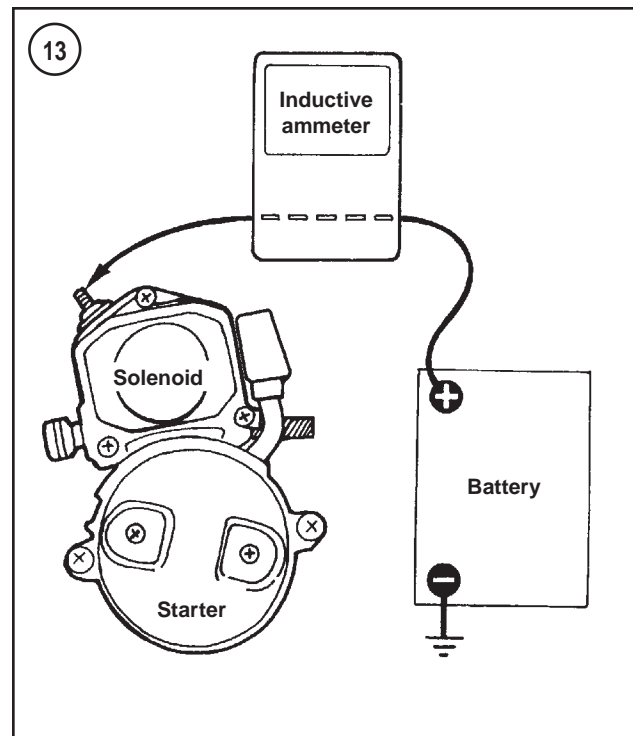

5. Remove the primary drive cover as described in Chapter Six or Chapter Seven. Check the starter pinion gear (A, **Figure 8**). If the teeth are chipped or worn, inspect the clutch ring gear (B, **Figure 8**) for the same problem.
 - a. If the starter pinion gear or clutch ring gear is damaged, service it.
 - b. If the starter pinion gear and clutch ring gear are not damaged, continue with Step 6.
6. Remove and disassemble the starter as described in Chapter Twelve. Check the disassembled starter for opens, shorts and grounds.

Starter Current Draw Tests

The following current draw test measures the current (amperage) the starter circuit requires to crank over the engine. Refer to **Table 1** for current draw specifications.

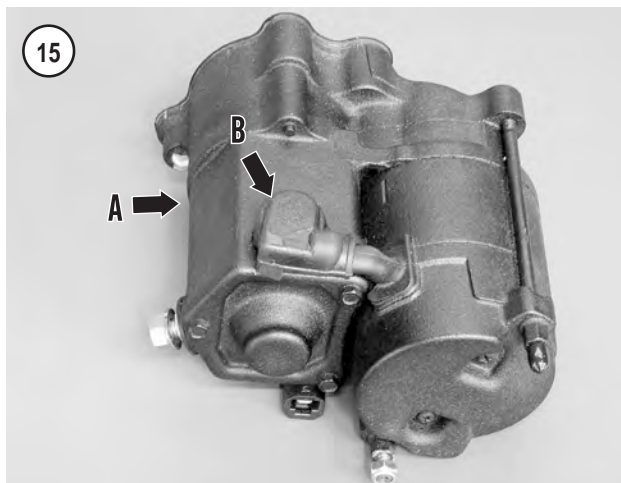
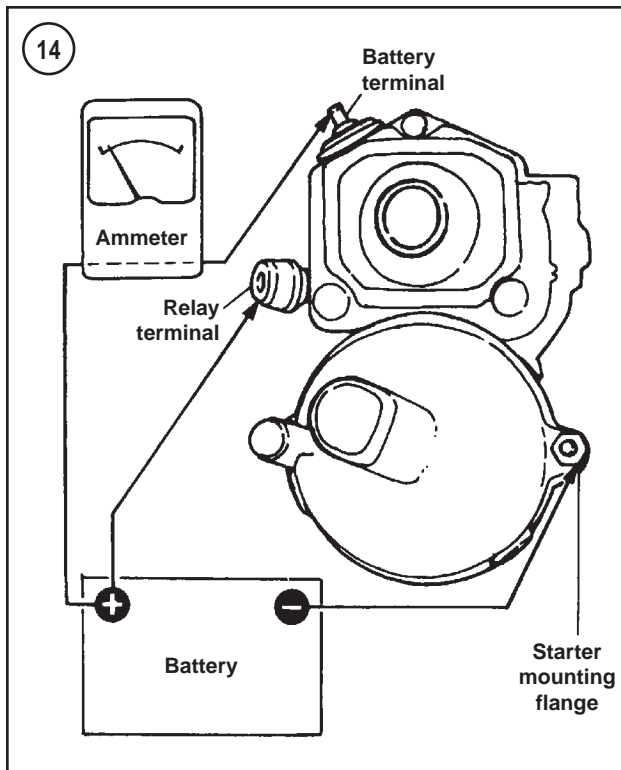

A short circuit in the starter or a damaged pinion gear assembly can cause excessive current draw. If the current draw is low, suspect an undercharged battery or an open circuit in the starting circuit.

Current draw test (starter installed)

NOTE

This test requires a fully charged battery and an inductive ammeter.

1. Shift the transmission into neutral.
2. Disconnect the two spark plug caps from the spark plugs. Then ground the plug caps with two extra spark

plugs or grounding tool. Do not remove the spark plugs from the cylinder heads.

3. Connect an inductive ammeter between the starter terminal and positive battery terminal (**Figure 13**). Connect a jumper cable from the negative battery terminal to ground (**Figure 13**).

4. Turn the ignition switch on and press the start button for approximately ten seconds. Note the ammeter reading.

NOTE

The current draw is high when the start button is first pressed, then it will drop and stabilize at a lower reading. Refer to the lower stabilized reading during this test.

5. If the current draw exceeds the specification in **Table 1**, check for a defective starter or starter drive mechanism. Remove and service these components as described in Chapter Twelve.

6. Disconnect the ammeter and jumper cables.

Current draw test (starter removed)

This test requires a fully charged 12-volt battery, an inductive ammeter, a jumper wire (14-gauge minimum) and three jumper cables (6-gauge minimum).

Refer to **Figure 14**.

1. Remove the starter as described in Chapter Twelve.

NOTE

The solenoid must be installed on the starter during the following tests.

2. Mount the starter in a vise with soft jaws.
3. Connect the 14-gauge jumper cable between the positive battery terminal and the solenoid relay terminal.
4. Connect a jumper cable (6-gauge minimum) between the positive battery terminal and the ammeter.
5. Connect the second jumper cable between the ammeter and the battery terminal on the starter solenoid.
6. Connect the third jumper cable between the battery negative terminal and the starter motor mounting flange.
7. Read the ammeter; the maximum no-load current specification is 90 amps. A damaged pinion gear assembly will cause an excessively high current draw reading. If the current draw reading is low, check for an undercharged battery, or an open field winding or armature in the starter.

Solenoid Testing (Bench Tests)

This test requires a fully charged 12-volt battery and three jumper wires.

1. Remove the starter as described in Chapter Twelve.

NOTE

*The solenoid (A, **Figure 15**) must be installed on the starter during the following tests.*

2. Disconnect the field wire (B, **Figure 15**) from the solenoid before performing the following tests. Insulate the end of the wire terminal so that it cannot short out on any of the test connectors.

CAUTION

Because battery voltage is being applied directly to the solenoid and starter in the following tests, do not leave the jumper cables connected to the solenoid for more than 5 seconds; otherwise, the voltage will damage the solenoid.

NOTE

Thoroughly read the following procedure to become familiar with and understand the procedures and test connections, then perform the tests in the order listed and without interruption.

3. Perform the solenoid pull-in test as follows:
 - a. Connect one jumper wire from the negative battery terminal to the field wire terminal on the solenoid (**Figure 16**).
 - b. Connect one jumper wire from the negative battery terminal to the solenoid housing (ground) (**Figure 16**).
 - c. Touch a jumper wire from the positive battery terminal to the starter relay terminal (**Figure 16**). The pinion shaft (**Figure 17**) should pull into the housing.
 - d. Leave the jumper wires connected and continue with Step 4.
4. To perform the solenoid hold-in test, perform the following:
 - a. With the pinion shaft pulled in (Step 3), disconnect the field wire terminal jumper wire from the negative battery terminal and connect it to the positive battery terminal (**Figure 18**). The pinion shaft should remain in the housing. If the pinion shaft returns to its original position, replace the solenoid.
 - b. Leave the jumper wires connected and continue with Step 5.
5. To perform the solenoid return test, perform the following:
 - a. Disconnect the jumper wire from the starter relay terminal (**Figure 19**); the pinion shaft should return to its original position.
 - b. Disconnect all of the jumper wires from the solenoid and battery.
6. Replace the solenoid if the starter shaft failed to operate as described in Steps 3-5. Refer to the *Starter Solenoid* in Chapter Twelve.

Starter Relay Removal/Testing/Installation

Check the starter relay operation with an ohmmeter, jumper wires and a fully charged 12-volt battery.

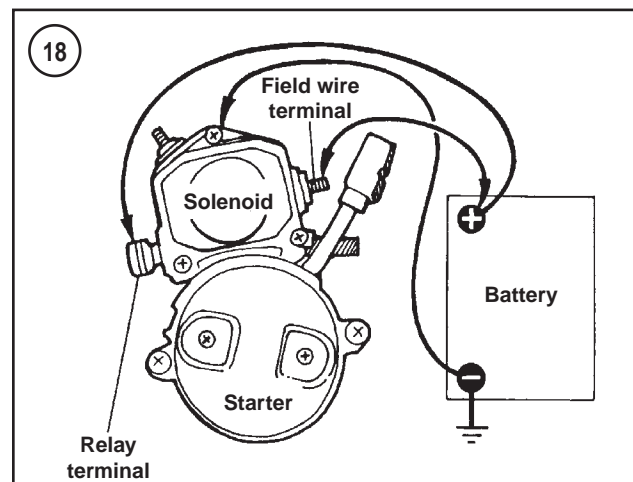
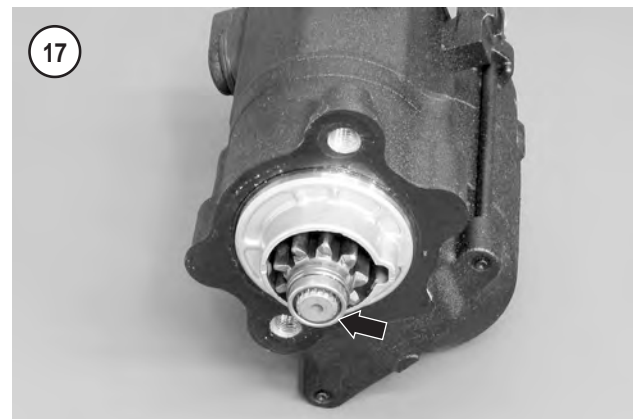
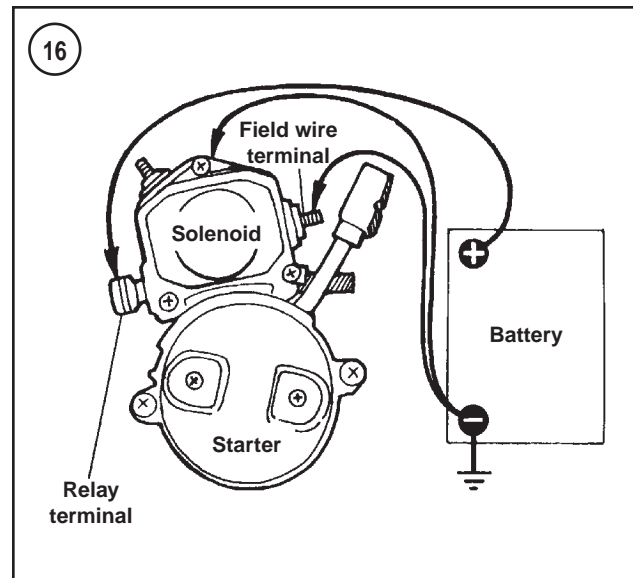

1. Remove the starter relay as described in *Fuses (1998-2003 Models)* in Chapter Twelve.

CAUTION

The battery negative lead must be connected to the relay terminal No. 2 to avoid internal diode damage.

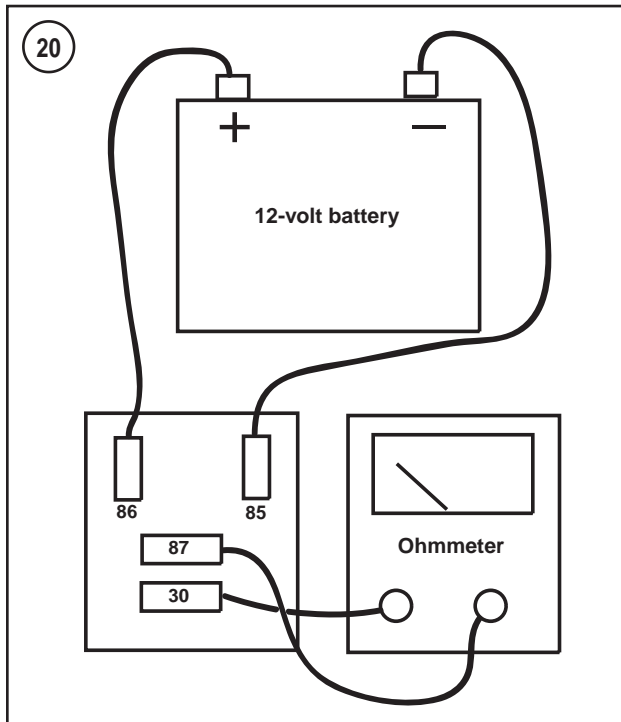
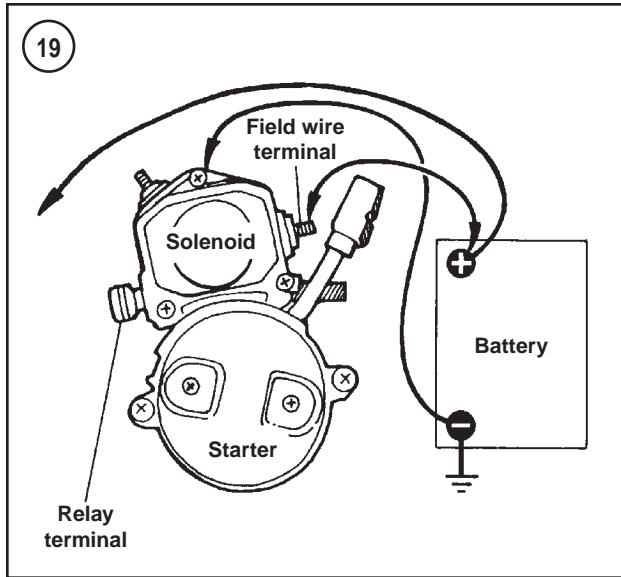

2. Connect an ohmmeter and 12-volt battery between the relay terminals shown in **Figure 20**. This setup will energize the relay for testing.
3. Check for continuity through the relay contacts using an ohmmeter while the relay coil is energized. The correct reading is 0 ohm. If resistance is excessive or if there is no continuity, replace the relay.
4. If the starter relay passes this test, reinstall the relay.

CHARGING SYSTEM

The charging system consists of the battery, alternator and a solid state voltage regulator/rectifier.

The alternator generates alternating current (AC) which the rectifier converts to direct current (DC). The regulator maintains the voltage to the battery and load (lights, ignition and accessories) at a constant voltage despite variations in engine speed and load.

A malfunction in the charging system generally causes the battery to remain undercharged.

Service Precautions

Before servicing the charging system, observe the following precautions to prevent damage to any charging system component:

1. Never reverse battery connections.
2. Do not short across any connection.
3. Never start the engine with the alternator disconnected from the voltage regulator/rectifier unless instructed to do so during testing.
4. Never attempt to start or run the engine with the battery disconnected.
5. Never attempt to use a high-output battery charger to help start the engine.
6. Before charging the battery, remove it from the motorcycle as described in Chapter Twelve.
7. Never disconnect the voltage regulator/rectifier connector with the engine running. The voltage regulator/rectifier (**Figure 21**) is mounted on the front frame cross member.
8. Do not mount the voltage regulator/rectifier unit in another location.
9. Make sure the negative battery terminal is connected to the terminal on the engine.

Troubleshooting Sequence

If the battery is discharged, perform the following procedures as listed:

1. Test the battery as described in Chapter Twelve. Charge the battery if necessary. If the battery will hold a charge while riding, perform the *Charging System Output Test* as described in this section.
2. If the charging system output is within specification, determine the total amount of current demand by the electrical

system and all accessories as described in *Electrical System Current Load Test* in this section.

3. If the charging system output exceeds the current demand and the battery continues to not hold a charge, perform the *Battery Current Draw Test* as described in this section.

4. If the charging system output is not within specification, test the stator and voltage regulator as described in this section.

Charging System Output Test

This test requires a load tester. When using a load tester, refer to the manufacturer's instructions.

1. To perform this test, the battery must be fully charged.
2. Connect the load tester to the battery per the manufacturer's instructions (**Figure 22**).
3. Start the engine and slowly bring the speed up to 3000 rpm while reading the load tester scale. With the engine running at 3000 rpm, operate the load tester switch until the voltage scale reads 13.0 volts. The tester should show a regulated (DC) current output reading of 19-23 amps.
4. With the engine still running at 3000 rpm, turn the load off and read the load tester voltage scale. Battery voltage should not exceed 15 volts. Turn the engine off and disconnect the load tester from the motorcycle.
5. Perform the *Stator Test* described in this section. If the stator tests acceptable, a defective voltage regulator/rectifier or a wiring short circuit is indicated. Eliminate the possibility of a poor connection or damaged wiring before replacing the voltage regulator/rectifier.

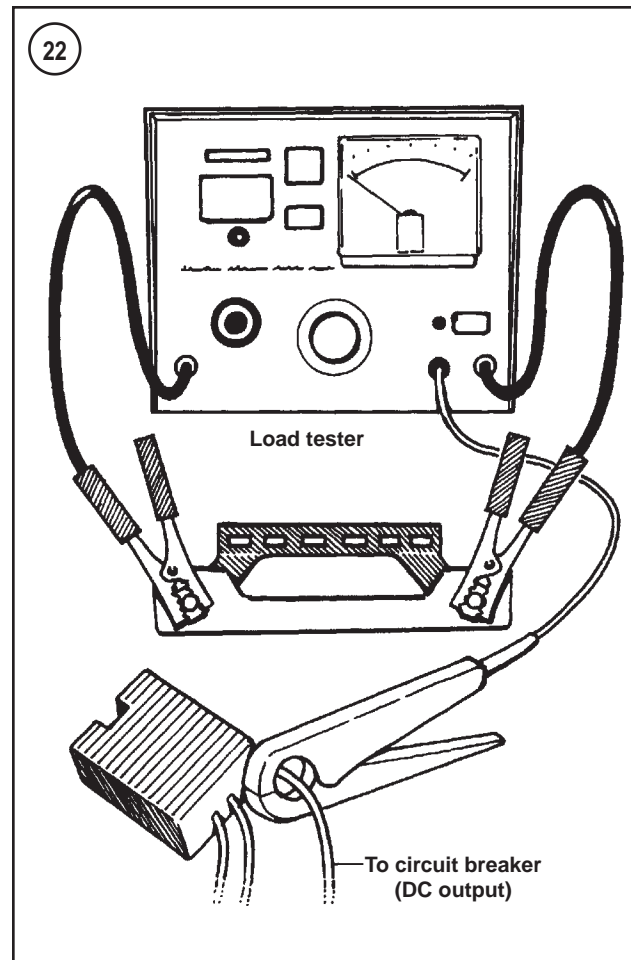

Electrical System Current Load Test

This test, requiring a load tester, measures the total current load of the electrical system and any additional accessories while the engine is running. Perform this test if the battery is continually discharged, yet the charging system output is within specifications.

If aftermarket electrical components have been added to the motorcycle, the increased current demand may exceed the charging systems capacity and result in a discharged battery.

1. Connect a load tester to the battery per the manufacturer's instructions. When using a load tester, refer to the manufacturer's instructions.
2. Turn the ignition switch on but do not start the engine. Then turn on all electrical accessories and switch the headlight beam to high.
3. Read the ampere reading (current draw) on the load tester and compare it to the test results obtained in the *Charging System Output Test* in this section. The charging system output test results (current reading) must exceed the electrical system current load by 3.5 amps for the battery to remain sufficiently charged.
4. If the current load is below specified levels and aftermarket accessories have been added to the motorcycle, dis-

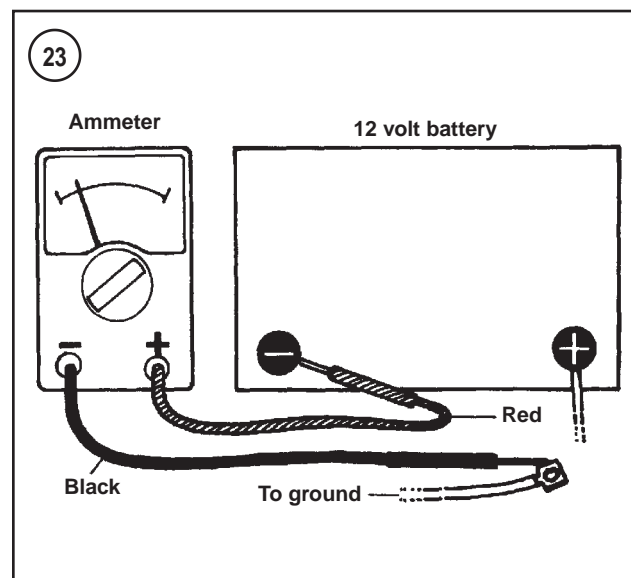

connect them and repeat Step 3. If the electrical system current load is now within the specification, the problem is with the additional accessories.

5. If no accessories have been added to the motorcycle, a short circuit may be causing the battery to discharge.

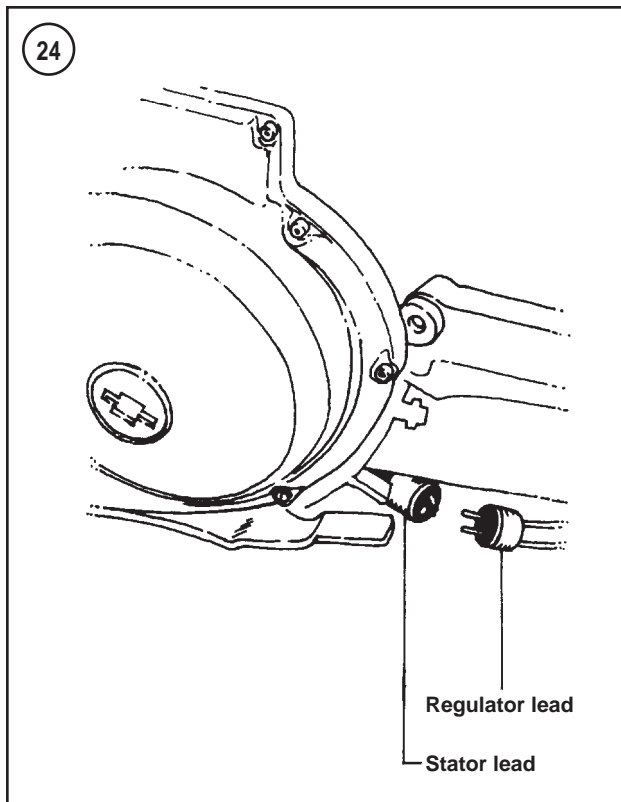

Battery Current Draw Test

Perform this test if the battery will not hold a charge when the motorcycle is not being used. A current draw that exceeds 3.0 mA will discharge the battery. The battery must be fully charged to perform this test.

1. Disconnect the negative battery cable as described in Chapter Twelve.
2. Connect an ammeter between the negative battery cable end and the ground stud on the engine crankcase as shown in **Figure 23**.
3. With the ignition switch, lights and all accessories turned off, read the ammeter. If the current drain exceeds 3.0 mA, continue with Step 4.

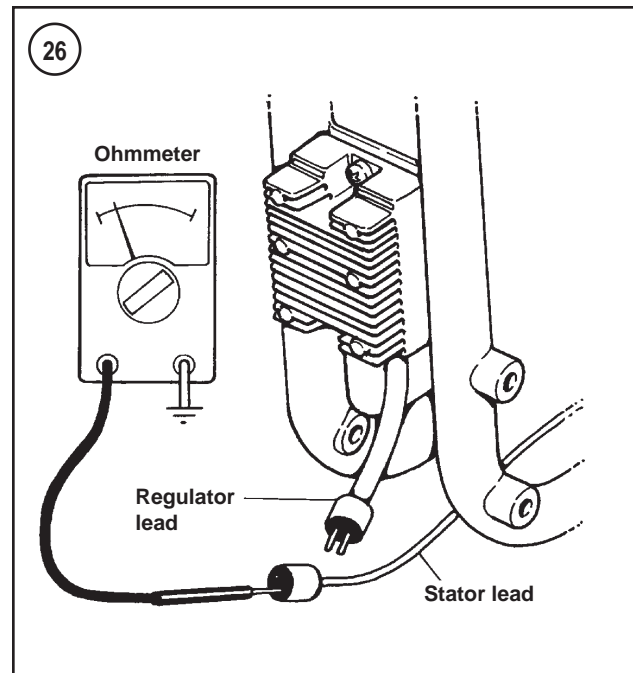

4. Refer to the appropriate wiring diagram at the end of this manual. Check the charging system wires and connectors for shorts or other damage.
5. Unplug each electrical connector separately and check for a reduction in the current draw. If the meter reading changes after a connector is disconnected, the source of the current draw has been found. Check the electrical connectors carefully before testing the individual component.
6. After completing the test, disconnect the ammeter and reconnect the negative battery cable.

Stator Test

1. With the ignition turned off, disconnect the regulator/rectifier connector that is located below the rear of the primary case (**Figure 24**) on 1986-1990 models or at the front of the crankcase (**Figure 25**) on 1991-2003 models.
2. Connect an ohmmeter between either stator connector terminal and ground (**Figure 26**). The ohmmeter should read infinity (no continuity). If the reading is incorrect, the stator is grounded and must be replaced. Repeat this test for the other stator connector terminal.
3. Connect an ohmmeter between both stator connector terminals. The ohmmeter should read 0.2-0.4 ohms. If the resistance is higher than specified, replace the stator.
4. Check stator AC output as follows:
 - a. Connect an AC voltmeter between the stator connector terminals as shown in **Figure 27**.
 - b. Start the engine and slowly increase idle speed. On 1986-1990 models, the voltage should read 12-18 volts per each 1000 rpm. On 1991-1994 models, the voltage should read 19-26 volts per each 1000 rpm. On 1995-2003 models, voltage should read 38-52 volts at 2000 rpm.

- c. If the AC voltage output reading is below the prescribed range, the trouble is probably a faulty stator (Figure 28, typical) or rotor. If these parts are not damaged, perform the *Charging System Output Test* in this section.

NOTE

On 1991-2003 models, if the stator AC output test indicate a faulty stator, check the stator wires where they are held in place by the flat metal clamp plate shown in Figure 29. The clamp plate may have rubbed through the wire's insulation.

5. Reconnect the regulator/rectifier connector.

Voltage Regulator Ground Test

1. Switch an ohmmeter to the appropriate scale.
2. Connect one ohmmeter lead to a good engine or frame ground and the other ohmmeter lead to the regulator base. Read the ohmmeter scale. The correct reading is 0 ohm. Note the following:
 - a. If there is low resistance (0 ohm), the voltage regulator is properly grounded.
 - b. If there is high resistance, remove the voltage regulator and clean its frame mounting points.
3. Check the voltage regulator connector (1986-1990 models: Figure 24 or 1991-2003 models: Figure 25) and make sure it is clean and tightly connected.

Voltage Regulator Bleed Test

1. Disconnect the voltage regulator connector (1986-1990 models: Figure 24 or 1991-2003 models: Figure 25). Do not disconnect the wire from the voltage regulator to the circuit breaker.
2. Connect one probe of a 12-volt test lamp to a good ground.
3. Connect the other test lamp probe to one of the voltage regulator pins, then to the other pin.
4. If the test lamp lights, replace the voltage regulator.
5. If the test lamp does not light the voltage regulator is functioning properly. Reconnect the voltage regulator connector.

IGNITION SYSTEM (1986-1997 MODELS)

Precautions

The following steps must be taken to protect the ignition system:

1. Never disconnect any of the electrical connectors while the engine is running.
2. Make sure all electrical connectors are free of corrosion and are completely coupled to each other.

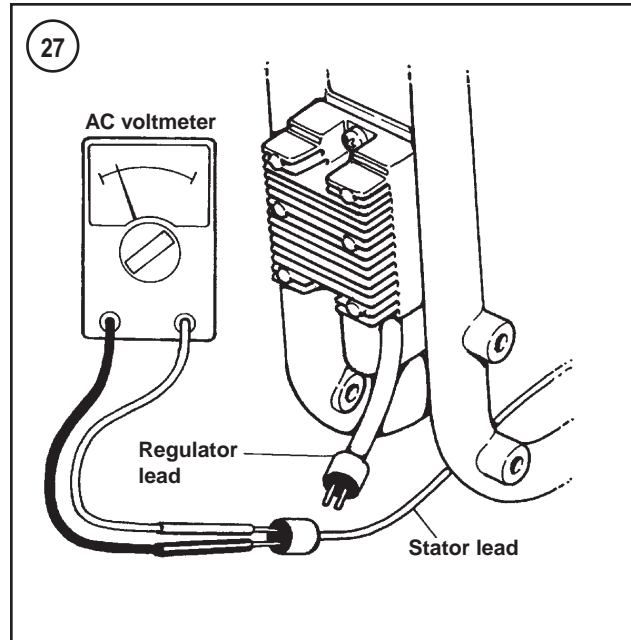

3. Do not operate the start switch if the ignition module is not grounded. The black ignition module wire is the ground wire. Inspect the wire end for corrosion and damage. Be sure the ignition module is mounted securely.
4. Apply dielectric grease to all electrical connectors prior to reconnecting them. This helps seal out moisture.

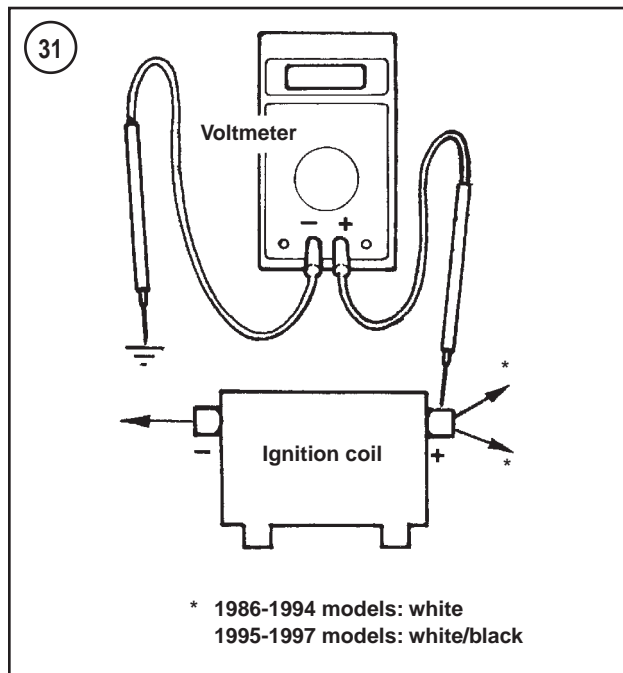
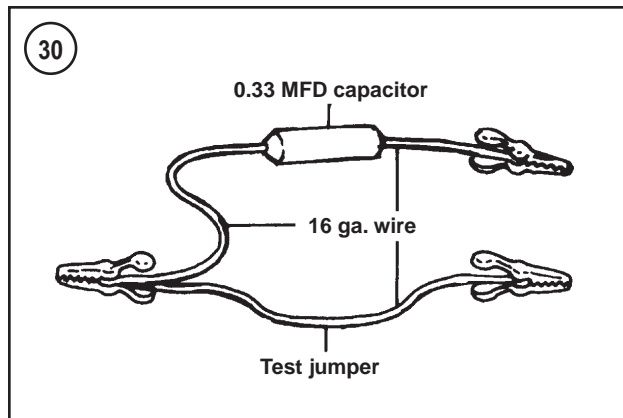

Troubleshooting Preparation

1. Refer to the wiring diagrams at the end of this manual for the specific model.
2. Check the wiring harness for visible signs of damage.
3. Make sure all connectors are properly attached to each other and locked in place.
4. Check all electrical components for a good ground.
5. Check all wiring for short circuits or open circuits.
6. Make sure all ignition circuit breakers or fuses are in good condition.
7. Make sure the fuel tank has an adequate supply of fresh gasoline.
8. Check the spark plug cable routing and the connections at the spark plugs. If there is no spark or only a weak one, repeat the test with new spark plugs. If the condition remains the same with new spark plugs and if all external wiring connections are good, the problem is most likely in the ignition system. If a strong spark is present, the problem is probably not in the ignition system. Check the fuel system.

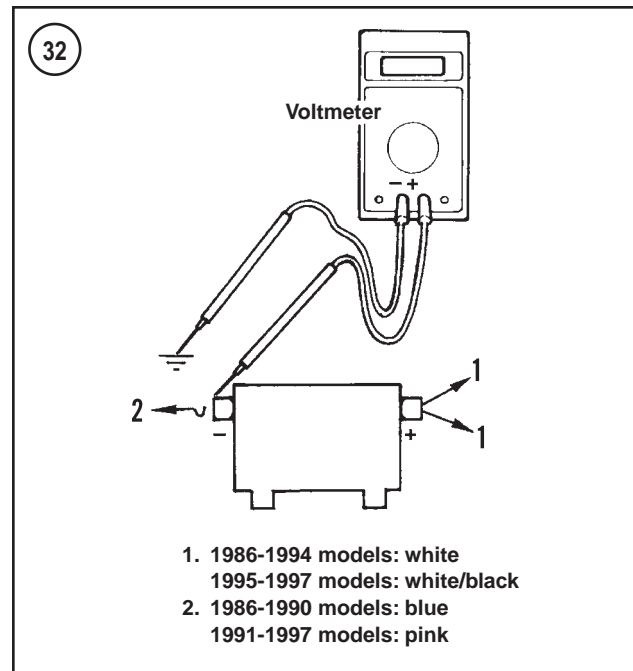

9. Remove the spark plugs and examine them as described in Chapter Three.

Ignition Tests

No spark at spark plug (1986-1990 models)

1. To perform this test, the battery must be fully charged (Chapter Twelve).
2. Make sure the black ignition module ground lead is fastened securely and make sure the battery ground lead is fastened and in good condition.

NOTE

When performing the following test procedures, it is necessary to fabricate a test jumper from two lengths of 16 gauge wire, three clips and a 0.33 MFD capacitor (**Figure 30**). The test jumper should be long enough to reach from the ignition coil to a good engine ground.

3. Perform the following:
 - a. Connect the positive voltmeter lead to the white ignition coil wire terminal and the negative voltmeter lead to ground (**Figure 31**).
 - b. Turn the ignition switch on. The voltmeter should read 11-13 volts. Turn the ignition switch off.
 - c. If the voltage is correct, proceed to Step 4.
 - d. If the voltage is incorrect, check the main and ignition circuit breakers (Chapter Twelve). Also check for loose or damaged ignition system wiring.
4. Perform the following:
 - a. Disconnect the blue wire from the ignition coil terminal (**Figure 32**).

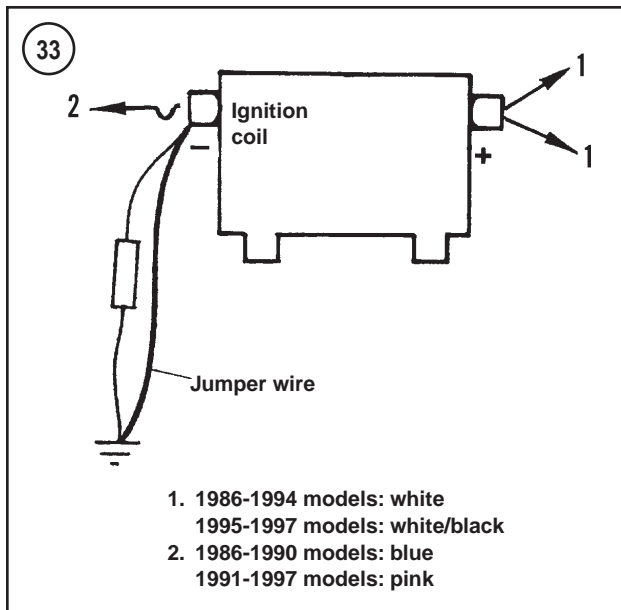

- Turn the ignition switch on.
 - Connect the negative voltmeter lead to ground. Connect the positive voltmeter lead to the white and blue ignition coil terminals (**Figure 33**). The voltmeter should read 12 volts at both terminals. Turn the ignition switch off.
 - If the voltage is correct, proceed to Step 5.
 - If the voltage is incorrect, check the ignition coil resistance as described in this section. If the resistance is within the prescribed range, proceed to Step 5.
5. Perform the following:
- Disconnect the blue wire from the ignition coil terminal (**Figure 33**) if not previously disconnected.
 - Remove one of the spark plugs. Then connect the spark plug wire and connector to the spark plug and touch the spark plug base to a good ground (**Figure 34**). Position the spark plug so the electrodes are visible.
 - Turn the ignition switch on.
 - Connect the jumper wire (without the capacitor) between a good engine ground and the ignition coil blue wire terminal as shown in **Figure 33**. Then momentarily touch the jumper wire with the capacitor to the ignition coil blue wire terminal (**Figure 33**) while observing the spark plug firing tip. The spark plug should spark. Turn the ignition switch off and remove the jumper wire assembly.
 - If there was spark, proceed to Step 6.
 - If there was no spark, replace the ignition coil.
 - Do not reinstall the spark plug at this time.
6. Perform the following:
- Reconnect the ignition coil blue wire to its terminal on the ignition coil.
 - Turn the ignition switch on.
 - Disconnect the sensor plate electrical connector located behind the sprocket cover.

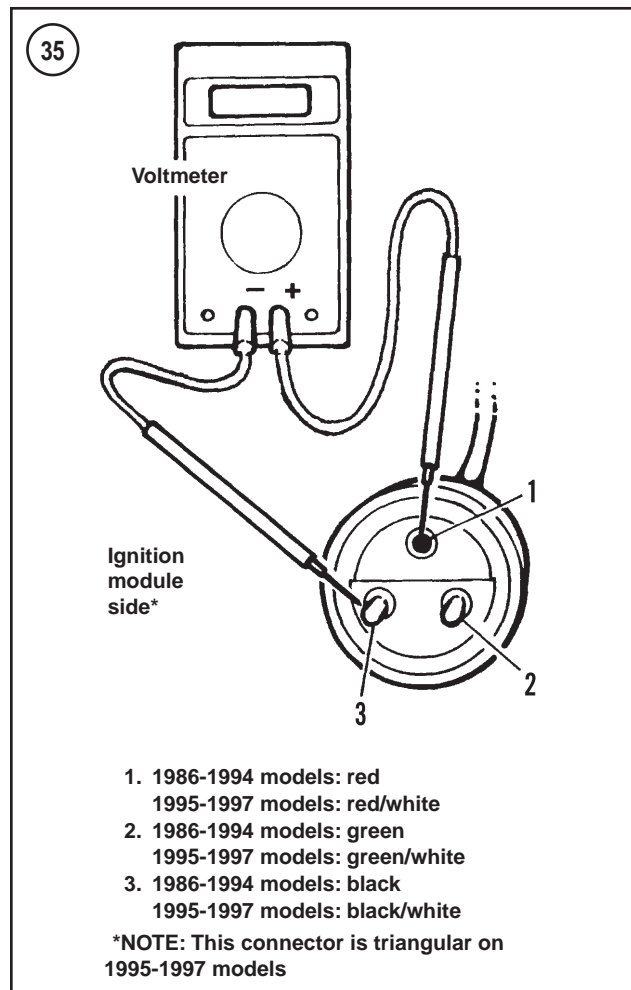

- Connect the positive voltmeter lead to the ignition module red wire socket and the negative voltmeter lead to the ignition module black pin as shown in **Figure 35**. The voltmeter should read 4.5-5.5 volts. Disconnect the voltmeter and turn the ignition switch off.
- If voltage is correct, proceed to Step 7.
- If voltage is incorrect, check the ignition module (**Figure 36**) ground wire and the module for dirty or loose-fitting terminals. If okay, proceed to Step 7.

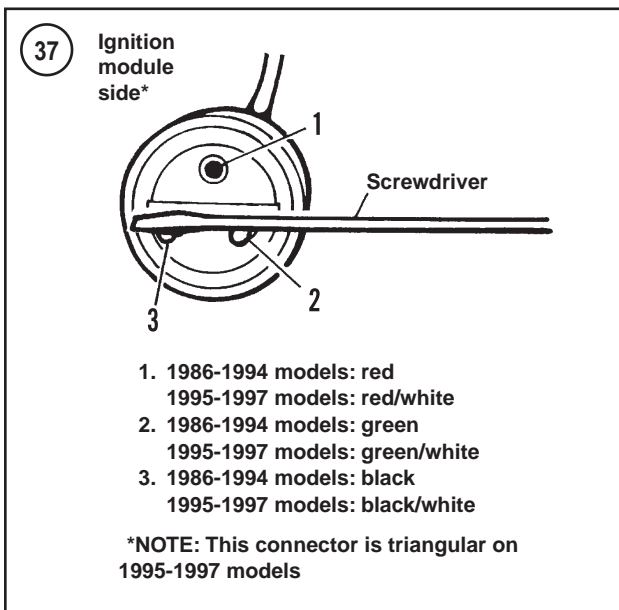

7. Make sure the ignition switch on. Then momentarily ground a screwdriver across the ignition module green and black connector pins (Figure 37) while observing the spark plug firing tip. There should be a strong spark at the spark plug firing tip as the screwdriver is removed. Note the following:

- If there was a spark, check the sensor resistance as described in this section.
- If there was no spark, check the ignition module resistance as described in this section.

8. Install and reconnect all parts removed for this procedure.

No spark at spark plug (1991-1997 models)

- To perform this test, the battery must be fully charged (Chapter Twelve).
- Make sure the black ignition module ground lead is fastened securely and make sure the battery ground lead is fastened and in good condition.

NOTE

When performing these test procedures, it is necessary to fabricate a test jumper from two lengths of 16 gauge wire, three clips and a 0.33 MFD capacitor; see Figure 30. The test jumper should be long enough to reach from the ignition coil to a good engine ground.

- Perform the following:
 - On 1991-1993 models, connect the positive voltmeter lead to the white ignition coil wire terminal and the negative voltmeter lead to ground (Figure 31). On 1994-1997 models, connect the positive voltmeter lead to the white/black ignition coil wire terminal and the negative voltmeter lead to ground (Figure 31).
 - Turn the ignition switch on. The voltmeter should read 11-13 volts. Turn the ignition switch off.
 - If the voltage is correct, proceed to Step 4.
 - If the voltage is incorrect, check the main and ignition circuit breakers or fuses (Chapter Twelve). Also check for loose or damaged ignition system wiring.
- Perform the following:
 - Disconnect the pink wire from the ignition coil terminal (Figure 32).
 - Turn the ignition switch on.
 - Connect the negative voltmeter lead to ground. On 1991-1993 models, connect the positive voltmeter lead to the white and pink ignition coil terminals separately. On 1994-1997 models, connect the positive voltmeter lead to the white/black and pink ignition coil terminals separately. The voltmeter should read 12 volts at both terminals. Turn the ignition switch off.
 - If the voltage is correct, proceed to Step 5.
 - If the voltage is incorrect, check the ignition coil resistance as described in this section. If the resistance is within the prescribed range, proceed to Step 5.
- Perform the following:
 - Disconnect the pink wire from the ignition coil terminal if not previously disconnected.
 - Remove one of the spark plugs. Then connect the spark plug wire and connector to the spark plug and touch the spark plug base to a good ground (Figure 34). Position the spark plug so the electrodes are visible.
 - Turn the ignition switch on.
 - Connect the jumper wire (without the capacitor) between a good ground and the ignition coil pink terminal (Figure 33). Then momentarily touch the jumper wire with the capacitor to the ignition coil pink terminal while observing the spark plug firing tip. The spark plug should spark when the wire is disconnected. Turn the ignition switch off and remove the jumper wire assembly.
 - If there is spark, proceed to Step 6.
 - If there is no spark, replace the ignition coil.
 - Do not reinstall the spark plug at this time.

6. Perform the following:
 - a. Reconnect the ignition coil pink wire to its terminal on the ignition coil.
 - b. Turn the ignition switch on.
 - c. Disconnect the sensor plate electrical connector (**Figure 38**).
 - d. On 1991-1993 models, connect the positive voltmeter lead to the ignition module red wire socket and the negative voltmeter lead to the ignition module black/white pin as shown in **Figure 35**. On 1994-1997 models, connect the positive voltmeter lead to the ignition module red/white wire socket and the negative voltmeter lead to the ignition module black/white pin as shown in **Figure 35**. The voltmeter should read 11.5-12.5 volts. Disconnect the voltmeter and turn the ignition switch off.
 - e. If the voltage is correct, proceed to Step 7.
 - f. If the voltage is incorrect, check the ignition module (**Figure 36**) ground wire and the module for dirty or loose-fitting terminals. If okay, proceed to Step 7.
- 7A. On 1991-1993 models, turn the ignition switch on. Then momentarily ground a screwdriver across the ignition module green and black/white connector pins (**Figure 37**) while observing the spark plug firing tip. There should be a strong spark at the spark plug firing tip as the screwdriver is removed.
 - a. If there is spark, check the sensor resistance as described in this chapter.
 - b. If there is no spark, check the ignition module resistance as described in this chapter.
- 7B. On 1994-1997 models, turn the ignition switch on. Then momentarily ground a screwdriver across the ignition module green/white and black/white connector pins (**Figure 37**) while observing the spark plug firing tip. There should be strong spark at the spark plug firing tip as the screwdriver is removed.
 - a. If there is spark, check the sensor resistance as described in this chapter.
 - b. If there is no spark, check the ignition module resistance as described in this chapter.
8. Install and reconnect all parts removed for this procedure.

Intermittent Ignition Problems

Intermittent problems are usually caused by temperature or vibration variances. Perform the following.

Temperature test

NOTE

Perform Steps 1-3 with the engine cold.

1. Remove the outer timing cover, inner timing cover and gasket as described in Chapter Twelve.
2. Start the engine.



3. Spray the sensor (**Figure 38**) with a refrigerant (available at electronic supply stores). If the engine dies, replace the sensor as described in Chapter Twelve.
4. Allow the engine to warm to normal operating temperature. Then apply heat to the sensor with a heat gun. If the engine dies, replace the sensor as described in Chapter Twelve.
5. Remove the ignition module cover from the left side of the motorcycle. With the engine running, apply heat to the ignition module (**Figure 36**) with a heat gun. If the engine dies, replace the module as described in Chapter Twelve.
6. Install the inner timing cover, gasket and outer timing cover as described in Chapter Twelve.

Vibration test

Read this procedure completely before starting. Refer to **Figure 39**.

1. Check the battery connections. Retighten or repair as required.
2. On 1986-1993 models, check the module ground wire connection. If necessary, remove the ground wire at the frame and scrape all paint at the mounting point. Using a star washer, reinstall the ground wire.
3. Start the engine and retest. If there is still an intermittent problem, proceed to Step 4.
- 4A. On 1986-1993 models, disconnect the white ignition stop switch wire terminal at the ignition coil. On 1986-1993 models, do not disconnect the white module wire at the ignition coil. Refer to the wiring diagram at the end of the manual.
- 4B. On 1994-1997 models, leave the white/black wire connected.
- 5A. On 1986-1993 models, connect a 16 ga. jumper wire from the positive battery terminal to the white ignition coil terminal.
- 5B. On 1994-1997 models, connect a 16 ga jumper wire from the positive battery terminal to the white/black wire ignition coil terminal.

WARNING

Steps 4 and 5 have bypassed the ignition stop switch. When performing Step 6, the engine

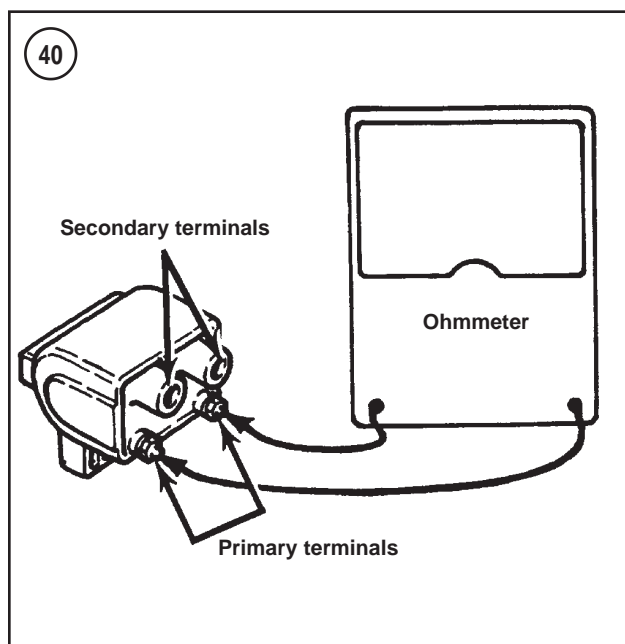
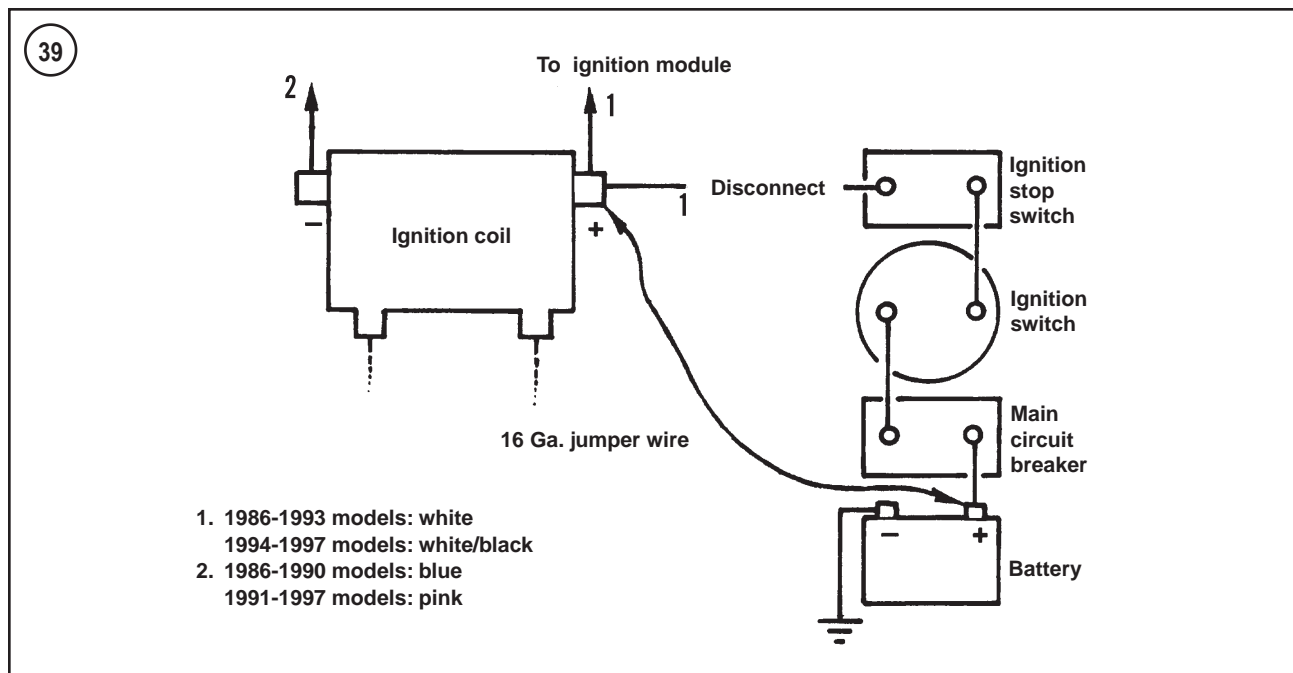

can only be stopped by removing the jumper wire. Test by removing the jumper wire before riding the motorcycle. It is suggested to test ride the motorcycle on a paved surface in a secluded area away from all traffic. If you do not feel that you can perform this test safely, or if you do not have access to a safe riding area, refer testing to a dealership.

6. Test-ride the motorcycle. If the problem has stopped, use voltage drop and wiggle tests to identify an intermittent open caused by a broken wire, poor connection, or defective switch in the starter safety circuit. If the problem con-

tinues, look for an intermittent open in the ignition control module and cam position sensor wiring.

7. Stop the motorcycle and then shift it into neutral. Disconnect the jumper wire and reconnect the white wire (1986-1993 models) at the ignition coil terminal.

Ignition Coil Testing

Disconnect the coil secondary and primary wires before testing. Refer to **Figure 40**. Compare readings to specifications noted in **Table 2**.

NOTE

When switching between ohmmeter scales in the following tests, always cross the test leads and zero the needle to assure a correct reading (analog meter only).

1. Measure the coil primary resistance between both coil primary terminals.
2. Measure the coil secondary resistance between both secondary terminals.
3. Replace the ignition coil if either test is not within specification.

Ignition Control Module and Sensor Resistance Testing (1986-1990 Models)

The following tests require a Fluke 23 or Harley-Davidson KMT multimeter (part No. HD35500). If any other meter is used, the results may be different than the specified values listed in these tests.

Ignition module ground test

1. Remove the outer timing cover, inner timing cover and gasket as described in Chapter Twelve
2. Disconnect the sensor (**Figure 38**).
3. Connect the ohmmeter positive lead to the module connector black pin and the ohmmeter negative lead to ground.
4. The correct resistance reading should be 0-1 ohms. If the reading exceeds 1 ohm, replace the module.
5. Reconnect the connector.

Power supply diode test

1. Disconnect the white ignition coil-to-module connector (**Figure 39**).
2. Connect the ohmmeter positive lead to the white ignition coil connector and the negative lead to the module ground wire. The resistance should be 800-1300 ohms.
3. Switch the test leads. The ohmmeter reading should be infinite.
4. Replace the module if any test readings are incorrect.
5. Reconnect the ignition coil-to-module connector.

Coil driver transistor check

1. Disconnect the blue ignition coil-to-module connector (**Figure 39**).
2. Connect the ohmmeter positive lead to the blue ignition coil connector and the negative lead to the module ground wire. The ohmmeter reading should be infinite.
3. Switch the test leads. The resistance should be 400-800 ohms.
4. Replace the module if any readings is incorrect.
5. Reconnect the ignition coil-to-module connector.

Ignition sensor ground test

1. Remove the outer timing cover, inner timing cover and gasket as described in Chapter Twelve.
2. Disconnect the sensor (**Figure 38**).
3. Connect the ohmmeter positive lead to the sensor connector red pin and the ohmmeter negative lead onto the sensor plate.
4. The ohmmeter should read infinite resistance.
5. Check the sensor connector black and green pins. In each case, the ohmmeter should read infinite resistance.
6. If any reading other than infinite was recorded, replace the sensor plate.
7. Reconnect the sensor connector.

Ignition sensor output test

1. Remove the outer timing cover, inner timing cover and gasket as described in Chapter Twelve.
2. Disconnect the sensor connector (**Figure 38**).

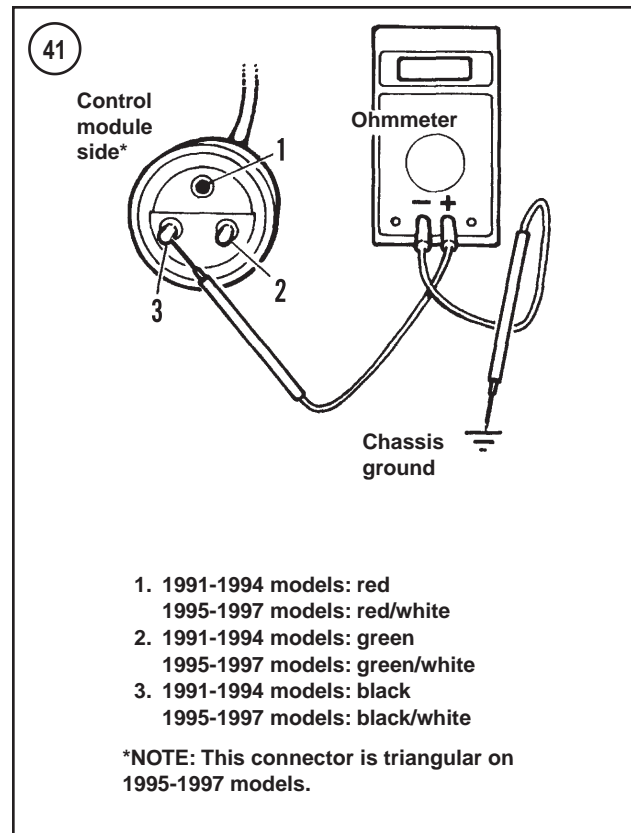

3. Connect the ohmmeter positive lead to the sensor connector green pin and the ohmmeter negative lead to the sensor connector black pin. The correct resistance reading should be infinite.
4. Switch the test leads. The resistance reading should be 300-750 ohms.
5. Replace the sensor plate if any test readings are incorrect.
6. Reconnect the module to sensor connector.

Ignition Module and Sensor Resistance Testing (1991-1997 Models)

The following tests require a Fluke 23 or Harley-Davidson KMT multimeter (part no. HD35500). If any other meter is used, the results may be different than the specified values listed in these tests.

Refer to **Figure 41**.

1. Disconnect the battery negative terminal. (Chapter Twelve).
2. Remove the outer timing cover, inner timing cover and gasket as described in Chapter Twelve
3. Disconnect the sensor (**Figure 38**).
4. Connect the positive ohmmeter lead to the black module pin and the negative ohmmeter lead to ground.
5. The correct resistance reading is 0-1 ohm. If the reading exceeds 1 ohm, replace the module.
6. Reconnect the connector.



Ignition Module Harness Resistance Test (1991-1997 Models)

Refer to **Figure 43**

1. Turn the ignition stop switch (**Figure 42**) to the off position.
2. Disconnect the 7-prong ignition module electrical connector.
3. Disconnect the sensor plate 3-prong electrical connector.
4. On 1991-1993 models connect the positive ohmmeter lead to the No. 4 ignition module connector on the wiring harness side, not on the module side. On 1994-1997 models connect the positive ohmmeter lead to pin No. 7 on the ignition module connector on the wiring harness side, not on the module side. Connect the negative ohmmeter lead to a good engine ground. Wiggle the wiring harness and read the resistance indicated on the ohmmeter. It should be 0-1 ohm. Note the following:
 - a. If the resistance reading is correct, perform Step 5.
 - b. If a high resistance reading is obtained, check for dirty or loose-fitting terminals or a bare or damaged wire; clean and repair as required.
5. Connect the positive ohmmeter lead to the No. 1 ignition module connector socket on the wiring harness side, not on the module side. Connect the negative ohmmeter lead to a good ground. Wiggle the wiring harness and read the ohmmeter scale. It should be infinity (high resistance). Note the following:
 - a. If the reading is infinity, perform Step 6.
 - b. If the meter shows a resistance reading, the wire is shorting to ground. Repair the wire and retest.
 - c. On 1991-1993 models, repeat this test for the following ignition module connector sockets: No. 2, 3, 5, 6 and 7.
 - d. On 1994-1997 models, repeat this test for the following ignition module connector sockets: No. 2, 3, 4, 5 and 6.
6. Check each of the ignition module socket wires (except No. 4 on 1991-1993 models or No. 7 on 1994-1997 models) for continuity with an ohmmeter set on the appropriate scale. The reading for each wire should be 0-1 ohm. An infinite reading indicates that there is an open in the wire; check for a dirty, loose-fitting or a damaged connector or wire. Repair as needed and retest.

IGNITION SYSTEM (ALL 1998-2003 MODELS [EXCEPT 1200S MODELS])

Review *Precautions* and *Troubleshooting Preparation in Ignition System (1986-1997 Models)* in this chapter.

Refer to the wiring diagrams at the end of this manual.

Tools

Troubleshooting the ignition system requires a breakout box (part No. HD-42682) as well as the breakout box harness adapters (part No. HD-42962). When connected inline in the ignition system, the breakout box provides test points for checking a live circuit.

If the breakout box is not available, fabricate a test harness (**Figure 44**) from 12 lengths of 16-gauge wire, a male Deutsch (6-pin) connector and two female Deutsch connectors (6-socket). Wire the No. 1 pin on the male connector to the No. 1 socket on each female connector. No. 2 pin to No. 2 socket, etc.

During testing, connect the harness between the two ends of the ignition control module connector (**Figure 45**) when instructed to install the test harness. Probe the second female connector at the indicated test points.

Troubleshooting the ignition system also requires the Harley-Davidson harness test kit (part No. HD-41404). Different-sized terminals are used in the connectors on a Sportster. This kit is equipped with different-sized probes for checking the voltage and resistance of the various-sized terminals without damaging the wire insulation.

Troubleshooting Tests

1. Perform the procedures described in *Troubleshooting Preparation* in this chapter.
2. Perform the spark test described in *Starting the engine* in this chapter.
 - a. If there is good spark, the problem is not in the ignition system. Check the fuel system.
 - b. If there is no spark or only a weak one, recheck with a new spark plug(s). If the condition remains the same with new spark plugs and if all external wiring connections are good, the problem is most likely in the ignition system; perform the *Ignition Test (Continuous or No Spark at Spark Plug)* described in this section.

Ignition Test (Continuous or No Spark at Spark Plug)

1. To perform this test, the battery must be fully charged. Check the battery as described in Chapter Twelve.
2. Make sure the ignition module ground is good.

NOTE

When performing the following test procedures, it will be necessary to fabricate a test

43

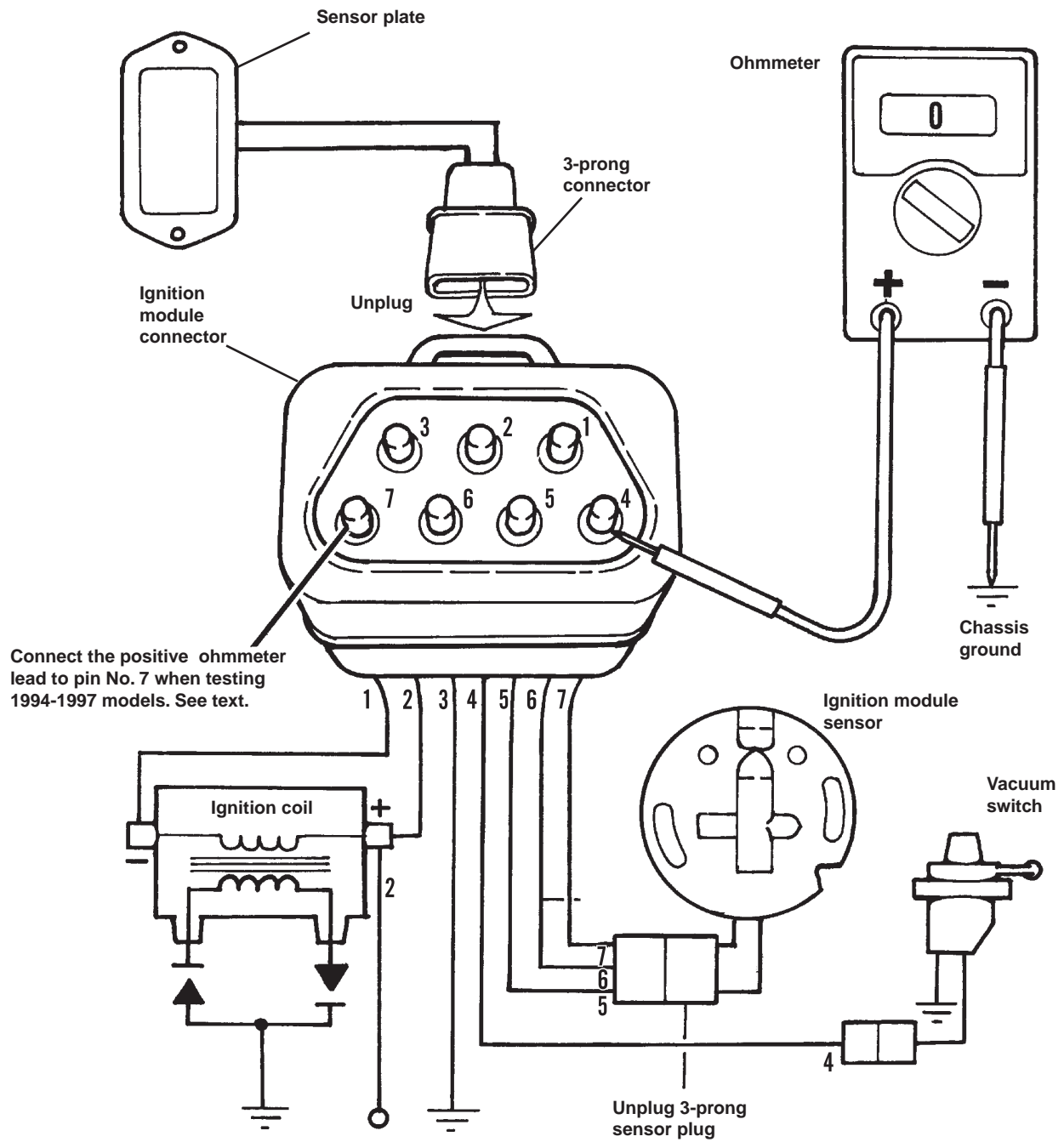

- 1. 1991-1997 models: pink
- 2. 1991-1997 models: white
- 3. 1991-1997 models: black
- 4. 1991-1997 models: violet/white
- 5. 1991-1993 models: green
1994-1997 models: green/white
- 6. 1991-1993 models: black
1994-1997 models: black/white
- 7. 1991-1993 models: red
1994-1997 models: red/white

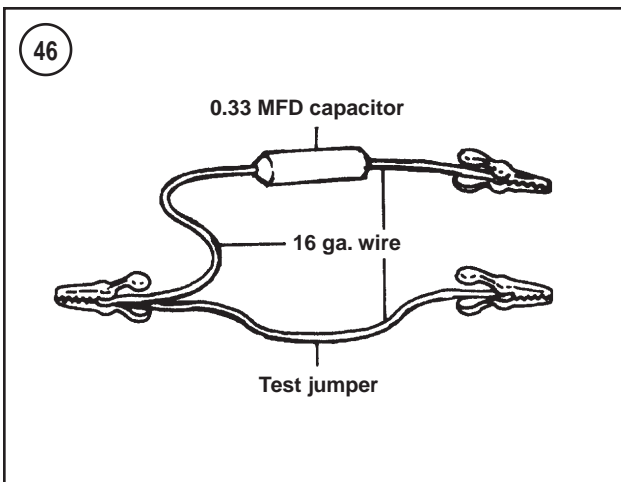
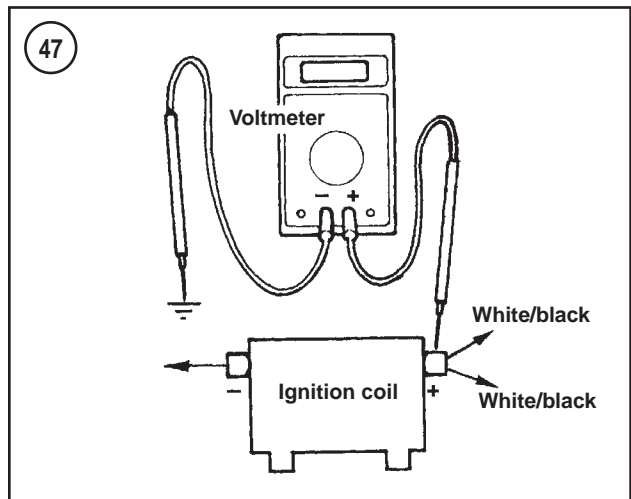
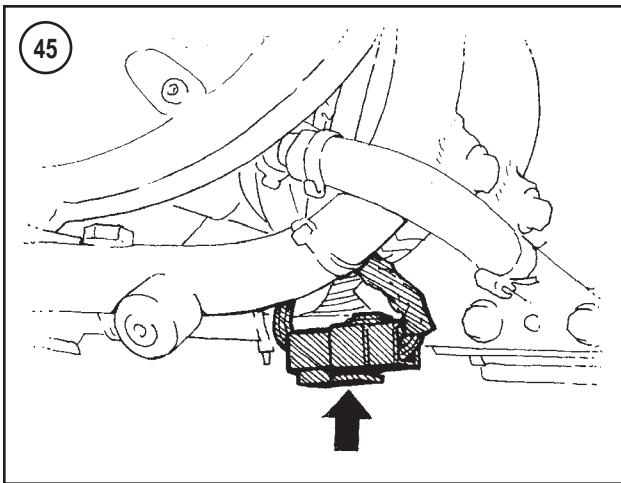
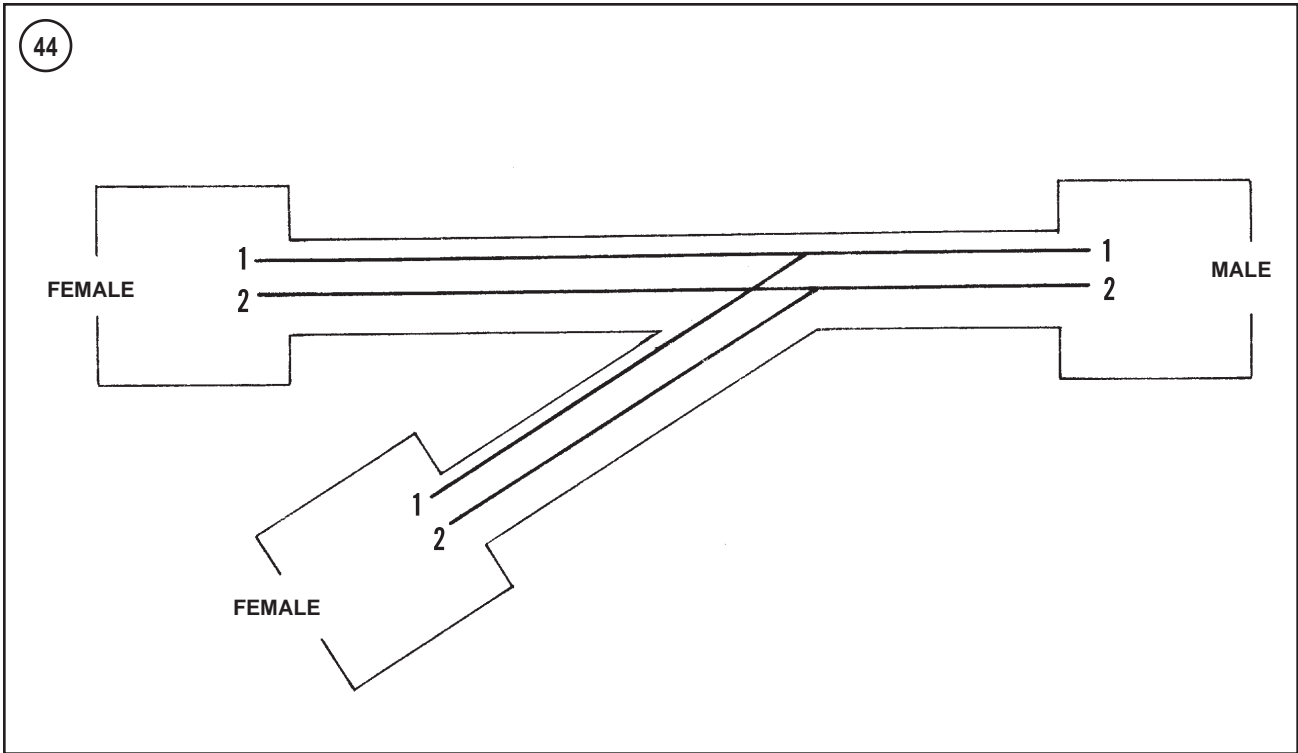

jumper from two lengths of 16-gauge wire, three clips and a 0.33 microfarad (MFD) capacitor (Figure 46). The test jumper must be long enough to reach from the ignition coil to a good engine ground.

3. Perform the following:
 - a. Connect the positive voltmeter lead to the white/black ignition coil wire terminal and the negative voltmeter lead to ground (Figure 47).
 - b. With the ignition switch on. The voltmeter should read 11-13 volts.
 - c. If the voltage is correct, proceed to Step 4.

- d. If the voltage is incorrect, check the ignition system wiring as described in *Ignition Circuit Wiring Check* section in this section.
4. Perform the following:
 - a. Disconnect the pink wire from the ignition coil terminal (**Figure 48**).
 - b. Turn the ignition switch on.
 - c. Connect the negative voltmeter lead to ground. Connect the positive voltmeter lead to the white/black and pink ignition coil terminals separately. The voltmeter should read 12 volts at both terminals.
 - d. If the voltage is correct, proceed to Step 5.
 - e. If the voltage is incorrect, replace the ignition coil.
5. Perform the following:
 - a. Disconnect the pink wire from the ignition coil terminal (**Figure 49**).
 - b. Remove one of the spark plugs. Connect the spark plug wire and connector to the spark plug and ground the spark plug base to the engine cylinder head (**Figure 50**). Position the spark plug so the electrodes are visible.
 - c. Turn the ignition switch on.
 - d. Connect the jumper wire without the capacitor between a good engine ground and the ignition coil pink wire terminal, as shown in **Figure 49**. Momentarily touch the jumper wire with the capacitor to the ignition coil pink wire terminal (**Figure 49**) while observing the spark plug firing tip. The spark plug should fire. Turn the ignition switch off and remove the jumper wire assembly.
 - e. If there is spark, proceed to Step 6.
 - f. If there is no spark, replace the ignition coil.
 - g. Reinstall the spark plug.
6. Perform the following:
 - a. Reconnect the ignition coil pink wire to its terminal on the ignition coil.
 - b. Turn the ignition switch on.
 - c. Disconnect the 6-terminal ignition connector (**Figure 45**).
 - d. At the harness end of the connector, connect the positive voltmeter lead to the ignition module socket No. 1 (white/black wire) and the negative voltmeter lead to the ignition module socket No. 6 (black wire). The voltmeter should read 11-13 volts. Disconnect the voltmeter and turn the ignition switch off.
 - e. If the voltage is correct, proceed to Step 7.
 - f. If the voltage is incorrect, check the continuity between socket No. 1 (white/black wire) on the ignition module connector and the white/black wire at the ignition coil. If there is continuity, repair the open between socket No. 6 (black wire) and ground. If there is no continuity, repair the open in the white/black wire.
7. Perform the following:
 - a. Disconnect the 6-terminal ignition module connector (**Figure 45**).
 - b. Turn the ignition switch on.

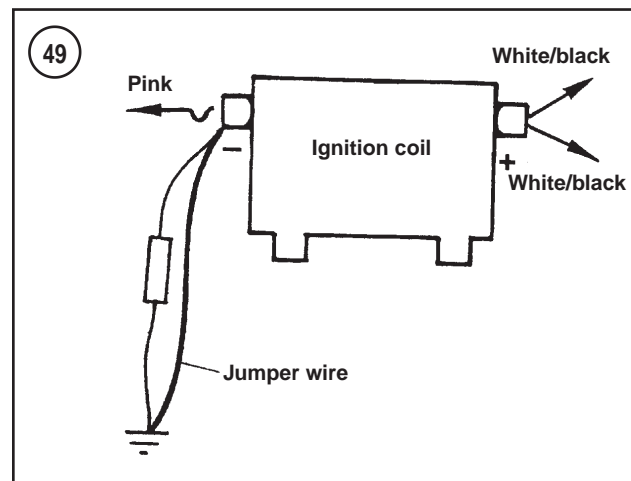
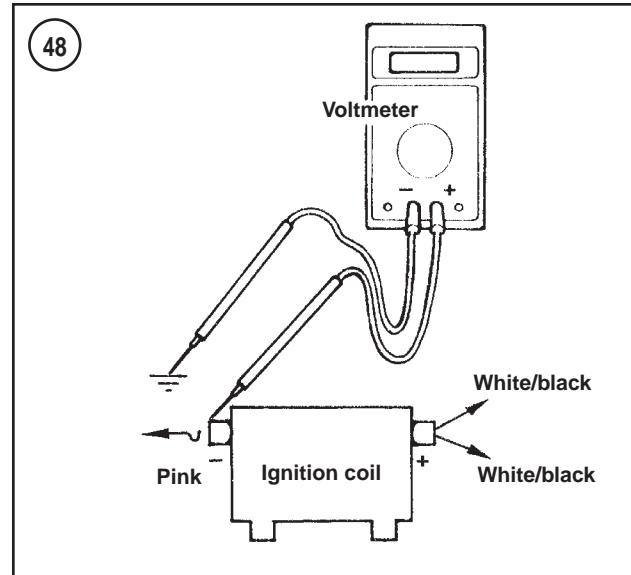

- e. At the harness end of the connector, connect the positive voltmeter lead to socket No. 5 (pink wire) and the black voltmeter lead to socket No. 6 (black wire). The voltmeter should read 11-13 volts. Disconnect the voltmeter and turn the ignition switch off.
- d. If the voltage is correct, proceed to Step 8.
- e. If the voltage is incorrect, check the continuity between socket No. 5 (pink wire) and the pink-wire terminal at the ignition coil. If there is continuity, repair the short to ground on the pink wire. If there is no continuity repair the open circuit in the pink wire.
8. Perform the following:
 - a. Install the test harness between the halves of the ignition coil connector (**Figure 45**), and check the voltage between the green/gray wire and the black wire.
 - b. Turn the ignition switch on.
 - c. Connect the red voltmeter lead to terminal No. 4 on the test harness, and connect the negative voltmeter lead to terminal No. 6 on the test harness. The voltmeter should read 0.6-1.1 volts. Disconnect the voltmeter and turn the ignition switch off.

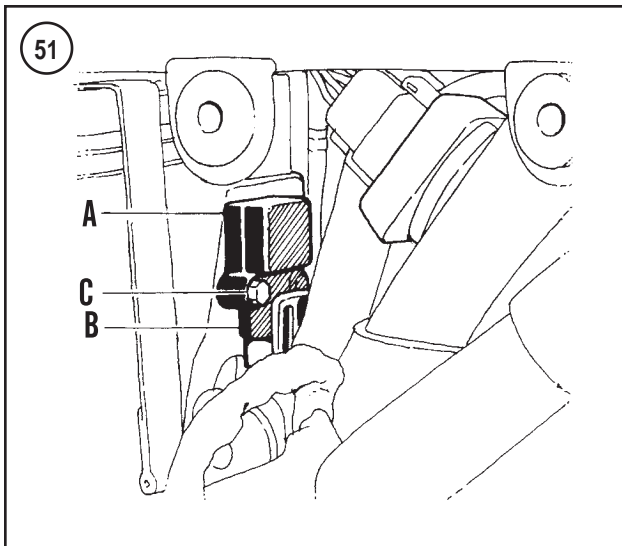

- d. If the voltage is correct, proceed to Step 9.
 - e. If the voltage is incorrect, check the bank angle sensor as described in this section.
9. Perform the following:
 - a. Remove the timing cover.
 - b. Crank the engine and observe the rotor LED. If it is flashing, replace the ignition module. If it is not flashing, proceed to substep c.
 - c. Crank the engine and observe the rotor cup. If the rotor is rotating, replace the ignition module. If it does not rotate, remove the gearcase cover (Chapter Five) and check for an engine mechanical failure.
 10. Install and reconnect all parts removed for this procedure.

Ignition Circuit Wiring Check

1. Check the ignition circuit fuse. If the fuse is burned out, find the source of the problem.
2. Check the voltage at the gray wire at the fuse block.
 - a. Turn the ignition switch on.
 - b. Connect the positive voltmeter lead to the gray-wire terminal and connect the negative voltmeter lead to a

good ground. The voltmeter should read battery voltage. Disconnect the voltmeter and turn the ignition switch off.

- c. If the voltage is correct, perform Step 3.
 - d. If the voltage is incorrect, check for an open circuit between the battery, 30-amp circuit breaker, ignition switch, and fuse block. Make the necessary repairs.
3. Check for voltage at the right control switch connector.
 - a. Disconnect the right control connector from the switch (Chapter Twelve).
 - b. Turn the ignition switch on.
 - c. On the harness side of the connector, attach the positive voltmeter lead to pin No. 3 (gray wire) and connect the negative voltmeter lead to a good ground. The voltmeter should read battery voltage. Disconnect the voltmeter and turn the ignition switch off.
 - d. If voltage is correct, perform step 4.
 - e. If voltage is incorrect, repair the open in the gray wire between the connector and fuse block.
 4. Perform the following:
 - a. Connect the right control switch connector to its mate.
 - b. Turn the ignition switch on.
 - c. Turn the engine stop switch to the run position.
 - d. Connect the positive voltmeter lead to pin No. 5 (white/black wire) on the harness side of the connector, and connect the negative voltmeter lead to a good ground. The voltmeter should read battery voltage. Disconnect the voltmeter and turn the ignition switch off.
 - e. If voltage is correct, repair the open in the white/black wire between the ignition coil and right-hand switch connector (No. 22).
 - f. If voltage is incorrect, check the engine stop switch and its wiring. Repair or replace the faulty component as necessary.

Bank Angle Sensor Check

1. Inspect the bank angle sensor (A, **Figure 51**). Note the following:
 - a. Make sure the sensor connection is secure.
 - b. Make sure the sensor is mounted correctly. It must be secure against the battery case and sit upright on the case.
 - c. Make sure there is no ferrous metal within 1/4 inch of the side, face or top of the sensor.

CAUTION

To avoid damaging the terminals in Step 2, remove the bank angle sensor before disconnecting the connector.

2. Remove the bank angle sensor (A, **Figure 51**) and disconnect the sensor connector (B).
3. Turn the ignition on.
4. Measure the voltage between socket A (green/gray wire) on the sensor connector and socket B (black wire) of the

connector. Disconnect the voltmeter and turn the ignition switch off. Note the following:

- a. If the voltage was zero volts, perform Step 5.
 - b. If the voltage was 3.0-3.5 volts, perform Step 6.
 - c. If the voltage measured 11-13 volts, repair the short in the green/gray wire.
5. Perform the following:
- a. Disconnect the bank angle sensor connector.
 - b. Disconnect the 6-terminal ignition module connector (**Figure 45**).
 - c. Check the continuity between socket A (green/gray wire) on the sensor connector and socket No. 4 (light green/gray wire) on the harness end of the ignition module connector. If there is continuity, perform substep d. If there is no continuity, repair the open circuit in the green/gray wire.
 - d. Check the continuity between socket B (black wire) on the sensor connector and ground. If there is continuity, perform substep e. If there is no continuity, repair the open circuit in the black wire.
 - e. Check the continuity between socket A (green/gray wire) on the sensor connector and ground. If continuity is present, repair the short to ground in the green/gray wire. If continuity is not present, perform substep f.
 - f. Inspect the harness for damage; repair as necessary. If the harness is not damaged, replace the ignition module.
6. Perform the following:
- a. Turn the ignition on.
 - b. Measure the voltage between socket B (black wire) on the sensor connector and socket C (gray wire) on the connector. If the voltmeter reads 11-13 volts, perform Step c. If the voltage is not 11-13 volts, repair the open circuit in the gray wire between the sensor connector and the ignition fuse.
 - c. Make sure that the sensor connection and/or its mounting location/position were not the source of the malfunction. See Step 1.
 - d. Replace the sensor, if it fails any of these steps.

IGNITION SYSTEM (1998-2003 1200S MODELS)

Review *Precautions and Troubleshooting Preparation in Ignition System (1986-1997 Models)* in this chapter.

Refer to the wiring diagrams at the end of this manual.

Tools

Troubleshooting the ignition system requires a breakout box (part No. HD-42682). The breakout box connects inline between the ignition module and the wiring harness. It provides test points for checking a live circuit.

If a breakout box is not available, fabricate two test harnesses as shown in **Figure 44**. Make each test harness from 24 lengths of 18-gauge wire, a male Deutsch connector

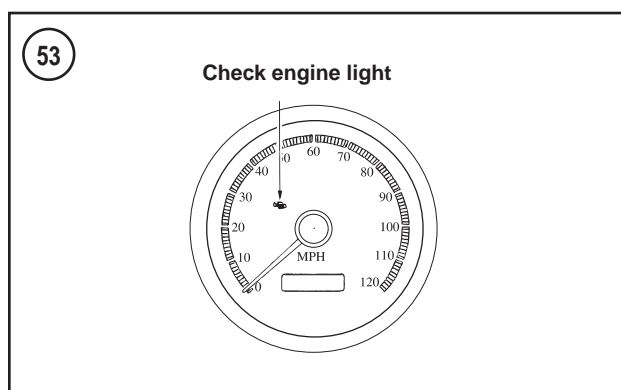
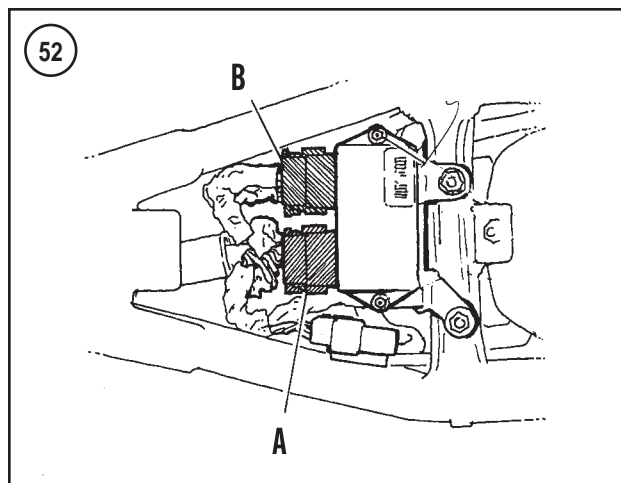

(12-pin) and two female Deutsch connectors (12-socket). Wire the No. 1 pin on the male connector to the No. 1 socket on each female connector, No. 2 pin to No. 2 socket, etc.

When the test harness is required, test points are identified as terminals on the black- or gray-colored harness, (terminal No. 2 on the black test harness, for example). Consequently, take care to identify one harness as black and the other as gray. Use black connector housings on one harness and gray housings on the other or wrap the wires of one test harness with black electrical tape and wrap the wires of the second harness with gray tape.

To connect the test harnesses, disconnect the black (connector No. 10) and gray (connector No. 11) ignition-module connectors from the ignition module. Connect the gray test harness in-line between the ignition module and gray ignition-module connector (A, **Figure 52**). Connect the black test harness in-line between the ignition-module and black ignition-module connector (B, **Figure 52**). Probe the second female connector on each respective test harness at the indicated test point.

Troubleshooting the ignition system also requires a harness test kit (part No. HD-41404). Different-sized terminals are used in the connectors on a Sportster. This kit is equipped with different sized probes for checking the voltage and resistance of the various-sized terminals without damaging the wire insulation.

54

CODE DESCRIPTION TROUBLESHOOTING CHART

| Code | Component/circuit | Action |
|------|-------------------------------|--------------------------|
| 12 | MAP sensor | Figure 68 |
| 16 | Battery voltage | Figure 69 |
| 24 | Front coil | Figure 70 |
| 25 | Rear coil | Figure 70 |
| 35 | Tachometer | |
| | 1998 models | Figure 71 |
| | 1999-2003 models | Figure 72 |
| 41 | Cam position sensor | Figure 73 |
| 44 | Bank angle sensor | Figure 74 |
| 52 | 1998 models: RAM/ROM failure | Replace ignition module* |
| 52 | 1999-2003 models: RAM failure | Replace ignition module* |
| 53 | 1999-2003 models: ROM failure | Replace ignition module* |
| 54 | EE PROM failure | Replace ignition module* |

*Before replacing the ignition module confirm it is defective by taking it to a dealership. Further testing requires the scanalyzer.

55

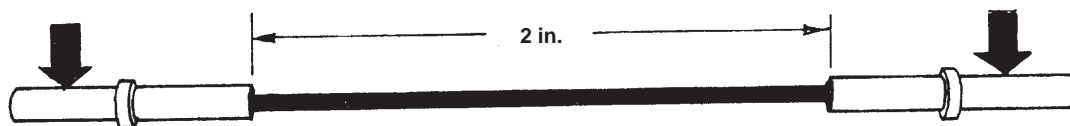

Diagnostic Trouble Codes

The 1200S models have an on-board diagnostic system to help troubleshoot the ignition system. During operation, the system identifies faults and stores this information as a two-digit diagnostic trouble code.

If a trouble code has been set, the check engine light (**Figure 53**) will come on. During normal operation, the check engine light illuminates for approximately four seconds when the ignition is turned to on. The check-engine light then turns off and remains off. If a diagnostic trouble code has been set, the check-engine light turns on for four seconds, turns off, and then turns back on for eight seconds or it remains on beyond the eight-second period.

Trouble codes can be retrieved with the Scanalyzer (Part No. HD-41325) or by counting the number of times the check-engine light flashes. If using the Scanalyzer for code retrieval, follow the manufacturer's instructions. Code(s) can also be retrieved by performing the procedure described in this section. Use the chart in **Figure 54** to identify the defective system and to determine a course of action.

Retrieving codes

Diagnostic trouble codes are displayed as a series of flashes at the check-engine light. To retrieve any stored diagnostic trouble codes, a jumper made of 18-gauge wire

and two Deutsch sockets (part No. 72191-94), as shown in **Figure 55**, is required.

To retrieve the diagnostic trouble codes without the Scanalyzer, perform the following:

1. Remove the left side cover from the motorcycle.
2. Remove the data link connector (**Figure 56**) from its holder on the back of the side cover.
3. Remove the protective cover (A, **Figure 57**) from the data link connector (B), and connect the jumper to pins No. 1 and No. 2 on the data link connector.
4. Turn the ignition switch to ignition. After approximately eight seconds, the system enters the diagnostic mode.
 - a. The diagnostic mode begins with a ready signal, which is a series of rapid flashes of approximately three per second. The ready signal indicates that the system is ready to flash a diagnostic trouble code.
 - b. This is followed by a two-second pause.
 - c. The system then flashes the first digit of the stored diagnostic trouble code. The check-engine light will illuminate for one second and then turn off for one second. Count the number of flashes, and record this number.
 - d. The system will pause for two seconds, and then flash the second digit of the diagnostic trouble code. Count the number of flashes, and record this number.

- e. The system will pause for two seconds, and then flash the ready signal, which indicates it is ready to flash the next code.
 - f. The system will pause for two seconds, and then flash the first digit of the next diagnostic trouble code.
5. The system displays codes, sequentially, one-at-a-time, until each diagnostic trouble code has been displayed. The system then repeats. The check-engine light will continue to flash stored codes until the jumper wire is disconnected. When the codes repeat, this indicates that all the stored codes have been displayed.
 6. Find the diagnostic trouble code in **Figure 54**, and perform the procedure indicated in the chart. If multiple codes have been set, troubleshoot the lowest numbered code first. The source of subsequent codes may be the same malfunction that has caused the first.
 7. Reinstall the protective cover onto the data link connector, and fit the connector into its holder in the back of the left side cover.
 8. Align the side cover pins with the grommets in the frame, and push the side cover into place.

Clearing codes

The system will retain the trouble codes until they are cleared with the Scanalyzer or until the motorcycle has been run through 50 start-run cycles. After a fault has been corrected, the memory is erased automatically after 50 start-run cycles if the fault does not reoccur. A start-run cycle occurs when the engine is started and run for at least 30 seconds before being turned off.

Ignition Control Module Replacement

Before replacing the ignition module, confirm that the ignition module is defective by having a dealership test it. There are several ignition-module tests that can only be performed with a Scanalyzer (part no. HD-41325).

Troubleshooting Tests

1. Review *Precautions and Troubleshooting Preparations in Ignition System (1986-1997 Models)* in this chapter. Refer to the wiring diagrams at the end of this manual.
2. Perform the spark test as described in *Starting The Engine* in this chapter.
 - a. If there is spark, the problem is not in the ignition system. Check the fuel system.
 - b. If there is no spark or only a weak one, recheck the ignition with new spark plugs. If the condition remains the same with new spark plugs and if all external wiring connections are good, the problem is most likely in the ignition system; perform the procedure in **Figure 58**. Follow the procedure in the chart until the problem is resolved.

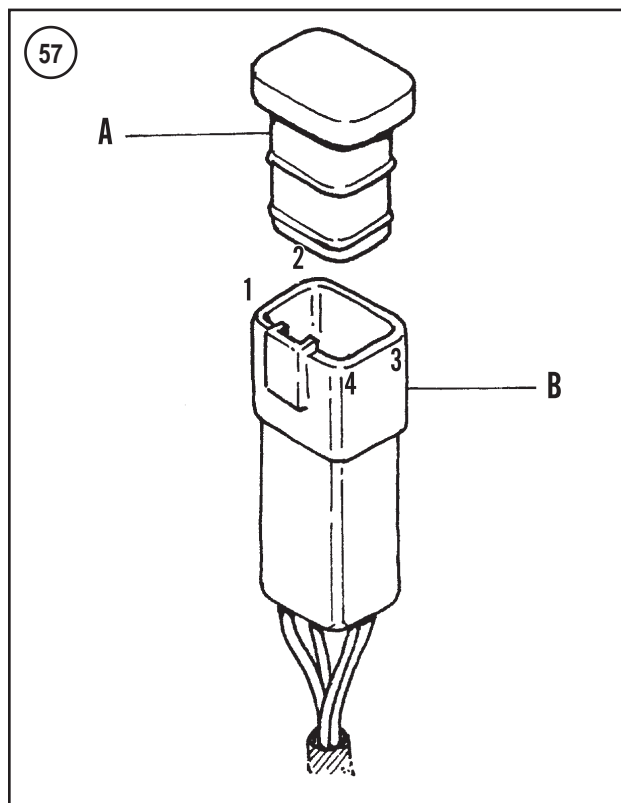
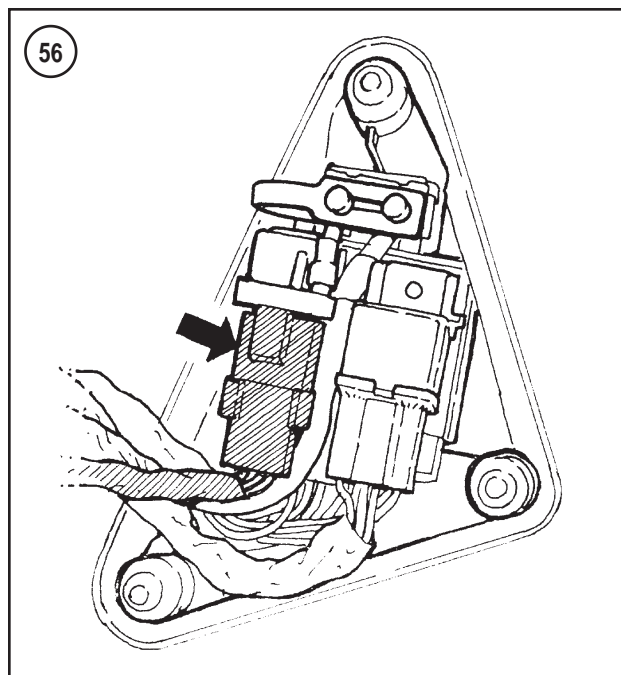

Wiggle Test

Several troubleshooting procedures advise performing a wiggle test. Perform the following when so advised:

1. Connect the meter as instructed in the flow chart.
2. Wiggle the wiring harness and observe the meter.
3. Large resistance fluctuations indicate the presence of an intermittent short in the harness. Check the wiring harness.

58

RETRIEVING DIAGNOSTIC CODES (1998-2003 1200S MODELS)

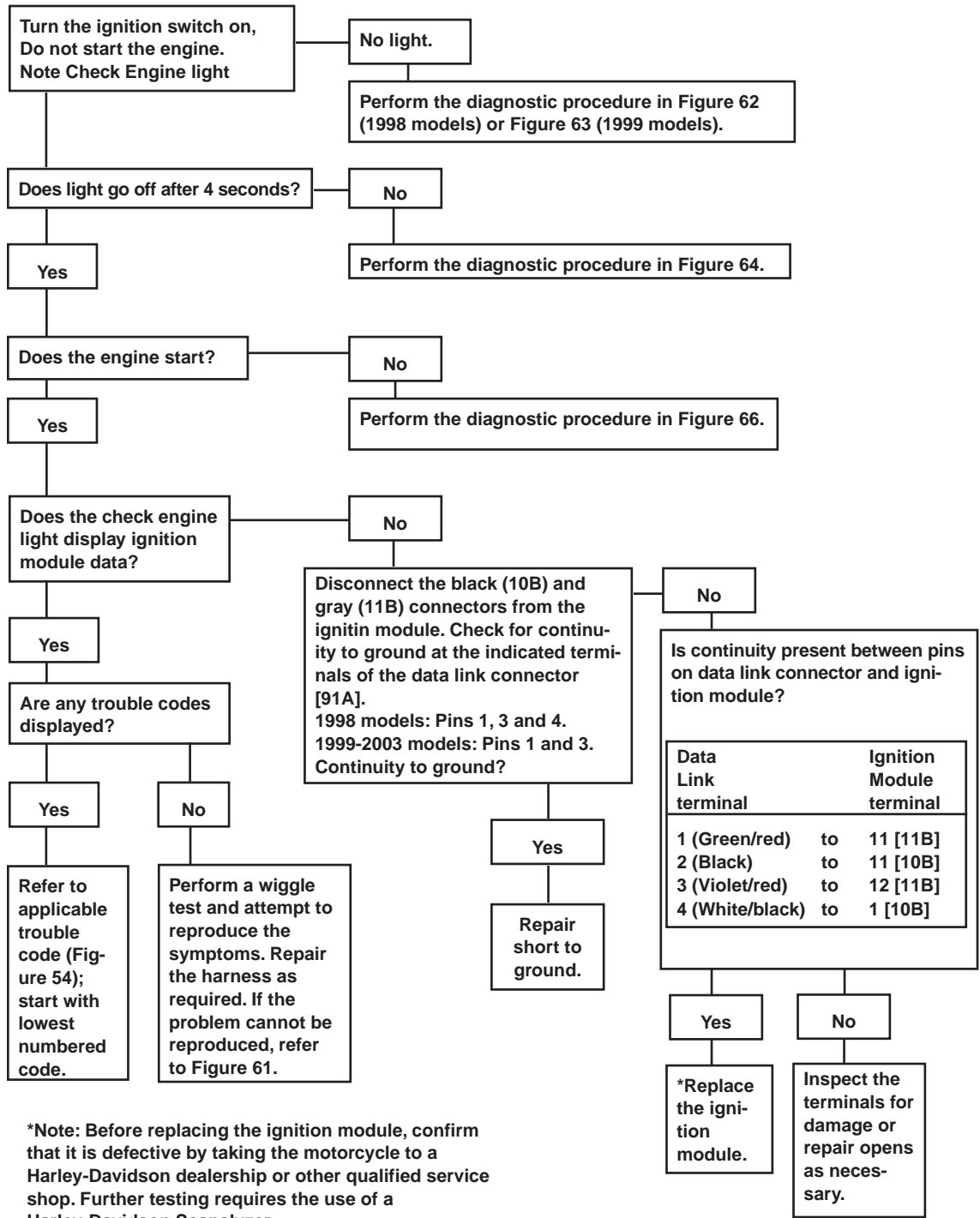

Spark Plug Cable Resistance Test

1. Disconnect the spark plug cable from the spark plug and from the ignition coil.
2. Connect the probes of an ohmmeter to the cable terminals.
3. Replace the spark plug cable if the resistance is not within the specification in **Table 2**.
4. Repeat this procedure for the remaining cables.

Ignition Coil Test (1998-2003 1200S Models)

1. Disconnect the spark plug wires (A, **Figure 59**) from the coil towers on the coil.
2. Disconnect the ignition coil connector (B, **Figure 59**) from the ignition-coil primary terminals.
3. Measure the resistance in the primary windings.
 - a. Measure the resistance between primary terminals A and B on the ignition coil.
 - b. Measure the resistance between primary terminals B and C on the coil.
 - c. Compare the readings to the specification in **Table 2**.
4. Measure the resistance of the secondary windings.
 - a. Measure the resistance between both secondary terminals (No. 1 and 4) on the front coil (**Figure 60**).
 - b. Measure the resistance between both secondary terminals (No. 2 and 3) on the rear coil (**Figure 60**).
 - c. Compare the readings to the specification in **Table 2**.
5. Replace the ignition coil if any reading is not within specification.

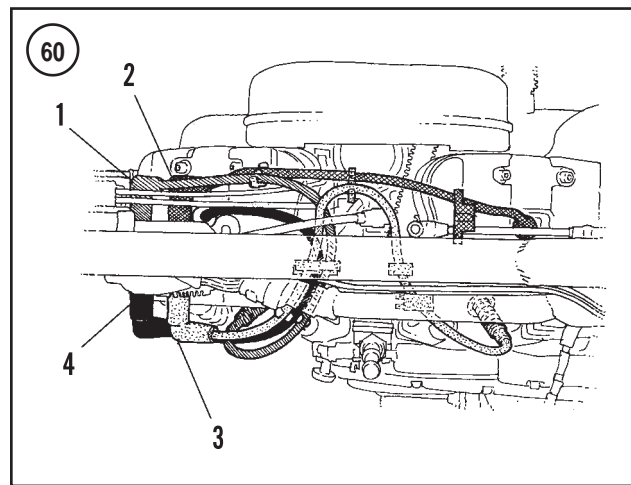
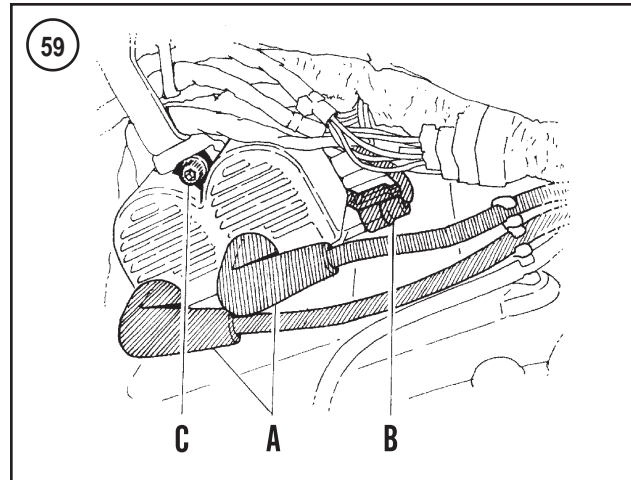

Troubleshooting Symptoms

Refer to **Figures 61-74** for various symptoms and testing procedures.

FUEL SYSTEM

Begin fuel system troubleshooting with the fuel tank and work through the system, reserving the carburetor as the final point. Do not assume the carburetor is the problem. Unnecessary carburetor adjustment can compound the problem.

Identifying Carburetor Conditions

Refer to the following conditions to identify whether the engine is running lean or rich.

Rich

1. Fouled spark plugs.
2. Engine misfires and runs rough under load.
3. Excessive exhaust smoke as the throttle is increased.

4. An extreme rich condition causes a choked, or dull sound from the exhaust and an inability to clear the exhaust with the throttle held wide open.

Lean

1. Blistered or very white spark plug electrodes.
2. Engine overheats.
3. Slow acceleration and engine power is reduced.
4. Flat spots on acceleration that are similar in feel to when the engine starts to run out of gas.
5. Engine speed fluctuates at full throttle.

Troubleshooting

Isolate fuel system problems to the fuel tank, fuel shutoff valve and filter, fuel hoses, external fuel filter (if used) or carburetor. In the following procedures, it is assumed that the ignition system is working properly.

Refer to **Figure 75** or **Figure 76** and the following sections for possible causes of fuel system problems.

61

SYMPTOMS

| Symptom | Possible cause | Action |
|---|---|---|
| Hard to Start | Battery discharged | Troubleshoot the charging system as described in this chapter |
| | Spark plugs Ignition coil Plug wires Valve sticking Water or dirt in the fuel system | Perform the procedure in Figure 67 Perform the procedure in Figure 67 Perform the procedure in Figure 67 Refer to the Chapter Four Drain the fuel system and refill with fresh fuel |
| Engine hesitates, stumbles, surges, misfires or is sluggish | Manifold leak | Spray water around the intake manifold seals while the engine idles. If idle speed changes, replace the seals. |
| | MAP sensor is not operating properly | Check the vacuum hose connection and perform the procedure in Figure 68 |
| | Water or dirt in the fuel system | Drain the fuel system and refill with fresh fuel |
| | Spark plug EVAP hose disconnected from carburetor (California models) Throttle plates not opening fully | Perform the procedure in Figure 68 Reconnect Adjust the throttle cable as described in Chapter Three |
| Engine exhaust emits black smoke or spark plugs are fouled | Clogged air filter MAP sensor is not operating properly | Replace the air filter (Chapter Three) Check the vacuum hose connection and perform the procedure in Figure 68 |

2

Fuel level system

The fuel level system is shown in **Figure 77** or **Figure 78**. Proper carburetor operation depends on a constant and correct carburetor fuel level. As fuel is drawn from the float bowl during engine operation, the float level in the bowl drops. As the float drops, the fuel valve moves from its seat and allows fuel to flow through the seat into the float bowl. Fuel entering the float bowl causes the float to rise and push against the fuel valve. When the fuel level reaches a predetermined level, the fuel valve is pushed against the seat to prevent the float bowl from overflowing.

If the fuel valve fails to close, the engine will run rich or flood with fuel. Symptoms of this problem are rough running, excessive black smoke and poor acceleration. This condition will sometimes clear up when the engine is run at wide-open throttle and the fuel is being drawn into the engine before the float bowl can overflow. However, as the engine speed is reduced, the rich running condition returns.

Several things can cause fuel overflow. In most instances, a small piece of dirt is trapped between the fuel valve and seat, or the float level is incorrect. If fuel is flowing out of the overflow tube connected to the bottom of the float bowl, the fuel valve inside the carburetor is being held open. First check the position of the fuel shutoff valve lever (A, **Figure 79**). Turn the fuel shutoff valve lever off. Then lightly tap on the carburetor float bowl and turn the fuel shutoff valve lever on. If the fuel flow stops running out of

the overflow tube, whatever was holding the fuel valve off of its seat has been dislodged. If fuel continues to flow from the overflow tube, remove and service the carburetor. See Chapter Ten or Chapter Eleven.

NOTE

Fuel will not flow from the vacuum-operated fuel shutoff valve on 1995-2003 models until the engine is running.

Starting enrichment (choke) system

A cold engine requires a rich mixture to start and run properly. On all models, a cable-actuated starter enrichment valve is used for cold starting.

If the engine is difficult to start when cold, check the starting enrichment (choke) cable adjustment described in Chapter Three.

Accelerator pump system

During sudden acceleration, the diaphragm type accelerator pump system (**Figure 80** or **Figure 81**) provides additional fuel to the engine. Without this system, the carburetor would not be able to provide a sufficient amount of fuel.

The system consists of a spring-loaded neoprene diaphragm that is compressed by the pump lever during sudden

62

NO CHECK ENGINE LAMP WITH KEY ON (1998 MODELS)

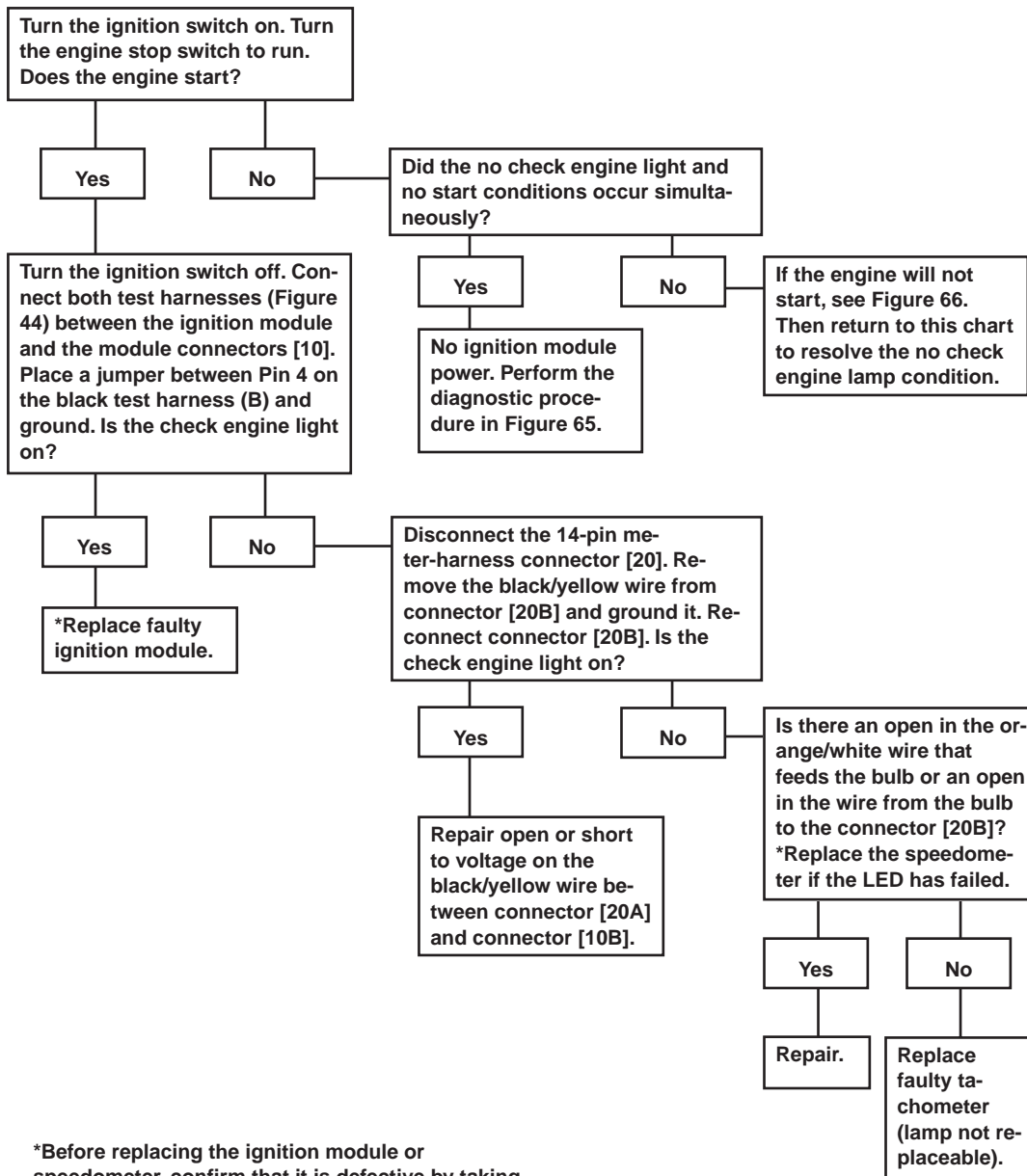

*Before replacing the ignition module or speedometer, confirm that it is defective by taking the motorcycle to a dealership. Further testing requires the use of a Scanalyzer.

CHECK ENGINE LIGHT CIRCUIT (1998 MODELS)

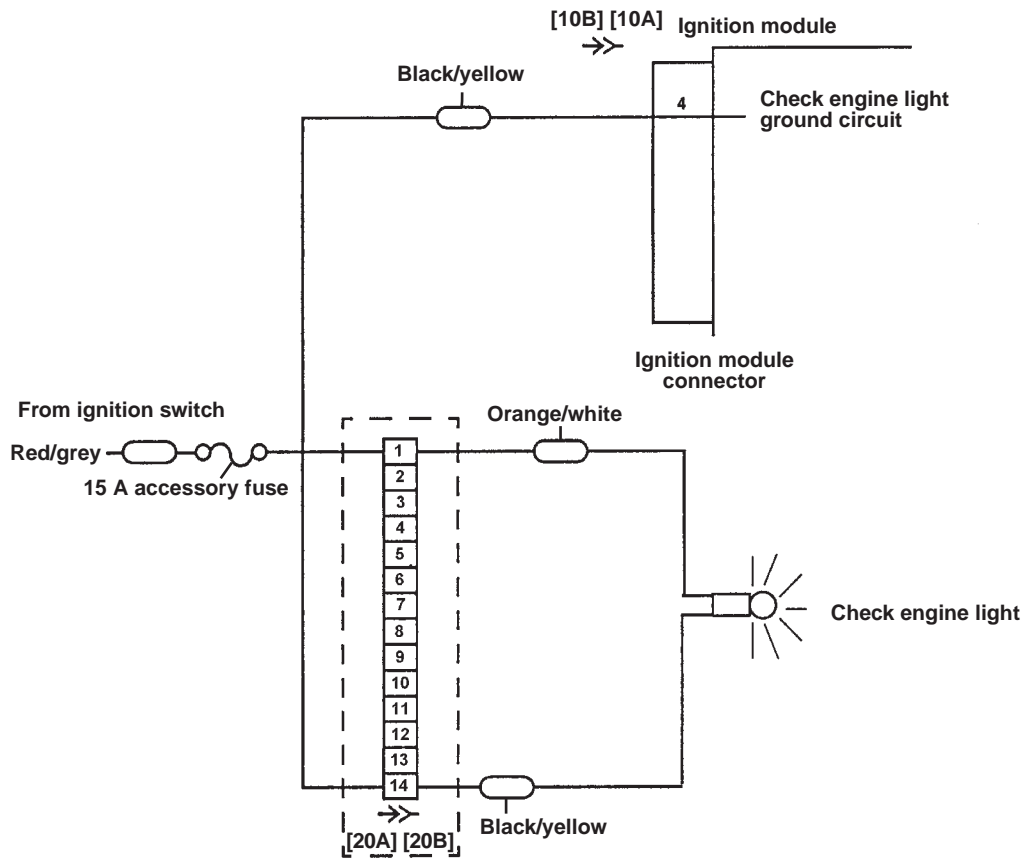

63

NO CHECK ENGINE LIGHT WITH KEY ON (1999-2003 MODELS)

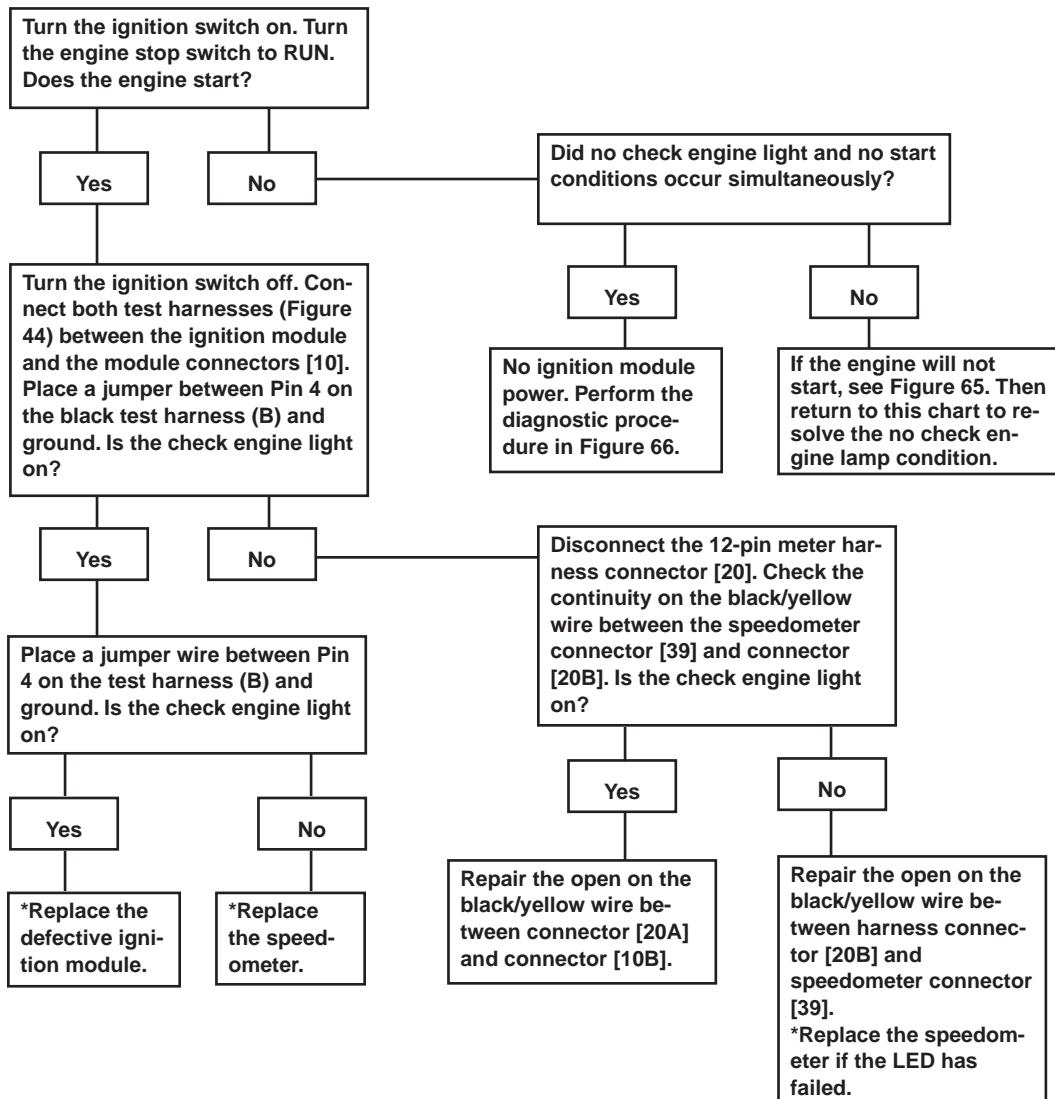

*Before replacing the ignition module or speedometer, confirm that it is defective by taking the motorcycle to a dealership. Further testing requires the Scanalyzer.

CHECK ENGINE LIGHT CIRCUIT (1999-2003 MODELS)

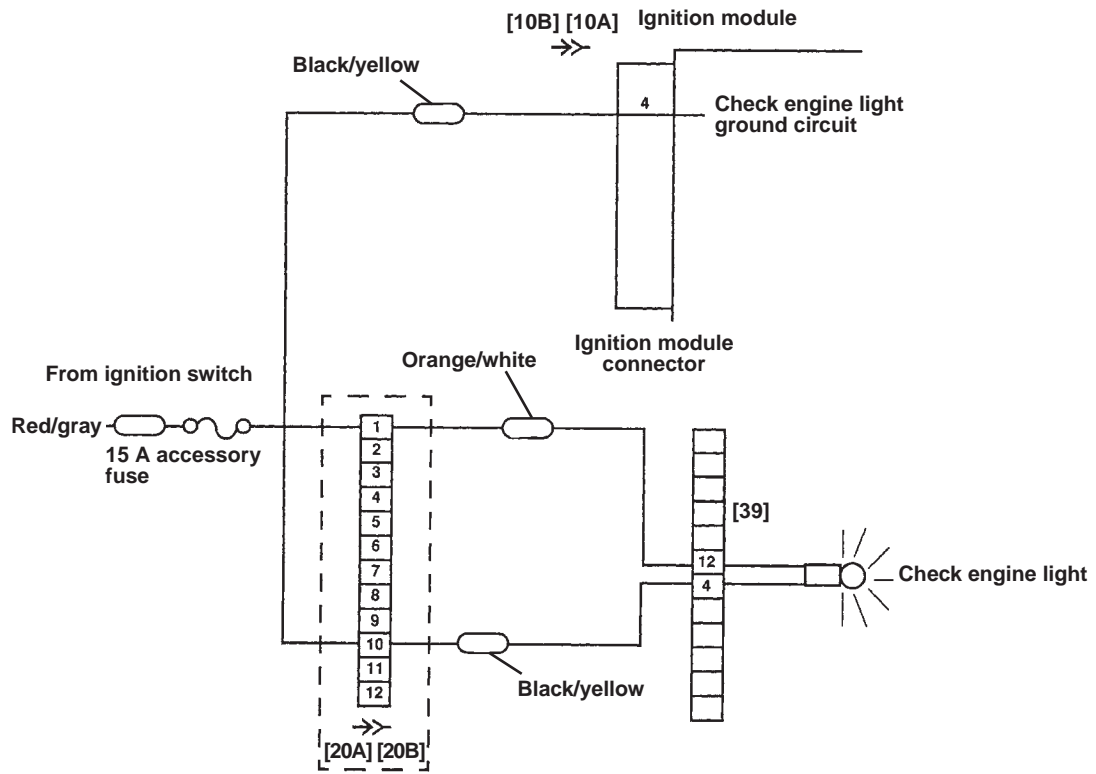

64

CHECK ENGINE LIGHT CONTINUOUSLY ON

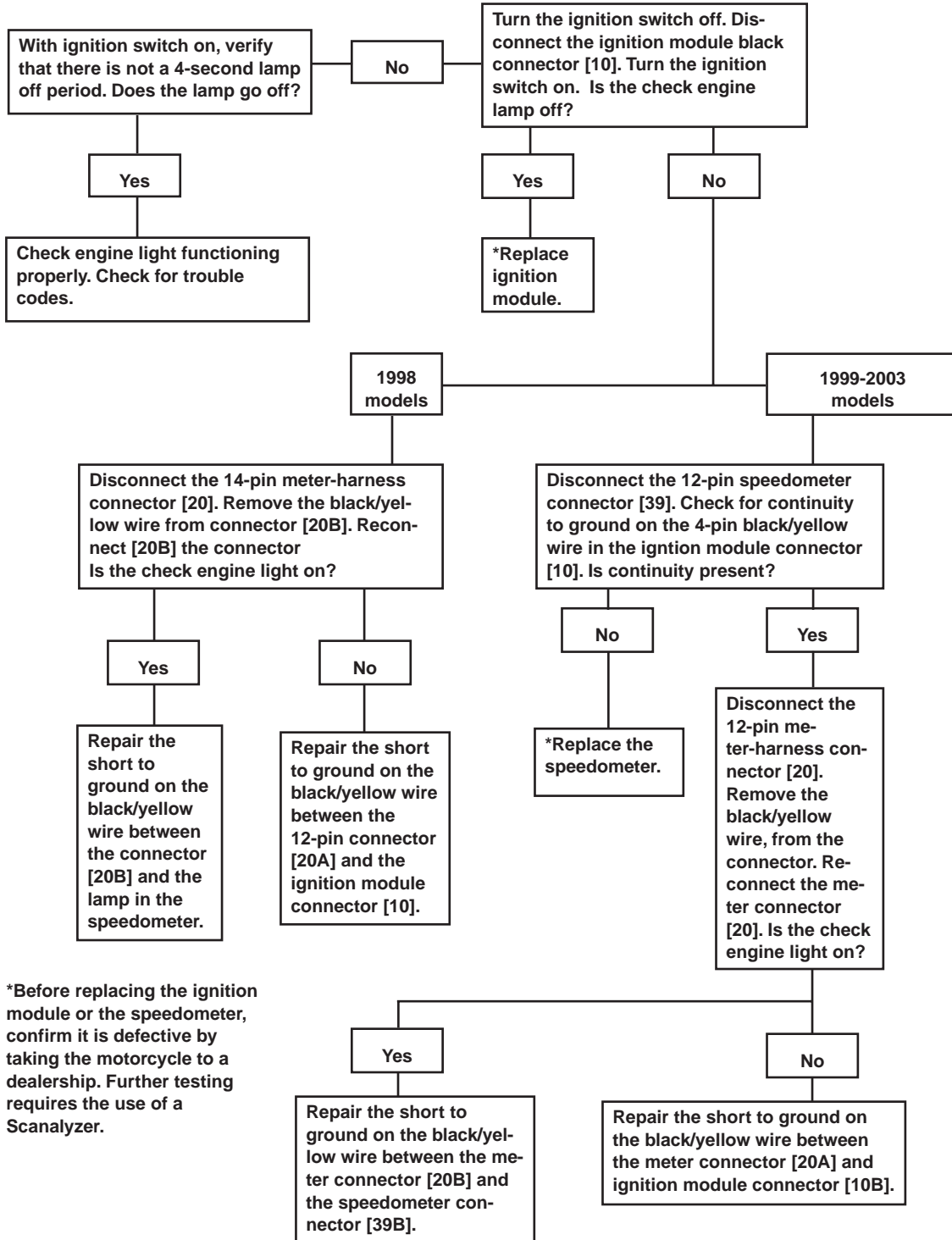

*Before replacing the ignition module or the speedometer, confirm it is defective by taking the motorcycle to a dealership. Further testing requires the use of a Scanalyzer.

65

NO SPARK, NO CHECK ENGINE LIGHT WITH KEY ON

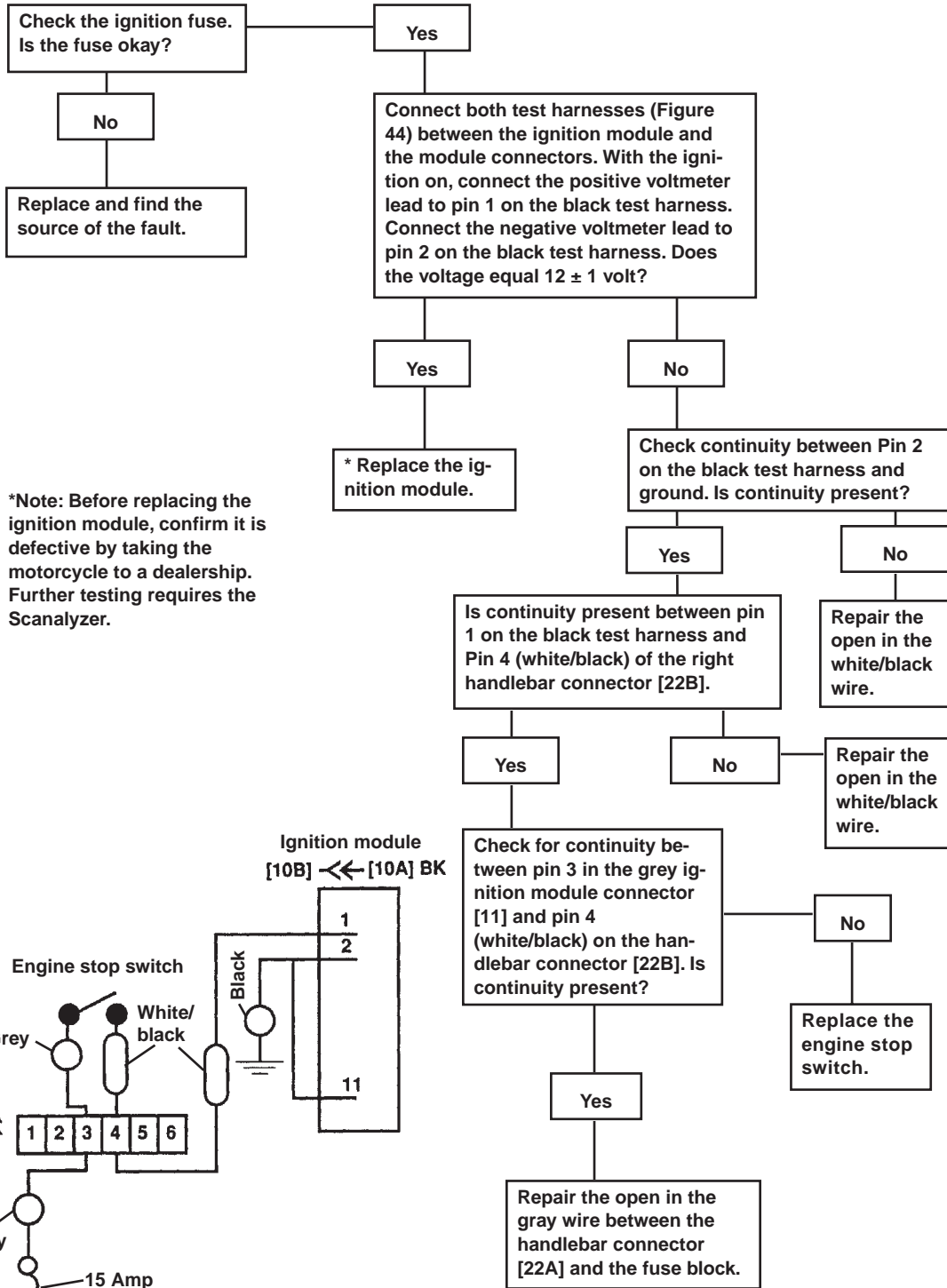

*Note: Before replacing the ignition module, confirm it is defective by taking the motorcycle to a dealership. Further testing requires the Scanalyzer.

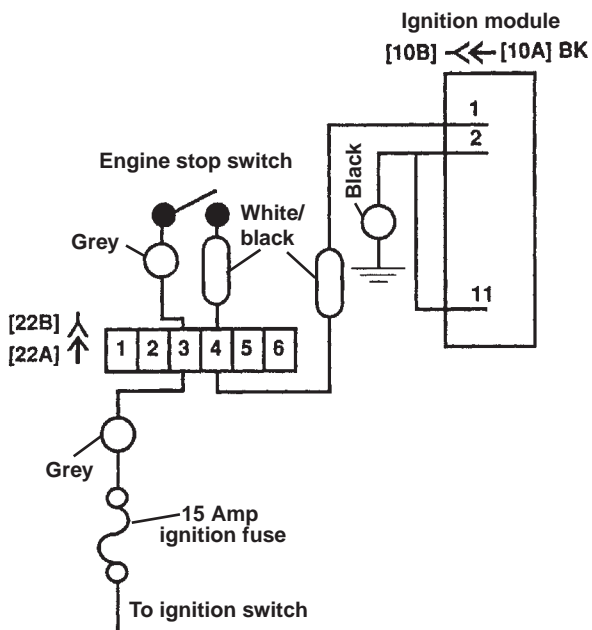

66

ENGINE CRANKS BUT WILL NOT START

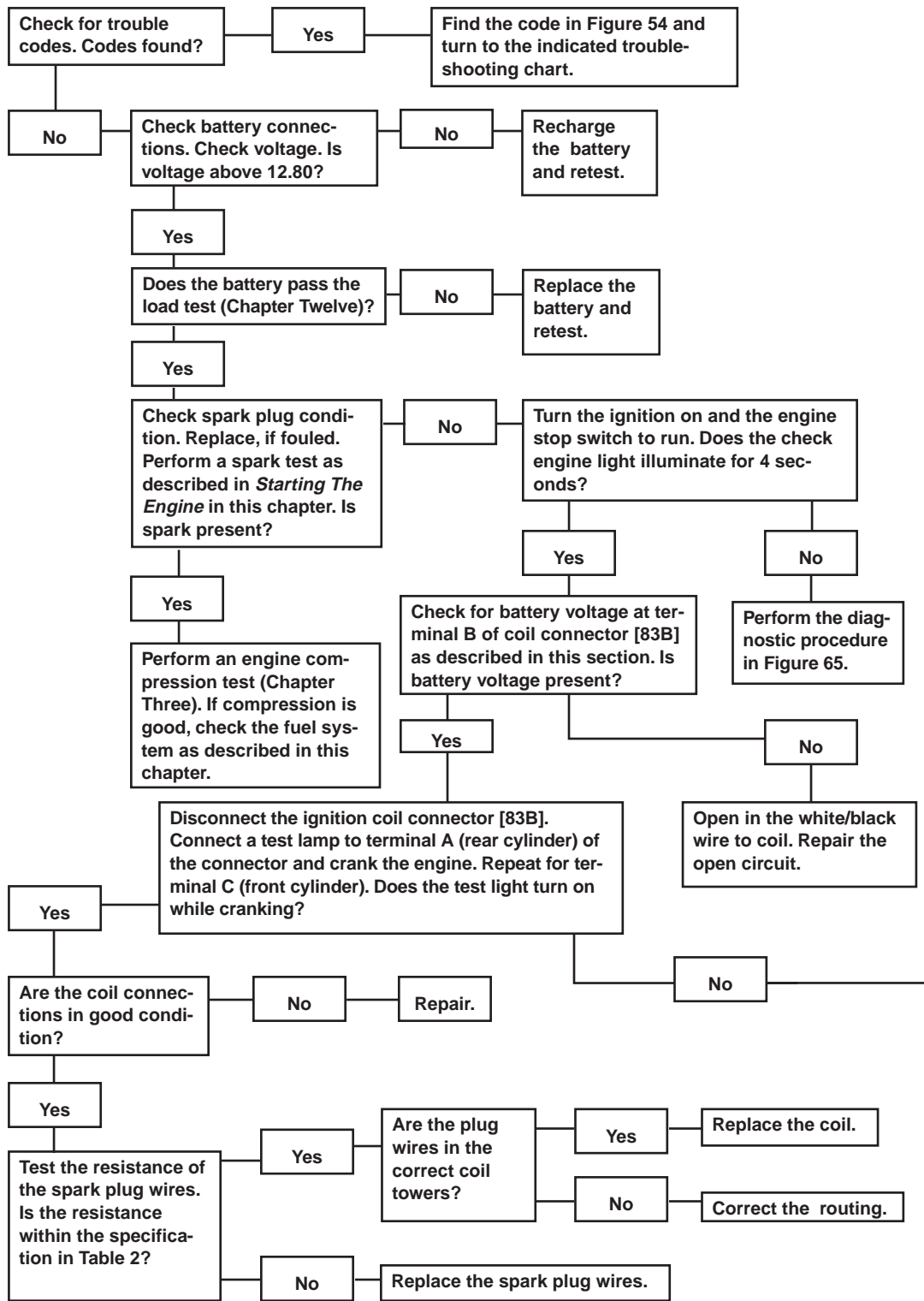

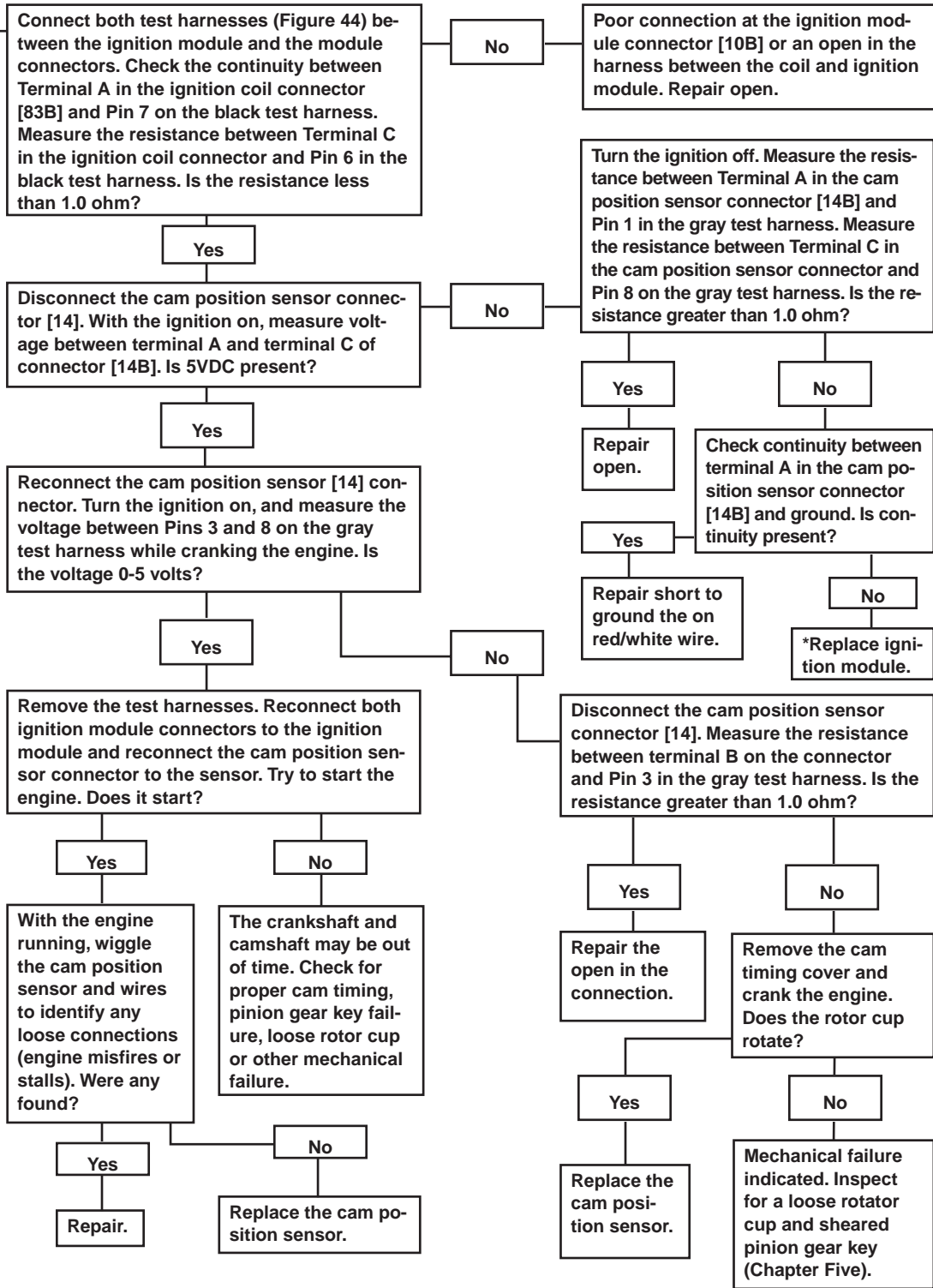

*Before replacing the ignition module, confirm it is defective by taking it to a dealership. Further testing requires the Scanalyzer.

67

MISFIRE

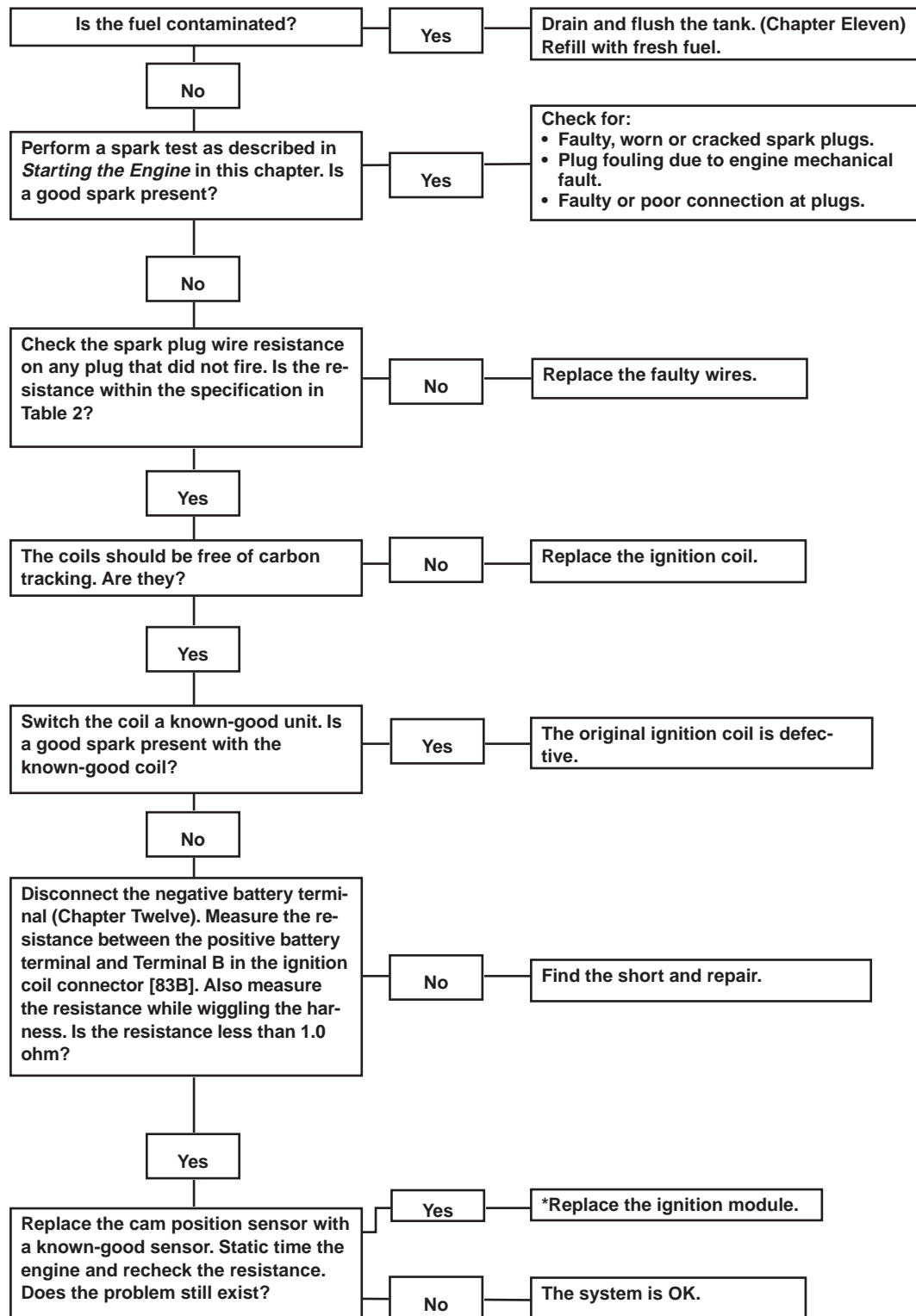

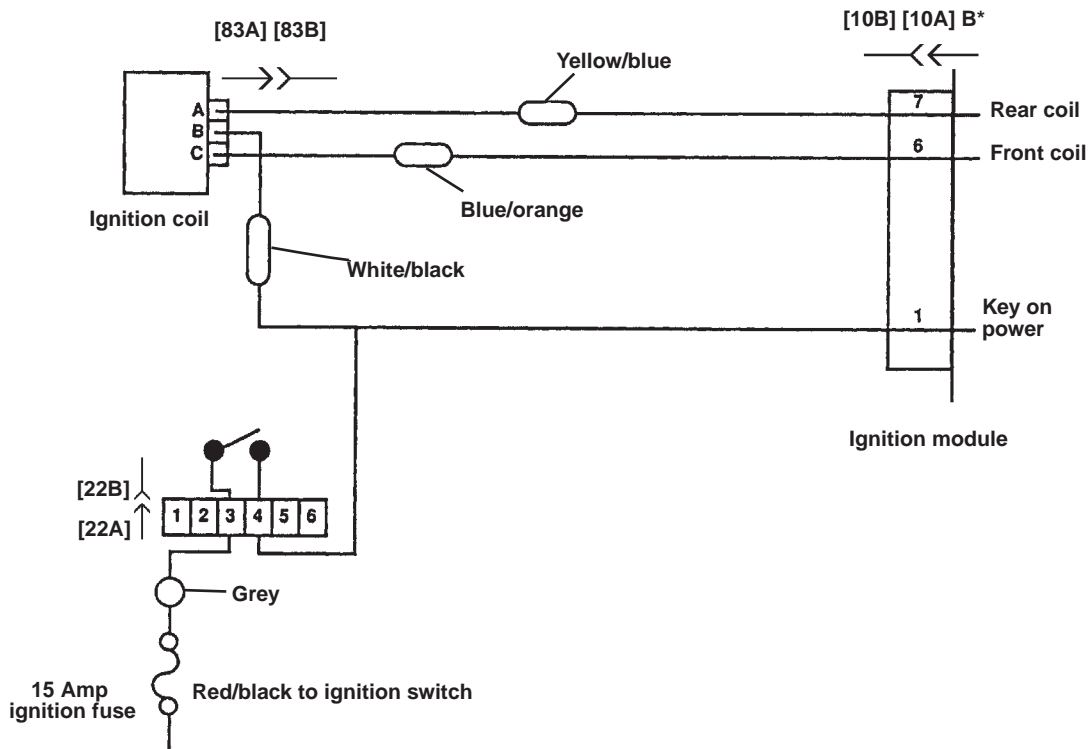

***Note:** Before replacing the ignition module, confirm it is defective by taking the motorcycle to a dealership. Further testing requires the Scanalyzer.

68

MAP SENSOR

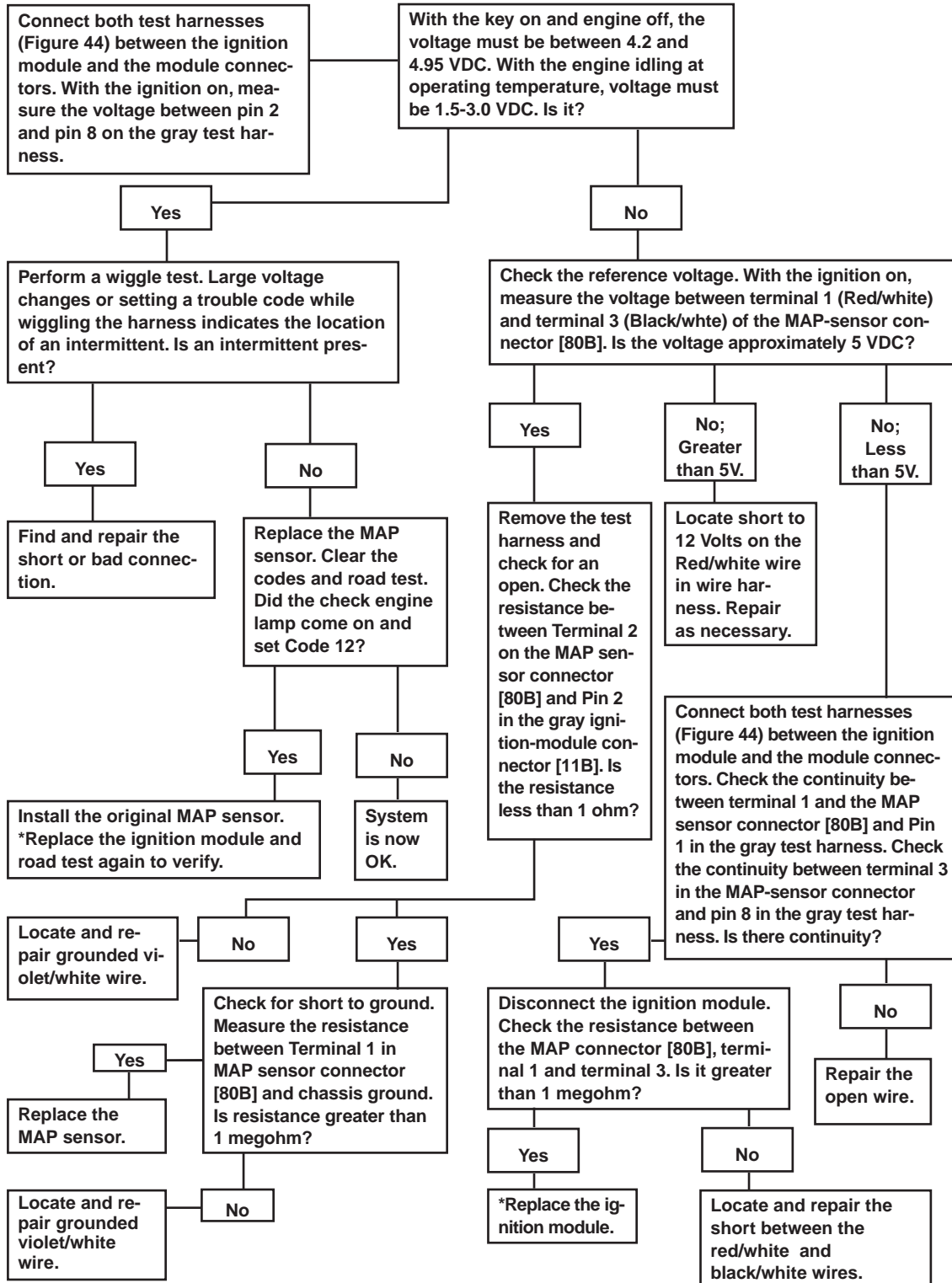

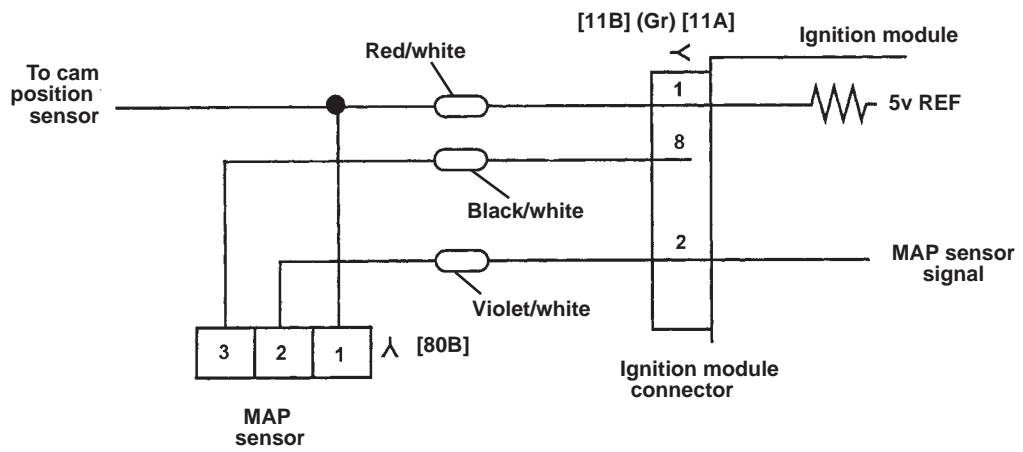

*Before replacing the ignition module, confirm it is defective by taking the motorcycle to a dealership. Further testing requires the Scanalyzer.

69

BATTERY VOLTAGE

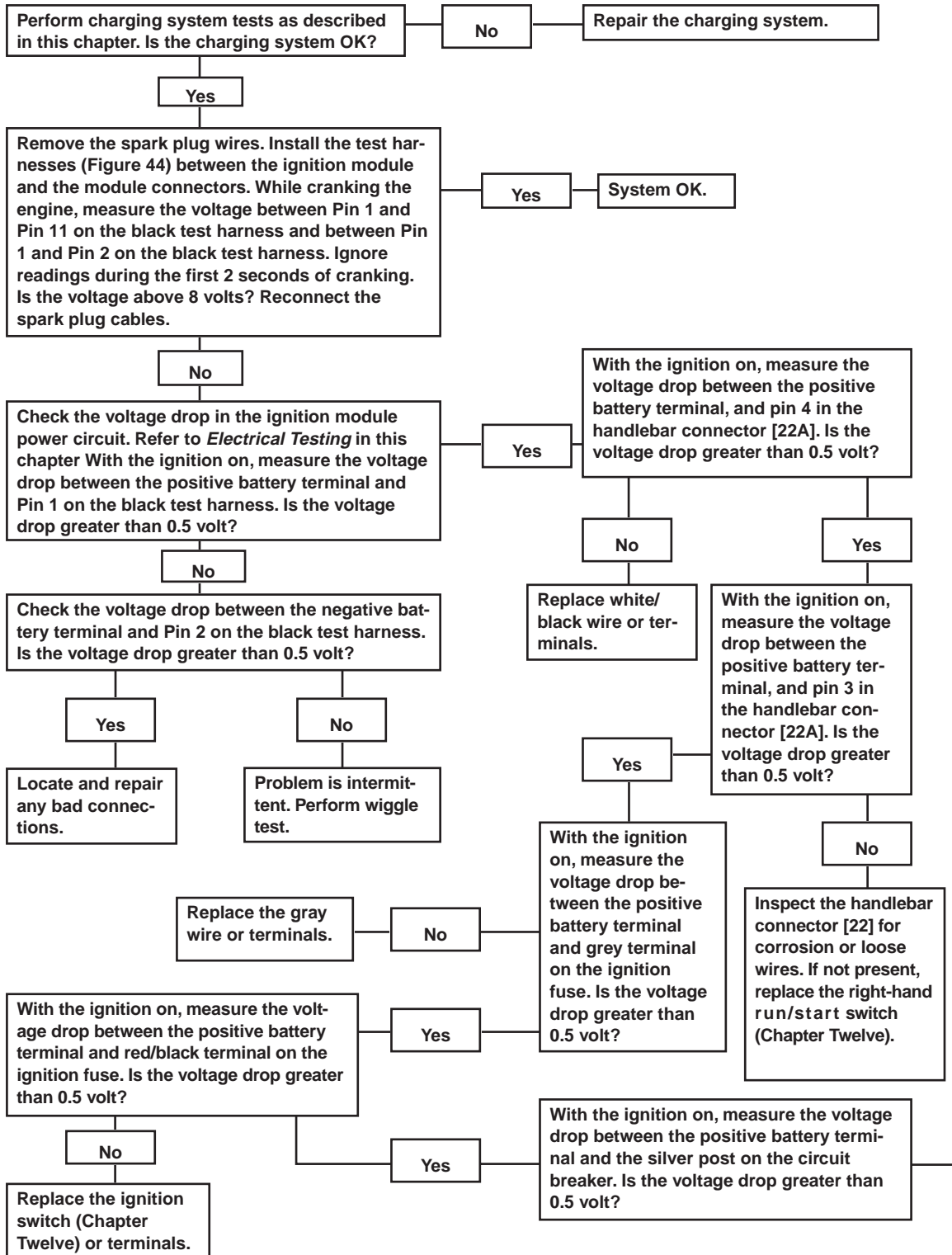

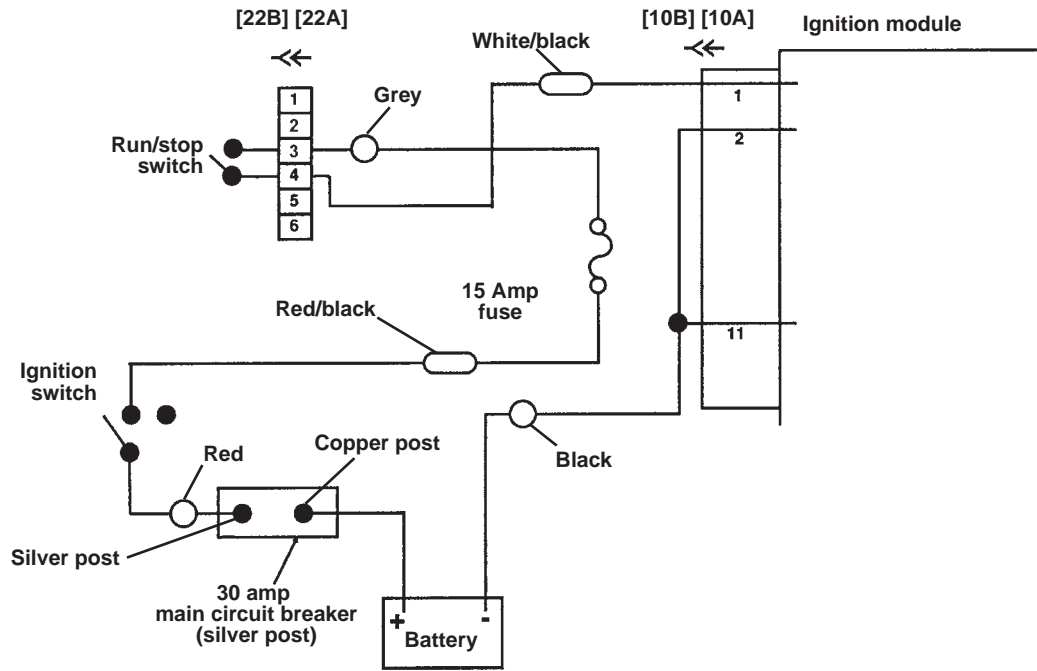
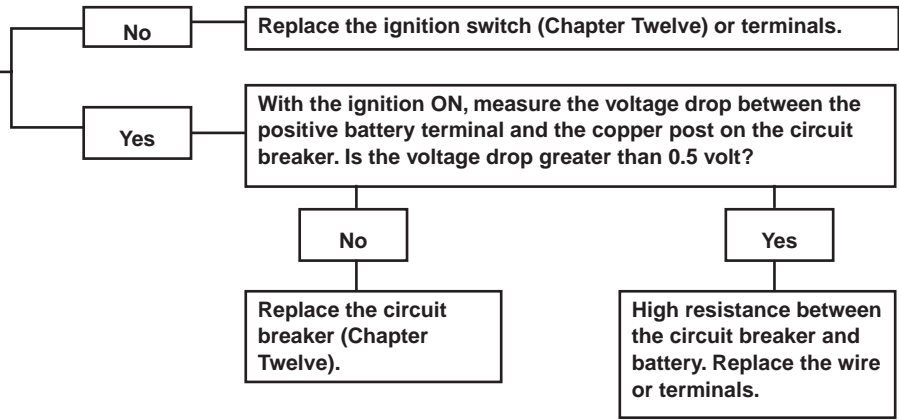

70

IGNITION COIL

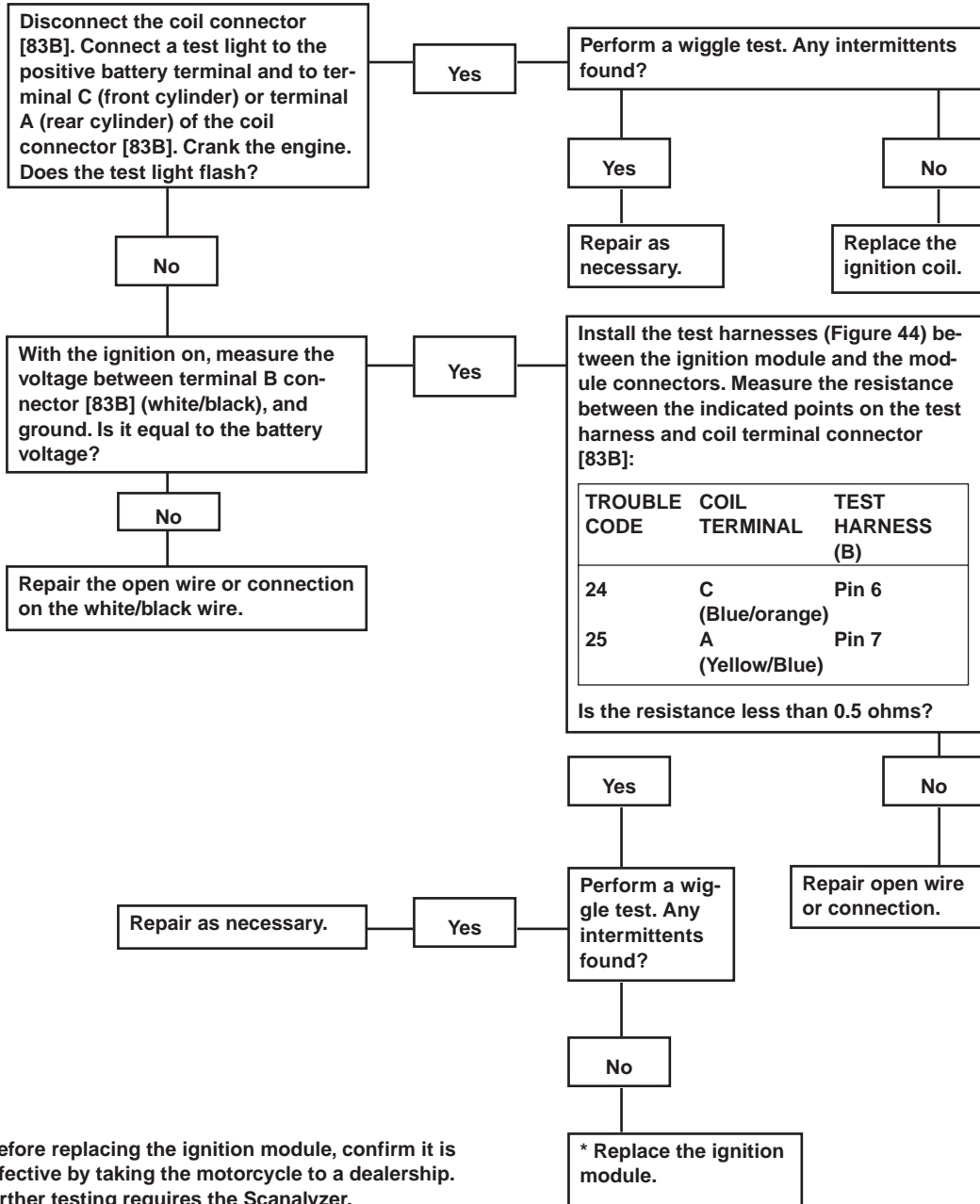

*Before replacing the ignition module, confirm it is defective by taking the motorcycle to a dealership. Further testing requires the Scanalyzer.

71

TACHOMETER (1998 1200S MODELS)

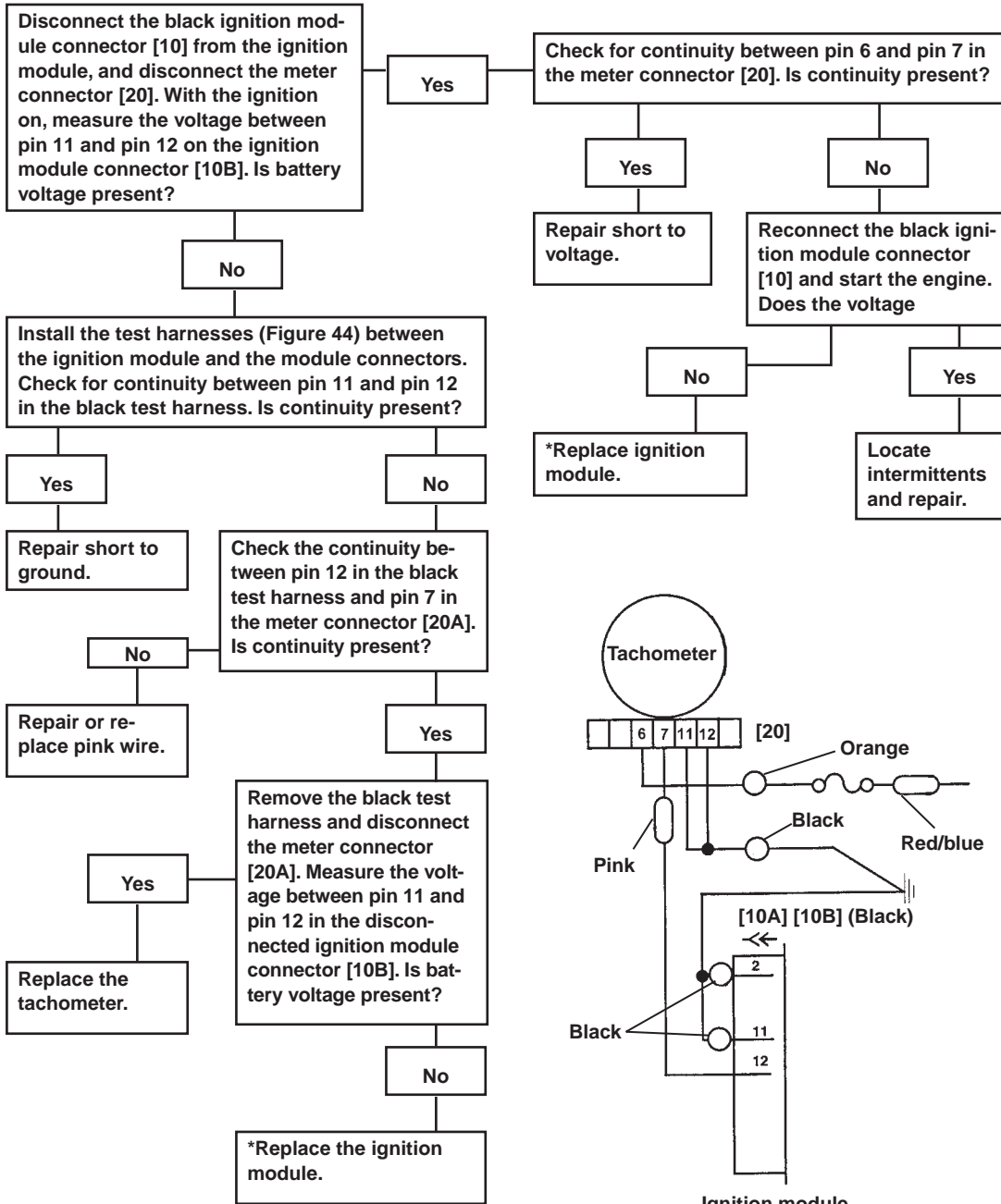

*Before replacing the ignition module, confirm it is defective by taking the motorcycle to a dealership. Further testing requires the Scanalyzer.

72

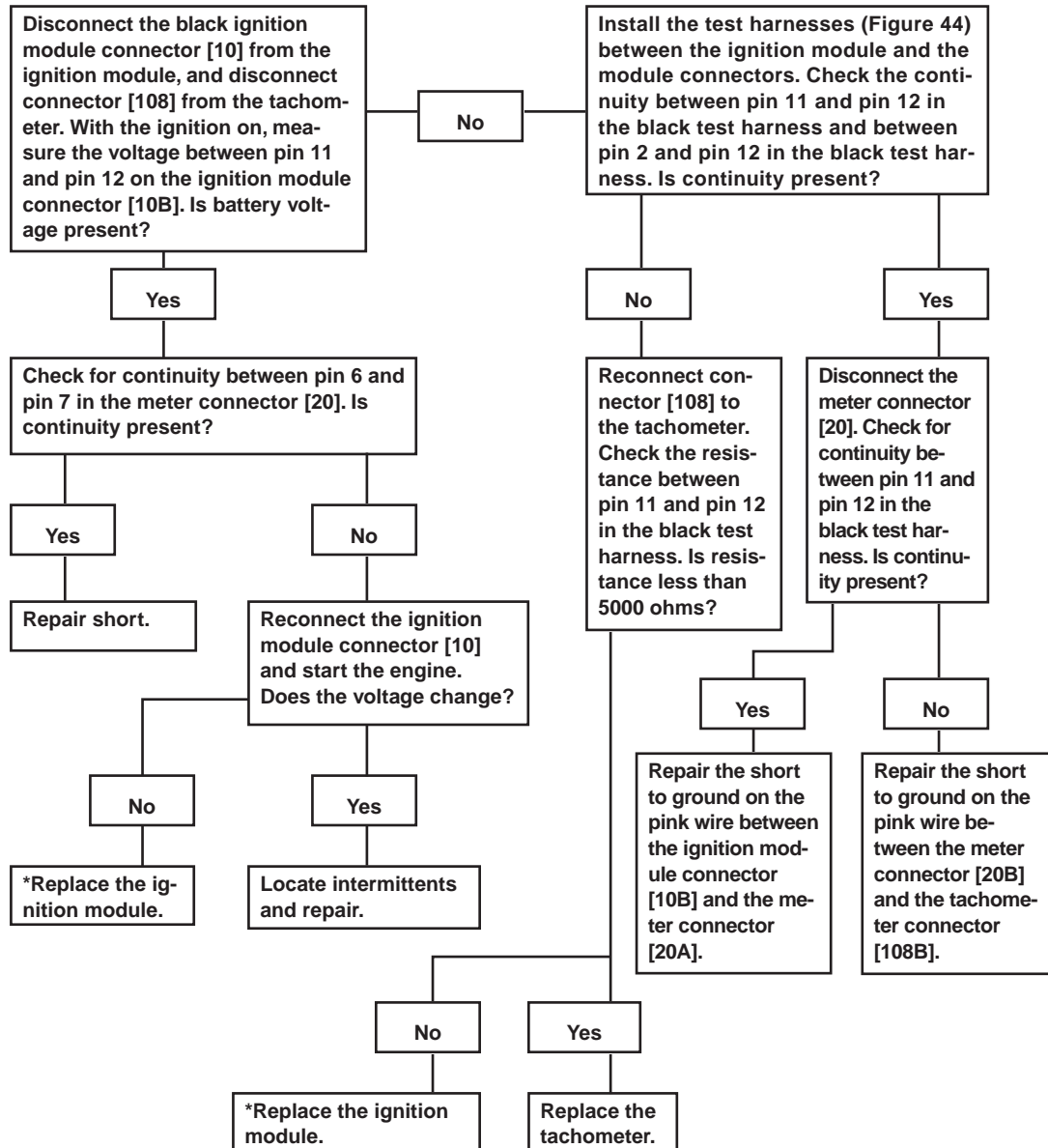
TACHOMETER (1999-2003 1200S MODELS)

*Before replacing the ignition module, confirm it is defective by taking the motorcycle to a dealership. Further testing requires the Scanalyzer.

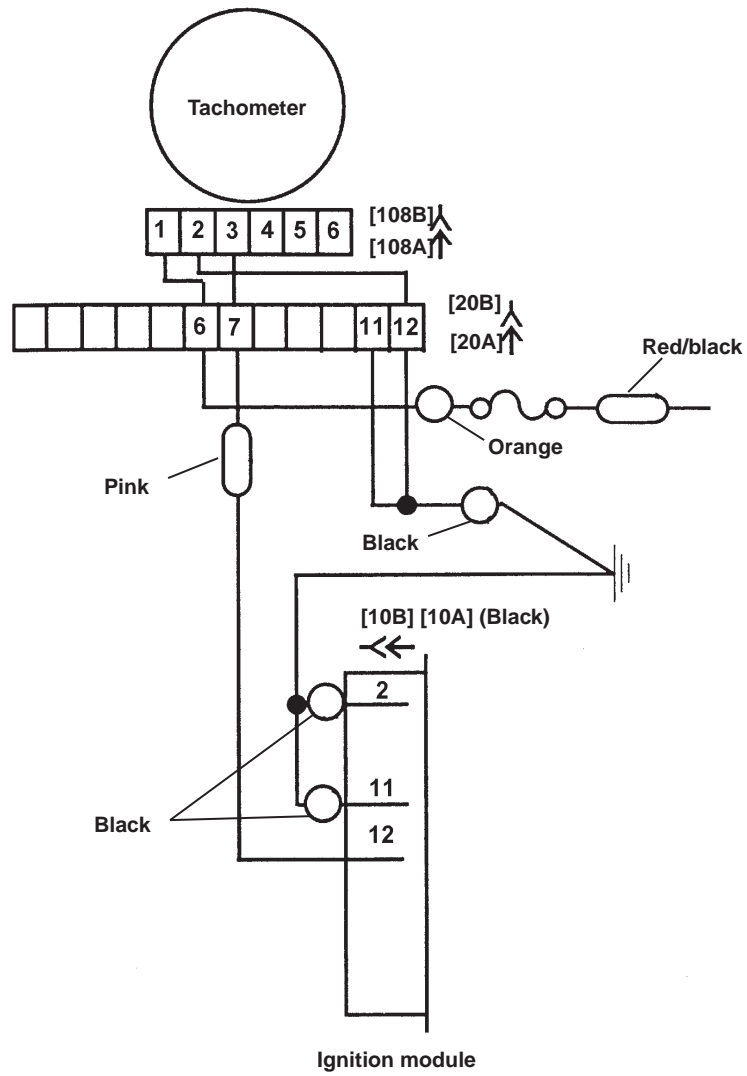

73

CAM POSITION SENSOR

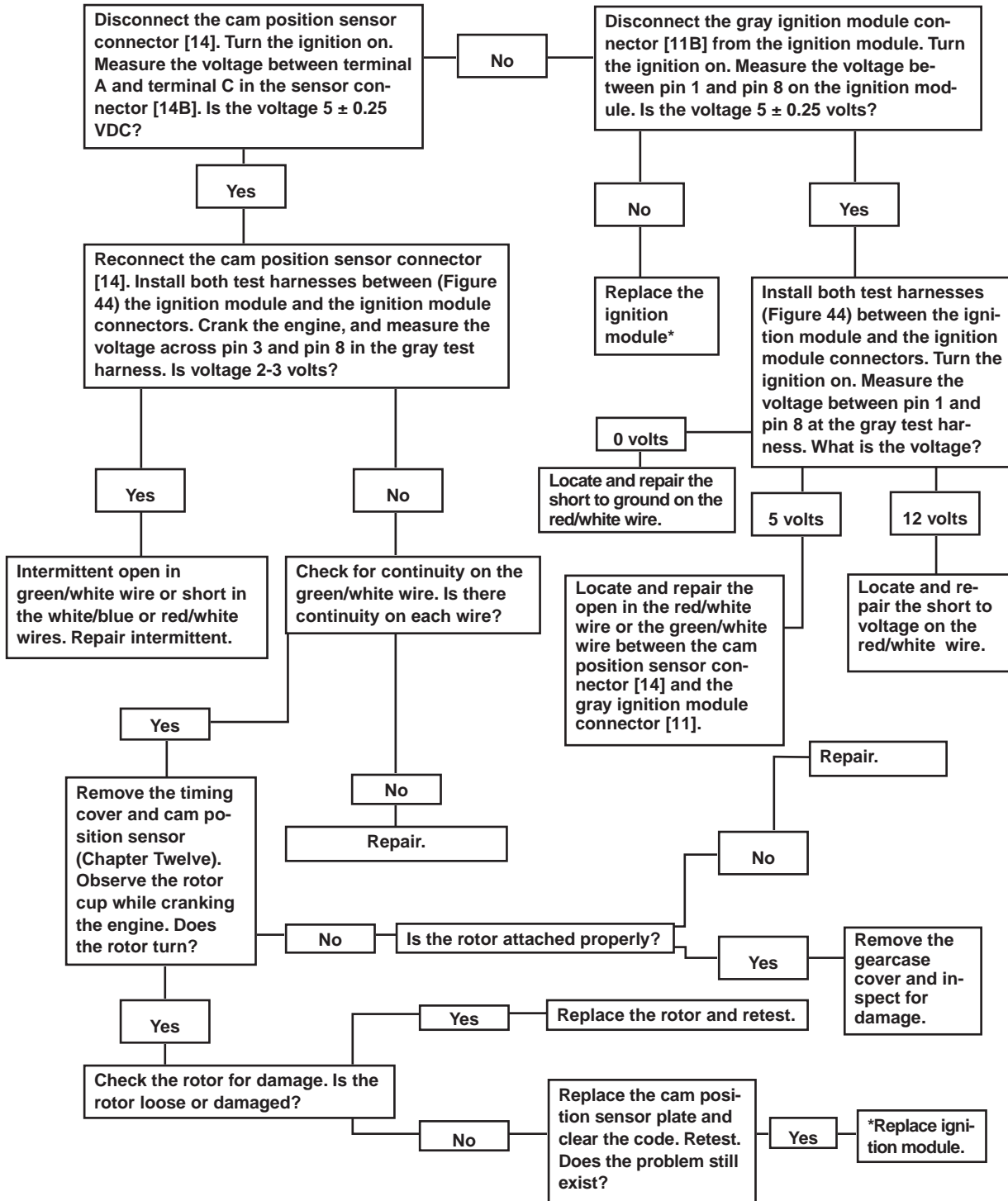

*Before replacing the ignition module, confirm it is defective by taking the motorcycle to a dealership. Further testing requires the Scanalyzer.

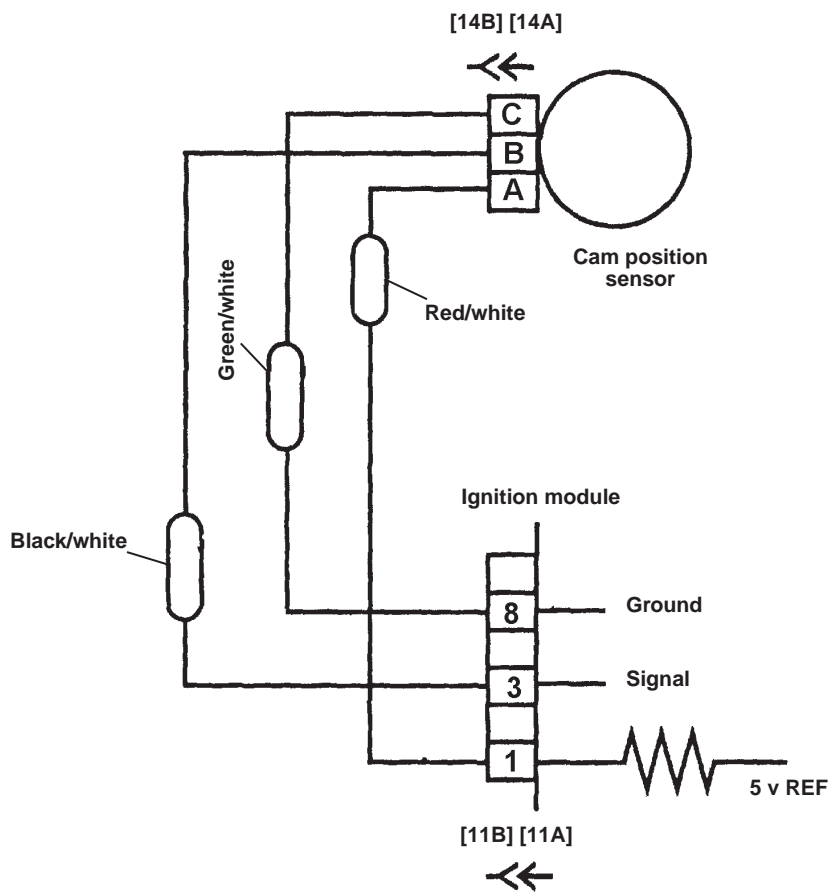

74

BANK ANGLE SENSOR

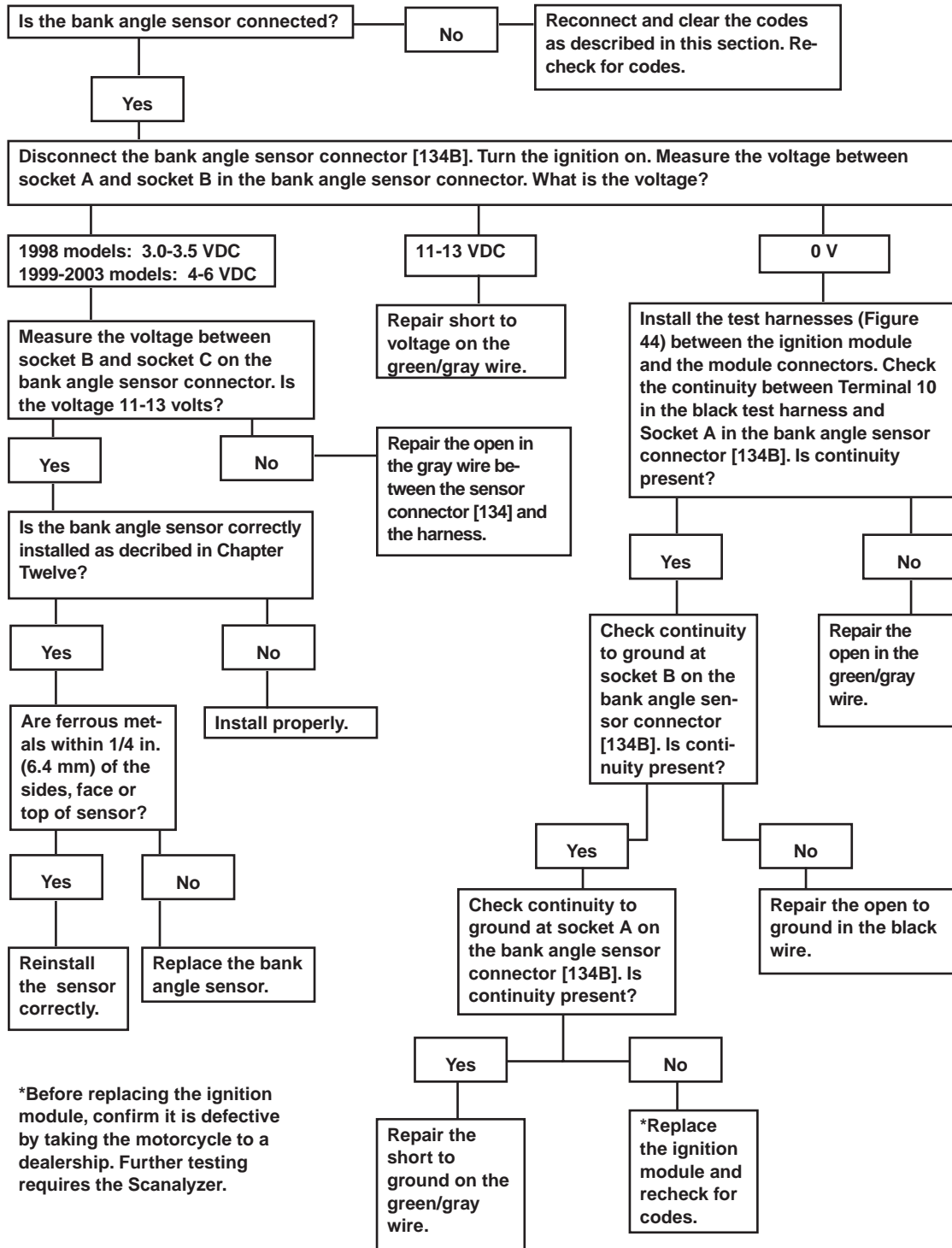

*Before replacing the ignition module, confirm it is defective by taking the motorcycle to a dealership. Further testing requires the Scanalyzer.

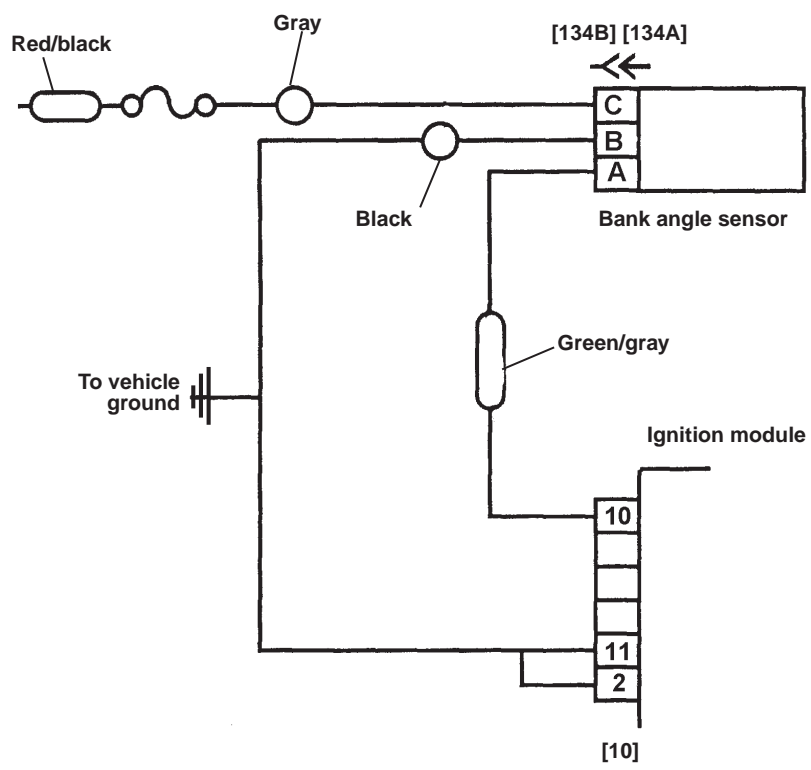

75

KEIHIN CARBURETOR TROUBLESHOOTING (1986-1987 MODELS)

Fuel overflows

Check:

- * Worn float needle valve or dirty seat
- * Incorrect float level
- * Damaged float bowl O-ring or loose float bowl mounting screws
- * Damaged float pin or loose locking screw
- * Damaged float

Poor idling

Check:

- * Idle misadjusted
- * Worn idle mixture screw
- * Blocked jet or port in carburetor bore
- * Air leak at carburetor mounting
- * Accelerator pump rod too long or misadjusted

Poor acceleration

Check:

- * Clogged accelerator pump
- * Worn accelerator pump diaphragm
- * Idle mixture misadjusted (early models with idle mixture adjustment)
- * Clogged pilot jet
- * Float level too high

Low power at all speeds

Check:

- * Dirty or plugged carburetor passages
- * Clogged fuel lines
- * Clogged fuel strainer in tank
- * Air leak at carburetor mount
- * Dirty air filter
- * Loose carburetor jets

Poor power at high speeds

Check:

- * Loose or clogged main jet
- * Incorrect float level
- * Dirty or plugged carburetor passages

Poor fuel economy

Check:

- * Float level too low
- * Loose jets
- * Clogged bleed tubes of jets
- * Choke not opening fully
- * Dirty air filter

Fuel starvation

Check:

- * Clogged fuel line
- * Carburetor dirty
- * Fuel tank strainers clogged or dirty
- * Accelerating pump not operating correctly
- * Fuel tank dirty

76

CV CARBURETOR TROUBLESHOOTING (1988-2003 MODELS)

Hard starting

Check:

- * Fuel overflow from float assembly
- * Enrichener system inoperative
- * Plugged pilot jet and/or passage
- * Fuel overflow

Fuel overflows

Check:

- * Incorrect fuel level
- * Damaged float assembly
- * Worn float needle valve or dirty seat
- * Incorrect float alignment
- * Damaged float bowl O-ring or loose float bowl mounting screws
- * Plugged fuel tank vent cap on 1990-1991 models
- * Plugged or damaged continuous vent system on 1992-2003 models
- * Incorrect fuel tank cap installed (non-vent type)

Poor idling

Check:

- * Incorrect idle speed
- * Plugged pilot jet system
- * Loose pilot jet
- * Air leak at carburetor mounting
- * Enrichener valve nut loose or damaged

Poor acceleration

Check:

- * Fuel level too low
- * Clogged fuel passages
- * Clogged jets
- * Plugged fuel tank vent cap on 1990-1991 models
- * Plugged or damaged continuous vent system on 1992-2003 models
- * Incorrect fuel tank cap installed (non-vent type)
- * Enrichener valve nut loose or damaged
- * Worn or damaged needle jet or needle
- * Throttle cable misadjusted
- * Air leak at carburetor mounting
- * Damaged vacuum piston

Poor power at low engine speeds

Check:

- * Incorrect idle speed adjustment
- * Contaminated air filter element
- * Damaged vacuum piston
- * Worn or damaged needle jet or needle
- * Clogged pilot jet system
- * Plugged float bowl vent or overflow
- * Enrichener valve nut loose or damaged
- * Plugged fuel tank vent cap on 1990-1991 models
- * Plugged or damaged continuous vent system on 1992-2003 models
- * Clogged fuel supply
- * Air leak at carburetor mounting

(continued)

76 (continued)

Poor power at high engine speeds

Check:

- * Incorrect fuel level
- * Loose or plugged main jet
- * Contaminated air filter element
- * Damaged vacuum piston
- * Worn or damaged needle jet or needle
- * Plugged float bowl vent or overflow
- * Enrichener valve nut loose or damaged
- * Plugged fuel tank vent cap on 1990-1991 models
- * Plugged or damaged continuous vent system on 1992-2003 models
- * Clogged fuel supply
- * Air leak at carburetor mounting

Poor fuel economy

Check:

- * Incorrect enrichment use
- * Damaged vacuum piston
- * Contaminated air filter element
- * Loose jets
- * Fuel level too high
- * Worn or damaged needle jet or needle
- * Plugged float bowl vent
- * Enrichener valve nut loose or damaged
- * Incorrect carburetor adjustment

Vacuum piston doesn't rise in bore correctly

Check:

- * Vacuum piston binds in bore
- * Diaphragm torn or damaged
- * Vacuum piston spring binding
- * Enrichener valve open or leaking
- * Diaphragm cap loose or damaged
- * Piston vent clogged
- * Diaphragm incorrectly installed (pinched at lip)

Vacuum piston doesn't close

Check:

- * Broken spring
- * Diaphragm torn or damaged
- * Vacuum piston binds in bore

acceleration. This causes the diaphragm to force fuel from the pump chamber, through a check valve and into the carburetor venturi. The diaphragm spring returns the diaphragm to the uncompressed position, which allows the chamber to refill with fuel.

If the engine hesitates during sudden acceleration, check the operation of the accelerator pump system. Carburetor service is covered in Chapter Ten or Chapter Eleven.

Vacuum-operated fuel shutoff valve testing (1995-2003 models)

A vacuum-operated fuel shutoff valve is used on 1995-2003 models. A vacuum hose is connected between the fuel shutoff valve diaphragm and the carburetor. When the engine is running, vacuum is applied to the fuel shutoff valve through this hose. For fuel to flow through the fuel

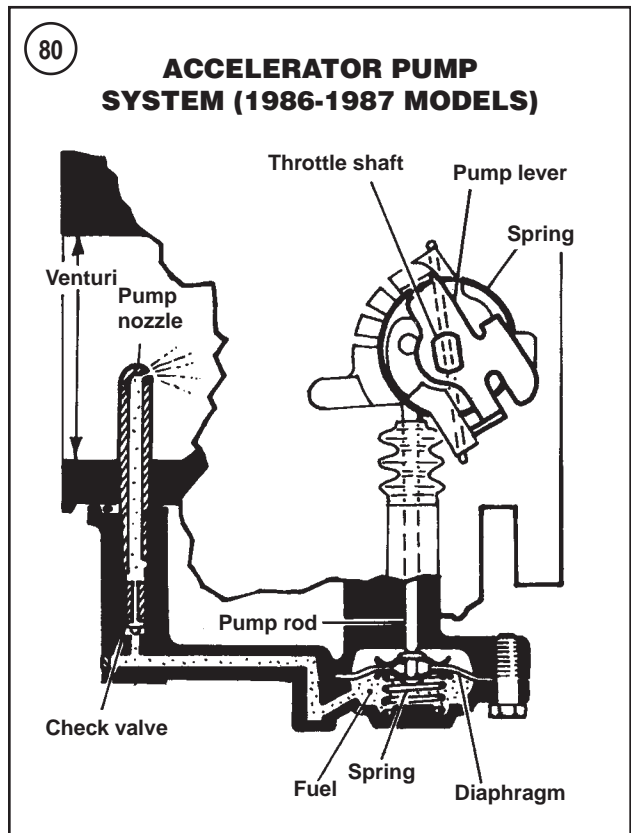
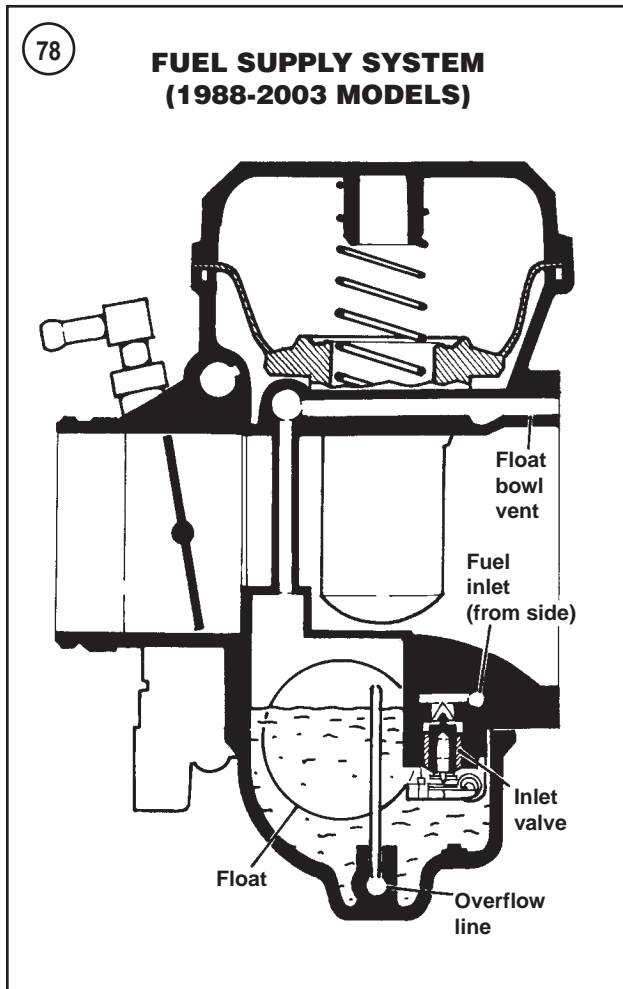
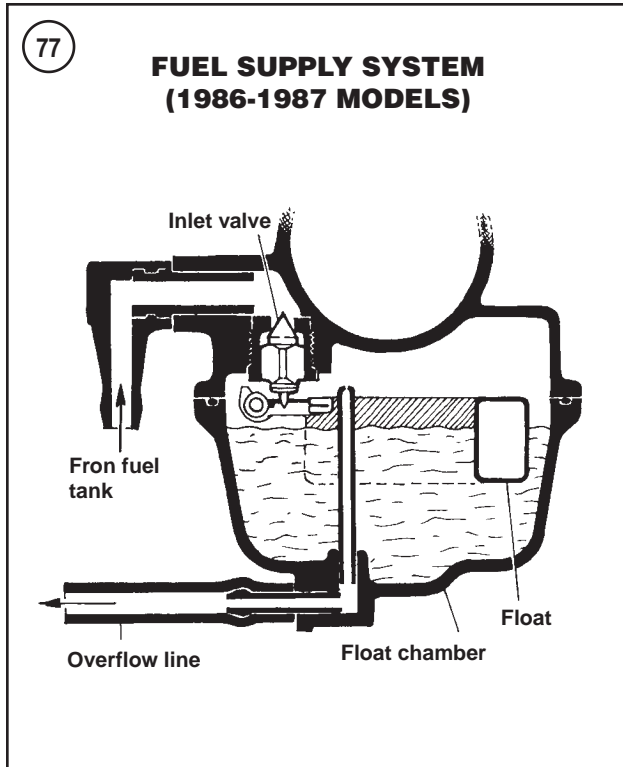

valve, a vacuum must be present with the fuel shutoff valve handle in the on or reserve position. The following steps troubleshoot the fuel shutoff valve by applying a vacuum from a separate source. A hand-operated vacuum pump (Figure 82, typical), gas can, drain hose that is long enough to reach from the fuel valve to the gas can, and hose clamp are required for this test.

1. Refer to *Safety* in Chapter One.
2. Disconnect the negative battery cable as described in Chapter Twelve.
3. Visually check there is fuel in the tank.
4. Turn the fuel shutoff valve (A, Figure 79) to the off position and disconnect the fuel hose (B) from the fuel shutoff valve. Plug the open end of the hose.

5. Connect the drain hose to the fuel shutoff valve and secure it with a hose clamp. Insert the end of the drain hose into a gas can.
6. Disconnect the vacuum hose from the fuel shutoff valve.
7. Connect a hand-operated vacuum pump (**Figure 82**, typical) to the fuel shutoff valve vacuum hose nozzle.
8. Turn the fuel shutoff valve lever to the on position.

CAUTION

In Step 8, do not apply more than specified vacuum or the fuel shutoff valve diaphragm will be damaged.

9. Apply 25 in. (635 mm) Hg of vacuum to the valve. Fuel should flow through the fuel shutoff valve when the vacuum is applied.
10. With the vacuum still applied, turn the fuel shutoff valve lever to the reserve position. Fuel should continue to flow through the valve.
11. Release the vacuum and make sure the fuel flow stops.
12. Repeat Steps 9-11 five times. Fuel should flow with vacuum applied and stop flowing when the vacuum is released.
13. Turn the fuel shutoff valve off. Disconnect the vacuum pump and drain hoses.
14. Reconnect the fuel hose (B, **Figure 79**) to the fuel shutoff valve (A).
15. If the fuel valve failed this test, replace the fuel shutoff valve as described in Chapter Ten or Chapter Eleven.

ENGINE NOISES

1. A knocking or pinging during acceleration can be caused by using a lower octane fuel than recommended or a poor grade of fuel. Incorrect carburetor jetting and an incorrect spark plug heat range (too hot) can cause pinging. Refer to *Spark Plugs* in Chapter Three. Also check for excessive carbon buildup in the combustion chamber or a defective ignition module.
2. A slapping or rattling noise at low speed or during acceleration can be caused by excessive piston-to-cylinder wall clearance. Also check for a bent connecting rod(s) or worn piston pin and/or piston pin hole in the piston(s).
3. A knocking or rapping during deceleration is usually caused by excessive rod bearing clearance.
4. A persistent knocking and vibration or other noises are usually caused by worn main bearings. If the main bearings are in good condition, check for the following:
 - a. Loose engine mounts.
 - b. Cracked frame.
 - c. Leaking cylinder head gasket(s).
 - d. Exhaust pipe leaks at cylinder head(s).
 - e. Stuck piston ring(s).
 - f. Broken piston ring(s).
 - g. Partial engine seizure.
 - h. Excessive connecting rod bearing clearance.
 - i. Excessive connecting rod side clearance.

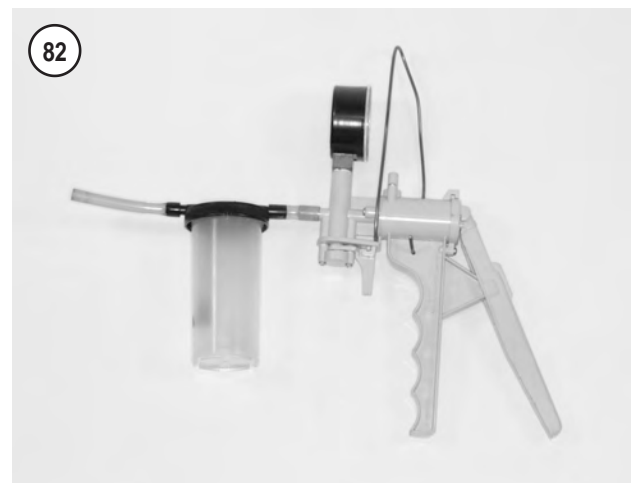
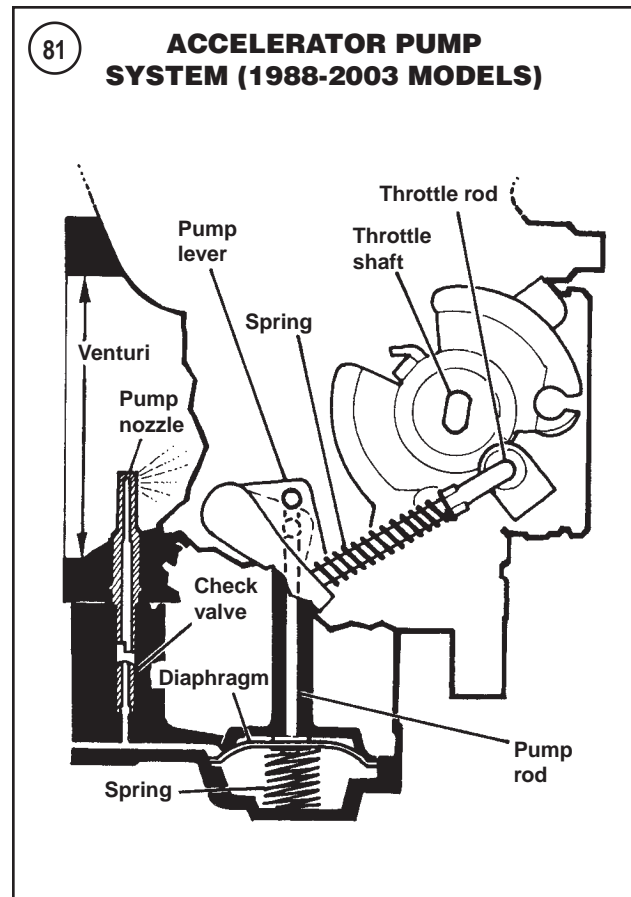

- j. Excessive crankshaft runout.
5. Rapid on-off squeal indicates a compression leak around the cylinder head gasket or spark plug.
6. For valve train noise, check for the following:
 - a. Bent pushrod(s).
 - b. Defective lifter(s).
 - c. Valve sticking in guide.
 - d. Worn cam gears and/or cam.
 - e. Damaged rocker arm or shaft. Rocker arm may be binding on shaft.

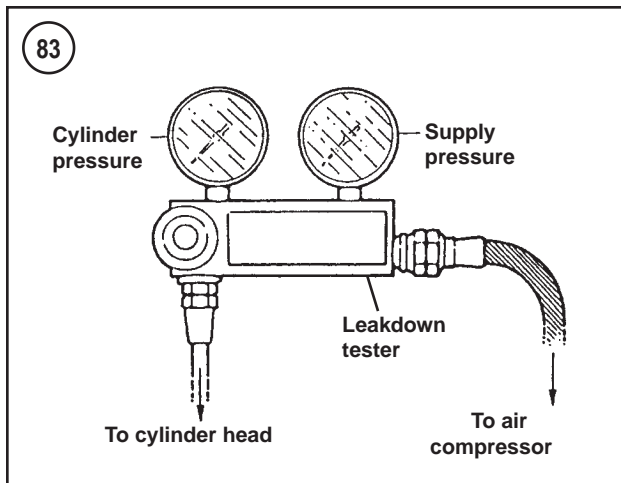

ENGINE SMOKE

The color of engine smoke can help diagnosis engine problems or operating conditions.

Black Smoke

Black smoke is an indication of a rich air/fuel mixture where an excessive amount of fuel is being burned in the combustion chamber.

Blue Smoke

Blue smoke indicates that the engine is burning oil in the combustion chamber as it leaks past worn valve stem seals and piston rings. Excessive oil consumption is another indicator of an engine that is burning oil. Perform a compression test (Chapter Three) to isolate the problem.

White Smoke or Steam

It is normal to see white smoke or steam from the exhaust after first starting the engine in cold weather. This is actually condensed steam formed by the engine during combus-

tion. If the motorcycle is ridden far enough, the water cannot buildup in the crankcase and should not be a problem. Once the engine heats up to normal operating temperature, the water evaporates and exits the engine. However, if the motorcycle is ridden for short trips or repeatedly started and stopped and allowed to cool off without the engine getting warm enough, water will start to collect in the crankcase. With each short run of the engine, more water collects. As this water mixes with the oil in the crankcase, sludge is produced. Water sludge can eventually cause engine damage as it circulates through the lubrication system and blocks off oil passages. Water draining from drain holes in exhaust pipes indicate water buildup.

LEAKDOWN TEST

A leakdown test can determine engine problems from leaking valves, blown head gaskets or broken, worn or stuck piston rings. A leakdown test is performed by applying compressed air to the cylinder and then measuring the loss percentage. A cylinder leakdown tester (**Figure 83**, typical) and an air compressor are required to perform this test.

Follow the manufacturer's directions along with the following information when performing a cylinder leakdown test.

1. Start and run the engine until it reaches normal operating temperature.
2. Remove the air filter (Chapter Three). Then set the throttle and choke valves in the wide open position.
3. Remove the ignition timing inspection plug from the crankcase (**Figure 84**).
4. Set the piston for the cylinder being tested to TDC on its compression stroke. Refer to *Ignition Timing* in Chapter Three.
5. Remove the spark plugs (Chapter Three).

NOTE

The engine may want to turn over when air pressure is applied to the cylinder. To prevent this from happening, shift the transmission into fifth gear and apply the rear brake.

6. Make a leakdown test following the leakdown tester manufacturer's instructions. Listen for air leaking while noting the following:

- a. Air leaking through the exhaust pipe indicates a leaking exhaust valve.
- b. Air leaking through the carburetor indicates a leaking intake valve.

NOTE

Air leaking through the valves can also be caused by pushrods that are too long.

- c. Air leaking through the ignition timing inspection hole indicates worn or broken piston rings, a leaking cylinder head gasket or a worn piston.

7. Repeat for the other cylinder.
8. If the pressure loss between cylinders differs by more than 12 percent, the engine is in poor condition and further testing is required.

ENGINE LUBRICATION

An improperly operating engine lubrication system will quickly lead to engine damage. The engine oil tank should be checked weekly and the tank refilled as described in Chapter Three.

Oil pump service is covered in Chapter Five.

Oil Light

The oil light, mounted on the indicator light panel (**Figure 85**), will come on when the ignition switch is turned on before starting the engine. After the engine is started, the oil light should go off when the engine speed is above idle.

If the oil light does not come on when the ignition switch is turned on and the engine is not running, check for a burned out oil light bulb. If the bulb is okay, check the oil pressure switch (**Figure 86**) as described in Chapter Twelve.

If the oil light remains on when the engine speed is above idle, turn the engine off and check the oil level in the oil tank as described in Chapter Three. If the oil level is satisfactory, check the following:

1. Oil may not be returning to the tank from the return line. Check for a clogged or damaged return line or a damaged oil pump.
2. If the motorcycle is operated in conditions where the ambient temperature is below freezing, ice and sludge may be blocking the oil feed pipe. This condition will prevent the oil from circulating properly.

Oil Consumption High or Engine Smokes Excessively

1. Worn valve guides.
2. Worn valve guide seals.
3. Worn or damaged piston rings.
4. Restricted oil tank return line.
5. Oil tank overfilled.
6. Oil filter restricted.
7. Leaking cylinder head surfaces.

Oil Fails to Return to Oil Tank

1. Oil lines or fittings restricted or damaged.
2. Oil pump damaged or operating incorrectly.
3. Oil tank empty.
4. Oil filter restricted.

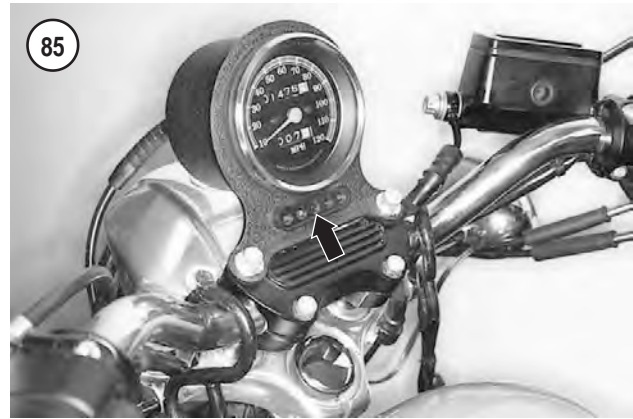

Excessive Engine Oil Leaks

1. Clogged air filter breather hose.
2. Restricted or damaged oil return line to oil tank.
3. Loose engine parts.
4. Damaged gasket sealing surfaces.
5. Oil tank overfilled.

CLUTCH

All clutch troubles, except adjustments, require partial clutch disassembly to identify and cure the problem. Refer to Chapter Six or Chapter Seven for clutch service procedures.

Make sure the clutch cable is properly adjusted (Chapter Three) before investigating internal problems.

Clutch Chatter or Noise

This problem is generally caused by worn or warped friction and steel plates. Also check for worn or damaged bearings.

Clutch Slip

1. Incorrect clutch adjustment.
2. Worn friction plates.
3. Weak or damaged diaphragm spring.
4. Damaged pressure plate.

Clutch Dragging

1. Incorrect clutch adjustment.
2. Warped clutch plates.
3. Worn or damaged clutch shell or clutch hub.

TRANSMISSION

Refer to Chapter Eight or Chapter Nine for transmission service procedures. Make sure that the clutch is not causing the trouble before working on the transmission.



Jumping Out of Gear

1. Incorrect shifter pawl adjuster.
2. Worn or damaged shifter parts.
3. Bent shift forks.
4. Severely worn or damaged gears.

Difficult Shifting

1. Worn or damaged shift forks.
2. Loose or damaged detent plate.
3. Worn or damaged shift shaft assembly.
4. Worn or damaged detent arm.
5. Worn shift fork drum groove(s).
6. Loose, worn or damaged shifter fork pin(s).
7. Damaged shift shaft splines.

Excessive Gear Noise

1. Worn or damaged bearings.
2. Worn or damaged gears.
3. Excessive gear backlash.

ELECTRICAL TESTING

This section describes typical test equipment and how to troubleshoot with it.

Never assume anything and do not overlook the obvious, such as a blown fuse or an electrical connector that has separated. Test the simplest and most obvious items first and try to make tests at easily accessible points on the motorcycle. Make sure to troubleshoot systematically.

Refer to the color wiring diagrams at the end of the manual for component and connector identification. Use the wiring diagrams to determine how the circuit should work by tracing the current paths from the power source through the circuit components to ground. Also check any circuits that share the same fuse, ground or switch. If the other circuits work properly and the shared wiring is good, the cause must be in the wiring used only by the suspect circuit. If all related circuits are faulty at the same time, the probable cause is a poor ground connection or a blown fuse(s).

Preliminary Checks and Precautions

Before starting any electrical troubleshooting, perform the following:

1. Inspect the fuse for the suspected circuit, and replace it if blown. Refer to *Circuit Breakers* and *Fuses* in Chapter Twelve.
2. Inspect the battery (Chapter Twelve). Make sure it is fully charged and the battery leads are clean and securely attached to the battery terminals.
3. Electrical connectors are often the cause of electrical system problems. Inspect the connectors as follows:
 - a. Disconnect each electrical connector in the suspect circuit and make sure there are no bent terminals in the electrical connector. A bent terminal will not connect to its mate, causing an open circuit.
 - b. Make sure the terminals are pushed all the way into the connector. If not, carefully push them in with a narrow blade screwdriver.
 - c. Check the wires where they attach to the terminals for damage.
 - d. Make sure each terminal is clean and free of corrosion. Clean them, if necessary, and pack the connectors with dielectric grease.
 - e. Push the connector halves together. Make sure the connectors are fully engaged and locked together.
 - f. Never pull the wires when disconnecting a connector. Pull only on the connector housing.
4. Never use a self-powered test light on circuits that contain solid-state devices. The solid-state devices may be damaged.

Intermittent Problems

Problems that do not occur all the time can be difficult to isolate during testing. For example, when a problem only occurs when the motorcycle is ridden over rough roads (vibration) or in wet conditions (water penetration). Note the following:

1. Vibration. This is a common problem with loose or damaged electrical connectors.
 - a. Perform a continuity test as described in the appropriate service procedure or under *Continuity Test* in this section.
 - b. Lightly pull or wiggle the connectors while repeating the test. Do the same when checking the wiring harness and individual components, especially where the wires enter a housing or connector.
 - c. A change in meter readings indicates a poor connection. Find and repair the problem or replace the part. Check for wires with cracked or broken insulation.

NOTE

An analog ohmmeter is useful when making this type of test. Slight needle movements are visibly apparent, which indicate a loose connection.

2. Heat. This is a common problem with connectors or joints that have loose or poor connections. As these connections heat up, the connection or joint expands and separates, causing an open circuit. Other heat related problems occur when a component starts to fail as it heats up.

- a. Troubleshoot the problem to isolate the circuit.

CAUTION

A heat gun will quickly raise the temperature of the component being tested. Do not apply heat directly to the circuit or use heat in excess of 140° F (60° C) on any electrical component.

- b. To check a connector, perform a continuity test as described in the appropriate service procedure or under *Continuity Test* in this section. Then repeat the test while heating the connector with a heat gun. If the meter reading was normal (continuity) when the connector was cold, and then fluctuated or read infinity when heat was applied, the connection is bad.
 - c. To check a component, allow the engine to cool, and then start and run the engine. Note operational differences when the engine is cold and hot.
 - d. If the engine will not start, isolate and remove the suspect component. Test it at room temperature and again after heating it with a heat gun. A change in meter readings indicates a temperature problem.
3. Water. When the problem occurs when riding in wet conditions or in areas with high humidity, start and run the engine in a dry area. Then, with the engine running, spray water onto the suspected component/circuit. Water-related problems often stop after the component heats up and dries.

Test Light or Voltmeter

Use a test light to check for voltage in a circuit. Attach one lead to ground and the other lead to various points along the circuit. It does not make a difference which test lead is attached to ground. The bulb lights when voltage is present.

Use a voltmeter in the same manner as the test light to find out if voltage is present in any given circuit. The voltmeter, unlike the test light, also indicates how much voltage is present at each test point.

Voltage test

Unless otherwise specified, make all voltage tests with the electrical connectors still connected. Insert the test leads into the backside of the connector and make sure the test lead touches the electrical terminal within the connector housing. If the test lead only touches the wire insulation, it will cause a false reading.

Always check both sides of the connector because one side may be loose or corroded, thus preventing electrical

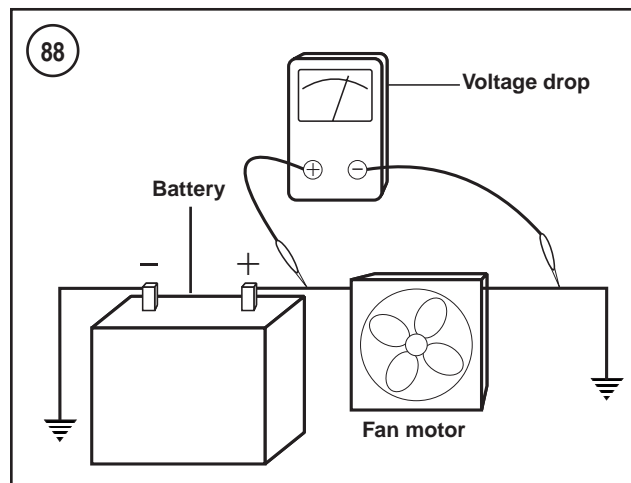
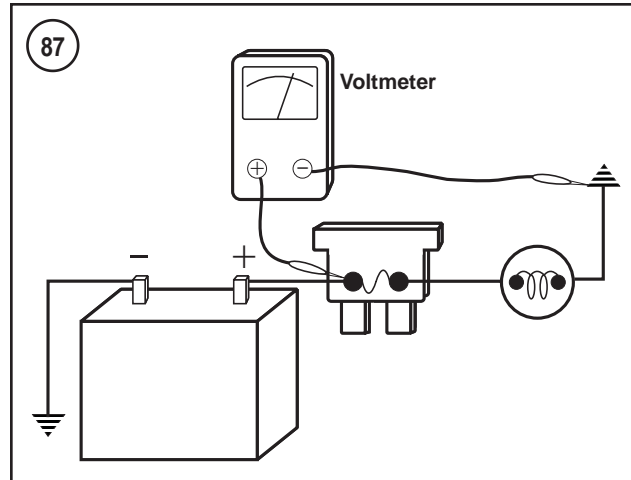

flow through the connector. This type of test can be performed with a test light or a voltmeter.

1. Attach the voltmeter negative test lead to a confirmed ground location. If possible, use the battery ground connection. Make sure the ground is not insulated.
2. Attach the voltmeter positive test lead to the point to be tested (**Figure 87**).
3. Turn the ignition switch on. If using a test light, the test light will come on if voltage is present. If using a voltmeter, note the voltage reading. The reading should be within 1 volt of battery voltage. If the voltage is less there is a problem in the circuit.

Voltage drop test

The wires, cables, connectors and switches in the electrical circuit are designed to carry current with low resistance. This ensures current can flow through the circuit with a minimum loss of voltage. Voltage drop indicates where there is resistance in a circuit. A higher-than-normal amount of resistance in a circuit decreases the flow of current and causes the voltage to drop between the source and destination in the circuit.

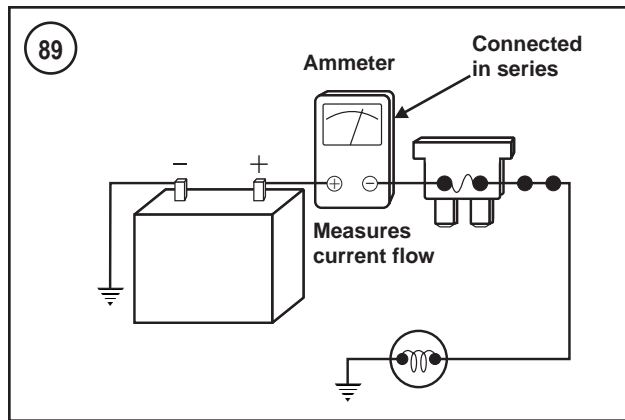

Because resistance causes voltage to drop, a voltmeter is used to measure voltage drop when current is running through the circuit. If the circuit has no resistance, there is no voltage drop so the voltmeter indicates 0 volts. The greater the resistance in a circuit, the greater the voltage drop reading.

To perform a voltage drop:

1. Connect the positive meter test lead to the electrical source (where electricity is coming from).
2. Connect the voltmeter negative test lead to the electrical load (where the electricity is going). Refer to **Figure 88**.
3. If necessary, activate the component(s) in the circuit.
4. Read the voltage drop (difference in voltage between the source and destination) on the voltmeter. Note the following:
 - a. The voltmeter should indicate 0 volts. If there is a drop of 1 volt or more, there is a problem within the circuit. A voltage drop reading of 12 volts indicates an open in the circuit.
 - b. A voltage drop of 1 or more volts indicates that a circuit has excessive resistance.
 - c. For example, consider a starting problem where the battery is fully charged but the starter turns over slowly. Voltage drop would be the difference in the voltage at the battery (source) and the voltage at the starter (destination) as the engine is being started (current is flowing through the battery cables). A corroded battery cable would cause a high voltage drop (high resistance) and slow engine cranking.
 - d. Common sources of voltage drop are loose or contaminated connectors and poor ground connections.

Short test

A test light may also be used.

1. Remove the blown fuse from the fuse panel.
2. Connect the voltmeter across the fuse terminals in the fuse panel. Turn the ignition switch on and check for battery voltage.
3. With the voltmeter attached to the fuse terminals, wiggle the wiring harness relating to the suspect circuit at approximately 6 in. (15 cm) intervals. Start next to the fuse panel

and work systematically away from the panel. Note the voltmeter reading while progressing along the harness.

4. If the voltmeter reading changes or the test light blinks, there is a short-to-ground at that point in the harness.

Ammeter

Use an ammeter to measure the flow of current (amps) in a circuit (**Figure 89**). When *connected in series* in a circuit, the ammeter determines if current is flowing through the circuit and if that current flow is excessive because of a short in the circuit. Current flow is often referred to as current draw. Comparing actual current draw in the circuit or component to current draw specification (if specified by the manufacturer) provides useful diagnostic information.

Self-powered Test Light

A self-powered test light can be constructed from a 12-volt light bulb, a pair of test leads and a 12-volt battery. When the test leads are touched together the light bulb should go on.

Use a self-powered test light as follows:

1. Touch the test leads together to make sure the light bulb goes on. If not, correct the problem.
2. Disconnect the motorcycle's battery or remove the fuse(s) that protects the circuit to be tested. Do not connect a self-powered test light to a circuit that has power applied to it.
3. Select two points within the circuit where there should be continuity.
4. Attach one lead of the test light to each point.
5. If there is continuity, the test light bulb will come on.
6. If there is no continuity, the test light bulb will not come on, indicating an open circuit.

Ohmmeter

CAUTION

To prevent damage to the ohmmeter, never connect it to a circuit that has power applied to it. Always disconnect the battery negative lead before using an ohmmeter.

Use an ohmmeter to measure the resistance (in ohms) to current flow in a circuit or component.

Ohmmeters may be analog type (needle scale) or digital type (LCD or LED readout). Both types of ohmmeters have a switch that allows the user to select different ranges of resistance for accurate readings. The analog ohmmeter also has a set-adjust control, which is used to zero or calibrate the meter (digital ohmmeters do not require calibration). Refer to the ohmmeter's instructions to determine the correct scale setting.

Use an ohmmeter by connecting its test leads to the circuit or component to be tested. If an analog meter is used, it must be calibrated by touching the test leads together and turning

the set-adjust knob until the meter needle reads zero. When the leads are uncrossed, the needle should move to the other end of the scale, indicating infinite resistance.

During a continuity test, a reading of infinite resistance indicates an open in the circuit or component. A reading of zero indicates continuity, that is, there is no measurable resistance in the circuit or component. A measured reading indicates the actual resistance to current flow that is present in that circuit. Even though resistance is present, the circuit has continuity.

Continuity test

Perform a continuity test to determine the integrity of a circuit, wire or component. A circuit has continuity if it forms a complete circuit; that is if there are no opens in either the electrical wires or components within the circuit. A circuit with an open, on the other hand, has no continuity.

This type of test can be performed with a self-powered test light or an ohmmeter. An ohmmeter gives the best results.

1. Disconnect the negative battery cable or disconnect the test circuit/component from its power source.
2. Attach one test lead (test light or ohmmeter) to one end of the part of the circuit to be tested.
3. Attach the other test lead to the other end of the part or the circuit to be tested.
4. The self-powered test light comes on if there is continuity. An ohmmeter reads 0 or low resistance if there is continuity. A reading of infinite resistance indicates no continuity; the circuit is open.
5. If testing a component, note the resistance and compare this to the specification if available.

Short test

An analog ohmmeter or one with an audible continuity indicator works best for short testing. A self-powered test light may also be used.

1. Disconnect the negative battery cable (Chapter Twelve).
2. If necessary, remove the blown fuse from the fuse panel (Chapter Twelve).
3. Connect one test lead of the ohmmeter to the load side (battery side) of the fuse terminal in the fuse panel.
4. Connect the other test lead to a confirmed ground location. Make sure the ground is not insulated. If possible, use the battery ground connection.
5. Wiggle the wiring harness relating to the suspect circuit at approximately 6 in. (15 cm) intervals. Watch the ohmmeter while progressing along the harness.
6. If the ohmmeter needle moves or the ohmmeter beeps, there is a short-to-ground at that point in the harness.

Jumper Wire

Use a jumper wire to bypass a potential problem and isolate it to a particular point in a circuit. If a faulty circuit

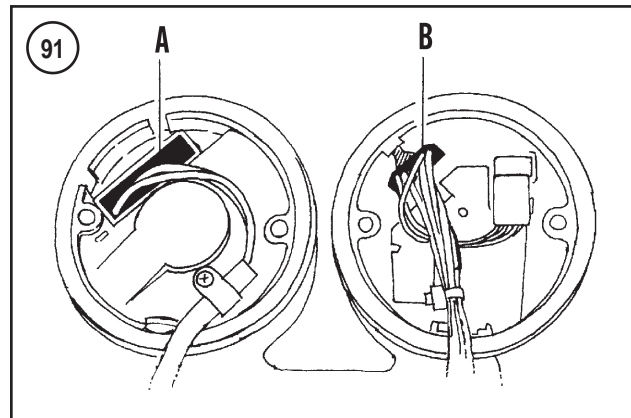
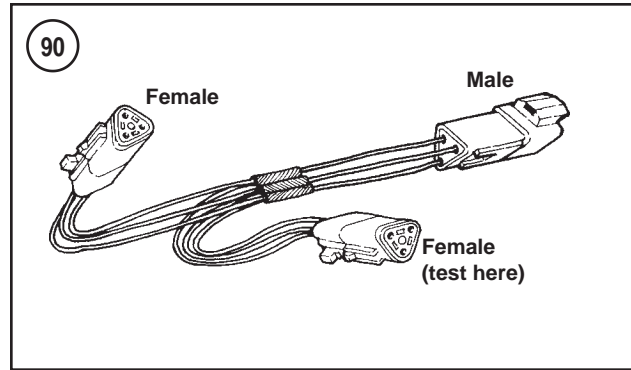

works properly with a jumper wire installed, an open exists between the two jumped points in the circuit.

To troubleshoot with a jumper wire, first use the wire to determine if the problem is on the ground side or the load side of a device. Test the ground by connecting the wire between the lamp and a good ground. If the lamp comes on, the problem is the connection between the lamp and ground. If the lamp does not come on with the wire installed, the lamp's connection to ground is good, so the problem is between the lamp and the power source.

To isolate the problem, connect the wire between the battery and the lamp. If it comes on, the problem is between these two points. Next, connect the wire between the battery and the fuse side of the switch. If the lamp comes on, the switch is good. By successively moving the wire from one point to another, the problem can be isolated to a particular place in the circuit.

Note the following when using a jumper wire:

1. Make sure the wire gauge (thickness) is the same as that used in the circuit being tested. Smaller gauge wire rapidly overheats and could melt.
2. Make sure the jumper wire has insulated alligator clips. This prevents accidental grounding (sparks) or possible shock. Install an inline fuse/fuse holder in the jumper wire.
3. A jumper wire is a temporary test measure. Do not leave a jumper wire installed as a permanent solution. This creates a fire hazard.

92

SPEEDOMETER DIAGNOSTIC CODES

| Diagnostic code | Fault | Troubleshooting chart |
|-----------------------------|---|---------------------------------------|
| d01 | Speed sensor power output shorted low | ¹ Figure 94 or Figure 96 |
| d02 | Speed sensor power output shorted high or open | ¹ Figure 94 or Figure 96 |
| d03 | Not used | – |
| d04 | Not used | – |
| d05 | Speed sensor return shorted high | ¹ Figure 94 or Figure 97 |
| d06 | Speed sensor return shorted low | ¹ Figure 94 or Figure 97 |
| d07 | Not used | – |
| d08 | Speedometer power overvoltage | ¹ Figure 94 or Figure 97 |
| d09 | Speed sensor output shorted high | ² Figure 100 or Figure 101 |
| d10 | Speed sensor output shorted low or open | ² Figure 100 or Figure 101 |
| CAL 14 | Speedometer application calibration number for domestic (U.S. models) | – |
| CAL 15 | Speedometer application calibration number for HDI models | – |
| 5-digit number ³ | Speedometer pulses per unit after all does are displayed | – |

1. Refer to Figure 94 for 1997-1998 models except late-model 1998 883 models. Refer to Figure 96 or Figure 97 for late model 1998 883 models and 1999 models.

2. Refer to Figure 100 for 1997-1998 models except late-model 1998 883 models. Refer to Figure 101 for late model 1998 883 models and 1999 models.

3. 2002-2003 models. Number will vary depending on part number.

4. Never use a jumper wire across any load (a component that is connected and turned on). This would cause a direct short and blow the fuse(s).

ELECTRONIC SPEEDOMETER/TACHOMETER

Refer to the following procedures to troubleshoot problems related to the electronic speedometer/tachometer.

Tools

A speedometer test harness is required to troubleshoot the speed sensor. Fabricate the harness from one 3-pin Deutsch male connector, two 3-socket Deutsch female connectors, and 6-inch lengths of 18-gauge wire. Use three wires to connect the male connector to one of the female connectors and splice the second female connector to the wires. See **Figure 90**.

During testing, connect the harness between the two sides of the speed sensor connector when instructed to install the test harness. Probe the second female connector at the indicated test points.

Speedometer Diagnostics (1998 883 and All 1999-2003 Models)

The speedometer in 1999-2003 models and in some late-model 1998 883 models has a self-diagnostic function. This speedometer can be identified by its amber back light

and its 12-terminal connector on the back of the speedometer (A, **Figure 91**).

When in the diagnostic mode, the speedometer runs a series of tests and then displays the results of these tests as diagnostic codes.

To enter the diagnostic mode, perform the following:

1. Press and hold the reset switch.
2. Turn the ignition on.
3. When you enter the diagnostic mode, the first code, d01, will appear in the odometer display followed by a status indicator, either SEt or CLr. For example: d01SEt indicates that code d01 has been set. The code d01CLr indicates d01 is clear.

NOTE

When in the diagnostic mode never press the reset switch for more than five seconds. This erases all stored diagnostic codes.

4. Briefly press the reset switch to display the next code and its status. Codes are displayed sequentially by code number.
5. Toggle through the codes one by one and note which codes have been set. When all codes have been displayed, the speedometer will display the calibration number (CAL 14 or CAL 15).
6. When a diagnostic code has been set, refer to the chart in **Figure 92** to identify the fault and appropriate troubleshooting chart (**Figures 93-97**).
7. Diagnostic codes are cleared whenever the reset switch is pressed and held for five seconds while the speedometer

93

ODOMETER, TRIP ODOMETER AND RESET SWITCH (1997-2003 MODELS)

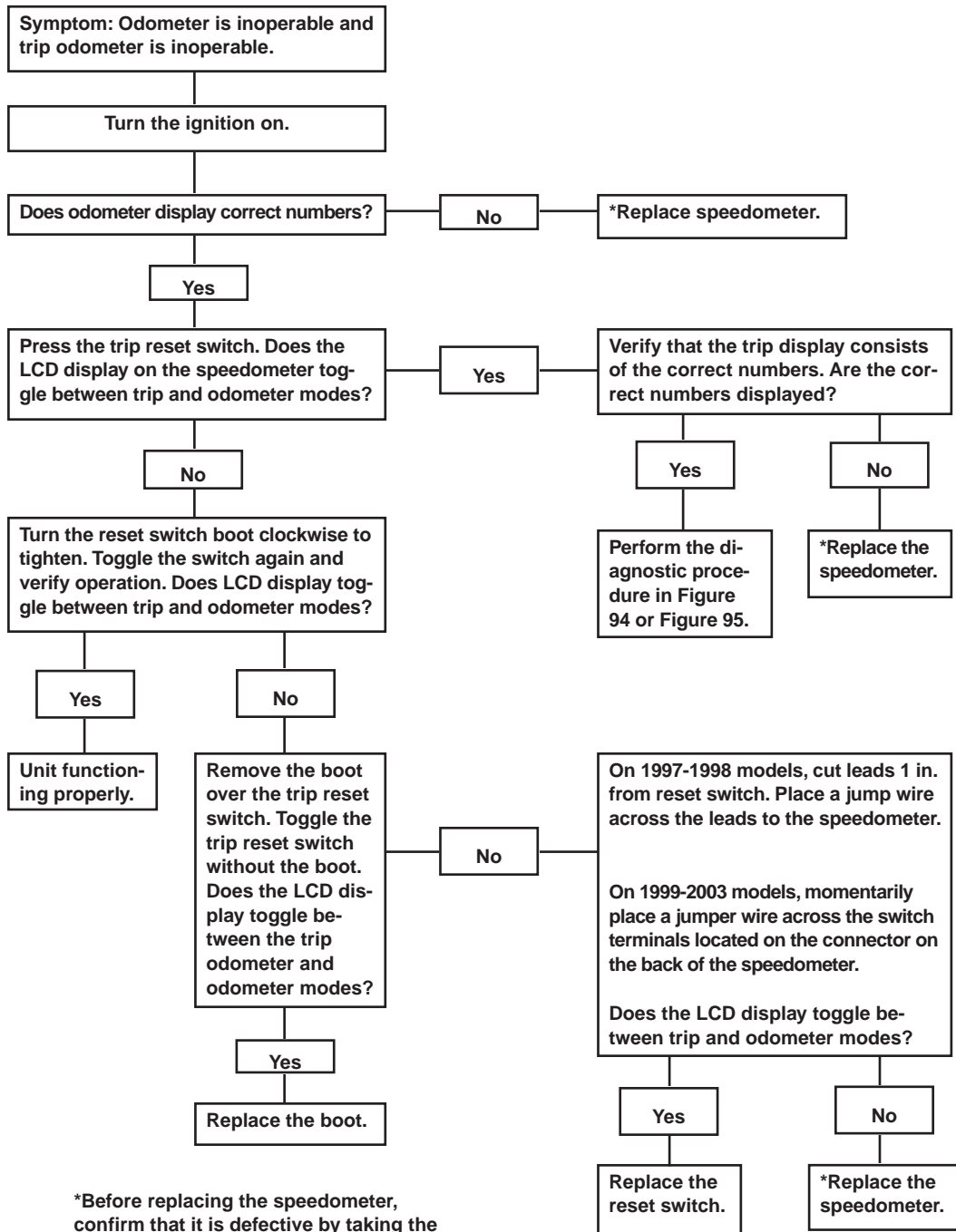

*Before replacing the speedometer, confirm that it is defective by taking the motorcycle to a dealership. Further testing requires the use of a Scanalyzer.

94

**INOPERATIVE, INACCURATE OR ERRATIC SPEEDOMETER
(1995-1998 MODELS EXCEPT LATE MODEL 1998 883 MODELS)**

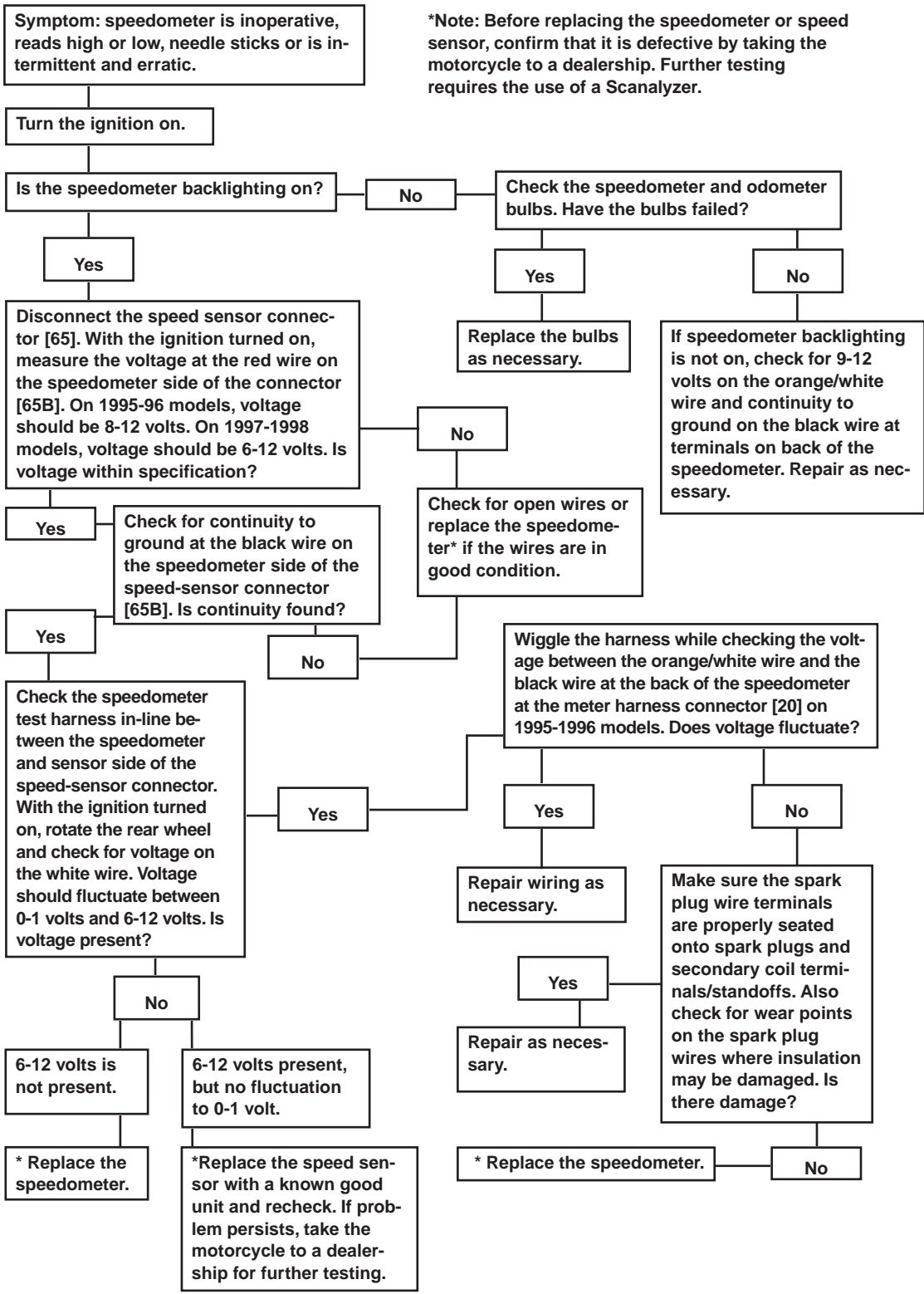

95

INOPERATIVE, INACCURATE OR ERRATIC SPEEDOMETER (LATE-MODEL 1998 883 AND 1999-2003 MODELS)

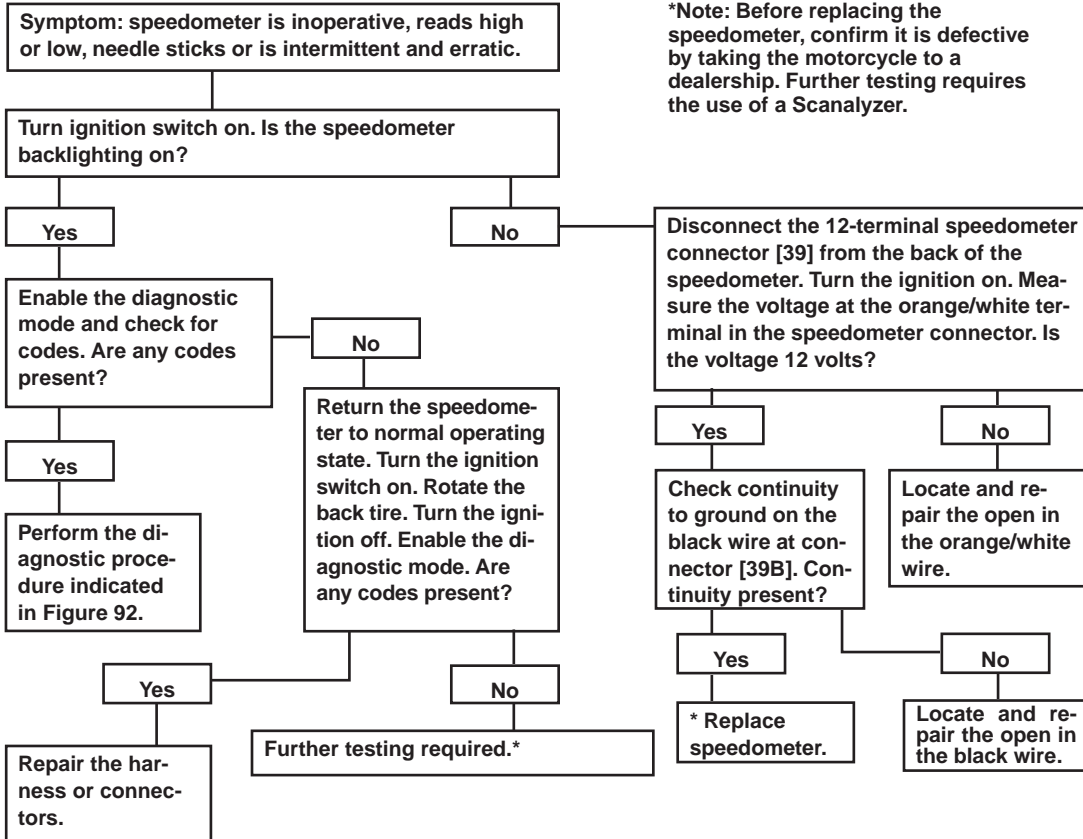

*Note: Before replacing the speedometer, confirm it is defective by taking the motorcycle to a dealership. Further testing requires the use of a Scanalyzer.

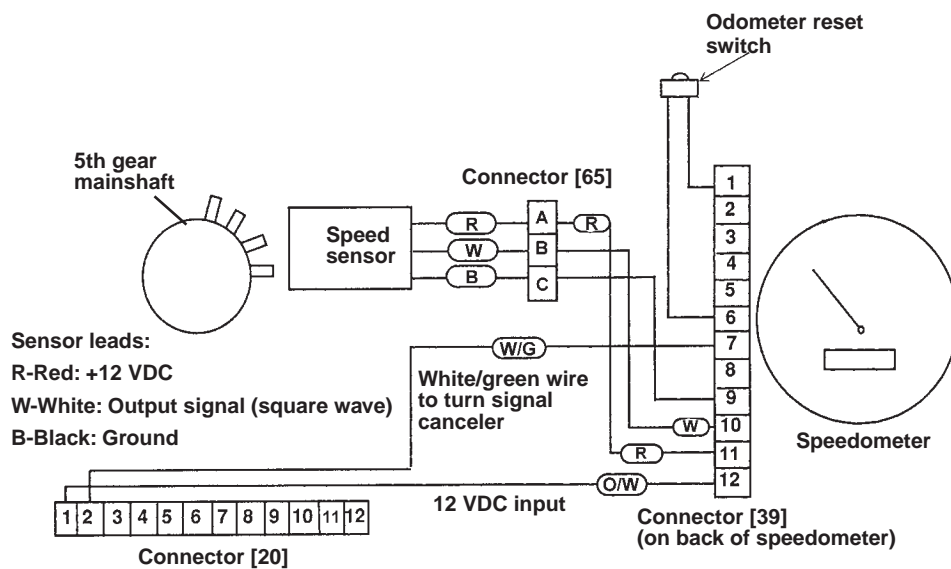

96

SPEEDOMETER DIAGNOSTIC CODES d01 AND d02 (LATE MODEL 1998 883 AND 1999-2003 MODELS)

***Note:** Before replacing the speedometer, confirm that it is defective by taking the motorcycle to a dealership. Further testing requires the use of a Scanalyzer.

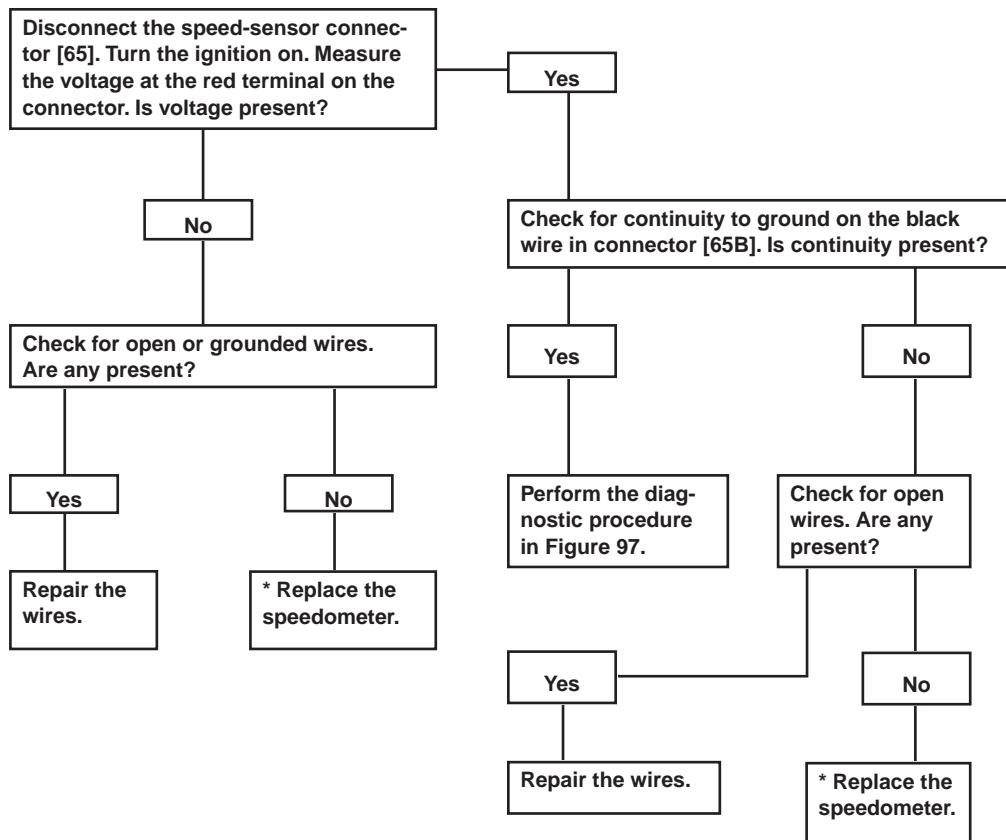

97

SPEEDOMETER: DIAGNOSTIC CODES d05, d06 AND d08 (LATE MODELS 1998 883 AND 1999-2003 MODELS)

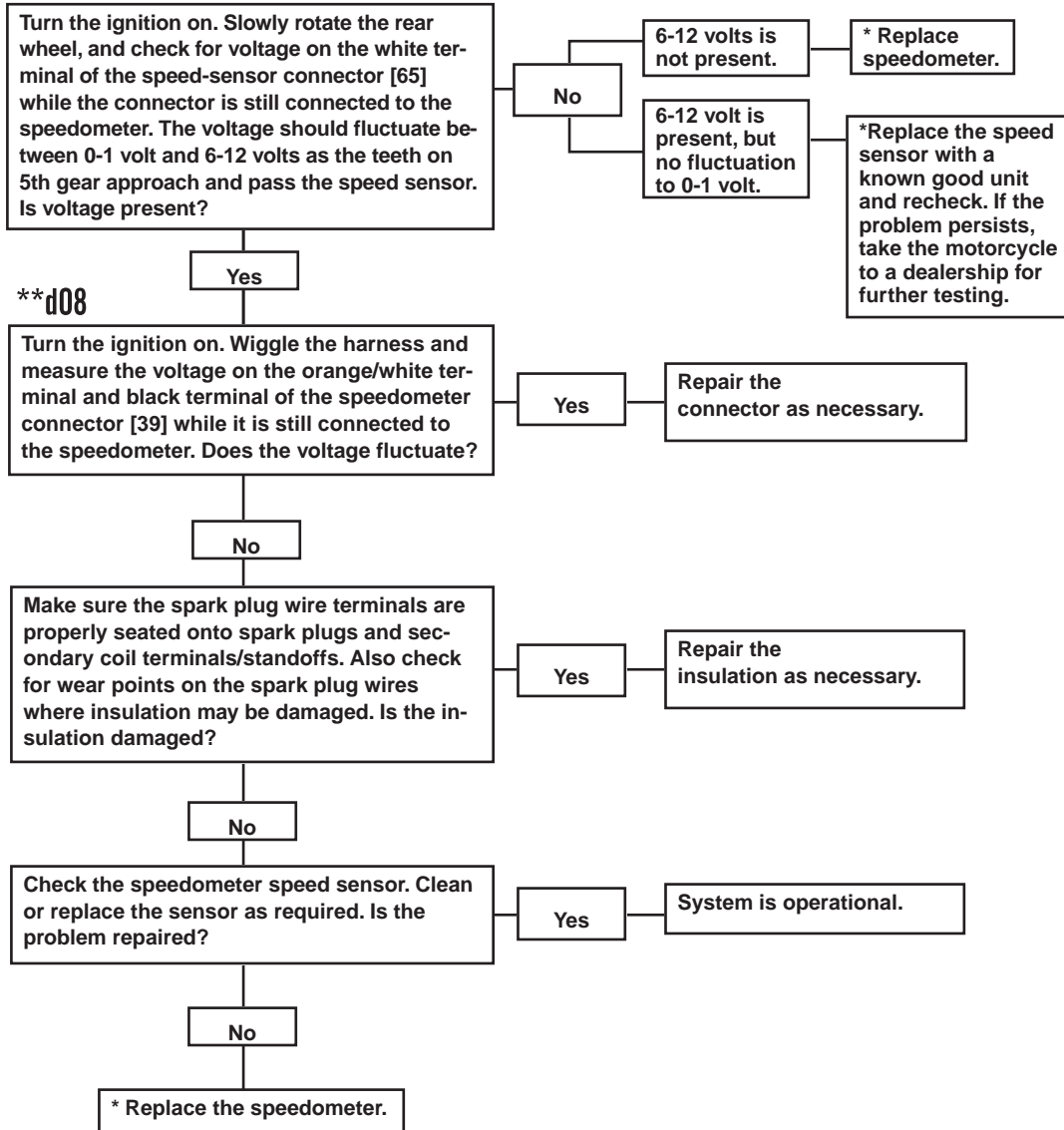

*Note: Before replacing the speedometer or speed sensor, confirm it is defective by taking the motorcycle to a dealership. Further testing requires the Scanalyzer.

**Begin troubleshooting diagnostic code d08 here.

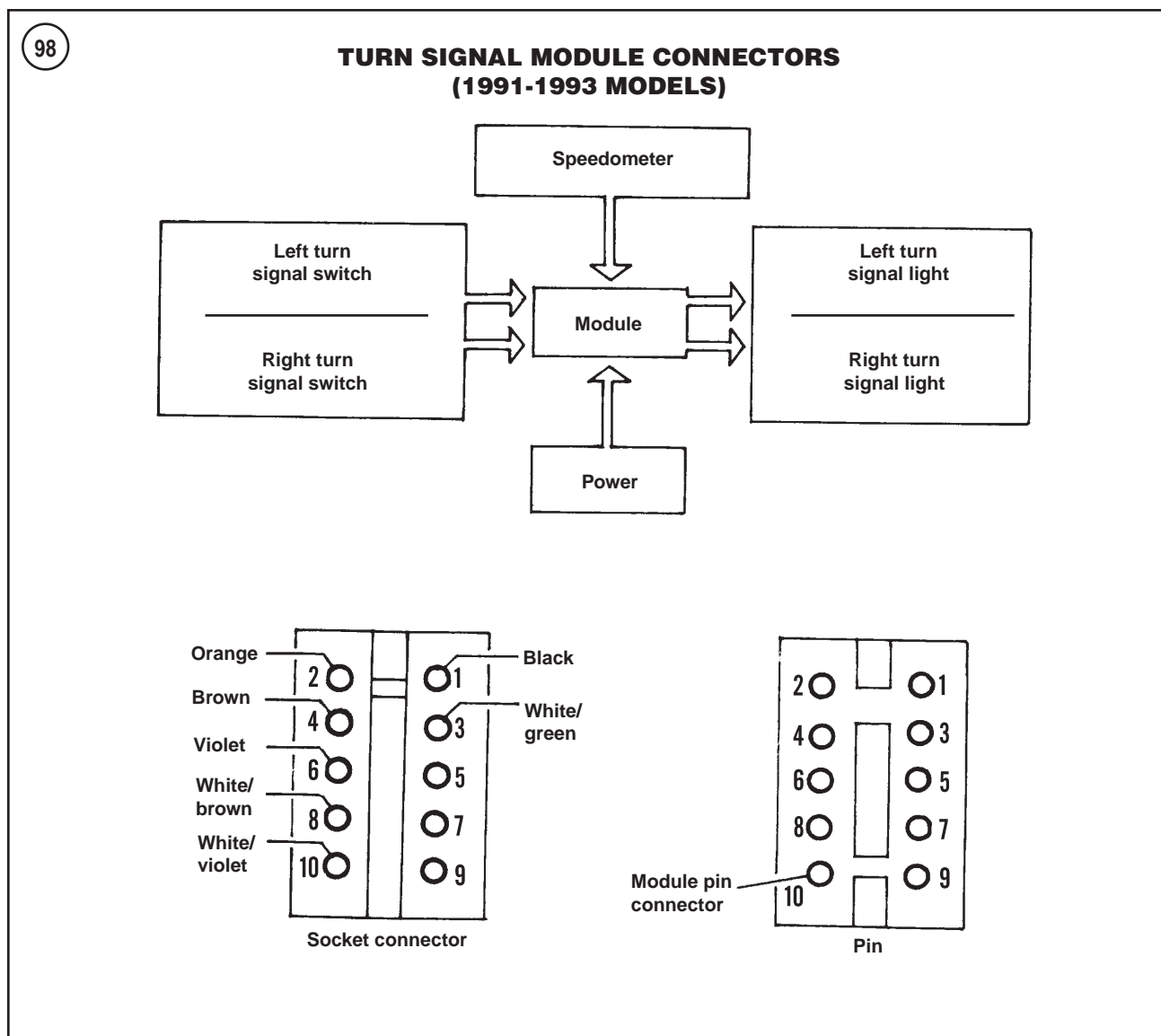

is in the diagnostic mode. All codes will be cleared whether they have been displayed or not.

8. To exit the diagnostic mode, turn the ignition switch from on to off and then to on again. Do not press the reset switch while doing so. Diagnostic codes are also cleared when the vehicle speed reaches 5 mph.

Speedometer/Tachometer Troubleshooting (1995-1998 Models, Except 1998 883 Models)

Find the symptom that best describes the condition in **Figure 93** or **Figure 94** and perform the indicated test procedures. Some test procedures, however, require the use of the speedometer tester (part No. HD-41354). Take the motorcycle to a dealership when indicated to do so in the troubleshooting chart.

TURN SIGNAL MODULE (1991-1996 MODELS)

Performance Test (1991-1993 Models)

If the turn signals are not working properly, perform the following performance test. A jumper wire, ohmmeter and voltmeter will be required.

1. Remove the turn signal module as described in Chapter Twelve.
2. After removing the module, identify the socket connector and module pin connectors using the diagram in **Figure 98**.
3. With ignition switch off, check for ground at pin No. 1.
4. Turn the ignition switch on.
5. Check for voltage at pin No. 2. Voltmeter should read 12 volts.
6. Connect a jumper wire between pins No. 2 and No. 4. The right front and rear turn signal lights should illuminate.

99

TURN SIGNAL MODULE CONNECTORS (1994-1996 MODELS)

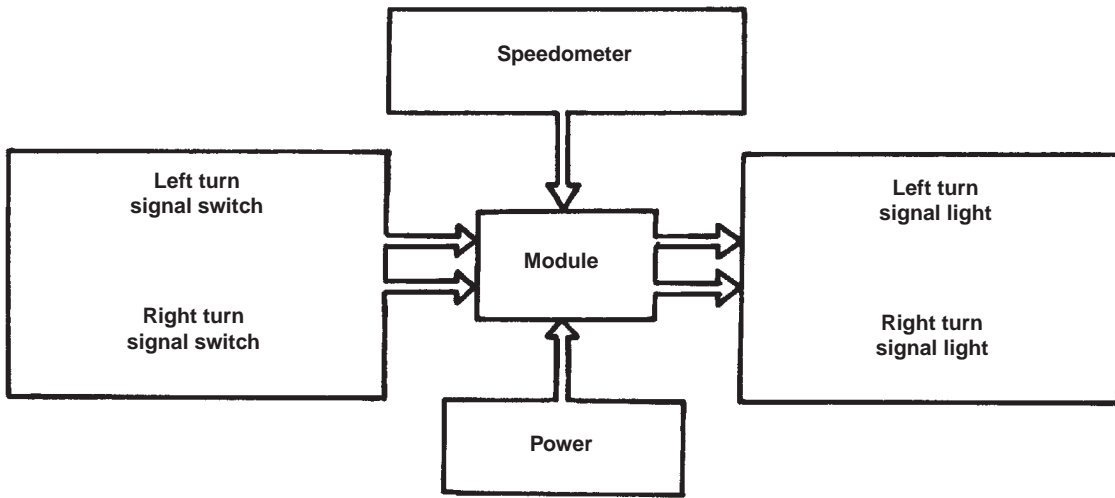
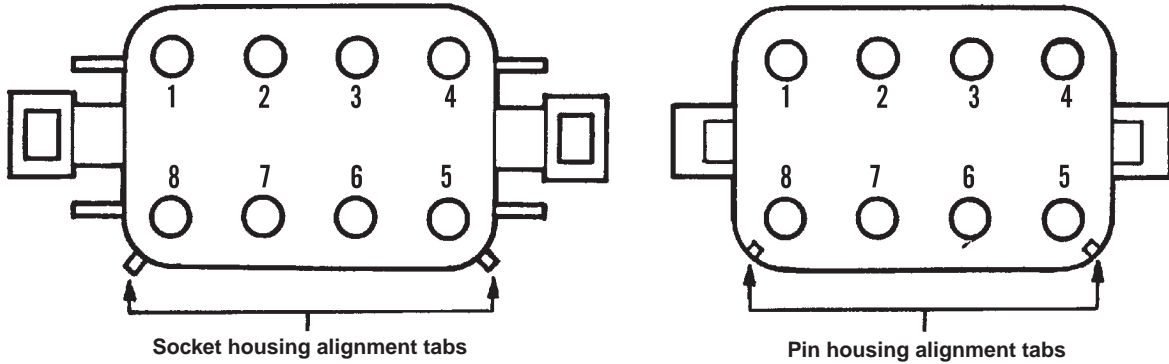

| Pin number | Wire color | Description/function |
|------------|--------------|---|
| 1 | Black | Module ground to motorcycle |
| 2 | Orange/white | 12vdc input from accessory circuit breaker |
| 3 | White/green | Speedometer reed switch input |
| 4 | Brown | Pulsed 12 vdc for flashing right turn signal lights |
| 5 | Violet | Pulsed 12 vdc for flashing left turn signal lights |
| 6 | White/brown | 12 vdc from right turn signal switch (when pressed) |
| 7 | White/violet | 12 vdc from left turn signal switch (when pressed) |
| 8 | - | Not used |

7. Connect a jumper wire between pins No. 2 and No. 6. The left front and rear turn signal lights should illuminate.
8. Connect a jumper wire between pins No. 4 and No. 8 and depress the right turn signal switch button. The right front and rear turn signal lights should illuminate.
9. Connect a jumper wire between pins No. 6 and No. 10 and depress the left turn signal switch button. The left front and rear turn signal lights should illuminate.
10. Remove the jumper wire and turn the ignition switch off.
11. If the module passed all six tests, the module is serviceable. If the module failed one or more tests, refer to *Troubleshooting* in this section.

Performance Test (1994-1996 Models)

If the turn signals are not working properly, perform the following performance test. A jumper wire, ohmmeter and voltmeter will be required.

1. Remove the turn signal module as described in Chapter Twelve.
2. After removing the module, identify the socket connector and module pin connectors using the diagram in **Figure 99**.
3. With ignition switch off, check for ground at pin No. 1.
4. Turn the ignition switch on.
5. Check for voltage at pin No. 2. Voltmeter should read 12 volts.
6. Connect a jumper wire between pins No. 2 and No. 4. The right front and rear turn signal lights should illuminate.
7. Connect a jumper wire between pins No. 2 and No. 5. The left front and rear turn signal lights should illuminate.

CAUTION

Do not use a jumper on 1996 models in Steps 8 or 9. The turn signal switch will be damaged.

- 8A. On 1994-1995 models, connect a jumper wire between pins No. 4 and No. 6 and depress the right turn signal switch button. The right turn signal lights should illuminate.
- 8B. On 1996 models, depress the right turn signal button and check for 12 volts at pin No. 6.
- 9A. On 1994-1995 models, connect a jumper wire between pins No. 5 and No. 7 and depress the left turn signal switch button. The Left turn signal lights should illuminate.
- 9B. On 1996 models, depress the left turn signal button and check for 12 VDC at pin No. 7.
10. Remove the jumper wire and turn the ignition switch off.
11. If the module passed all six tests, the module is serviceable. If the module failed one or more tests, refer to *Troubleshooting* in this section.

Troubleshooting

The following troubleshooting procedures help isolate specific problems to the module. If it is necessary to access the turn signal module, remove it as described in Chapter Twelve.

Refer to **Figure 98** or **Figure 99** for socket and module pin connector identification.

One or both turn signals do not flash. Light on front or rear side is lit, but does not flash

1. Remove the lens and check for a burned out bulb. Replace bulb if necessary.
2. If the bulb is good, check for the following:
 - a. Check the bulb socket contacts for corrosion. Clean contacts and recheck. If corrosion consistently builds on the contacts, wipe the contacts with a dielectric grease before installing the bulb.
 - b. Check for a broken bulb wire. Repair the wire or connector.
 - c. Check for a loose bulb socket where it is staked to the housing. If the bulb socket is loose, replace the light assembly.
 - d. Check for a poor ground connection. If the ground is poor, scrape the ground mounting area or replace damaged ground wire(s), as required.

Turn signals do not operate on one side

1. Perform the checks listed under *One or both turns signals do not flash. Light on front or rear side is lit, but does not flash* in this section. If these checks do not locate the problem, proceed to Step 2.
2. Inoperative handlebar directional switch. Perform the following:
 - a. Turn the ignition switch on.
 - b. Disconnect the turn signal module electrical connector.
 - c. Locate pin No. 8 or No. 10 (1991-1993 models) or pin No. 6 or No. 7 (1994-1996 models) on the socket connector.
 - d. With a voltmeter set on the DC scale, connect the negative lead to a good ground and the positive lead to one of the pin numbers specified in substep c and press the turn signal switch. The voltmeter should read 12 volts when the switch is pressed in.
 - e. If there is a 12 volt reading, proceed to Step 3.
 - f. If there is no voltage reading, proceed to Step 4.
3. If 12 volts were recorded in Step 2, and the lights and connecting wires are in good condition, the module may be damaged. Replace the module and retest.
4. If no voltage was recorded in Step 2, check the handlebar switch and related wiring for damage. Further tests can be made by performing continuity and voltage checks.
5. Reconnect the turn signal module electrical connector.

Turn signals/hazard lights do not operate on both sides

1. If none of the turn signals or hazard flashers operate, check the turn signal module for proper ground with an ohmmeter. Using the wiring diagram at the end of this manual, trace the ground connection from the module to the frame tab. If a ground is not present, remove the ground wire at the frame and scrape the frame and clean the connector. Check the ground wire for breaks. Repair as required. If a ground is present, perform Step 2.

CAUTION

Do not operate the module without pin No. 1 grounded. Otherwise, the module will burn out.

2. Refer to the appropriate wiring diagram and locate the accessory circuit breaker. Turn the ignition switch on and check for voltage on the hot or load side of the circuit breaker with a voltmeter. If there is no voltage, refer to Chapter Twelve and check the following components:

- a. Accessory circuit breaker.
- b. Main circuit breaker.
- c. Starter relay.
- d. Ignition switch.
- e. Circuit wiring.

Turn signals do not cancel

1. Support the motorcycle so that the front wheel clears the ground.

2A. On 1994 models, connect an ohmmeter to the speedometer white/green wire and ground. Spin the front wheel and watch the ohmmeter scale. The ohmmeter should alternate between 0 ohms and infinity.

- a. If ohmmeter reading is correct, disconnect the module pin connector. With a voltmeter set on the DC scale, connect the negative lead to a good ground and the positive lead to the No. 3 pin (white/green) socket connector. The voltmeter should read 12 volts. If ohm and volt readings are correct, the module is damaged.
- b. If ohmmeter reading is incorrect, check for damaged wiring from the speedometer white/green wire to the module. If wiring is okay, the reed switch in the speedometer may be damaged.

2B. On 1995-1996 models, set a voltmeter to the DC scale. Connect the positive meter lead to pin 3 and connect the negative meter lead to a good ground. Turn the ignition on and spin the rear wheel. The voltmeter readings should alternate between 0-1 volts and 8-12 volts. If the voltage is within specification, replace the turn signal module. If the readings are not within specification, check the speedometer wiring and the speedometer.

**TURN SIGNAL MODULE
(1997-2003 MODELS)**

Use the following troubleshooting charts (**Figures 100-103**) to help isolate specific turn signal problems. Find the particular symptom and follow the procedures until the problem is corrected. If it is necessary to access the turn signal module, remove it as described in Chapter Twelve.

The troubleshooting charts refer to various connectors by code numbers. The connectors are identified in the wiring diagrams located at the end of this manual.

Refer to **Figure 104** to identify the socket and pin connectors in the turn signal module connector.

EXCESSIVE VIBRATION

Excessive vibration is usually caused by loose engine mounting hardware. High speed vibration may be due to a bent axle shaft or loose or faulty suspension components. Vibration can also be caused by the following conditions:

1. Improperly balanced wheel(s).
2. Defective or damaged tire(s).
3. Defective or damaged wheel(s).
4. Tight primary chain links.
5. Severely worn primary chain.
6. Loose or damaged engine mounting bracket.
7. Internal engine wear or damage.
8. Broken frame.

FRONT SUSPENSION AND STEERING

Poor handling may be caused by improper tire pressure, a damaged or bent frame or front steering components, worn wheel bearings or dragging brakes.

Irregular or Wobbly Steering

1. Loose wheel axle nut(s).
2. Loose or worn steering head bearings.
3. Excessive wheel hub bearing play.
4. Damaged cast wheel.
5. Spoke wheel out of alignment.
6. Unbalanced wheel assembly.
7. Worn hub bearings.
8. Incorrect wheel alignment.
9. Bent or damaged steering stem or frame (at steering neck).
10. Tire incorrectly seated on rim.
11. Excessive front end loading from non-standard equipment.

Stiff Steering

1. Low front tire air pressure.
2. Bent or damaged steering stem or frame at the steering neck.

100

TURN SIGNALS WILL NOT CANCEL (1997-1998 MODELS, EXCEPT LATE-MODEL 1998 833 MODELS)*

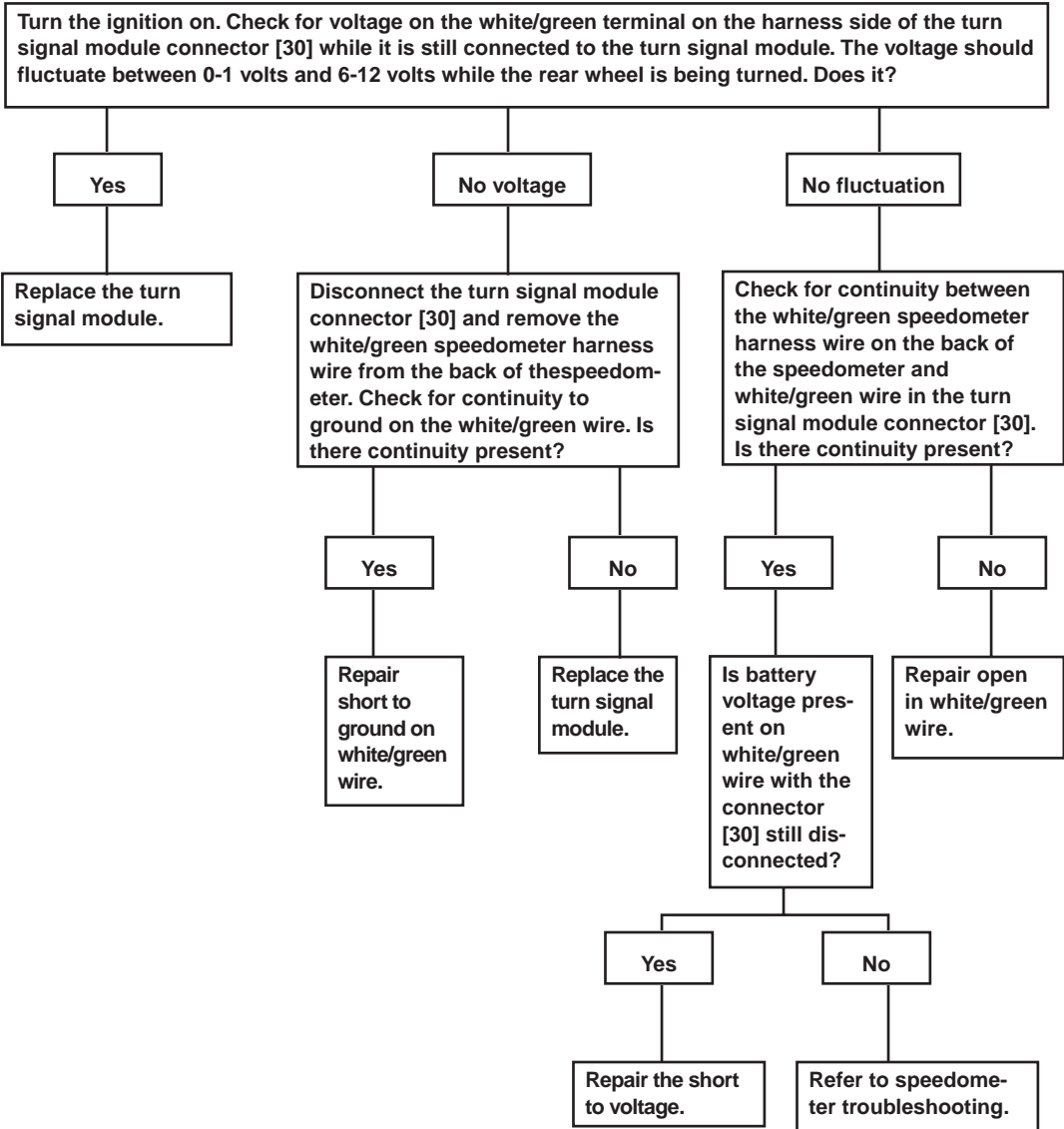

*Late model 1998 883 models are equipped with a speedometer featuring self-diagnostic capabilities.

101

TURN SIGNALS WILL NOT CANCEL (LATE MODEL 1998 883CC AND 1999-2003 MODELS)

Use this chart for speedometer trouble codes 9 (speed output shorted high) and 10 (speed output shorted low or open).

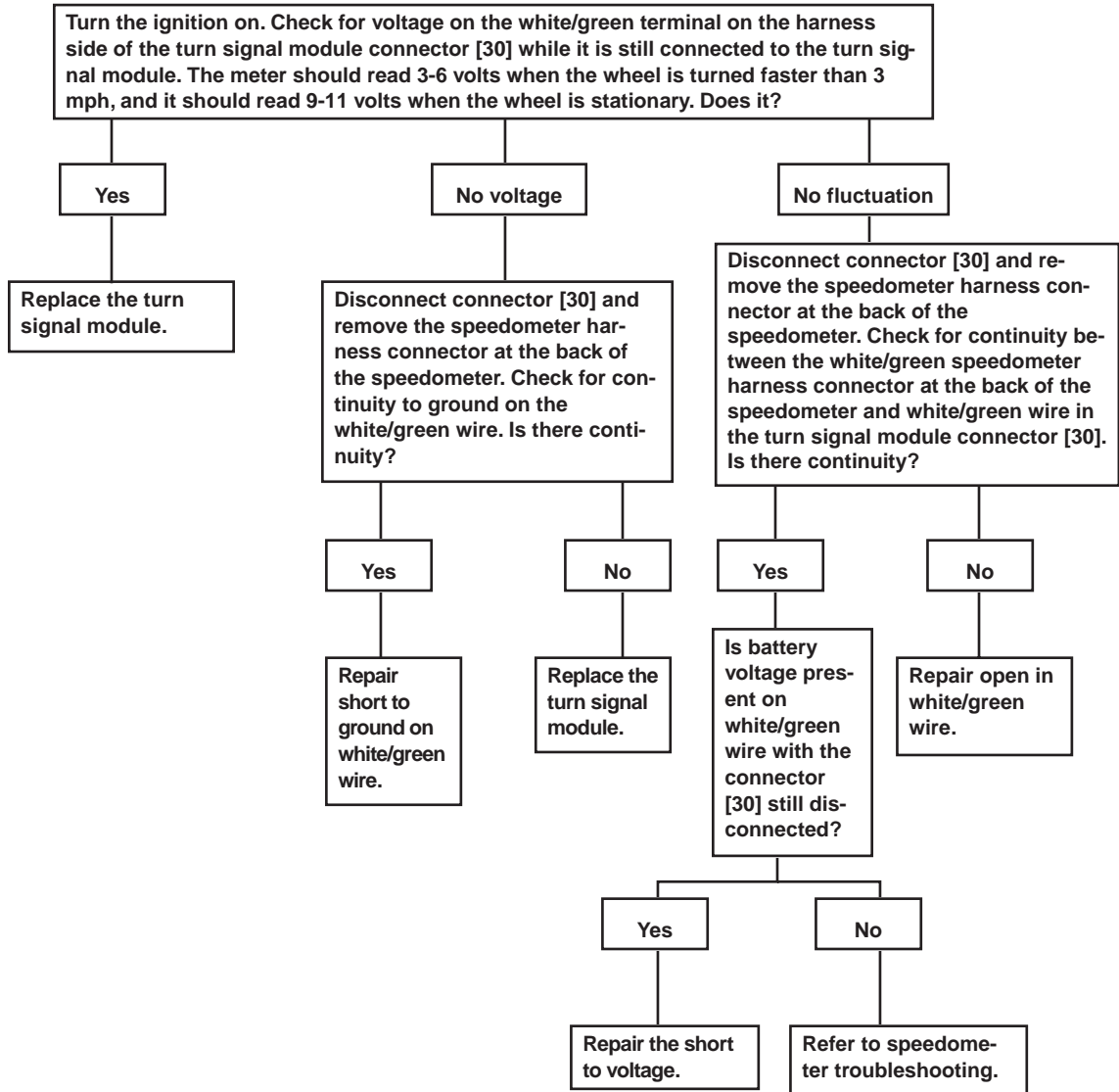

102

**TURN SIGNALS WILL NOT FLASH RIGHT, WILL NOT FLASH LEFT
(1997-2003 MODELS, EXCEPT LATE-MODEL 1998 883 MODELS)**

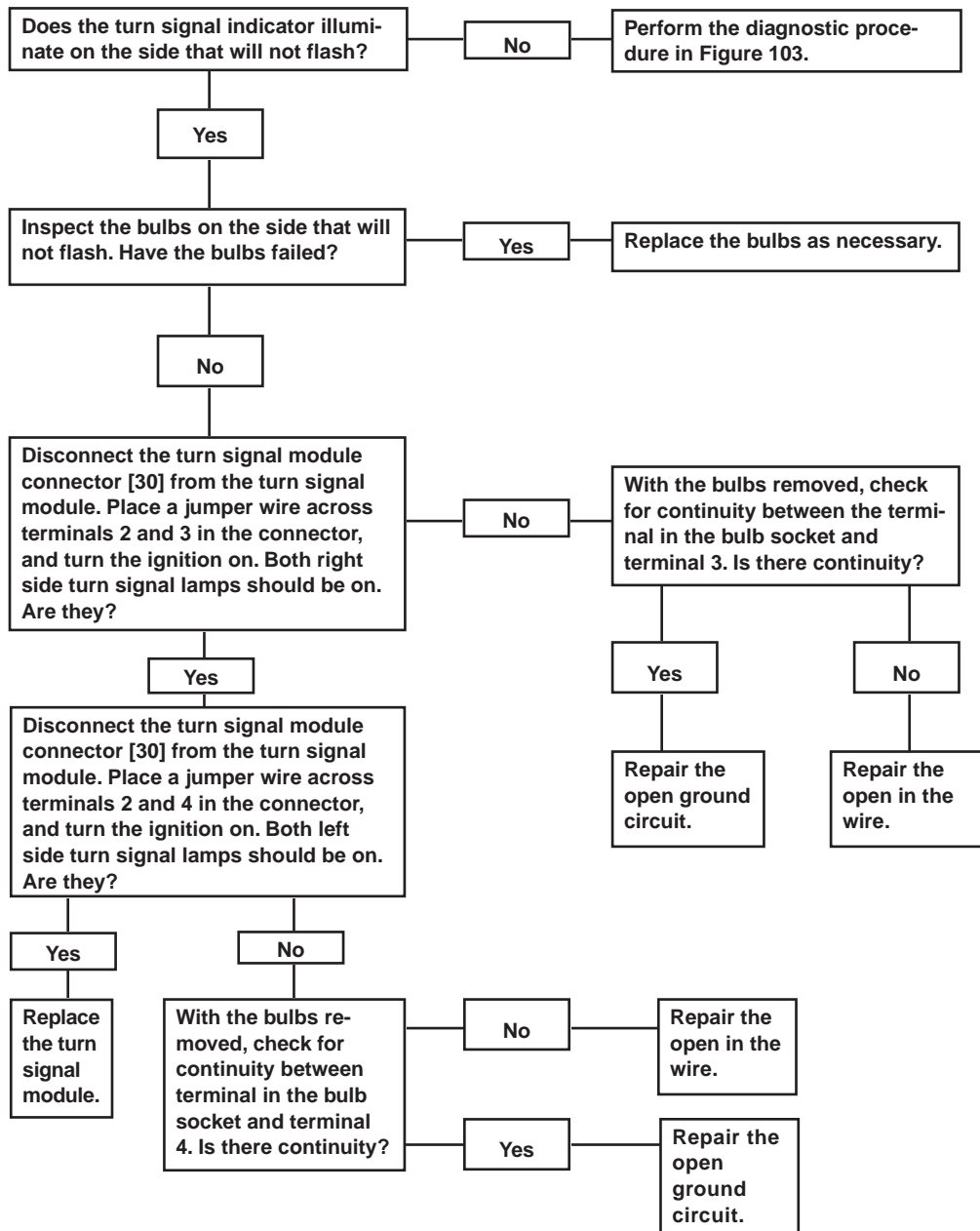

103

TURN SIGNALS WILL NOT FLASH, 4-WAY FLASHES INOPERABLE

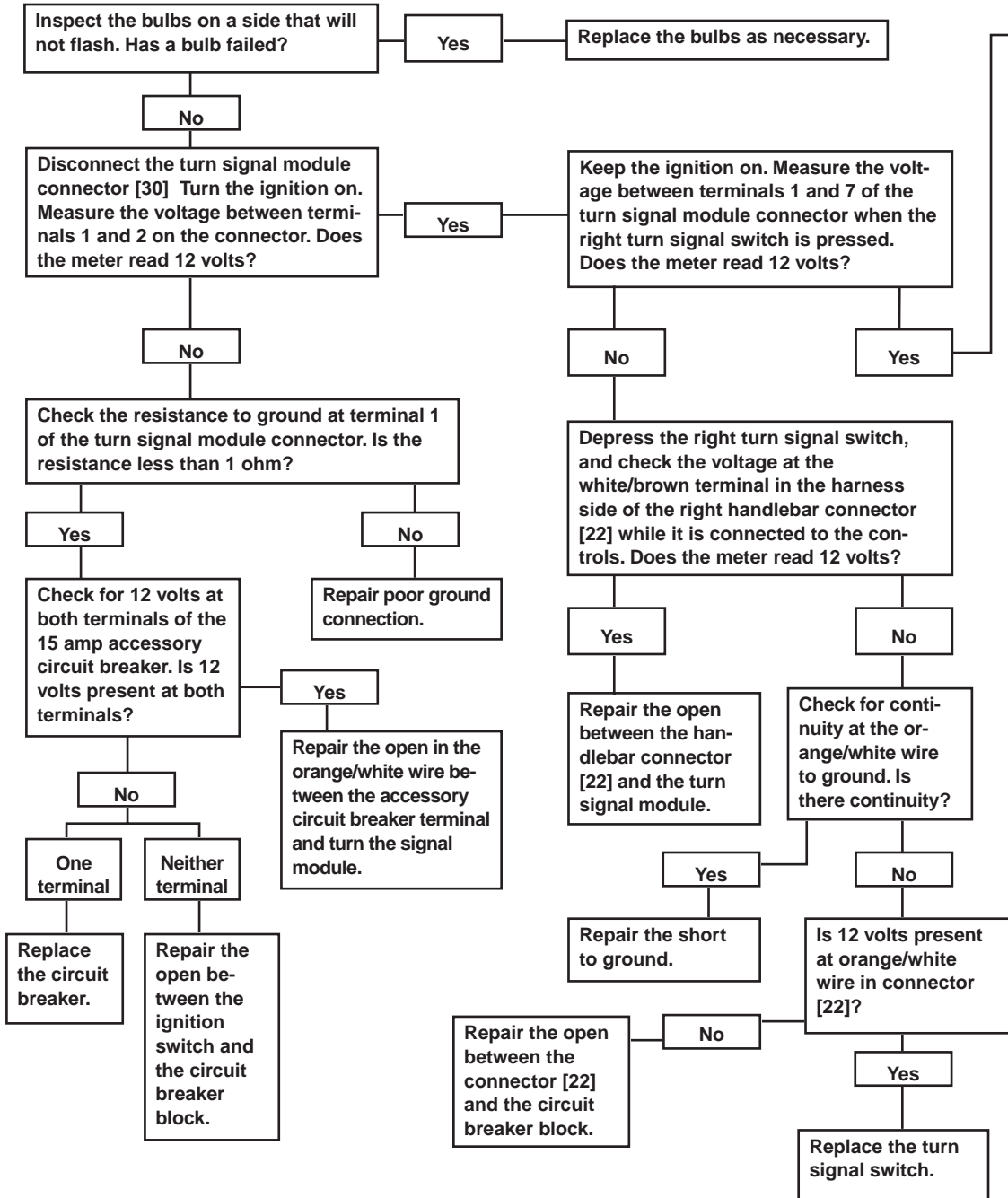

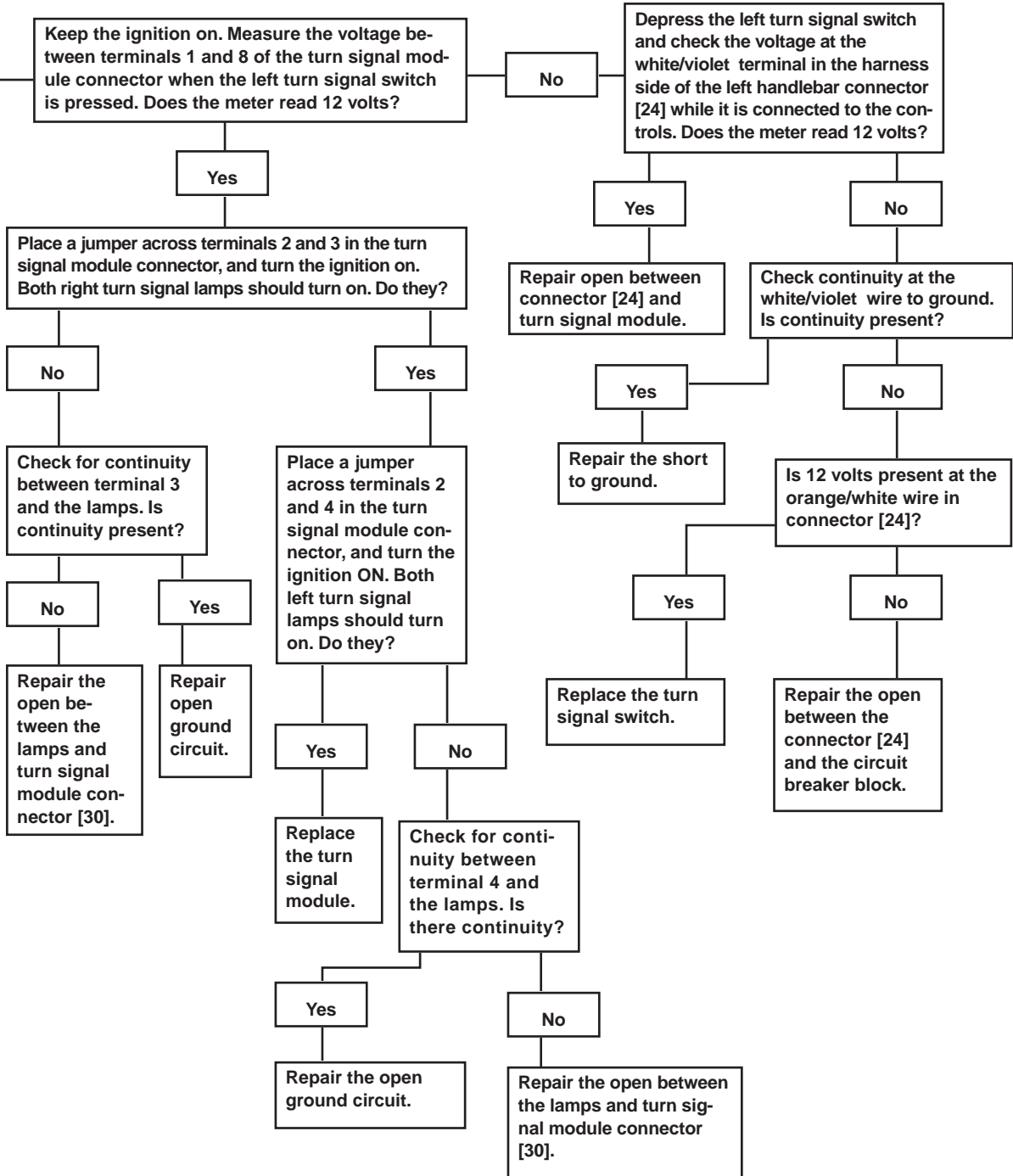

104

**TURN SIGNAL MODULE CONNECTORS
(1994-2003 MODELS)**

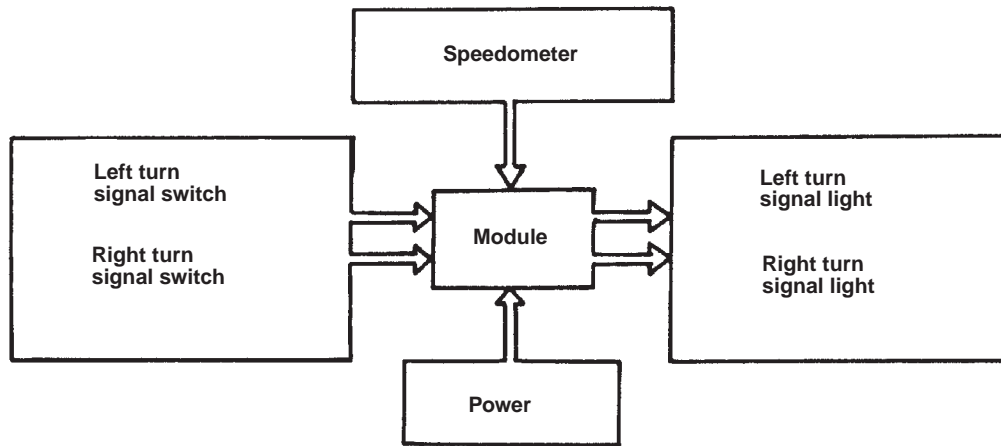
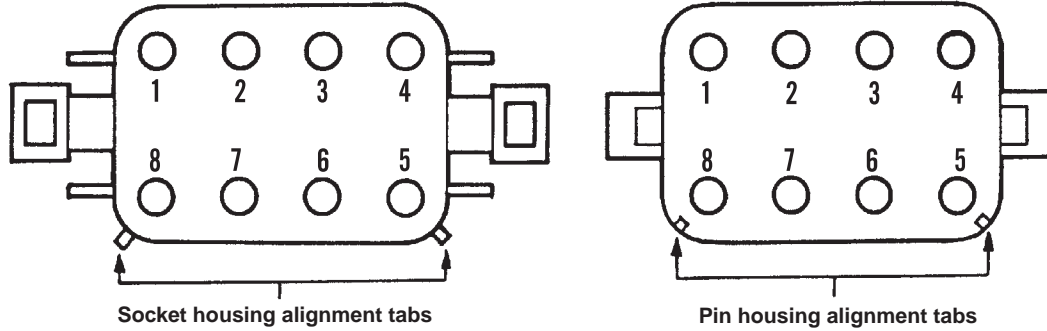

| Pin number | Wire color | Description/function |
|------------|--------------|---|
| 1 | Black | Module ground to motorcycle |
| 2 | Orange/white | 12vdc input from accessory circuit breaker |
| 3 | White/green | Speedometer reed switch input |
| 4 | Brown | Pulsed 12 vdc for flashing right turn signal lights |
| 5 | Violet | Pulsed 12 vdc for flashing left turn signal lights |
| 6 | - | Not used |
| 7 | White/brown | 12 vdc from right turn signal switch (when pressed) |
| 8 | White/violet | 12 vdc from left turn signal switch (when pressed) |

3. Loose or worn steering head bearings.

Stiff or Heavy Fork Operation

1. Incorrect fork oil viscosity.
2. Excessive amount of fork oil.
3. Bent fork tubes.
4. Incorrect fork springs.

Poor Fork Operation

1. Low fork oil level
2. Contaminated fork oil.
3. Worn or damaged fork tubes.
4. Bent or damaged fork tubes.
5. Incorrect fork springs.
6. Heavy front end loading from non-standard equipment.

Poor Rear Shock Absorber Operation

1. Rear shocks adjusted incorrectly.
2. Incorrect loading.
3. Heavy rear end loading from non-standard equipment.
4. Weak or worn springs.
5. Damper unit leaking.
6. Shock shaft worn or bent.
7. Incorrect rear shock springs.

BRAKE PROBLEMS

All models are equipped with front and rear disc brakes. Perform the maintenance specified in Chapter Three to minimize brake system problems. Brake system service is covered in Chapter Sixteen. When refilling the front and rear master cylinders, use only DOT 5 silicone-based brake fluid.

Insufficient Braking Power

Worn brake pads or disc, air in the hydraulic system, glazed or contaminated pads, low brake fluid level, or a leaking brake line or hose can cause this problem. Visually check for leaks. Check for worn brake pads. Also check for a leaking or damaged primary cup seal in the master cylinder. Bleed and adjust the brakes. Rebuild a leaking master cylinder or brake caliper. Brake drag will result in excessive heat and brake fade. See *Brake Drag* in this section.

Spongy Brake Feel

This problem is generally caused by air in the hydraulic system. Bleed and adjust the brakes as described in Chapter Sixteen.

Brake Drag

Check brake adjustment. Check for insufficient brake pedal and/or hand lever free play. Also check for worn, loose or missing parts in the brake calipers. Check the brake disc for warp or excessive runout.

Brakes Squeal or Chatter

Check brake pad thickness and disc condition. Make sure that the pads are not loose. Check that the anti-rattle springs are properly installed and in good condition. Clean off any dirt on the pads. Loose components can also cause this. Check for:

1. Warped brake disc.
2. Loose brake disc.
3. Loose caliper mounting bolts.
4. Loose front axle nut.
5. Worn wheel bearings.
6. Damaged hub.

Table 1 and Table 2 are on the following page.

Table 1 STARTER SPECIFICATIONS

| | |
|--------------------------------------|--------------|
| Current draw | |
| Normal | 160-200 amps |
| Maximum | 250 amps |
| Maximum no-load current @ 11.5 volts | 90 amps |
| Minimum no-load speed @ 11.5 volts | 3000 rpm |

Table 2 ELECTRICAL SPECIFICATIONS

| | |
|---|------------------------------|
| Alternator | |
| Stator coil resistance | 0.2-0.4 ohms |
| AC voltage output | 19-26 Vac per 1000 rpm |
| Battery capacity | 12 volt, 19 amp hr. |
| Ignition coil | |
| Primary resistance | |
| 1200S models | 0.4-0.6 ohms |
| All other models | 2.5-3.1 ohms |
| Secondary resistance | |
| 1986-1992 models | 11,250-13,750 ohms |
| 1993-2003 models | |
| 1200S models | 11,700-12,700 ohms |
| All other models | 10,000-12,500 ohms |
| Spark plug cable resistance (1998-2003 1200S) | |
| Front left cable (No. 1) | 5039-11,758 ohms |
| Rear center cable (No.2) | 4665-10,886 ohms |
| Rear left cable (No. 3) | 5787-13,504 ohms |
| Front center cable (No. 4) | 4882-11,392 ohms |
| Voltage regulator | |
| Voltage output | |
| 1986-1993 models | 13.8-15 VDC @ 75° F (24° C) |
| 1994-2003 models | 14.3-14.7 VDC @75° F (24° C) |
| Amps @ 3600 rpm | |
| 1986-1990 models | 19 amps |
| 1991-2003 models | 22 amps |

LUBRICATION, MAINTENANCE AND TUNE-UP

This chapter covers lubrication, maintenance and tune-up procedures.

To maximize the service life of the motorcycle, and gain maximum safety and performance, it is necessary to perform periodic inspections and maintenance. Minor problems found during routine service can be corrected before they develop into major ones.

Consider the maintenance schedule a guide. Harder than normal use and exposure to mud, water or high humidity indicates the need for more frequent servicing of most maintenance items. Record all service and repairs in the maintenance log at the back of this manual. A running record will make it easier to evaluate future maintenance requirements and maintain the motorcycle in top condition.

Maintenance intervals, capacities, recommendations and specification are listed in **Tables 1-9** at the end of this chapter.

FUEL TYPE

The recommended pump octane number is 89 or higher for 1986-1990 models and 87 or higher for 1991-2003 models. Using fuel with a lower octane number can cause pinging or spark knock, and lead to engine damage.

When choosing gasoline and filling the fuel tank, note the following:

1. When filling the tank, do not overfill it. There should be no fuel in the filler neck (tube located between the fuel cap and tank).
2. Because oxygenated fuels can damage plastic and paint, do not spill fuel onto the fuel tank during filling.
3. DO NOT use gasoline containing methanol (methyl or wood alcohol).
4. DO NOT use gasoline containing more than 10% of ethanol (ethyl or grain alcohol).

MAINTENANCE SCHEDULE

Refer to **Table 1** for a recommended maintenance schedule. If the motorcycle is operated under extreme conditions, perform the appropriate maintenance more frequently.

Most of the services in **Table 1** are described in this chapter. However, some procedures, which require more than minor disassembly or adjustment, are covered in the appropriate chapter.

ROUTINE SAFETY CHECKS

Pre-ride Inspection

1. Check wheel and tire condition. Check tire pressure. Refer to *Tires and Wheels* in this chapter.

2. Make sure all lights work. Refer to the *Lights and Horn* section.
3. Check engine, transmission and primary drive chaincase for oil leaks. If necessary, add oil as described in this chapter.
4. Check brake fluid level and condition. If necessary, add fluid as described in this chapter.
5. Check the operation of the front and rear brakes.
6. Check clutch operation. If necessary, adjust the clutch as described in this chapter.
7. Check the throttle operation. The throttle should move smoothly and return quickly when released. If necessary, adjust throttle free play as described in this chapter.
8. Inspect the front and rear suspension. They should have a solid feel with no looseness.
9. Check the exhaust system for leaks or damage.
10. Inspect the fuel system for leaks.
11. Check the fuel level in fuel tank.
12. If equipped with a drive chain, check chain free play as described in this chapter.
13. If equipped with a drive belt, check drive belt tension as described in this chapter.

CAUTION

When checking the tightness of the exposed fasteners, do not check the cylinder head bolts without following the procedure described in Chapter Four.

14. Check the tightness of exposed fasteners.

Lights and Horn

Turn the ignition switch on, and check the following:

1. Pull the front brake lever and make sure the brake light works.
2. Push the rear brake pedal down and verify the brake light operation.
3. Make sure the headlight and taillight work.
4. Move the dimmer switch between the high and low positions, and make sure both headlight elements are working.
5. Push the turn signal switch to the left and right positions, and make sure all four turn signal lights are working.
6. Make sure all accessory lights work properly, if so equipped.
7. Check the horn button operation.
8. If the horn or any light fails to work properly, refer to Chapter Twelve.

TIRES AND WHEELS

Tire Pressure

Check the tire pressure often to maintain tire profile, traction and handling, and to get the maximum life out of the tire. Carry a tire gauge in the motorcycle's tool kit. **Table 2** lists the cold tire pressures for the original equipment tires.

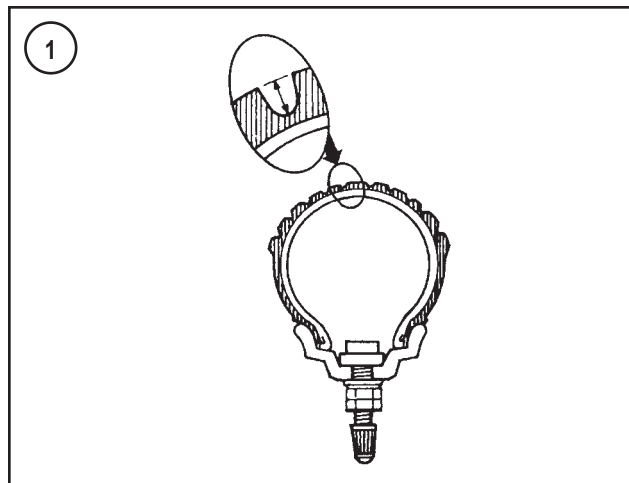

NOTE

Always reinstall the air valve caps after checking and adjusting the air pressure. These caps prevent debris from collecting in the valve stems and causing air leaks or incorrect tire pressure readings.

Tire Inspection

Inspect the tires periodically for excessive wear, deep cuts and imbedded objects such as stones or nails. If a nail or other object is found in a tire, mark its location with a light crayon prior to removing it. This will help locate the hole for repair.

Measure the tread depth (**Figure 1**) with a gauge or a small ruler. As a guideline, replace tires when the tread depth is 1/16 in. (1.6 mm.) or less. On original equipment tires, wear bars on the tire will first appear flush with the surrounding rubber when wear depth reaches 1/32 in. (0.8 mm). Replace the tire before wear reaches the wear bars. Refer to Chapter Thirteen for tire changing and repair information.

Laced Wheel Spoke Tension

On models with laced wheels, check for loose or damaged spokes. Refer to Chapter Thirteen for wheel service.

Rim Inspection

Check the rims for cracks and other damage. Refer to Chapter Thirteen for wheel service.

PERIODIC LUBRICATION

NOTE

Never dispose of oil in the trash, on the ground or down a storm drain. Many service stations and oil retailers accept used oil for

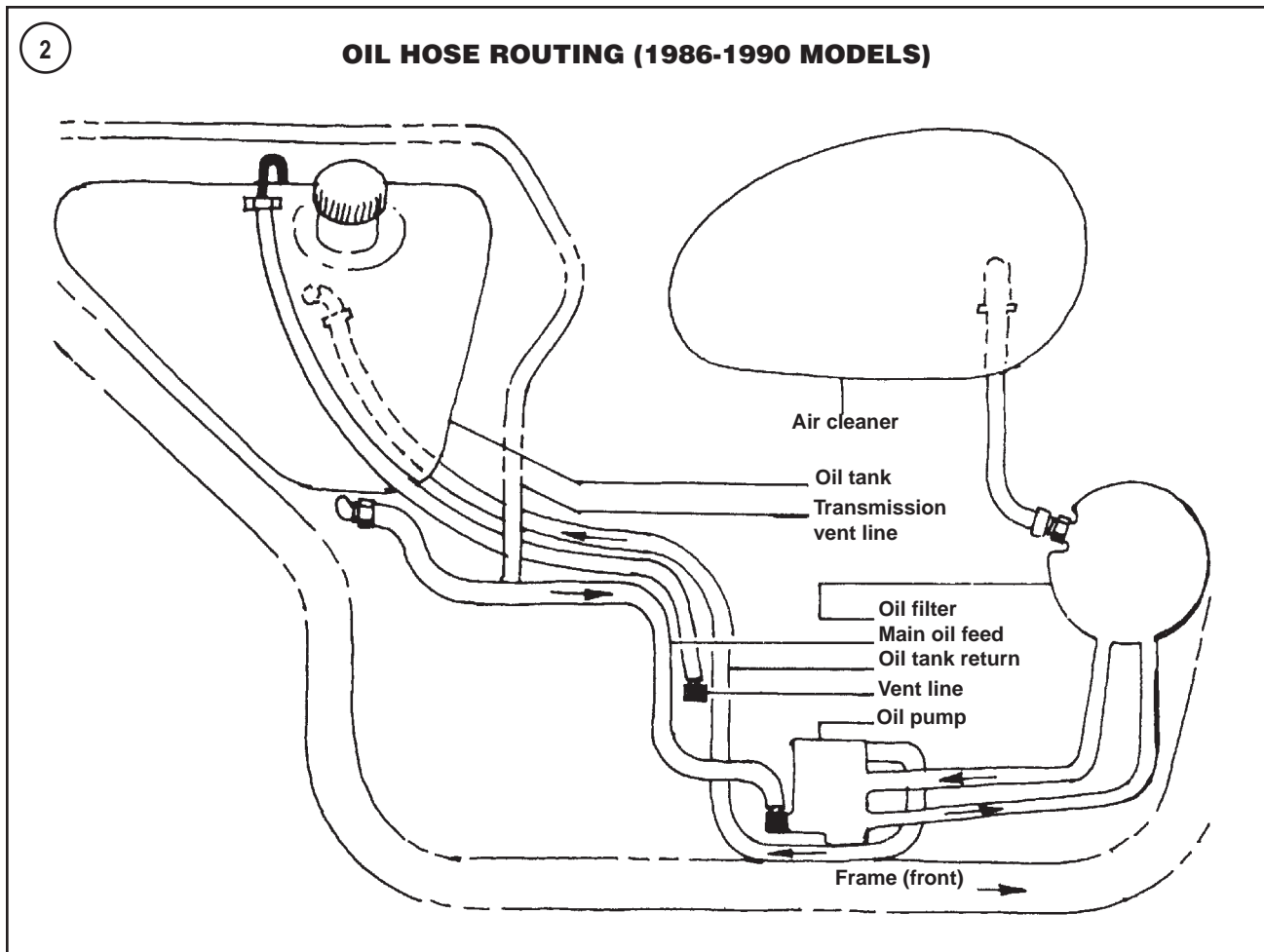

recycling. Do not combine other fluids with motor oil to be recycled.

Oil Tank and Oil Line Inspection

Before inspecting the oil level, inspect the oil tank for cracks or other damage. If oil leaks are evident on or near the oil tank, locate and repair the problem. Check the oil tank mounting bolts for loose or missing fasteners; replace or tighten all fasteners. Check all oil line connections on the tank and the engine crankcase (**Figures 2-4**). Replace damaged oil lines as described in *Oil Tank* in Chapter Four.

Engine Oil Level Check

1. Run the engine until normal operating temperature is reached. Stop the engine and allow the oil to settle in the oil tank.

CAUTION

Allowing the motorcycle to rest on the sidestand will result in an incorrect oil level reading.

2. Place the motorcycle on a level surface and hold the motorcycle upright so it is not resting on the sidestand.
3. Wipe the area around the oil filler cap (**Figure 5**) with a clean rag. Remove the cap by pulling it up.
4. Wipe the dipstick with a clean rag, then reinstall the oil filler cap. Be sure the cap is fully seated.
5. Remove the filler cap and check the oil level on the dipstick (**Figure 6**). The oil level should be between the full (upper) and fill (lower) indicator grooves on the dipstick (**Figure 7**). If the oil level is even with or below the fill groove, continue with Step 6. If the oil level is correct, go to Step 7.
6. Add the recommended engine oil listed in **Table 3**.

CAUTION

Do not overfill the oil level in the oil tank. If the engine is cold, do not add oil so oil level reaches the full groove. Oil may be forced into the air cleaner causing engine malfunction or damage.

7. Inspect the oil filler cap O-ring for cracks or other damage. Replace the O-ring if necessary.
8. Reinstall the oil filler cap. Be sure the cap is fully seated.

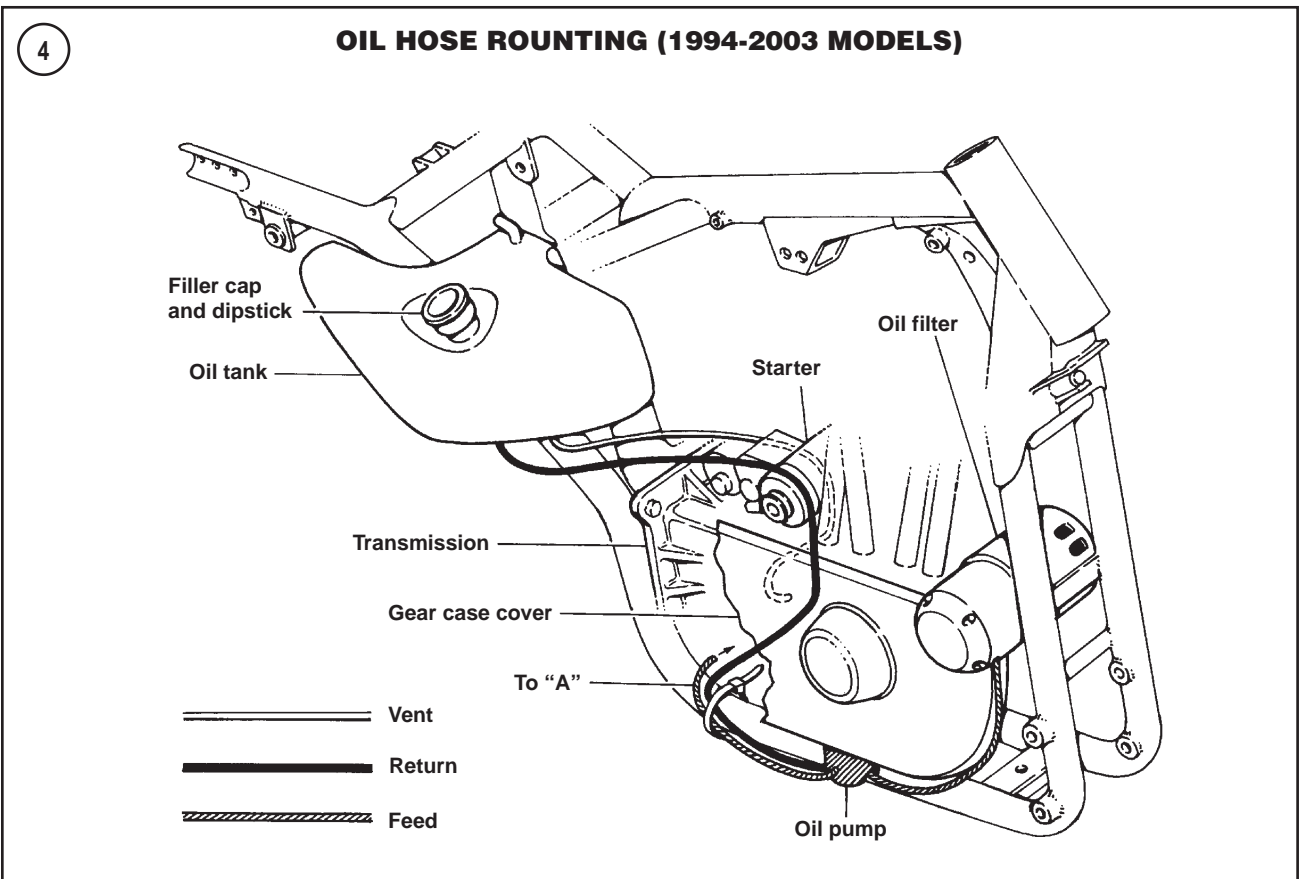
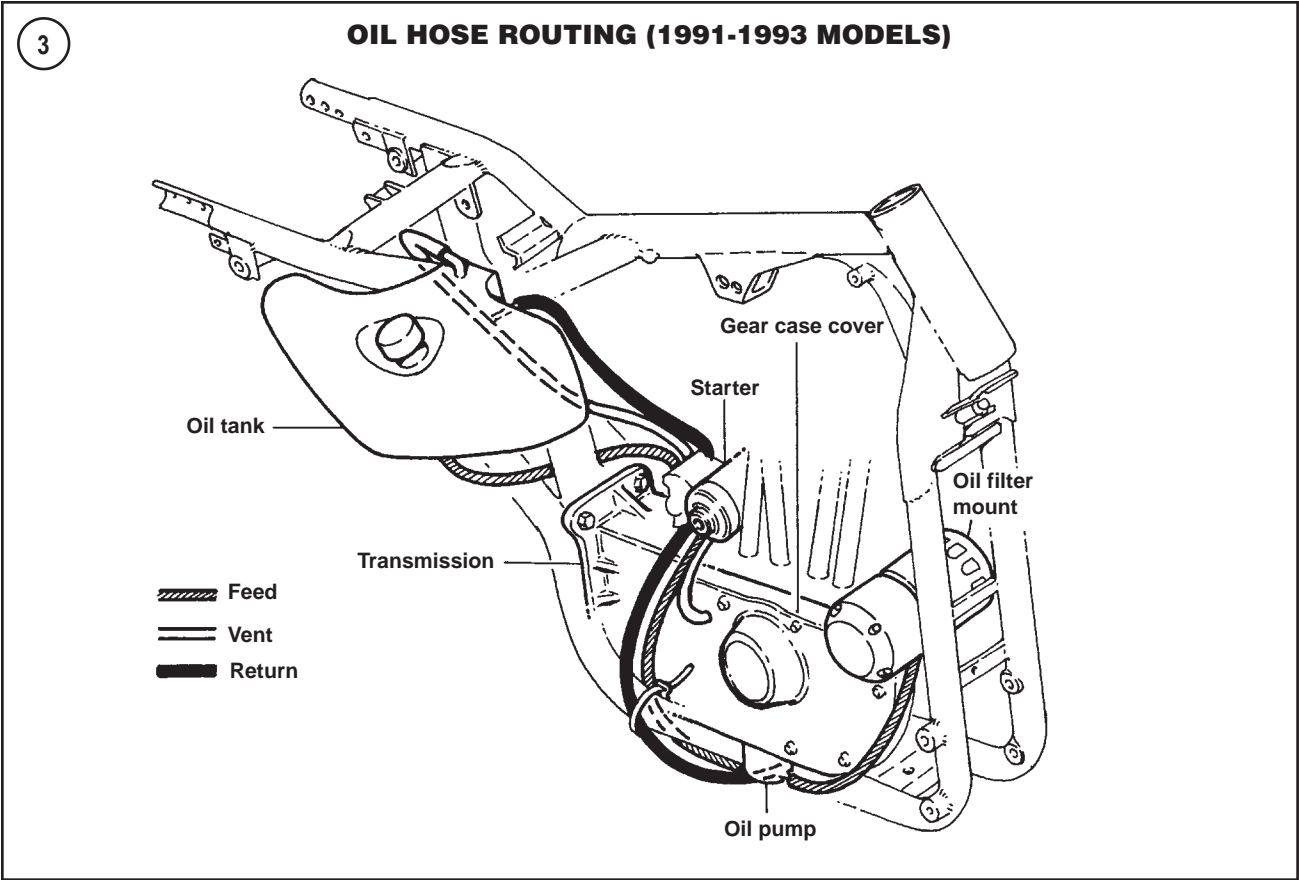

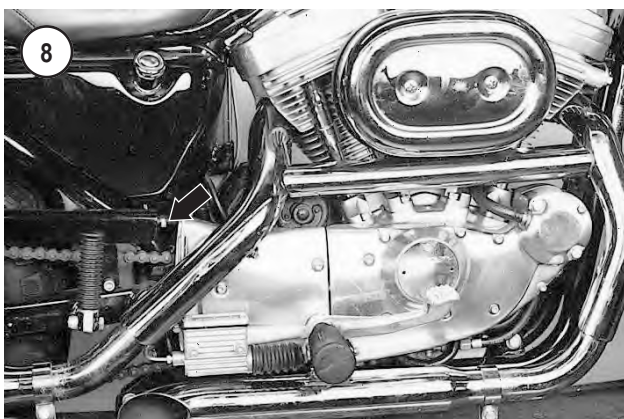
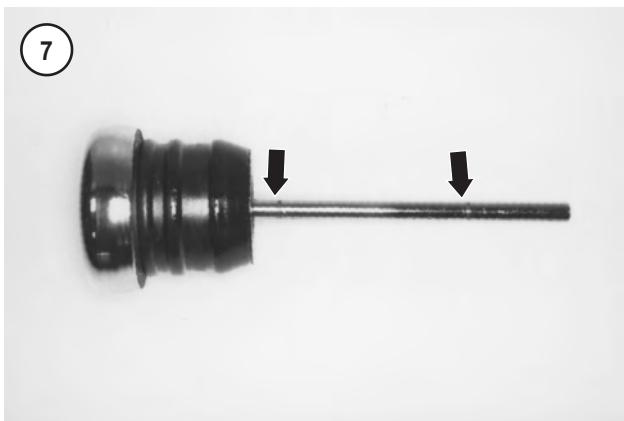

Engine Oil and Filter Change

Table 1 lists the recommended oil and filter change intervals for motorcycles operated in moderate climates. If the motorcycle is operated in heavy dust, mud, water or other conditions, the oil should be changed more frequently.

The manufacturer recommends using Harley-Davidson oils. If not available, the manufacturer recommends using oil certified for use in diesel engines. Acceptable certifications include: CF-4, CG-4, CH-4 and CI-4. Follow the viscosity recommendations applicable to Harley-Davidson oil.

Always use the same brand of oil at each change. Refer to **Table 3** for the correct oil viscosity to use in anticipated ambient temperatures, not engine oil temperature. Using oil additives is not recommended as they may cause the clutch to slip.

WARNING

Contact with oil may cause skin cancer. Wash oil from hands with soap and water as soon as possible after handling engine oil.

CAUTION

Do not use the current SH and SJ rated automotive oils in motorcycle engines. The SH and SJ rated oils contain friction modifiers that reduce frictional losses on engine components. Specifically designed for automotive engines, these oils can damage motorcycle engines and clutches.

1. Run the motorcycle until the engine has reached normal operating temperature. Turn the engine off and allow the oil to settle in the oil tank. Support the motorcycle so that the oil can drain completely.
2. Wipe the area around the oil filler cap (**Figure 5**) with a clean rag. Remove the cap by pulling up.
3. Locate the oil drain hose.
 - a. On 1986-1990 models, the oil drain hose extends from the bottom of the oil tank (**Figure 8**).
 - b. On 1991-1993 models, the drain hose (**Figure 9**) is secured to the battery tray lug on the left side of the motorcycle.
 - c. On 1994-2003 models, the drain hose is secured to a lug on the rear muffler mount on the left side of the motorcycle (**Figure 10**).

4. Place a drain pan underneath the oil tank drain line.
5. Detach the hose clamp, then direct the hose end into the drain pan.
6. Allow the oil to drain completely. Remove the oil tank filler cap (**Figure 5**) for faster oil flow.
7. Reattach the oil drain hose and clamp.
8. To replace the oil filter, perform the following:
 - a. Place a drain pan underneath the front portion of the crankcase and the oil filter.
 - b. Install a suitable oil filter wrench (**Figure 11**) squarely onto the oil filter and loosen it counterclockwise. Quickly remove the oil filter as oil will begin to run out of it.
 - c. Hold the filter over the drain pan and pour out the remaining oil. Place the filter in a plastic bag, seal the bag and dispose of it properly.
 - d. Wipe off all oil that drained onto the engine. Clean with a contact cleaner to eliminate all oil residue from the engine prior to installing the new oil filter.
 - e. Pour approximately 4 oz. (120 ml) of new engine oil into the new oil filter. Allow the oil to soak into the filter element.
 - f. Coat the gasket on the new filter (**Figure 12**) with clean oil.

CAUTION

Tighten the oil filter by hand. Do not overtighten.

- g. Screw the oil filter onto the mounting pad by hand and tighten it until the filter gasket touches the sealing surface, then tighten the filter by hand an additional 1/2 to 3/4 turn.

CAUTION

Do not overfill the oil tank. Oil may be forced into the air cleaner causing engine malfunction or damage.

9. Add the correct viscosity (**Table 3**) and quantity (**Table 4**) of oil to the oil tank—minus the 4 oz. (120 ml) poured into the oil filter.

CAUTION

On 1994-2003 models, perform Step 10 to prevent oil pump cavitation.

10. On 1994-2003 models, remove air from the oil tank drain hose using the following procedure:
 - a. Place a drain pan under the oil tank drain hose.
 - b. Detach the hose clamp, then direct the hose end into the drain pan.
 - c. Allow a small amount of oil to drain out of the hose.
 - d. Reattach the oil drain hose and clamp.
11. Install the oil tank filler cap.
12. Run the engine at idle speed. The oil pressure warning light should go out when engine speed is 1000 rpm or higher. If not, shut off the engine and determine the cause.

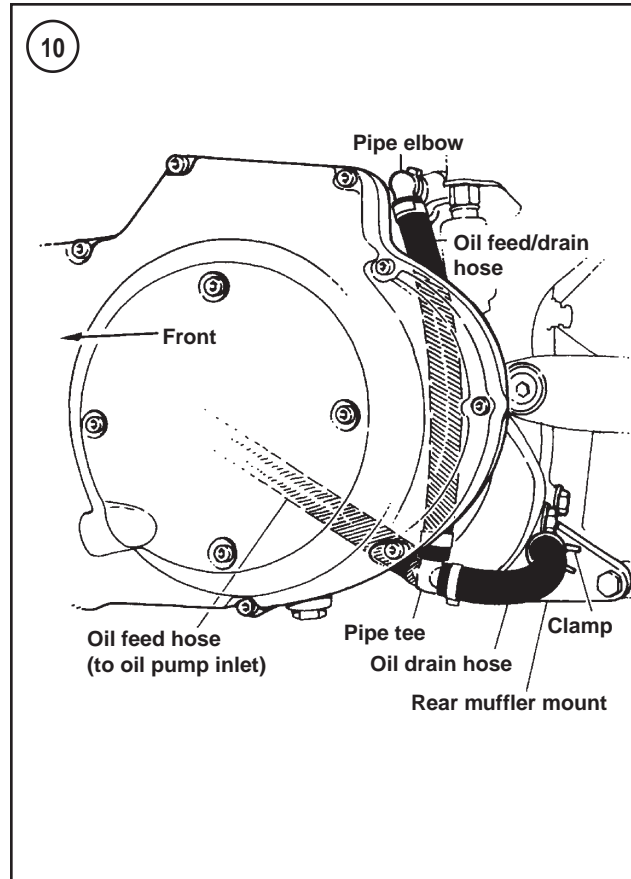

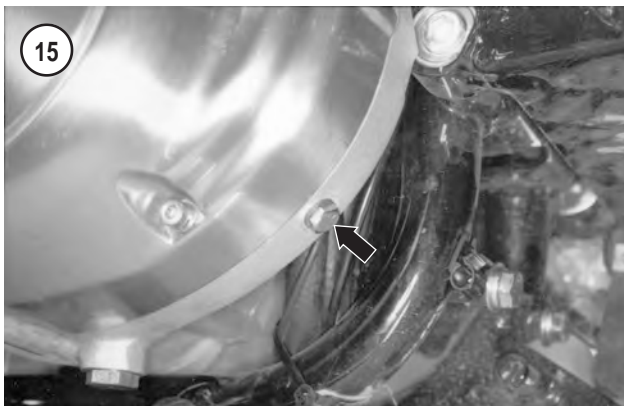
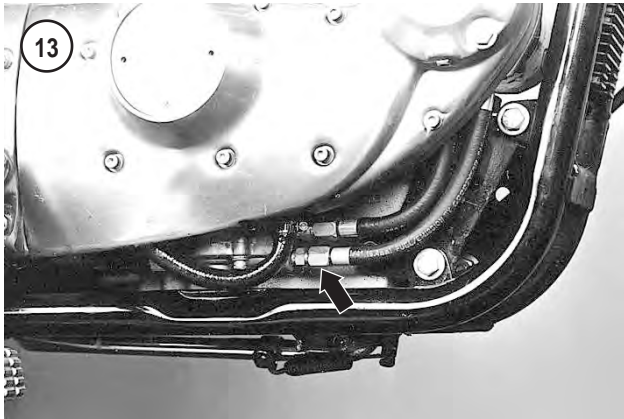

On 1986-1990 models, if the warning light remains on perform the following:

- a. Stop the engine.
 - b. Remove the oil tank filler cap.
 - c. Loosen the lower, front oil pump hose fitting (**Figure 13**) and allow 2 oz. (60 ml) of oil to drain out.
 - d. Tighten the fitting and install the oil tank filler cap.
 - e. Run the engine to verify the warning light goes out.
13. Check for oil leaks, particularly at the oil filter and drain hose.
 14. Stop the engine.
 15. Check the oil level on the dipstick as described in this section.
 16. Properly dispose of the used oil.

Transmission Oil

CAUTION

*Do not fill the transmission with engine oil. Only add the recommended transmission oil in **Table 5**. Overfilling may cause clutch malfunctioning.*

The transmission oil also lubricates the clutch, primary drive chain and sprockets.

Table 1 lists the recommended transmission oil inspection intervals. When checking the transmission oil level, do not allow any dirt or debris to enter the transmission case opening.

Oil level check (1986-1990 models)

1. If the motorcycle has been operated recently, wait approximately ten minutes before checking the oil to allow the oil to settle in the case. Park the motorcycle on a level surface and have an assistant support it so that it is standing straight up.

CAUTION

Do not check the oil level with the motorcycle supported on the sidestand or the reading will be incorrect.

2. Place a drain pan beneath the primary chain cover.
3. Remove the oil level plug from the bottom of the cover (**A, Figure 14**).
4. Oil should seep from the plug hole. If not, remove the access cover from the top of the primary chain cover (**B, Figure 14**). Slowly add the recommended oil (**Table 5**) through the access cover hole until oil begins to run out of the oil level plug hole. When the oil just seeps out of the hole, install the oil level plug.
5. Install the access cover (**B, Figure 14**).

Oil level check (1991-1993 models)

1. If the motorcycle has been operated recently, wait approximately ten minutes before checking the oil to allow the oil to settle in the case. Park the motorcycle on a level surface and have an assistant support it so that it is standing straight up.

CAUTION

Do not check the oil level with the motorcycle supported on the sidestand or the reading will be incorrect.

2. Place a drain pan beneath the primary chain cover.
3. Remove the oil level plug from the bottom, rear of the cover (**Figure 15**).

- Oil should seep from the plug hole. If not, remove the access cover from the primary chain cover (**Figure 16**). Slowly add the recommended oil (**Table 5**) through the access cover hole until oil begins to run out of the oil level plug hole. When the oil just seeps out of the hole, install the oil level plug.
- Install the access cover (**Figure 16**).

Oil level check (1994-2003 models)

- If the motorcycle has been operated recently, wait approximately ten minutes before checking the oil to allow the oil to settle in the case. Park the motorcycle on a level surface and have an assistant support it so that it is standing straight up.

CAUTION

Do not check the oil level with the motorcycle supported on the sidestand or the reading will be incorrect.

- Clean the area around the clutch inspection cover (**Figure 17**).

NOTE

If a suitable tool is not available to remove the lower, left cover screw, remove the footrest (Chapter Sixteen).

- Remove the clutch inspection cover retaining screws, then remove the cover.

NOTE

*The primary drive cover is removed in **Figure 18** for clarity. It is not necessary to remove the cover.*

- Check the transmission oil level through the primary drive cover opening (A, **Figure 19**). It should be even with the bottom of the clutch diaphragm spring (**Figure 18**).
- If the oil level is low, add the recommended type of transmission oil listed in **Table 5**. Do not overfill.
- Be sure the quad ring is located in the primary drive cover groove (B, **Figure 19**).
- Install the inspection cover so the notch in the cover (**Figure 20**) fits over the cable boss (C, **Figure 19**) on the primary drive cover. Tighten the primary drive cover retaining screws to 84-108 in.-lb. (10-12.0 N•m).

Transmission oil change (1986-1993 models)

Table 1 lists the recommended transmission oil change intervals.

- Ride the motorcycle for approximately ten minutes and shift through all five gears until the transmission oil has reached normal operating temperature. Turn off the engine

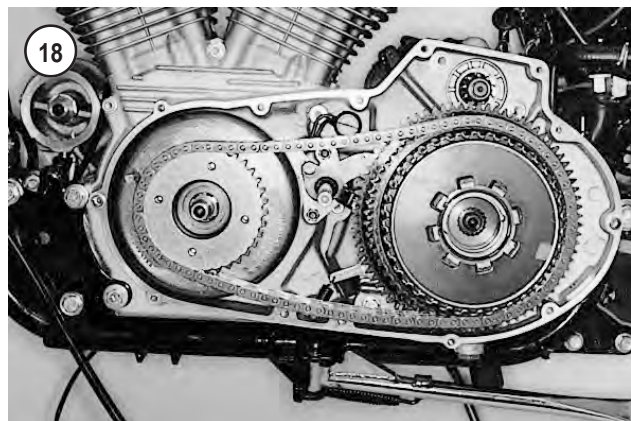
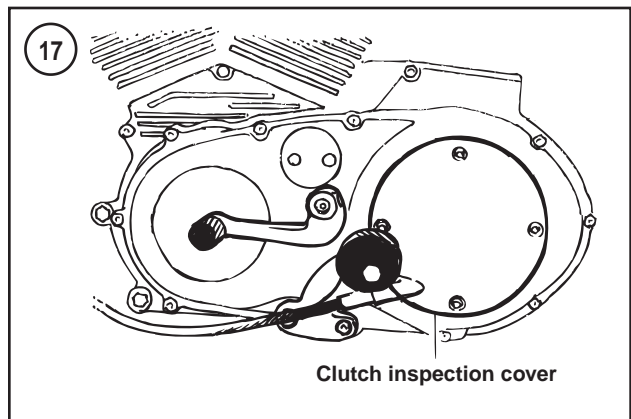
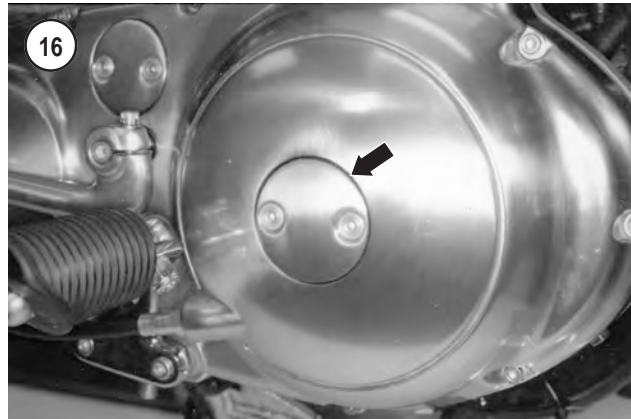

and allow the oil to settle in the case. Park the motorcycle on a level surface and have an assistant support it so that it is standing straight up.

- Place a drain pan underneath the engine and remove the oil drain plug (**Figure 21**).
- Inspect the drain plug O-ring (**Figure 22**) for damage and replace it if necessary.
- The drain plug is magnetic. Check the plug for metal debris that may indicate transmission damage, then wipe off the plug. Replace the plug if it is damaged.
- Install the drain plug and O-ring and tighten to 14-21 ft.-lb. (19-28 N•m).

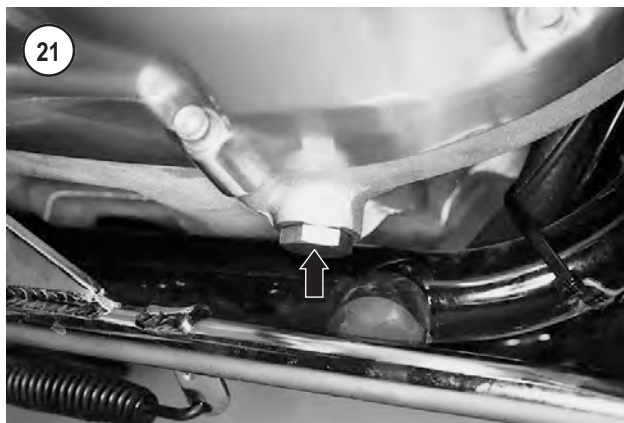
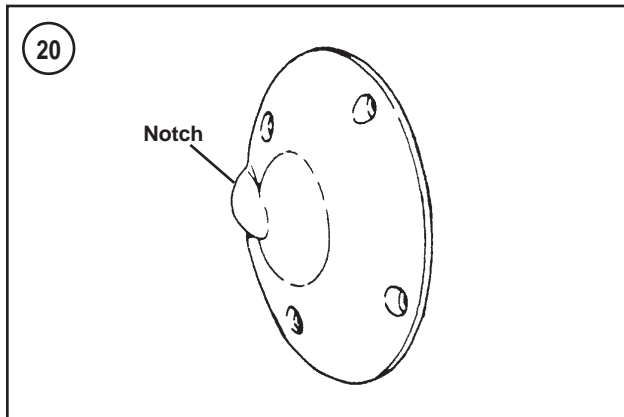

6A. On 1986-1990 models, remove the access cover (B, **Figure 14**) and refill with the recommended quantity (**Table 4**) and type (**Table 5**) transmission oil.

6B. On 1991-1993 models, remove the inspection cover (**Figure 16**) and refill with the recommended quantity (**Table 4**) and type (**Table 5**) transmission oil.

7. Check the oil level as described in this section.

Transmission oil change (1994-2003 models)

Table 1 lists the recommended transmission oil change intervals.

1. Ride the motorcycle for approximately ten minutes and shift through all five gears until the transmission oil has reached normal operating temperature. Turn off the engine and allow the oil to settle in the case. Park the motorcycle on a level surface and have an assistant support it so that it is standing straight up.

2. Place a drain pan underneath the engine and remove the oil drain plug (**Figure 21**).

3. Inspect the drain plug O-ring (**Figure 22**) for damage and replace it if necessary.

4. The drain plug is magnetic. Check the plug for metal debris that may indicate transmission damage, then wipe off the plug. Replace the plug if it is damaged.

5. Install the drain plug and O-ring and tighten to 14-21 ft.-lb. (19-28 N•m).

6. Clean the area around the clutch inspection cover (**Figure 17**).

7. Remove the clutch inspection cover retaining screws, then remove the cover (**Figure 17**).

NOTE

*The primary drive cover is removed in **Figure 18** for clarity. It is not necessary to remove the cover.*

8. Refill the transmission through the opening in the primary drive cover with the recommended quantity (**Table 4**) and type (**Table 5**) of transmission oil. The transmission oil level should be even with the bottom of the clutch diaphragm spring (**Figure 19**).

9. Install the clutch inspection cover. Tighten the retaining screws to 84-108 in.-lb. (10-12.0 N•m).

10. Check the oil level as described in this section.

Fork Oil Change

This procedure is for a fork oil change. If the fork has been disassembled for service, refer to Chapter Fourteen for fork oil refilling and specifications.

Table 1 lists the recommended fork oil change intervals.

CAUTION

Do not allow the fork oil to come in contact with the brake components.

1. Place a drain pan beside one fork tube, then remove the drain screw (**Figure 23**) from the slider.
2. Straddle the motorcycle and apply the front brake lever. Push down on the fork and release. Repeat to force as much oil out of the fork tube and slider as possible.
3. Repeat Steps 1-2 for the opposite fork tube.
4. After the fork oil has thoroughly drained, install the drain screw (**Figure 23**) onto the fork slider. Tighten the drain screw securely.
5. Support the front of the motorcycle so the front wheel is off the ground.

WARNING

The fork cap is under spring pressure and may fly off when loosening it. In addition, make sure the fork tube is fully extended from the slider. If the fork is damaged and stuck in a compressed state, the fork should be disassembled by a dealer; as the fork cap and spring will fly out from the fork tube under considerable force when the cap is removed.

CAUTION

Use only a 6-point socket to loosen and tighten the fork tube cap to avoid cosmetic damage to the fork tube cap. Using a 12-point socket may round off the corners of the fork tube cap.

6. Remove the fork cap from the top of the fork tube (**Figure 24**).
7. Refill each fork leg with the correct viscosity (**Table 5**) and quantity of fork oil (**Table 6**).
8. Repeat Step 6 and Step 7 for the opposite fork tube.
9. Replace the fork cap O-ring (**Figure 25**, typical) if leaking, excessively worn or damaged.

NOTE

It takes considerable pressure to push the fork cap down against spring pressure while turning it.

10. Attach a suitable socket to a speed wrench, then push down on the speed wrench to turn the fork cap. It may be necessary to move aside the handlebar and lower handlebar holder (Chapter Fourteen) so the socket will fit properly on the fork cap. A fork spring compression kit is available from Motion Pro.
11. Install the fork cap (**Figure 24**) onto the top of the fork tube. Tighten the fork cap securely.
12. Road test the motorcycle and check for leaks.

Control Cables (Non-Nylon Lined Cables)

Lubricate the control cables with a cable lubricant at the intervals in **Table 1**, or when they become stiff or sluggish. When lubricating the control cables, inspect each cable for fraying and cable sheath damage. Replace damaged cables.

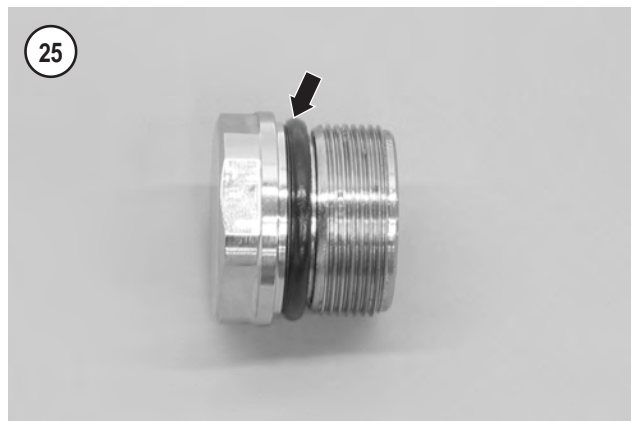

CAUTION

If the original equipment cables have been replaced with nylon-lined cables, do not lubricate them as described in this procedure. Oil and most cable lubricants will cause the cable liner to expand, pushing the liner against the cable sheath. Nylon-lined cables are normally used dry. When servicing nylon-lined and other aftermarket cables, follow the manufacturer's instructions.

CAUTION

Do not use chain lubricant to lubricate control cables.

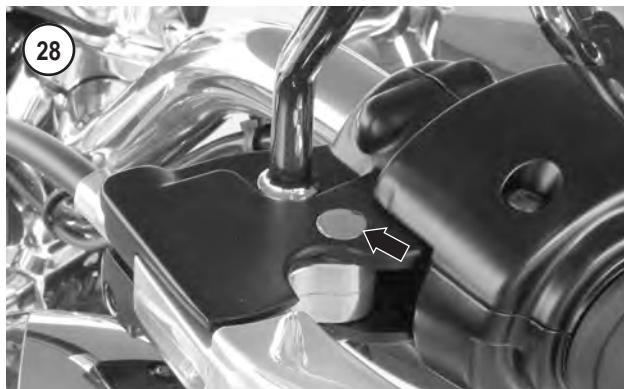

CAUTION

The starting enrichment valve (choke) cable is designed to operate with a certain amount of cable resistance. Do not lubricate the enrichment cable or its conduit.

- 1A. Disconnect the clutch cable ends as described in *Clutch Cable* in Chapter Six or Chapter Seven.
- 1B. Disconnect both throttle cable ends as described in the *Throttle and Idle Cables* in Chapter Ten or Chapter Eleven.
2. Attach a lubricator tool (**Figure 26**) to the cable following the tool manufacturer's instructions. Place a shop cloth at the end of the cable to catch excess lubricant.
3. Apply lubricant until it begins to flow out of the other end of the cable. If the lubricant squirts out from around the

lubricator, it is not clamped to the cable properly. Loosen and reposition the cable lubricator.

CAUTION

If the lubricant does not flow out of the other end of the cable, check the cable for fraying, bending or other damage. Replace damaged cables.

4. Remove the lubricator tool and wipe off both ends of the cable.
- 5A. Reconnect the clutch cable ends as described in *Clutch Cable* in Chapter Six or Chapter Seven.
- 5B. Reconnect both throttle cable ends as described in *Throttle and Idle Cable* in Chapter Ten or Chapter Eleven.
6. Adjust the cables as described in this chapter.

Throttle Control Grip Lubrication

Table 1 lists the recommended throttle control grip lubrication intervals. To remove and install the throttle grip, refer to the *Throttle and Idle Cable Replacement* section in Chapter Ten or Chapter Eleven. Lubricate the throttle control grip where it contacts the handlebar with graphite.

Front Brake Lever Pivot Pin Lubrication

Inspect the front brake lever pivot pin (**Figure 27**) at the intervals in **Table 1**. If the pin is dry, lubricate it with a lightweight oil. To service the pivot pin, refer to the *Front Master Cylinder* section in Chapter Sixteen.

Clutch Lever Pivot Pin Lubrication

Inspect the clutch lever pivot pin (**Figure 28**) at the intervals in **Table 1**. Lubricate the pin with a lightweight oil. To service the pivot pin, refer to the *Clutch Cable Replacement* in Chapter Six or Chapter Seven.

Drive Chain Lubrication

Lubricate the drive chain on appropriate models so equipped at the interval indicated in **Table 1**.

1. The manufacturer recommends the following lubricants depending on the chain type:
 - a. On models equipped with a standard drive chain, use H-D Chain Spray or H-D High-Performance Chain Lube.
 - b. On models equipped with an O-ring drive chain, use H-D High-Performance Chain Lube or an automotive lubricant rated API GL-5 with a viscosity index of SAE 80 or 90.

NOTE

On an O-ring type drive chain, the chain lubrication described in this procedure is used mainly to keep the O-rings pliable and to pre-

vent the side plates and rollers from rusting. The actual chain lubrication is enclosed within the chain by the O-rings.

2. Ride the motorcycle a few miles to warm the drive chain. A warm chain increases lubricant penetration.
3. Park the motorcycle on level ground. Support the motorcycle securely on a swing arm stand with the rear wheel off the ground.
4. Oil the bottom chain (**Figure 29**) with a suitable chain lubricant. Concentrate on getting the oil down between the side plates on both sides of the chain. Do not over lubricate.
5. Rotate the chain and continue lubricating until the entire chain has been covered.
6. Turn the rear wheel slowly and wipe off excess oil from the chain. Also wipe off lubricant from the rear hub, wheel and tire.
7. Remove the auxiliary stand.

Sidestand Lubrication

Refer to **Table 1** for the specified lubrication interval for the sidestand. Lubricate the bushings using wheel bearing grease, then reassemble the sidestand. Refer to Chapter Seventeen

Steering Head Lubrication

Refer to **Table 1** for the specified lubrication interval for the steering head bearings. Refer to Chapter Fourteen and disassemble the steering head as needed for access to the bearings. Lubricate the bearings using wheel bearing grease, then reassemble the steering head.

Speedometer Cable Lubrication (1986-1994 Models)

Lubricate the cable annually or whenever the speedometer needle operates erratically.

1. Disconnect the speedometer fitting from the back of the speedometer (**Figure 30**).
2. Pull the cable from the cable housing.
3. Clean off the old lubricant.
4. Apply speedometer cable lubricant to the cable.
5. Install the cable into the housing. Turn the cable so it engages the drive unit at the lower end. When the cable stops turning, the lower end is properly engaged.
6. Reconnect the upper end to the speedometer.

PERIODIC MAINTENANCE

Perform the services listed at the intervals in **Table 1**. If the motorcycle is exposed to harsh condition, perform the services more frequently.

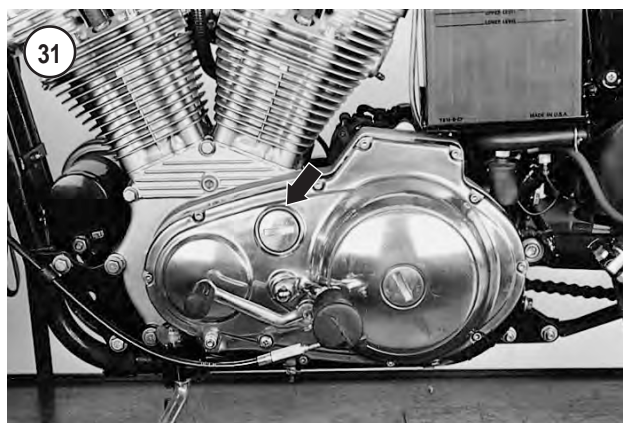

Primary Chain Adjustment

1. Disconnect the negative battery cable as described in Chapter Twelve.
2. Support the motorcycle on a stand or floor jack with the rear wheel off the ground. Refer to *Motorcycle Stands* in Chapter Thirteen.
- 3A. On 1986-1990 models, unscrew the primary chain inspection cover (**Figure 31**).
- 3B. On 1991-2003 models, remove the retaining bolts, then remove the primary chain inspection cover (**Figure 32**).
4. Turn the primary chain to find the tightest point on the chain. Measure chain free play at this point.

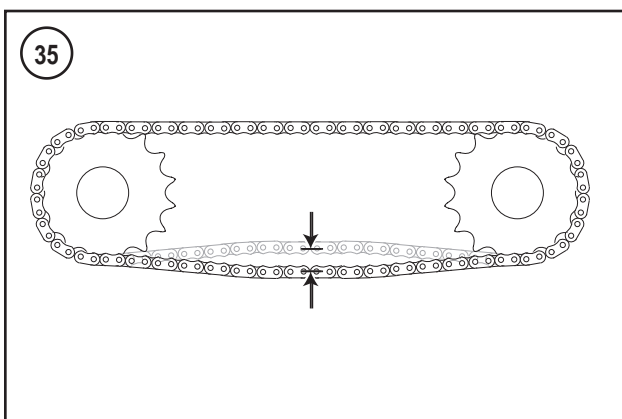
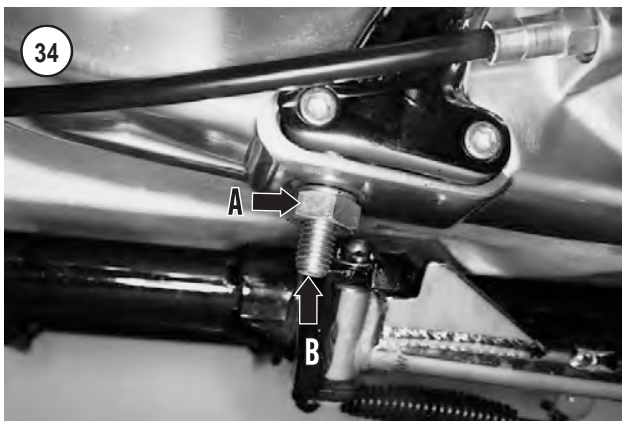

5. Check primary chain free play at the upper chain run midway between the sprockets (**Figure 33**). If the primary chain free play is incorrect, continue with Step 6. If the free play is correct, go to Step 7. The primary chain free play specifications are:

- a. Cold engine: 3/8-1/2 in. (9.6-12.7 mm).
- b. Hot engine: 1/4-3/8 in. (6.4-9.6 mm).

6. To adjust the chain, perform the following:

- a. Loosen the primary chain adjuster locknut (A, **Figure 34**, typical).
- b. Rotate the adjuster (B, **Figure 34**) to obtain the desired chain free play.
- c. Tighten the primary chain adjuster locknut (A, **Figure 34**) to 98-144 in.-lb. (10.8-16.3 N•m) on 1986-1990 models or 20-25 ft.-lb. (28-34 N•m) on 1991-2003 models.
- d. Recheck free play.

NOTE

If specified primary chain free play cannot be obtained using the adjuster, the primary chain or adjuster mechanism is excessively worn and should be removed for inspection. Refer to Chapter Six or Chapter Seven.

7. Reinstall the primary chain inspection cover and O-ring.
8. Lower the motorcycle to the ground.

Drive Chain (Models So Equipped)

Adjustment

Check and adjust the drive chain at the intervals specified in **Table 1**. If the motorcycle is operated at sustained high speeds or if it is repeatedly accelerated very hard, inspect the drive chain adjustment more often. The correct amount of drive chain free play (**Figure 35**), when pushed up midway on the lower chain run (with the rider seated), is listed in **Table 7**.

When adjusting the chain, check the free play at several places along its length by rotating the rear wheel. The chain rarely wears uniformly and as a result will be tighter at some places than others. Measure the chain free play halfway between the sprockets (**Figure 35**). Make sure the chain free play at the tightest place on the chain is not less than the specification in **Table 7**.

1. Turn the engine off and shift the transmission into neutral.

NOTE

As drive chains stretch and wear, the chain will become tighter at one point. The chain must be checked and adjusted at this point.

2. Turn the rear wheel slowly, then stop it and check the chain tightness. Continue until the tightest point is located. Mark this spot and turn the wheel so that the mark is located on the lower chain run, midway between both drive sprockets.

NOTE

If the drive chain is kinked or feels tight, it may require cleaning and lubrication. Clean and lubricate the primary chain as described in this section.

3. Have a rider on the seat.
4. Push the chain up midway between the sprockets and measure the chain free play (**Figure 35**).
5. If the chain free play is incorrect, adjust it as described in the following steps.
6. On 1989-2003 models, remove and discard the rear axle cotter pin (A, **Figure 36**).
7. Loosen the rear axle nut (B, **Figure 36**).
8. Turn the adjuster locknuts (C, **Figure 36**) on both sides of the wheel. Turn both adjuster nuts an equal number of turns to obtain the correct drive chain free play. Proceed as follows to check wheel alignment.
- 9A. On 1986-1990 models, check rear wheel alignment as follows:
 - a. Sight along the drive chain as it runs over the rear driven sprocket. It should leave the driven sprocket in a straight line as shown in A, **Figure 37**.
 - b. If the drive chain is cocked to one side or the other (B or C, **Figure 37**), turn the adjuster locknuts as needed to obtain a straight chain run and correct chain free play.
- 9B. On 1991 models, check rear wheel alignment as follows:
 - a. Using a suitable metal rod, construct the tool shown in **Figure 38**.
 - b. Insert the end of the tool into the index hole in the swing arm (A, **Figure 39**).
 - c. Slide the rubber grommet along the tool until it aligns with the center of the axle (B, **Figure 39**).
 - d. Check alignment on the opposite side, comparing the rubber grommet position with the center of the axle. The alignment on both sides of the axle must be the same. If necessary, adjust the axle with the axle adjusters, while at the same time maintaining correct drive chain free play.
10. Tighten the rear axle nut to 60-65 ft. (81-88 N•m). On 1989-1991 models install a new rear axle cotter pin (A, **Figure 36**).
11. Tighten the chain adjuster locknuts securely.

Inspection

1. Clean the drive chain as described in this section
2. Park the motorcycle on level ground. Support the motorcycle securely with the rear wheel off the ground.
3. At the rear sprocket, pull one of the links away from the driven sprocket. If the link pulls away more than 1/2 the height of the sprocket tooth (**Figure 40**), the chain is excessively worn.

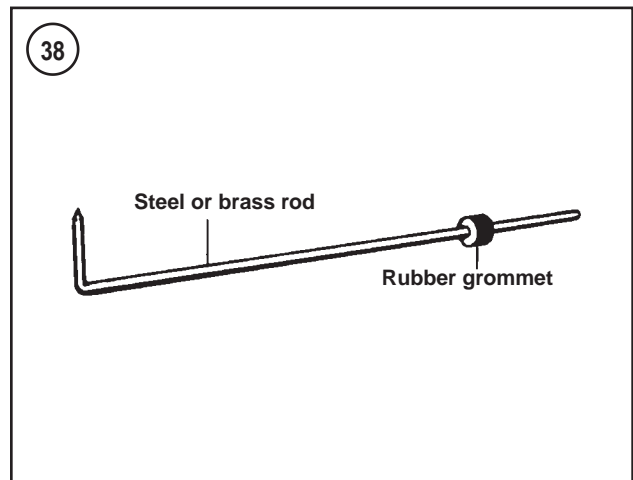
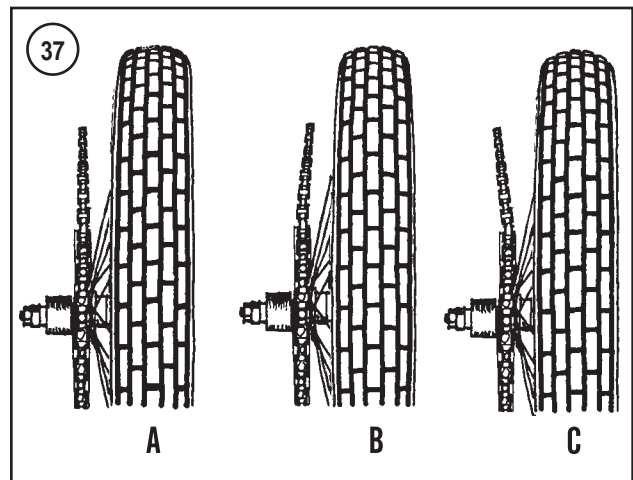
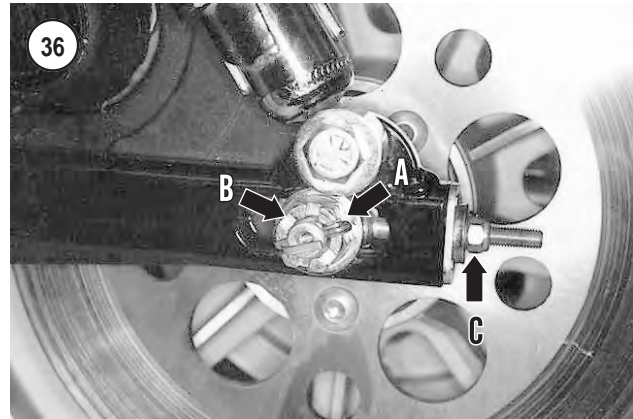

4. Inspect the inner plate chain faces (**Figure 41**). They should be polished on both sides. If they show uneven wear, the sprockets are not aligned properly.
5. Inspect the drive and driven sprockets for the following defects:
 - a. Undercutting or sharp teeth (**Figure 42**).
 - b. Broken teeth.
6. Check the drive sprocket nut and the driven sprocket nuts for looseness. Refer to Chapter Thirteen.

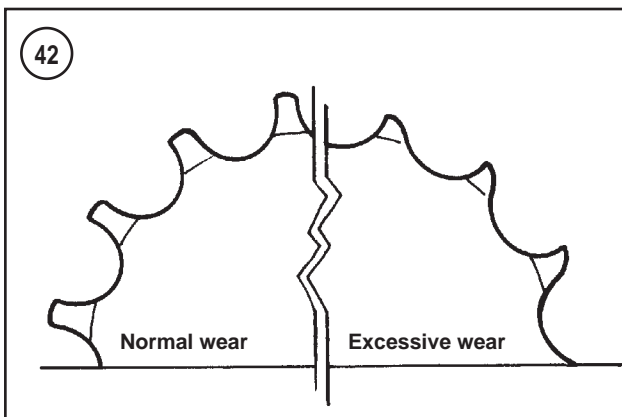
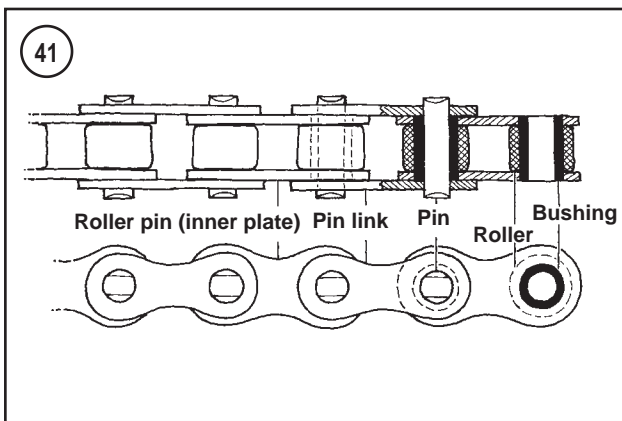
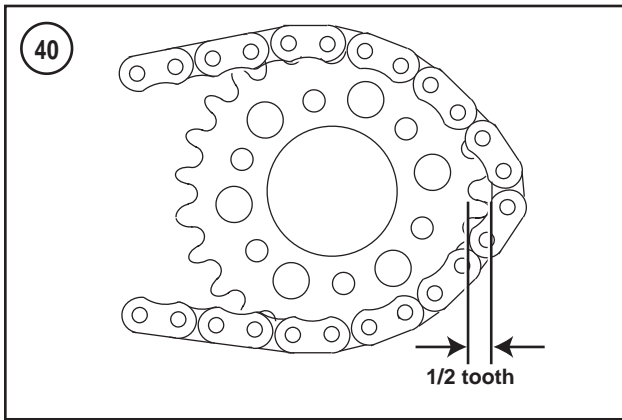

7. If excessive chain or sprocket wear is evident, replace the chain and both sprockets as a complete set (Chapter Thirteen).

Cleaning

1. Remove the drive chain as described in Chapter Thirteen.

CAUTION

Only kerosene should be used to clean O-ring drive chains. Do not use gasoline, solvent or paint thinner. Do not steam clean the chain.

2. Immerse the chain in a pan of cleaning solvent and allow it to soak for about a half hour. Move it around and flex it during this period so the dirt between the pins and rollers can work out.
3. Scrub the rollers and side plates with a stiff brush and rinse away loosened dirt. Rinse the chain a couple of times to make sure all debris is washed out. Hang up the chain and allow it to thoroughly dry.

NOTE

Do not allow a chain to remain dry and unlubricated for an extended period, otherwise, rust may occur.

4. Clean any dirt or grit off the sprockets.
5. Install the chain as described in Chapter Thirteen.
6. Lubricate the chain as described in this chapter.

Final Drive Belt

Deflection

Check drive belt deflection at the intervals in **Table 1**. If the drive belt is severely worn, or if it is wearing incorrectly, refer to Chapter Thirteen for inspection and replacement procedures.

NOTE

Check the drive belt deflection when the belt is cold.

1. Support the motorcycle on a stand or floor jack with the rear wheel off the ground. Refer to the *Motorcycle Stands* section in Chapter Thirteen.
2. Turn the rear wheel and check the drive belt for its tightest point. Mark this point. Turn the wheel so the tight spot is on the lower belt run, midway between the sprockets.
3. Lower the motorcycle to the ground.
4. Position the motorcycle so both wheels are on the ground without a rider or cargo on the motorcycle.
5. Observe the belt position through the window in the debris deflector (**Figure 43**). Mark the position of the belt.

NOTE

Use a belt tension gauge (A, **Figure 44**) (part No. HD-35381-A or equivalent) to apply pressure against the drive belt in Step 6. A suitable equivalent is the Yamaha belt tension tool (B, **Figure 44**).

NOTE

Be sure the belt tension gauge is positioned so it applies force squarely against the belt.

6. Apply a force of 10 lb. (4.5 kg) to the middle of the lower belt strand (**Figure 45**) and make another mark on the debris deflector to indicate the position of the deflected belt.
7. Note the number of graduations between the marks. Each graduation next to the window equals 1/8 in. (3.2 mm). Calculate the amount of belt deflection and refer to **Table 7** for the correct specification. Adjust the belt as described in this section.

Adjustment

1. Measure the belt deflection as described in in this section.
2. On the left side, remove the cotter pin (A, **Figure 36**) and loosen the rear axle nut (B).
3. Turn the adjuster locknut (C, **Figure 36**) on each side, in either direction, an equal number of turns to obtain the correct drive belt deflection.

CAUTION

The rear wheel must be properly aligned with the chassis so the drive belt runs true on the front and rear sprockets. A misaligned rear wheel will cause uneven, rapid drive belt wear.

4. Check that the rear axle is positioned correctly within the swing arm as follows:
 - a. Using a suitable metal rod, construct the tool shown in **Figure 38**.
 - b. Insert the end of the tool into the index hole in the swing arm (A, **Figure 39**).
 - c. Slide the rubber grommet along the tool until it aligns with the center of the axle (B, **Figure 39**).
 - d. Check alignment on the opposite side, comparing the rubber grommet position with the center of the axle. The alignment on both sides of the axle must be the same. If necessary, adjust the axle with the axle adjusters (**Figure 46**), while at the same time maintaining correct drive belt deflection.
5. Tighten the rear axle nut to 60-65 ft.-lb. (81-88 N•m) and install a new cotter pin.
6. Recheck the drive belt deflection. Tighten the adjuster locknuts securely.

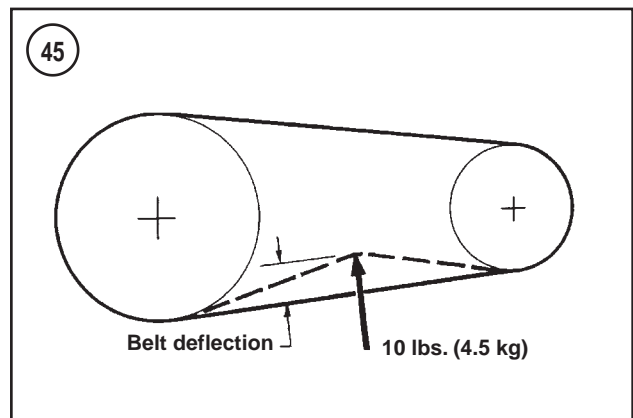
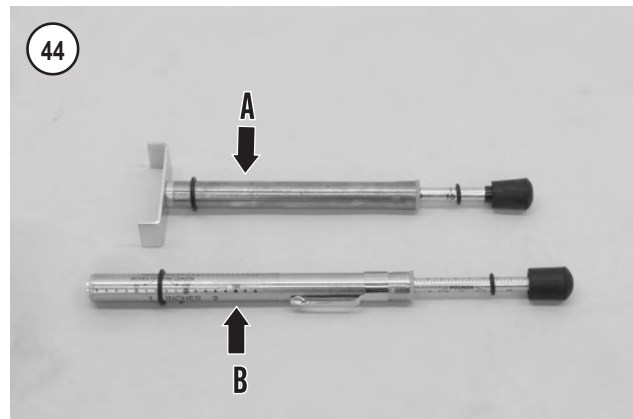



Brake Pad Inspection

NOTE

It may be necessary to dismount the caliper in the following steps if there is not sufficient access to the brake pads. Refer to Chapter Sixteen.

1. Inspect the brake pads for damage.
2. Measure the thickness of each brake pad lining on the front caliper(s) (**Figure 47**) and rear caliper (**Figure 48**). Replace the brake pad if its thickness is worn to the minimum thickness (**Figure 49**) as listed in **Table 7**. Replace the brake pads as described in Chapter Sixteen.

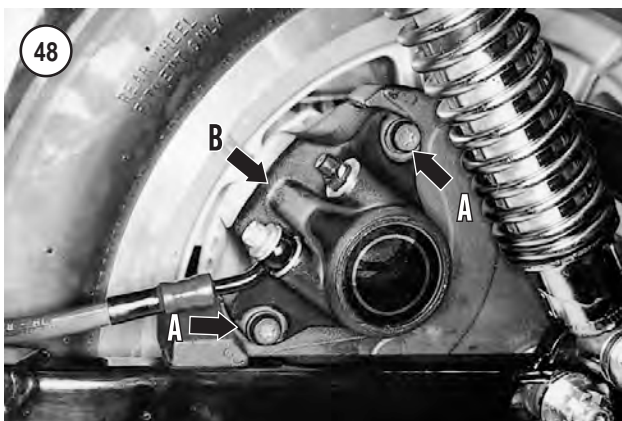

Brake Fluid Level Inspection

WARNING

If the reservoir is empty, air has probably entered the brake system. Bleed the breaks as described in Chapter Sixteen.

WARNING

Only use DOT 5 brake fluid. Do not use brake fluid labeled DOT 5.1. This is a glycol-based fluid that is not compatible with silicone-based DOT 5. DOT 5 fluid is purple while DOT 5.1 fluid is amber/clear. Do not intermix these different types of brake fluid as it can cause brake component damage and lead to brake system failure.

WARNING

Do not intermix DOT 3, DOT 4 or DOT 5.1 brake fluids as they are not silicone-based. Using non-silicone brake fluid in the models covered in this manual can cause brake failure.

NOTE

Low brake fluid levels usually indicated brake pad wear. As the pads wear and become thinner, the brake caliper pistons automatically extend farther out of their bores. As the caliper pistons move out, the brake fluid level drops in the system. However, if the brake fluid level is low and the brake pads are not worn excessively, check the system for leaks.

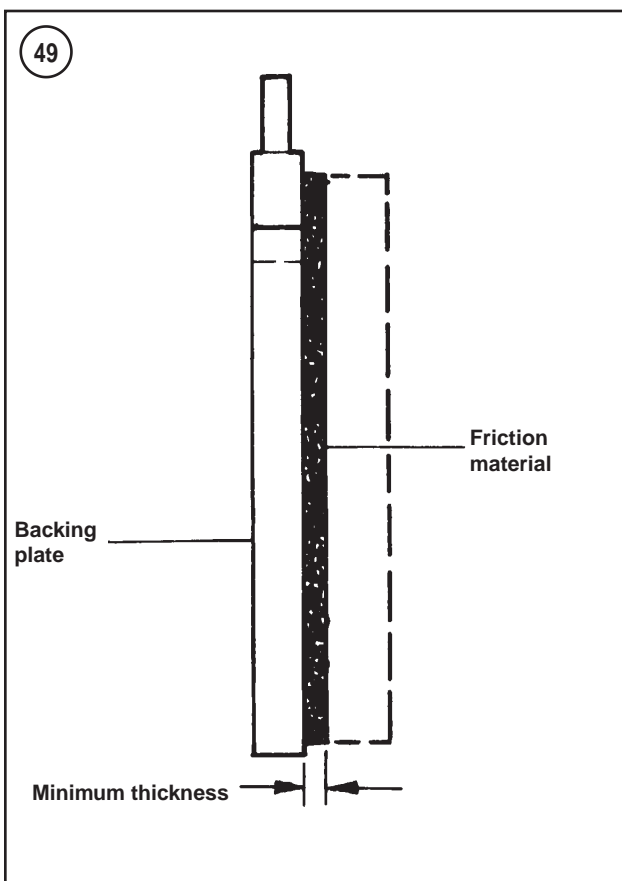

Front brake (1986-1995 models)

1. Move the handlebar so the front master cylinder is level.

NOTE

The sight glass on the side of the master cylinder (**Figure 50**) only provides a quick means to determine if the brake fluid level is low, not whether the reservoir is full.

2. Brake fluid should be visible in all of the sight glass (A, **Figure 50**).
3. Clean the top of the master cylinder.
4. Remove the screws securing the cover. Remove the cover and diaphragm.
5. The brake fluid level should be 1/8 inch (3.2 mm) below the top of the reservoir. If the brake fluid level is low, continue with Step 6. If the level is correct, continue with Step 7.
6. Add new DOT 5 brake fluid to raise the brake fluid level.
7. Reinstall the diaphragm and cover. Install the screws and tighten securely.

Front brake (1996-2003 models)

1. Move the handlebar so the front master cylinder is level.
2. Look at the sight glass on top of the master cylinder (A, **Figure 51**) to determine the brake fluid level. If the fluid level is correct, the sight glass will appear dark purple. If the level is low, the sight glass will be a light color or clear.
3. If the brake fluid level is low, add fluid as follows.
4. Clean the top of the master cylinder.
5. Remove the screws securing the cover (B, **Figure 51**). Remove the cover and diaphragm.
6. The brake fluid level should be 1/8 inch (3.2 mm) below the top of the reservoir. If the brake fluid level is low, continue with Step 7. If the level is correct, continue with Step 8.
7. Add new DOT 5 brake fluid to raise the brake fluid level.

NOTE

One side of the reservoir cover is thicker. Install the cover in Step 8 so the thick side is above the brake line fitting.

8. Reinstall the diaphragm and cover (B, **Figure 51**). Install the screws and tighten securely.

Rear brake

1. Park the motorcycle on level ground so the motorcycle is upright.

NOTE

*The sight glass (A, **Figure 52**) on the side of the master cylinder only provides a quick means to determine if the brake fluid level is low, not whether the reservoir is full.*

2. Brake fluid should be visible in all of the sight glass (A, **Figure 52**).
3. Clean the top of the master cylinder.
4. Remove the screws securing the cover (B, **Figure 52**). Remove the cover and diaphragm.
5. The brake fluid level should be 1/8 inch (3.2 mm) below the top of the reservoir. If the brake fluid level is low, continue with Step 6. If the level is correct, continued with Step 7.
6. Add fresh DOT 5 brake fluid to fill the reservoir.

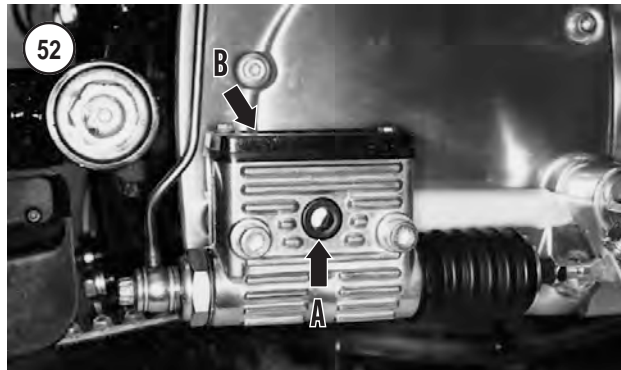
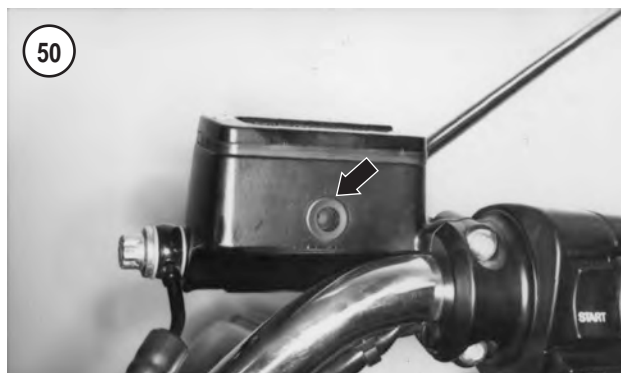

7. Reinstall the diaphragm and cover (B, **Figure 52**). Install the screws and tighten securely.

Brake Disc Inspection

Inspect the front and rear brake discs for scoring, cracks or other damage. Measure the brake disc thickness (**Figure 53**) and service the brake discs as described in Chapter Sixteen.

Brake Lines and Seals Inspection

Check the brake lines between each master cylinder and each brake caliper. If there are any leaks, tighten the connections and bleed the brakes as described in Chapter Sixteen.



Brake Fluid Change

WARNING

Do not use brake fluid labeled DOT 5.1. This is a glycol-based fluid that is not compatible with silicone-based DOT 5. DOT 5 brake fluid is purple while DOT 5.1 is an amber/clear color. Do not intermix these different types of brake fluid, as doing so will lead to brake component damage and possible brake failure.

To change brake fluid, follow the brake bleeding procedure in Chapter Sixteen. Continue adding new fluid to the master cylinder until the fluid leaving the caliper is clean and free of contaminants and air bubbles.

Front Brake Adjustment

The front brake does not require periodic adjustment.

Rear Brake Adjustment

1986-early 1987 models

1. Sit on the motorcycle in normal riding position. Adjust the position of the brake pedal to suit rider preference as described in the following steps.
2. Loosen the locknuts (A, **Figure 54**) on the pedal adjusting screw (B).
3. Turn the adjusting screw (B, **Figure 54**) until the desired pedal position is obtained.

4. Tighten the locknuts (A, **Figure 54**) and recheck the pedal position.
5. Push the brake pedal by hand until light resistance is felt, which indicates the pushrod (17, **Figure 55**) is contacting the piston (12).
6. Measure the gap between the adjusting screw (B, **Figure 54**) and the brake pedal. The gap should be 1/16 in. (1.6 mm). If not, proceed as follows:
 - a. Loosen the locknut (18, **Figure 55**).
 - b. Turn the pushrod (17, **Figure 55**) as needed to obtain the desired gap.
 - c. Tighten the locknut (18, **Figure 55**).

Later 1987-2003 models, except 1999-2003 883C and 1200C models

1. Park the motorcycle on level ground so the motorcycle is upright.
2. Note the brake pedal position with relation to the floor. The brake pedal (**Figure 56**) should be parallel with the floor.
3. Remove the cotter pin securing the clevis pin (A, **Figure 57**) to the rear brake pedal. Remove the clevis pin.
4. Disconnect the brake rod end from the brake pedal.
5. Loosen the locknut (B, **Figure 57**) and turn the brake rod end (C) as needed to reposition the brake pedal.
6. When the brake pedal is properly positioned, reinstall the clevis pin and secure it with a new cotter pin.

1999-2003 883C and 1200C models

Refer to the *Forward Foot Controls* section in Chapter Seventeen.

Clutch Adjustment

1986-1993 models

NOTE

The clutch cable adjuster on 1986-1987 models is located at the lower end of the cable (A, **Figure 58**). On 1988-1993 models, the cable adjuster is located at mid-length in the cable adjacent to the front frame down-tube (**Figure 59**).

Refer to **Figure 60** when performing this procedure.

- 1A. On 1986-1987 models, loosen the clutch cable jam nut (B, **Figure 58**) and turn the adjuster (A) to provide maximum cable slack.
- 1B. On 1988-1993 models, slide the rubber boot off the clutch in-line cable adjuster. Loosen the adjuster jam nut (A, **Figure 59**) and turn the adjuster (B) to provide maximum cable slack.
2. Make sure the clutch cable ferrule seats squarely in the lever housing receptacle (**Figure 61**) on the handlebar.
3. Remove the clutch inspection cover (**Figure 62**).

148

**REAR MASTER CYLINDER
(1986-EARLY 1987 MODELS)**

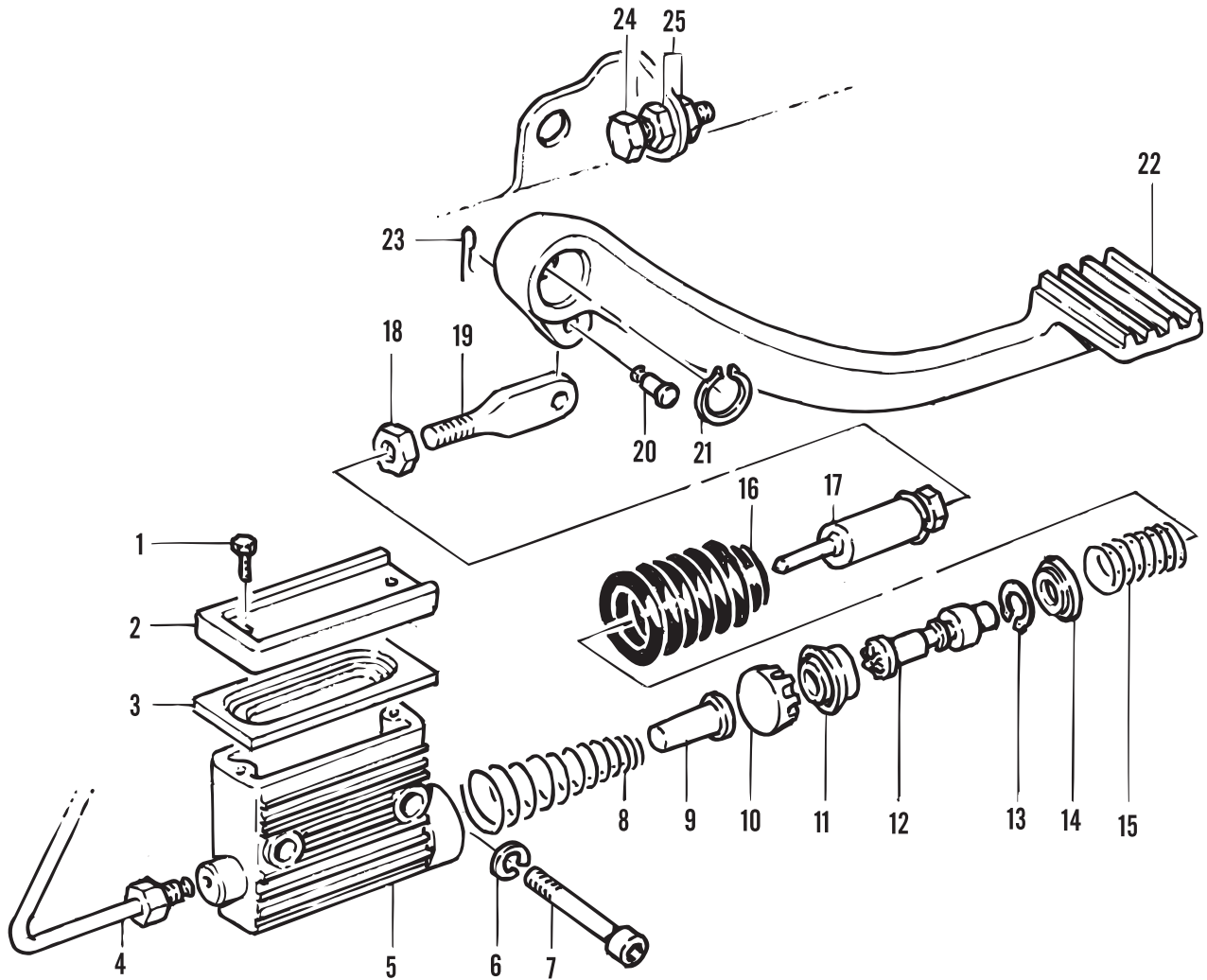

- | | |
|----------------|---------------------|
| 1. Screw | 14. Cupped washer |
| 2. Cover | 15. Spring |
| 3. Diaphragm | 16. Rubber boot |
| 4. Brake line | 17. Pushrod |
| 5. Housing | 18. Nut |
| 6. Lockwasher | 19. Rod end |
| 7. Bolt | 20. Pin |
| 8. Spring | 21. Snap ring |
| 9. Spring seat | 22. Brake pedal |
| 10. Piston cup | 23. Cotter pin |
| 11. Seal | 24. Adjusting screw |
| 12. Piston | 25. Locknuts |
| 13. Snap ring | |

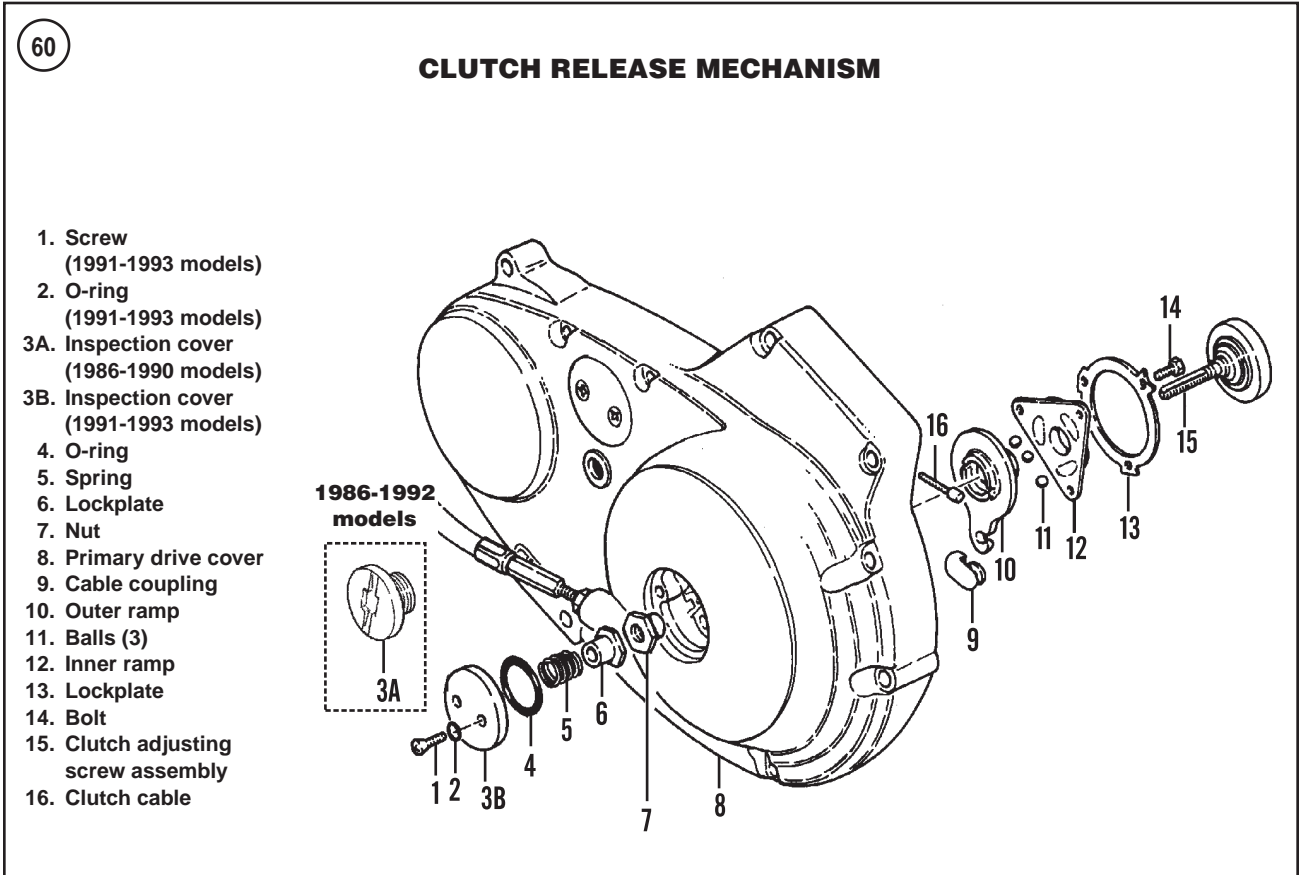
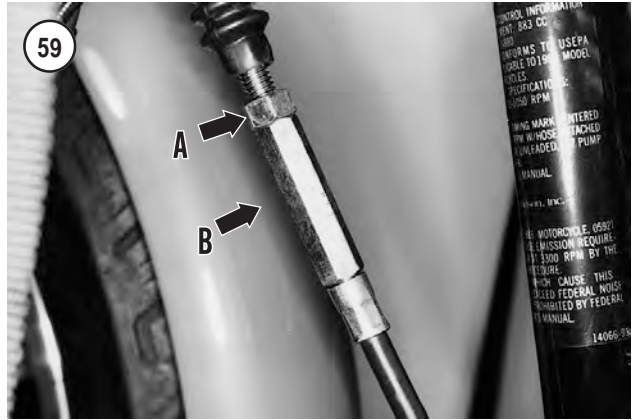
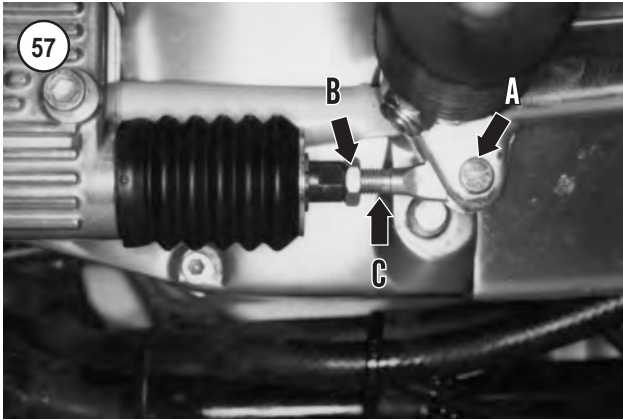
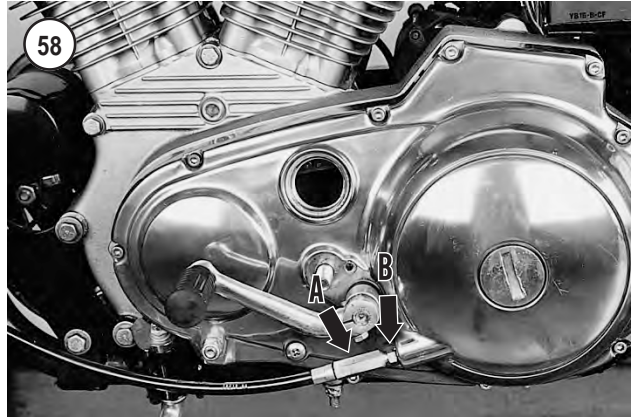
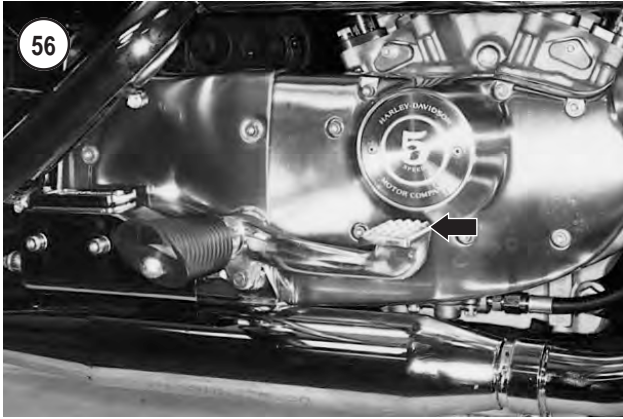

4. At the clutch mechanism, remove the spring and lockplate assembly (**Figure 63**).
5. Turn the adjusting screw (**Figure 64**) counterclockwise until it is lightly seated.
6. Turn the adjusting screw 1/4 turn clockwise.
7. Reinstall the spring and lockplate assembly (**Figure 65**) so it fits inside the outer ramp recess. If necessary, turn the adjusting screw clockwise until the flats on the lockplate fit into the flats in the outer ramp.
8. Install the clutch inspection cover and O-ring.
9. Check the free play as follows:
 - a. At the inline cable adjuster, turn the adjuster away from the jam nut until slack is eliminated at the clutch hand lever.
 - b. Pull the clutch cable end away from the clutch lever, then turn the clutch cable adjuster to obtain free play (**Figure 66**) of 1/16-1/8 in. (1.6 mm).
 - c. When the adjustment is correct, tighten the clutch inline cable jam nut.

1994-2003 models

1. Remove the clutch inspection cover (**Figure 67**) and quad ring.
2. Slide the rubber boot off the clutch in-line cable adjuster.
3. Loosen the adjuster jam nut (A, **Figure 59**) and turn the adjuster (B) to provide maximum cable slack.
4. Make sure the clutch cable ferrule seats squarely in the lever housing receptacle (**Figure 61**) on the handlebar.
5. At the clutch mechanism, remove the spring and lockplate assembly (A, **Figure 68**).
6. Turn the adjusting screw (**Figure 69**) counterclockwise until it is lightly seated.
7. Turn the adjusting screw 1/4 turn clockwise.
8. Reinstall the spring and lockplate assembly (A, **Figure 68**) so it fits inside the outer ramp recess (B). If necessary, turn the adjusting clockwise until the flats on the lockplate fit into the flats in the outer ramp.
9. Be sure the quad ring is located in the primary drive cover groove.
10. Install the inspection cover so the notch in the cover fits over the cable boss on the primary drive cover. Tighten the retaining screws to 84-108 in.-lb. (9.5-12.0 N•m).
11. Check the free play as follows:
 - a. At the inline cable adjuster, turn the adjuster away from the jam nut until slack is eliminated at the clutch hand lever.
 - b. Pull the clutch cable end away from the clutch lever, then turn the clutch cable adjuster to obtain the freeplay of 1/16-1/8 in. (1.6-3.2 mm).
 - c. When the adjustment is correct, tighten the clutch inline cable jam nut and slide the rubber boot over the cable adjuster.

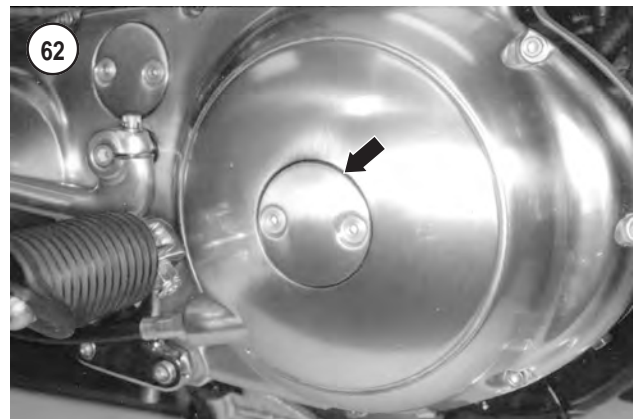

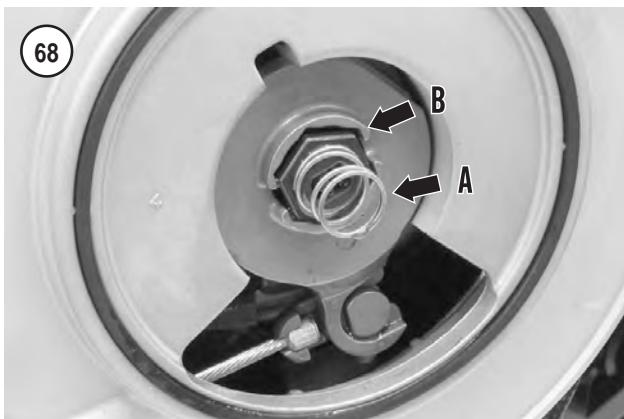
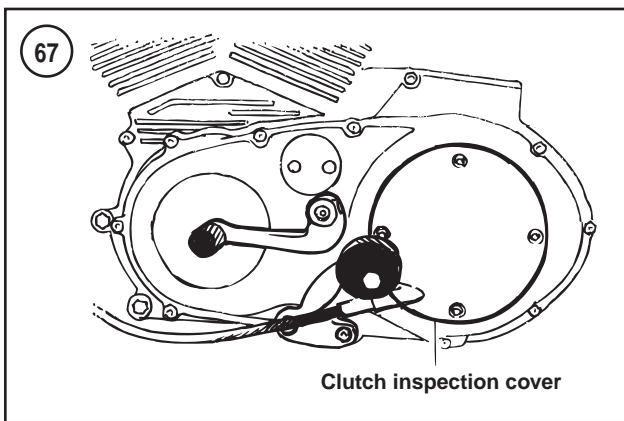
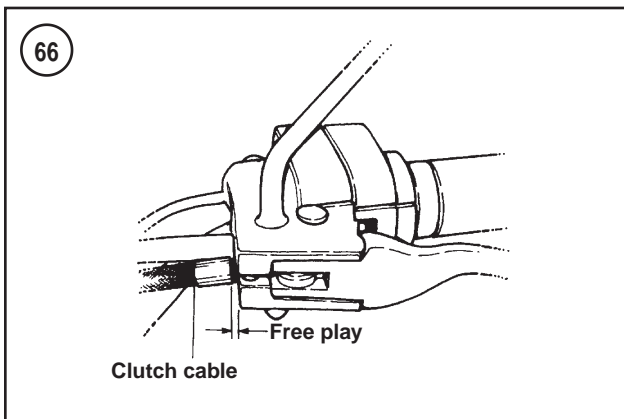

**Shift Lever Adjustment
(1999-2003 883C and 1200C Models)**

Refer to the *Forward Foot Controls* section in Chapter Seventeen.

Throttle Cables

Inspection

Inspect the throttle cables from the grip to the carburetor. Make sure they are not kinked or chafed. Replace them if necessary as described in Chapter Ten or Chapter Eleven.

Make sure the throttle grip rotates smoothly from fully closed to fully open. Check with the handlebar at the center, full left and full right positions.

Adjustment

WARNING

Do not ride the motorcycle until the throttle cables are properly adjusted. Also, the cables must not catch or pull when the handlebar is turned from side to side. Improper cable routing and adjustment can cause the throttle to stick open. This could cause loss of control and a possible crash. Recheck this adjustment before riding the motorcycle.

There are two different throttle cables. At the throttle grip, the front cable is the throttle control cable and the rear cable is the idle control cable. Label the cables before removal.

At the carburetor on 1986-1987 models, the outboard cable is the idle control cable and the inboard cable is the throttle control cable. Label the cables before removal.

At the carburetor on 1988-2003 models, the outboard cable is the throttle control cable and the inboard cable is the idle control cable. Label the cables before removal.

1. Remove the air filter and backing plate as described in Chapter Ten or Chapter Eleven.
2. Push back the rubber boots from the adjusters.

3. Loosen the throttle friction screw on the bottom of the throttle control housing.
4. At the handlebar, loosen both control cable adjuster jam nuts (A, **Figure 70**), then turn the cable adjusters (B and C) to increase cable slack.
5. Turn the handlebars so the front wheel points straight ahead. Turn the throttle grip to open the throttle completely and hold it in this position.
- 6A. On 1986-1987 models, at the handlebar, turn the throttle control (B, **Figure 70**) cable adjuster until the throttle cam stop just touches the stop boss (**Figure 71**) on the carburetor body. Tighten the throttle cable adjuster jam nut and release the throttle grip.

NOTE

*The carburetor is shown removed in **Figure 72** to better illustrate the steps.*

- 6B. On 1988-2003 models, at the handlebar, turn the throttle control (B, **Figure 70**) cable adjuster until the throttle cam (A, **Figure 72**) stop just touches the stop boss (B) on the carburetor body. Tighten the throttle cable adjuster jam nut and release the throttle grip.
7. Turn the front wheel all the way to the fall right lock position and hold it there.
8. At the handlebar, turn the idle cable (C, **Figure 70**) adjuster until the lower end of the idle control cable (B, **Figure 72**) just contacts the spring in the carburetor cable guide. Tighten the idle cable jam nut.
9. Install the backing plate and the air filter as described in Chapter Ten or Chapter Eleven.
10. Shift the transmission into neutral and start the engine.
11. Increase engine speed several times. Release the throttle and make sure the engine speed returns to idle. If the engine speed does not return to idle, at the handlebar, loosen the idle control cable adjuster jam nut and turn the cable adjuster as required. Tighten the idle control cable adjuster jam nut.
12. Allow the engine to idle in neutral, then turn the handlebar from side to side. Do not operate the throttle. If the engine speed increases when the handlebar assembly is turned, the throttle cables are routed incorrectly or damaged. Turn off the engine. Recheck cable routing and adjustment.
13. Push the rubber boots back onto the adjusters.

Choke Cable Adjustment (1986-1987 Models)

The choke cable on 1986-1987 models operates the choke plate in the carburetor (**Figure 73**). Cable adjustment may be necessary to obtain proper operation.

1. Remove the air cleaner as described in Chapter Ten.
2. Operate the choke control knob (**Figure 74**) and verify that the choke plate operates correctly.

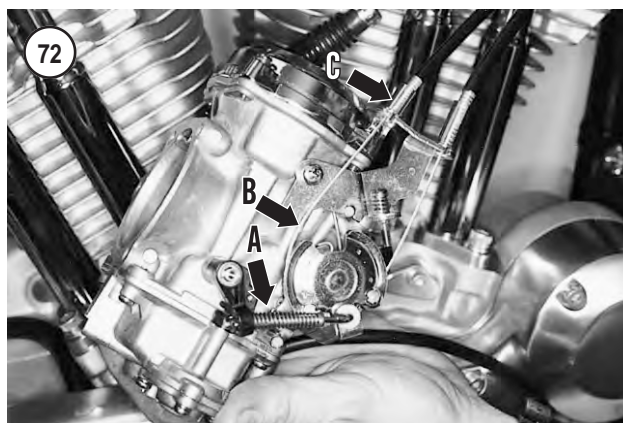
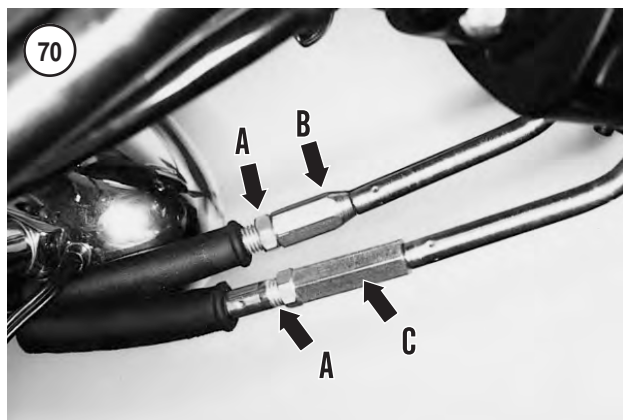

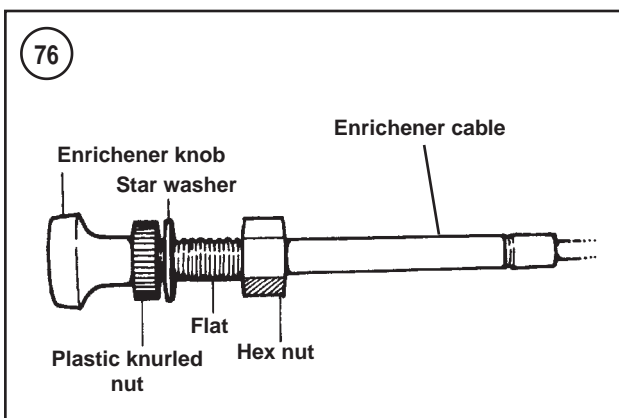
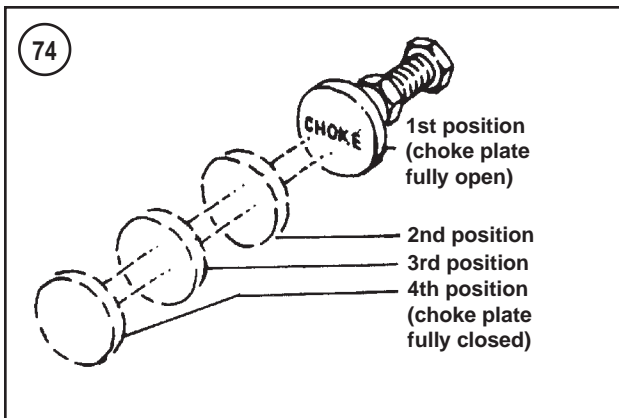

3. If necessary, adjust the choke by loosening the nuts at the choke knob and adjusting the length of the cable. Tighten the nuts and recheck operation.

Starting Enrichment Valve (Choke) Cable Adjustment (1988-2003 Models)

CAUTION

The starting enrichment (choke) cable must have sufficient cable resistance to work properly. Do not lubricate the enrichment cable or its conduit.

The starting enrichment (choke) knob (**Figure 75**) should move from fully open to fully closed position without any sign of binding. The knob should also stay in its fully closed or fully open position without creeping. If the knob does not stay in position, adjust tension on the cable by turning the plastic knurled nut behind the knob. Refer to **Figure 76**.

1. Loosen the hex nut behind the mounting bracket. Disengage the cable from the mounting bracket.
2. Hold the cable flats with a wrench and turn the knurled plastic nut counterclockwise to reduce cable resistance. Continue until the knob will move in freely.
3. Turn the knurled plastic nut clockwise to increase cable resistance. Continue adjustment until the knob will remain stationary when it is pulled all the way out, but will move in relatively easily. The knob must move without any roughness or binding.
4. Reinstall the cable into the mounting bracket slot with the star washer located between the bracket and hex nut. Tighten the hex nut securely.
5. Recheck the knob movement and readjust if necessary.

Fuel Line Inspection

WARNING

A damaged or deteriorated fuel line can cause a fire or explosion if fuel spills onto a hot engine or exhaust pipe.

Inspect the fuel line from the fuel tank to the carburetor. Replace leaking or damaged fuel lines. Make sure the hose clamps are in place and holding securely. Check the hose fittings for looseness.

Exhaust System

Check all fittings for exhaust leaks. Do not forget the crossover pipe or interconnecting tube connections. Tighten all fasteners. Replace gaskets as necessary. Refer to Chapter Ten or Chapter Eleven for removal and installation procedures.

Steering Play

Check the steering play adjustment (Chapter Fourteen) at the intervals in **Table 1**.

Rear Swing Arm Pivot Bolts

Check the rear swing arm pivot bolt tightness (Chapter Fourteen) at the intervals specified in **Table 1**.

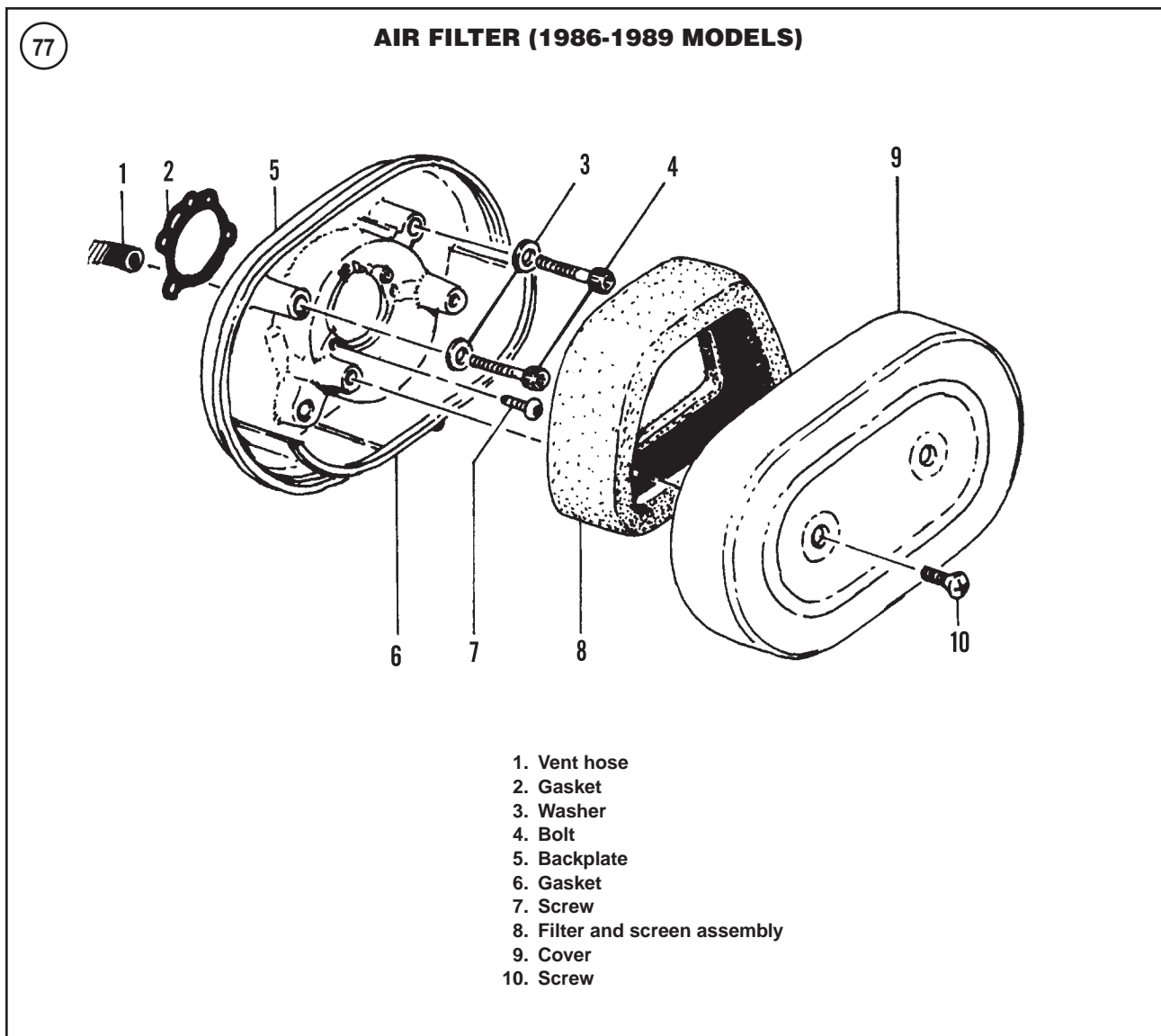

Rear Shock Absorbers

Check the rear shock absorbers for oil leaks or damaged bushings. Check the shock absorber mounting bolts and nuts for tightness. Refer to *Shock Absorbers* in Chapter Fifteen for procedures.

Engine Mounting Hardware

Check the engine and frame mounts for loose or damaged parts. Refer to Chapter Five for procedures.

Fasteners

CAUTION

*Special procedures must be used to tighten the cylinder head mounting bolts. To accurately check these bolts for tightness, refer to **Cylinder Head** in Chapter Four. Tightening*

these bolts incorrectly can cause oil leaks or cylinder head warp.

Constant vibration can loosen many fasteners on a motorcycle. Check the tightness of all fasteners, especially:

1. Engine mounting hardware.
2. Engine and primary drive covers.
3. Handlebar and front fork.
4. Gearshift lever.
5. Sprocket bolts and nuts.
6. Brake lever and pedal.
7. Exhaust system.
8. Lighting equipment.

Electrical Equipment and Switches

Check all of the electrical equipment and switches for proper operation. Refer to Chapter Twelve.

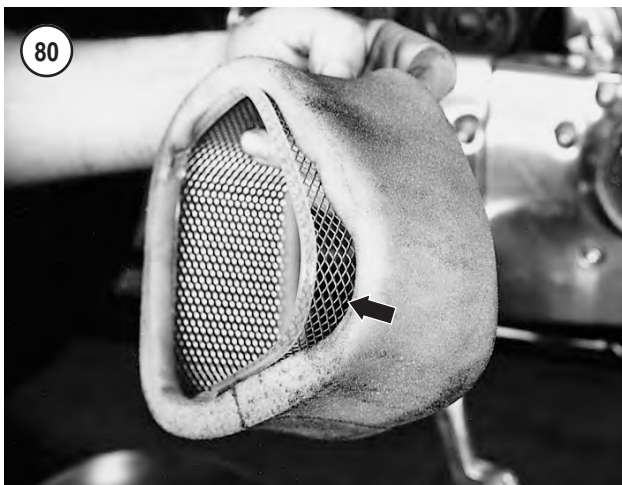
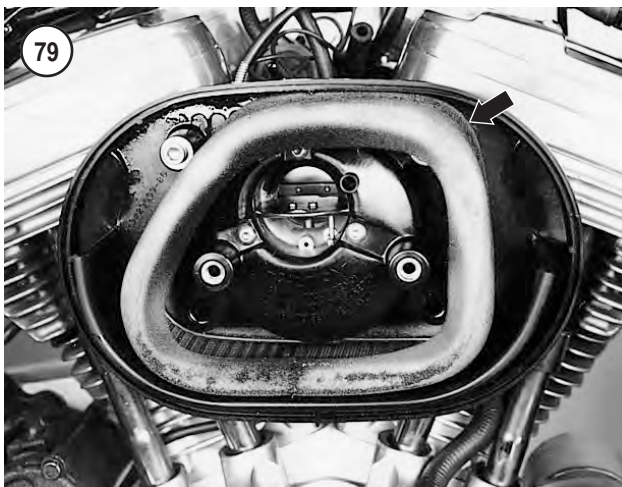

TUNE-UP

The following section describes tune-up procedures. Perform the tasks at the intervals listed in **Table 1**. Perform a complete tune-up in the following order:

1. Clean or replace the air filter.
2. Check engine compression.

3. Check or replace the spark plugs.
4. Check the ignition timing.
5. Adjust the idle speed.

AIR FILTER

Removal/Cleaning/Installation

Remove and inspect the air filter at the interval in **Table 1**. If necessary, clean the element. Replace the element if it is damaged.

Never run the motorcycle without the element installed.

1986-1989 models

Refer to **Figure 77**.

1. Remove the air filter cover screws and remove the cover (**Figure 78**).
2. Remove the air filter element (**Figure 79**).
3. Remove the wire mesh frame from inside the filter (**Figure 80**).
4. Wash the filter in soap and water and allow to dry completely.
5. Inspect the filter and make sure it is in good condition with no sign of damage. Replace if necessary.
6. After the filter is dry, saturate the filter with air filter oil. Work the oil into the filter, then squeeze out excess oil. The oil should have a uniform color, which indicates thorough oil dispersion.
7. Reinstall the wire mesh frame (**Figure 80**).
8. Clean the inside of the cover and backplate with a rag and cleaning solvent. Remove any debris that may have passed through a damaged filter.
9. Install the filter by reversing the removal steps.

1990-2003 models

Refer to **Figure 81**.

1. Remove the air filter cover screws and remove the cover (**Figure 82**).
2. Remove the air filter element (**Figure 83**).

NOTE

The air filter element is a paper/wire type. If an aftermarket element is installed, refer to the manufacturer's cleaning instructions.

3. Replace the air filter if damaged.

WARNING

Do not clean the air filter in solvent. Never clean the air filter element in gasoline or low flash point solvent. The residual solvent or vapors may cause a fire or explosion after the filter is reinstalled.

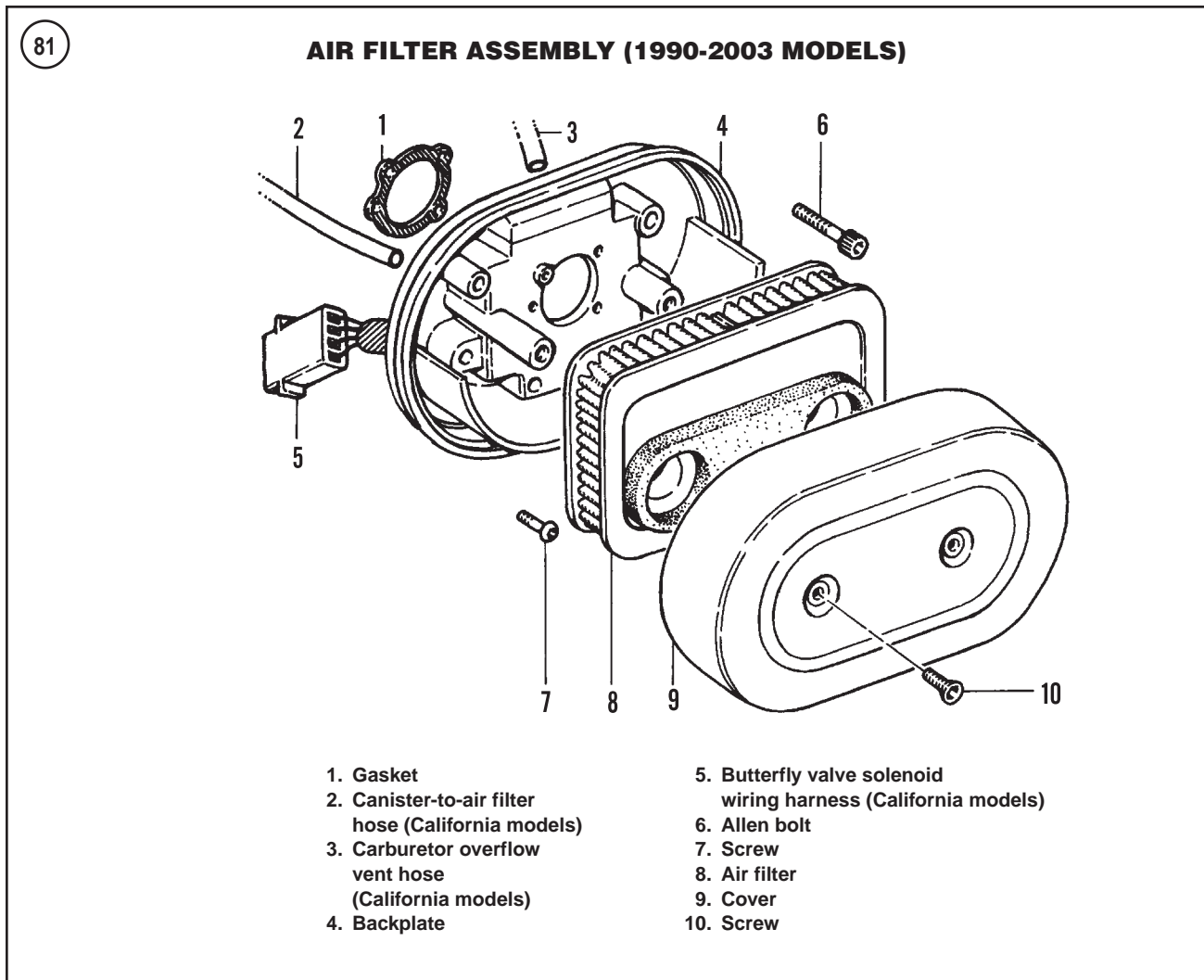
**CAUTION**

Do not tap or strike the air filter element on a hard surface to dislodge dirt. Doing so damages the element.

- Place the air filter in a pan filled with lukewarm water and mild detergent. Move the air filter element back and forth to help dislodge trapped dirt. Thoroughly rinse it in clean water to remove all detergent residue.
- Hold the air filter up to a strong light. Check the filter pores for dirt and oil. Repeat Step 4 until there is no dirt and oil in the filter pores. If the air filter cannot be cleaned, or if the filter is saturated with oil or other chemicals, replace it.

CAUTION

Do not use high air pressure to dry the filter, as this will damage it. Maximum air pressure should be 32 psi (220kPa).

CAUTION

Do not blow compressed air through the outer surface of the air filter element. Doing so can force dirt trapped on the outer filter surface deeper into the air filter element, re-

stricting airflow and damaging the air filter element.

- Apply compressed air through the inside surface of the air filter element to remove loosened dirt and dust trapped in the filter.
- Inspect the air filter element. Replace it if it is torn or damaged.
- Wipe the inside of the cover and backplate with a clean damp shop rag.

CAUTION

Air will not pass through a wet or damp filter. Make sure the filter is dry before installing it.

- Allow the filter to dry completely.
- Reinstall the filter by reversing the removal steps.

COMPRESSION TEST

A compression test is one of the quickest ways to check the internal condition of the engine (piston rings, pistons,



head gasket, valves and cylinders). It is a good idea to check compression at each tune-up, record it in the maintenance log at the back of the manual, and compare it with subsequent readings.

Use a screw-in type compression gauge with any necessary adapter (refer to Chapter One). Before using the gauge, make sure the rubber gasket on the end of the gauge hose adapter is in good condition.

1. Before starting the compression test, make sure the following items are correct:

- a. The battery is fully charged (Chapter Twelve).

- b. The cylinder head bolts are properly tightened (Chapter Four).
2. Run the engine until it reaches normal operating temperature, then turn it off.
3. Remove all the spark plugs as described in this chapter.
4. Connect a grounding tool (Chapter One) to the spark plug wires to prevent damage to the ignition system components.
5. Lubricate the threads of the compression gauge adapter with a small amount of antiseize compound and thread the gauge into one of the spark plug holes.

NOTE

On 1986-1987 models make sure the choke is off.

6. Move the engine stop switch to the run position, then turn the ignition switch to the ignition position. Open the throttle completely and crank the engine until there is no further rise in pressure. Maximum pressure is usually reached within 4-7 seconds of engine cranking. Record the reading and the cylinder location.
7. Repeat Step 5 and Step 6 for the other cylinder.
8. When interpreting the results, actual readings are not as important as the difference between the readings. Compression is considered normal if the indicated pressure is 120 psi (828 kPa), and the compression reading of a cylinder does not differ from the remaining cylinder by 10 psi (69 kPa). Low compression indicates worn or broken rings, leaky or sticky valves, blown head gasket or a combination of all three.
 - a. If the compression reading does not differ between cylinders by more than 10 percent, the rings and valves are in good condition.
 - b. If a reading difference of 10 percent or more is obtained on one of the cylinders, it indicates valve or piston ring trouble. To determine which, pour about a teaspoon of engine oil into the spark plug hole of the cylinder with low compression. Turn the engine over once to distribute the oil, then take another compression test and record the reading. If the compression increases significantly, the valves are good but the rings are defective in that cylinder. If compression does not increase, the valves require servicing.
9. Install the spark plugs as described in this chapter.

SPARK PLUGS

Removal

As each spark plug is removed, label it with its cylinder location and refer to *Reading* in this section.

1. Grasp the spark plug lead (**Figure 84**) by the cap portion, not by the wire. Pull the lead off the plug.

CAUTION

Whenever the spark plugs are removed, dirt around the opening can fall into the spark plug hole. This can cause serious engine damage.

2. Clean the area around the spark plug using compressed air. Make sure all loose debris or small parts that could fall into the spark plug holes in the cylinder head are removed.
3. Install the spark plug socket onto the spark plug. Make sure it is correctly seated before removing the spark plug. Identify the spark plug according to the cylinder from which it was removed.
4. Repeat Step 3 for the remaining spark plug(s).
5. Inspect the spark plugs carefully. Refer to *Reading* in this section. Look for plugs with broken center porcelain, excessively eroded electrodes and excessive carbon or oil fouling. Replace defective plugs.
6. Inspect the spark plug cap and wire. Replace the spark plug wire if the receptacle or wire is damaged.

Gap

Adjust the gap of new plugs to ensure a reliable, consistent spark. To do this, use a spark plug gapping tool with a wire gauge.

1. Insert a wire gauge between the center and the side electrode of the plug (**Figure 85**). The correct gap is listed in **Table 7**. If the gap is correct, a slight drag should be felt as the gauge is pulled through. If there is no drag, or if the gauge will not pass through, bend the side electrode with the gapping tool (**Figure 86**) to set the proper gap listed in **Table 7**.
2. Repeat for the remaining spark plug(s).
3. Install the terminal nut (A, **Figure 87**).

Installation

1. Apply a light coat of antiseize compound onto the threads (B, **Figure 87**) of the spark plug before installing it. Remove any compound that contacts the plug electrodes. Do not use engine oil on the plug threads.

CAUTION

The cylinder head is aluminum. If the spark plug is cross-threaded into the cylinder head, the internal threads will be damaged.

2. Screw the spark plug in by hand until it seats. Very little effort is required. If force is necessary, the plug may be cross-threaded. Unscrew it and try again.

CAUTION

Do not overtighten the spark plug. This will crush the gasket and destroy its sealing ability. Overtightening may also damage the spark plug threads in the cylinder head.

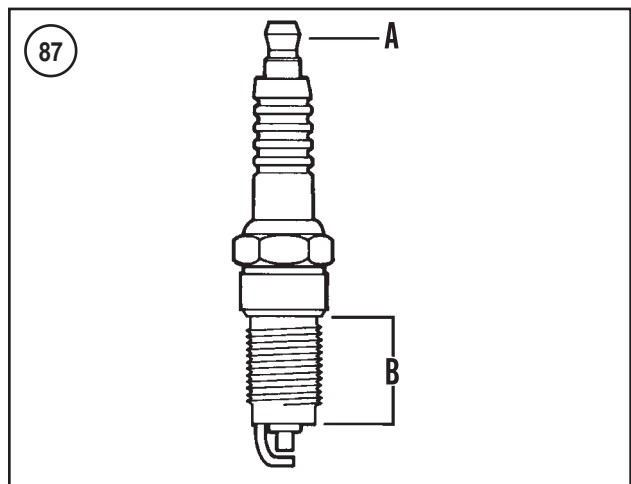
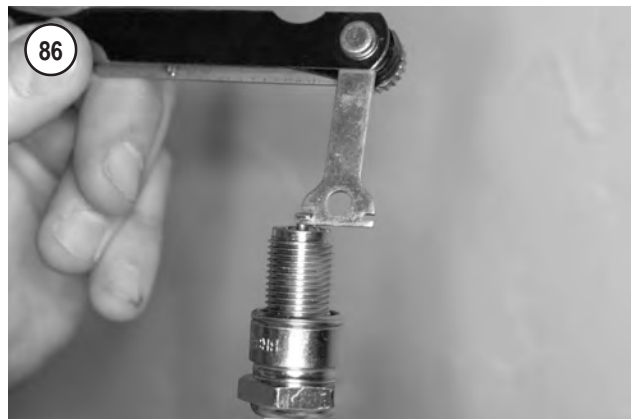
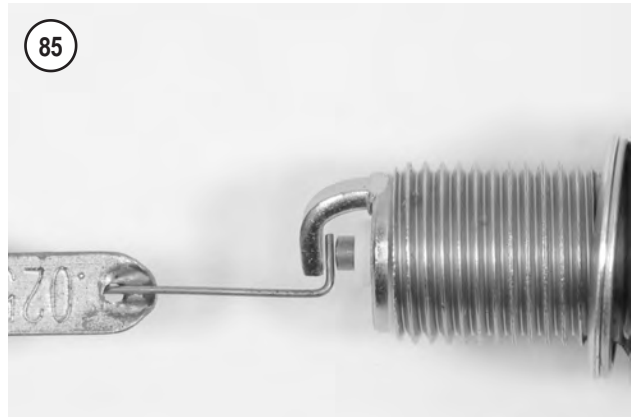

3. Tighten the spark plug to 11 ft.-lb. (15-24 N•m). If a torque wrench is not available, tighten it 1/4 turn after the gasket contacts the head.
4. Connect all spark plug leads and push them down until they are completely seated. Repeat for the remaining spark plug(s).

Reading

Inspecting or reading the spark plugs can provide a significant amount of information regarding engine perfor-

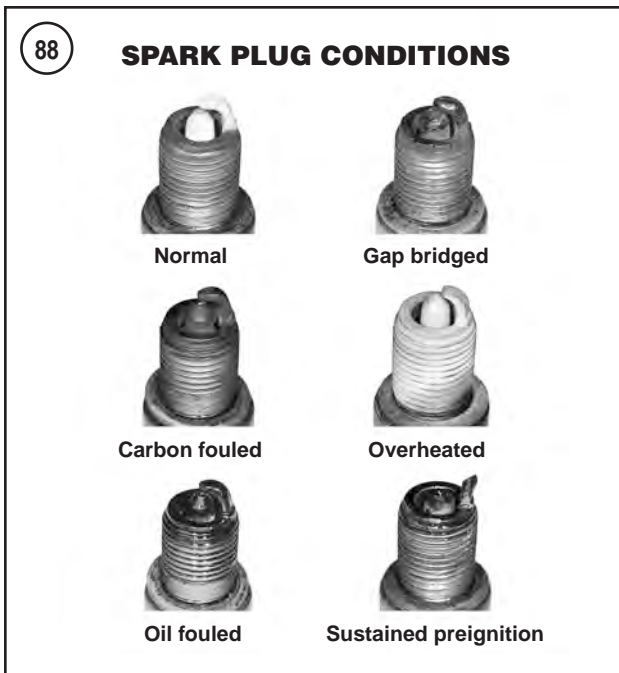

mance. Reading plugs that have been in use will give an indication of spark plug operation, air/fuel mixture composition and engine conditions (such as oil consumption or piston wear). Before checking new spark plugs, operate the motorcycle under a medium load for approximately 6 miles (10 km). Avoid prolonged idling before shutting off the engine. Remove the spark plugs as described in this section. Examine each plug and compare it to those in **Figure 88**.

Spark plugs are available in various heat ranges, hotter or colder than the plugs originally installed by the manufacturer. Do not change the spark plug heat range to compensate for adverse engine or air/fuel mixture conditions.

When replacing plugs, make sure the reach (B, **Figure 87**) is correct. A longer than standard plug could interfere with the piston, causing engine damage. Refer to **Table 7** for recommended spark plugs.

Normal condition

If the plug has a light tan- or gray-colored deposit and no abnormal gap wear or erosion, good engine, fuel system and ignition conditions are indicated. The plug in use is of the proper heat range and may be serviced and returned to use.

Carbon fouled

Soft, dry, sooty deposits covering the entire firing end of the plug are evidence of incomplete combustion. Even though the firing end of the plug is dry, the plug's insulation decreases when in this condition. The carbon forms an electrical path that bypasses the spark plug electrodes, resulting

in a misfire condition. One or more of the following can cause carbon fouling:

1. Rich fuel mixture.
2. Cold spark plug heat range.
3. Clogged air filter.
4. Improperly operating ignition component.
5. Ignition component failure.
6. Low engine compression.
7. Prolonged idling.

Oil fouled

The tip of an oil fouled plug has a black insulator tip, a damp oily film over the firing end and a carbon layer over the entire nose. The electrodes are not worn. Oil fouled spark plugs may be cleaned in an emergency, but it is better to replace them. It is important to correct the cause of the fouling before the engine is returned to service. Common causes for this condition are:

1. Incorrect air/fuel mixture.
2. Low idle speed or prolonged idling.
3. Ignition component failure.
4. Cold spark plug heat range.
5. Engine still being broken in.
6. Valve guides worn.
7. Piston rings worn or broken.

Gap bridging

Plugs with this condition exhibit gaps shorted out by combustion deposits between the electrodes. If this condition is encountered, check for excessive carbon or oil in the combustion chamber. Be sure to locate and correct the cause of this condition.

Overheating

Badly worn electrodes and premature gap wear are signs of overheating, along with a gray or white blistered porcelain insulator surface. The most common cause for this condition is using a spark plug of the wrong heat range (too hot). If the spark plug is in the correct heat range and is overheating, consider the following causes:

1. Lean air/fuel mixture.
2. Improperly operating ignition component.
3. Cooling system malfunction.
4. Engine lubrication system malfunction.
5. Engine air leak.
6. Improper spark plug installation.
7. No spark plug gasket.

Worn out

Corrosive gases formed by combustion and high voltage sparks have eroded the electrodes. A spark plug in this con-

dition requires more voltage to fire under hard acceleration. Replace with a new spark plug.

Preignition

If the electrodes are melted, preignition is almost certainly the cause. Check for intake air leaks at the manifolds and carburetors. Also check for advanced ignition timing. It is also possible that a plug of the wrong heat range (too hot) is being used. Find the cause of the preignition before returning the engine into service.

IGNITION TIMING ADJUSTMENT

Ignition timing specifications are listed in **Table 8**.

1986-1994 Models

1. Remove the plug from the timing hole on the right side of the engine (**Figure 89**). A clear plastic viewing plug is available to minimize oil spray. Make sure the plug does not contact the flywheel after installation.
2. On models not equipped with a tachometer, attach a shop tachometer to the engine following the manufacturer's instructions.
3. Connect an inductive clamp-on timing light to the front cylinder spark plug wire following the manufacturer's instructions.
4. Start the engine and allow it to warm to normal operating temperature. Then set idle speed to 1650-1950 rpm.
5. Aim the timing light at the timing inspection hole. At 1650-1950 rpm, the front cylinder advance mark should appear in the center of the inspection window as shown in **Figure 90**. If the mark does not align, adjust the ignition timing starting with Step 6. If the ignition timing is correct, proceed to Step 9.
6. Remove the sensor plate outer cover, inner cover and gasket as described in *Ignition System* in Chapter Twelve.
7. Loosen the timing plate screws (**Figure 91**) just enough to allow the plate to rotate. Start the engine and turn the plate as required so that the advanced mark is aligned as described in Step 5. To adjust the plate, use a screwdriver in the plate's slot. Make sure idle speed remains between 1650-1950 rpm checking timing. Tighten the screws (**Figure 91**) and recheck ignition timing.
8. Install the sensor plate gasket, inner cover and outer cover.
9. As part of the tune-up, check the vacuum operated electric switch (VOES) as follows:

CAUTION

The Vacuum Operated Electric Switch (VOES) must be tested at each tune-up and replaced if malfunctioning. A damaged VOES switch will allow too high a spark advance

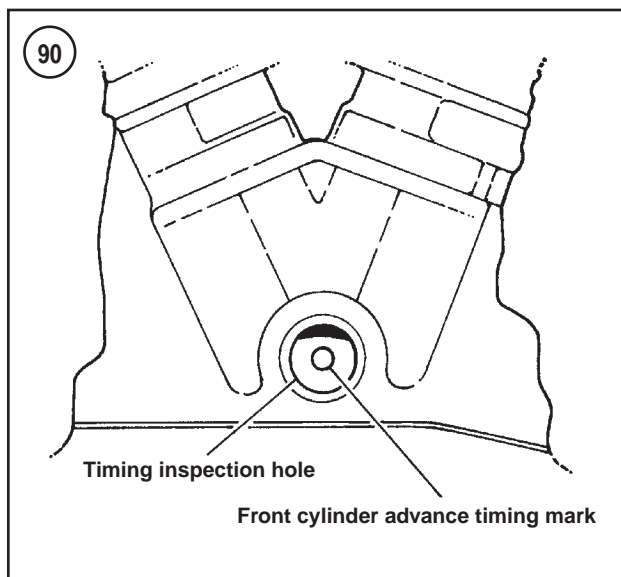

which can cause severe engine knock and damage.

- a. Start the engine and allow it to idle.
- b. On 1986-1990 models, disconnect the VOES vacuum hose from the carburetor (**Figure 92**) with the

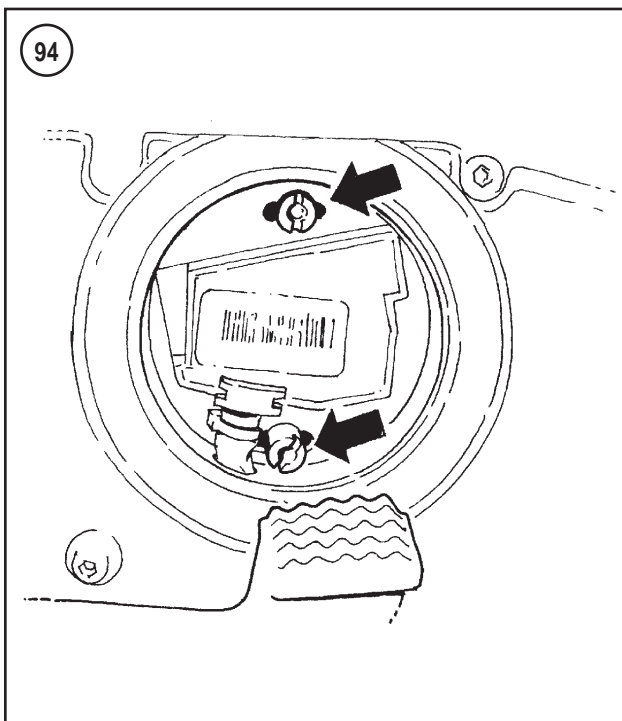
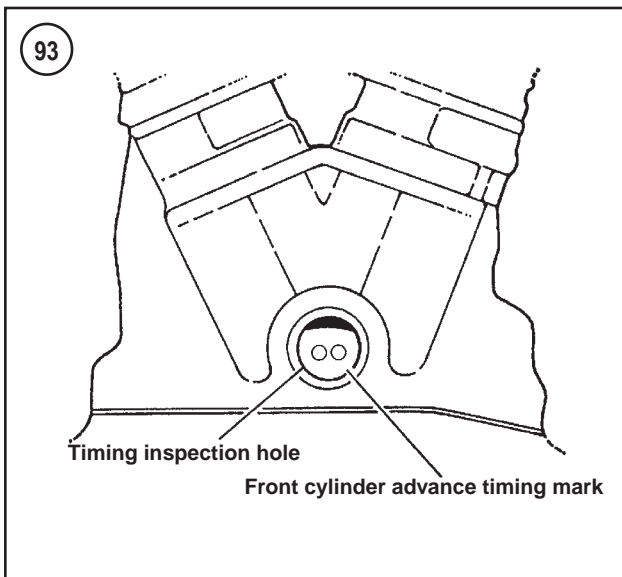
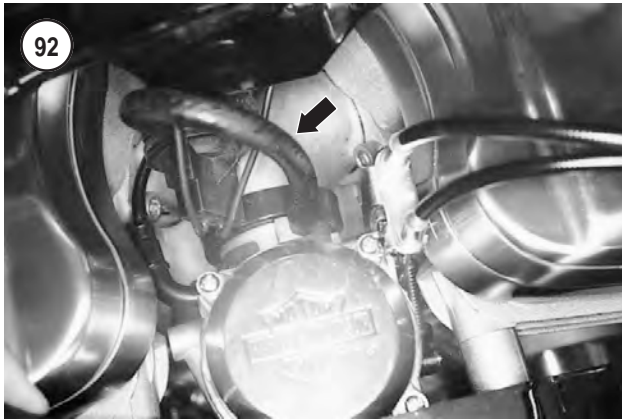

engine idling at 900-950 rpm. Maintain this engine rpm when performing substep e.

- c. On 1991-1992 models, disconnect the VOES vacuum hose from the carburetor (**Figure 92**) with the engine idling at 950-1050 rpm. Maintain this engine rpm when performing substep e.
 - d. On 1993-1994 models, disconnect the VOES vacuum hose from the carburetor (**Figure 92**) with the engine idling at 1650-1950 rpm. Maintain this engine rpm when performing substep e.
 - e. Plug the carburetor VOES port. With the port blocked, the engine speed should decrease and the ignition timing should retard—check with the timing light. When the vacuum hose is reconnected to the VOES port, the engine speed should increase.
 - f. If the engine failed to operate as described in substep e, check the VOES wire connection at the ignition module. Also check the VOES ground wire for looseness or damage. If the wire connections are okay, test the VOES switch as described in Chapter Twelve.
10. Reinstall the timing hole plug (**Figure 89**).
 11. Remove the timing light and tachometer (if used).
 12. Reset the engine idle speed as described in this section.

1995-2003 Models

1. Remove the plug from the timing hole on the right side of the engine (**Figure 89**). A clear plastic viewing plug is available to minimize oil spray. Make sure the plug does not contact the flywheel after installation.
2. On models not equipped with a tachometer, attach a shop tachometer to the engine following the manufacturer's instructions.
3. Connect an inductive clamp-on timing light to the front cylinder spark plug wire following the manufacturer's instructions.
4. Start the engine and allow it to warm to normal operating temperature. Then set idle speed to 950-1050 rpm.
5. Aim the timing light at the timing inspection hole. At 950-1050 rpm, the front cylinder advance mark should appear in the center of the inspection window as shown in **Figure 93**. If the mark does not align, adjust the ignition timing starting with Step 6. If the ignition timing is correct, proceed to Step 9.
6. Remove the sensor plate outer cover, inner cover and gasket, if so equipped, as described in *Ignition System* in Chapter Twelve.
 - 7A. On all models except 1200S models, loosen the timing plate sensor plate screws (**Figure 91**) just enough to allow the plate to rotate.
 - 7B. On 1200S models, loosen the timing plate sensor plate screws (**Figure 94**) just enough to allow the plate to rotate.
8. Start the engine and turn the plate as required so that the advanced mark is aligned as described in Step 5. To adjust

the plate, use a screwdriver in the plate's slot. Make sure idle speed specified in Step 5 is maintained when checking timing. Tighten the screws (**Figure 91** or **Figure 94**) and re-check ignition timing.

9. Install the sensor plate gasket, inner cover and outer cover.

10. As part of the tune-up, check the vacuum operated electric switch (VOES) as follows:

CAUTION

The Vacuum Operated Electric Switch (VOES) must be tested at each tune-up and replaced if malfunctioning. A damaged VOES switch will allow too high a spark advance which can cause severe engine knock and damage.

- a. Start the engine and allow it to idle.
 - b. Disconnect the VOES vacuum hose from the carburetor (**Figure 92**) with the engine idling at 1000-1050 rpm. Maintain this engine rpm when performing substep c.
 - c. Plug the carburetor VOES port. With the port blocked, the engine speed should decrease and the ignition timing should retard—check with the timing light. When the vacuum hose is reconnected to the VOES port, the engine speed should increase.
 - d. If the engine failed to operate as described in substep c, check the VOES wire connection at the ignition module. Also check the VOES ground wire for looseness or damage. If the wire connections are okay, test the VOES switch as described in Chapter Twelve.
11. Reinstall the timing hole plug (**Figure 89**).
 12. Remove the timing light and tachometer (if used).
 13. Reset the engine idle speed as described in this section.

Idle Speed Adjustment

Prior to adjusting the idle speed, make sure the air filter is clean and the engine compression and ignition timing are within specification. Refer to the appropriate section in this chapter.

Idle speed specifications are in **Table 8**.

1986-1987 models

1. Make sure the throttle cable free play is adjusted as described in this chapter.
2. On models not equipped with a tachometer, attach a shop tachometer to the engine following the manufacturer's instructions.
3. Start the engine and let it reach normal operating temperature. The engine must be at normal operating temperature for accurate idle speed adjustment.

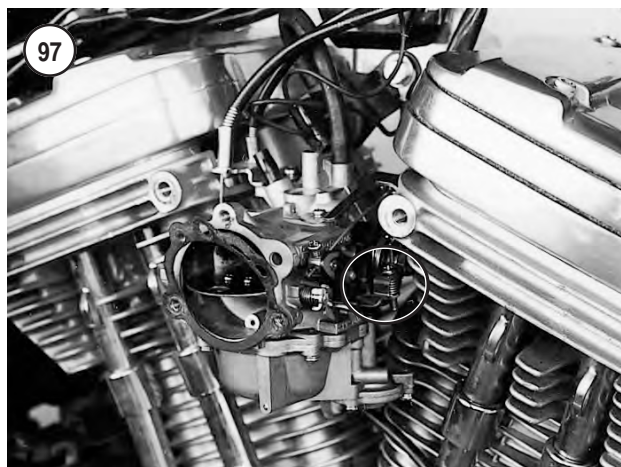
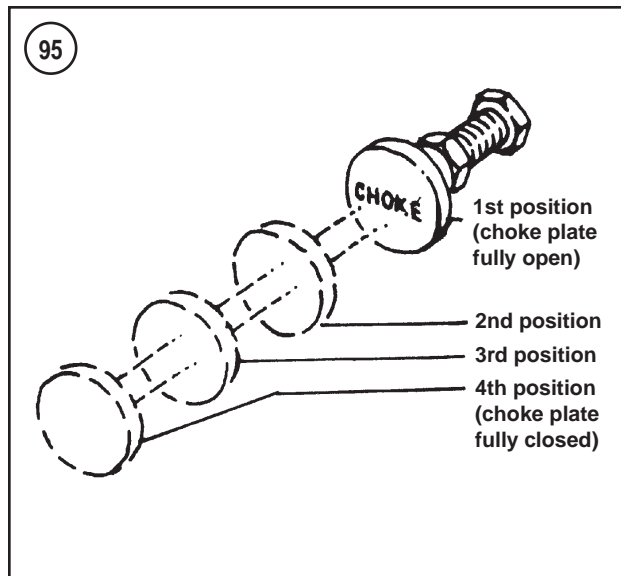

4. Make sure the choke knob (**Figure 95**) is pushed in all the way.
5. On the carburetor turn the idle speed screw (**Figure 96**) in or out to adjust the slow idle speed to within specification.
6. Open and close the throttle a couple of times and check for variations in idle speed. Readjust if necessary.



7. Pull the choke knob to the second detent position. Turn the fast idle screw (**Figure 97**) so the engine idles at 1700-1800 rpm. Push in the choke knob to the closed position and verify that engine idle speed drops to the slow idle speed.
8. Make sure both slow idle and fast idle speeds are within specification noted in **Table 8**.

1988-2003 models

1. Make sure the throttle cable free play is adjusted as described in this chapter.
2. On models not equipped with a tachometer, attach a shop tachometer as described by the manufacturer's instructions.
3. Start the engine and let it reach normal operating temperature. The engine must be at normal operating temperature for the idle speed adjustment to be accurate.
4. Make sure the starting enrichment (choke) knob (**Figure 98**) is pushed in all the way.
5. On the carburetor turn the idle speed screw (**Figure 99**) in or out to adjust the idle speed to within specification.
6. Open and close the throttle a couple of times and check for variations in idle speed. Readjust if necessary.

Table 1 MAINTENANCE SCHEDULE¹

| | |
|--|---|
| <p>Pre-ride check</p> | <p>Check tire condition and inflation pressure Check wheel rim condition Check light and horn operation Check engine oil level; add oil if necessary Check brake fluid level and condition; add fluid if necessary Check the operation of the front and rear brakes Check throttle operation Check clutch lever operation Check fuel level in fuel tank; top off if necessary Check fuel system for leaks Check drive chain or drive belt condition and adjustment Verify proper operation of air cleaner EVAP valve (models so equipped)</p> |
| <p>Every 300 miles (480 km) Initial 1000 miles (800 km)</p> | <p>Lubricate drive chain (models so equipped) Check brake pad wear Check brake disc wear Inspect fuel valve, fuel line and all fittings for leaks Check engine idle speed Check battery fluid level; refill with distilled water Check electrical equipment and switches for proper operation Check throttle operation Operate and check enricher (choke) cable operation Check tire pressure and tread wear Change engine oil and replace oil filter Inspect and clean air filter Check rear drive chain or belt tension; adjust if necessary Inspect primary chain Check primary chain tension; adjust if necessary Change primary drive/transmission oil Check clutch adjustment; adjust if necessary</p> <p>(continued)</p> |

Table 1 MAINTENANCE SCHEDULE¹ (continued)

| | |
|---|--|
| <p>Every 300 miles (480 km) Initial 1000 miles (800 km) (continued)</p> | <p>Check brake fluid level; refill with DOT 5 brake fluid Check rear brake pedal adjustment; adjust if necessary Perform general lubrication to equipment specified in this chapter Check ignition timing Check vacuum operated electric switch (VOES) Check rear swing arm pivot shaft tightness Check engine mount bolt tightness Inspect rear shock absorber Check all exposed fasteners for tightness² Lubricate rear swing arm bearing Lubricate speedometer drive gear (models so equipped) Check steering play adjustment Verify proper operation of air cleaner EVAP valve (models so equipped)</p> |
| <p>Every 2500 miles (4000 km)</p> | <p>Check engine oil level Check primary drive/transmission oil level Check brake pad wear Check brake disc wear Inspect fuel valve, fuel line and all fittings for leaks Check engine idle speed Check battery fluid level; refill with distilled water Check electrical equipment and switches for proper operation Check throttle operation Operate and check enricher cable operation Check tire pressure and tread wear Lubricate speedometer drive gear (models so equipped) Verify proper operation of air cleaner EVAP valve (models so equipped)</p> |
| <p>Initial 5000 miles (8000 km)</p> | <p>Check spark plug gap and condition Check steering play adjustment</p> |
| <p>Every 5000 miles (8000 km)</p> | <p>Change engine oil and replace oil filter Inspect and clean air filter Check rear drive chain or belt tension; adjust if necessary Inspect primary chain Check primary chain tension; adjust if necessary Change primary drive/transmission oil Check clutch adjustment; adjust if necessary Check brake fluid level; refill with DOT 5 brake fluid Check rear brake pedal adjustment; adjust if necessary Perform general lubrication to equipment specified in this chapter Check ignition timing Check vacuum operated electric switch (VOES) Check MAP sensor (1200S) Check rear swing arm pivot shaft tightness Check engine mount bolt tightness Inspect rear shock absorber Check all exposed fasteners for tightness² Lubricate rear swing arm bearing Inspect rear brake caliper mounting pins and boots; lubricate pins and boots during reassembly Inspect and lubricate rear brake and shifter linkage assembly Lubricate throttle control sleeve Lubricate speedometer cable Verify proper operation of bank angle sensor (models so equipped)</p> |
| <p>Every 10,000 miles (16,000 km)</p> | <p>Replace spark plugs Replace front fork oil Lubricate steering bearings Check steering play adjustment Clean and lubricate wheel bearings</p> |

1. Consider this maintenance schedule a guide to maintenance and lubrication intervals. Harder than normal use and exposure to mud, water, high humidity indicates more frequent servicing to most items.
2. Except cylinder head bolts. Cylinder head bolts must be tightened following the procedure in Chapter Four. Improper tightening of the cylinder head bolts may cause cylinder gasket damage.

Table 2 TIRE INFLATION PRESSURE (COLD)¹

| | psi | kPa |
|--|-----|-----|
| Up to 300 lb. load² | | |
| Front | | |
| 1200 models | 30 | 207 |
| 883 and 1100 models | | |
| 1986-1990 | 26 | 179 |
| 1991-2003 | 30 | 207 |
| Rear | | |
| 1200 models | 36 | 248 |
| 883 and 1100 models | | |
| 1986-1990 | 30 | 207 |
| 1991-2003 | 36 | 248 |
| Up to GVWR maximum load³ | | |
| Front | | |
| 1200 models | 30 | 207 |
| 883 and 1100 models | | |
| 1986-1990 | 26 | 179 |
| 1991-2003 | 30 | 207 |
| Rear | | |
| 1200 models | 40 | 276 |
| 883 and 1100 models | | |
| 1986-1990 | 32 | 221 |
| 1991-2003 | 40 | 276 |

1. Tire inflation pressure is for original equipment tires. Aftermarket tires may require a different inflation pressure.
 2. 300 lb. load includes rider, passenger and cargo.
 3. The gross vehicle weight rating (GVWR) is listed on a decal mounted on the frame.

Table 3 ENGINE OIL SPECIFICATIONS

| Type | HD rating | Viscosity | Ambient operating temperature |
|--------------------|-----------|------------|-------------------------------|
| H-D Multi-grade | HD360 | SAE 10W/40 | Below 40° F |
| H-D Multi-grade | HD360 | SAE 20W/50 | Above 40° F |
| H-D Regular heavy* | HD360 | SAE 50 | Above 60° F |
| H-D Extra heavy* | HD360 | SAE 60 | Above 80° F |

*Not recommended for use when ambient temperature is below 50° F.

Table 4 ENGINE AND PRIMARY DRIVE/TRANSMISSION OIL CAPACITIES

| | |
|--|-----------------|
| Oil tank refill capacity with filter replacement | 3.0 qt (2.8 L) |
| Transmission (includes primary chaincase) | |
| 1986-1992 models | 24 oz (710 ml) |
| 1993-2003 models | 32 oz. (946 ml) |

Table 5 RECOMMENDED LUBRICANTS AND FLUIDS

| | |
|----------------------|--|
| Brake fluid | DOT 5 |
| Chain lubricant | |
| Standard drive chain | H-D Chain Spray or HD High-Performance Chain Lube |
| O-ring drive chain | H-D High-Performance Chain Lube or automotive lubricant rated API GL-5 with a viscosity index of SAE 80 or 90. |
| Front fork oil | H-D Type E or equivalent |
| Fuel | |
| Type | Unleaded |
| Octane | |
| 1986-1990 models | Pump research octane of 89 or higher |
| 1991-2003 models | Pump research octane of 87 or higher |
| Transmission | H-D Sport Trans Fluid or equivalent |

Table 6 FRONT FORK OIL CAPACITY

| | Wet | | Dry | |
|-------------------|------|-----|------|-----|
| | oz | ml | oz | ml |
| 1986-1987 models | 5.4 | 160 | 6.4 | 189 |
| 1988-1991 models | 9.0 | 266 | 10.2 | 302 |
| 1992-1998 | | | | |
| 883 Hugger models | 10.7 | 316 | 12.1 | 358 |
| All other models | 9.0 | 266 | 10.2 | 302 |
| 1999-2003 models | 9.0 | 266 | 10.2 | 302 |

Table 7 MAINTENANCE AND TUNE-UP SPECIFICATIONS

| Item | Specification |
|-------------------------------|------------------------------------|
| Brake pad minimum thickness | 0.062 in. (1.59 mm) |
| Clutch cable free play | 1/16-1/8 in. (1.6-3.2 mm) |
| Drive belt deflection | |
| 1991-1999 models | 9/16-11/16 in. (14.3-17.5 mm) |
| 2000-2003 models | |
| 883, 1200, 1200S models | 5/16-3/8 in. (7.9-9.6 mm) |
| 883H and 883C models | 1/4-5/16 in. (6.4-7.9 mm) |
| Drive chain | No. 530 (3/8 in. wide) × 110 links |
| Drive chain free play* | 1/4 in. (6.4 mm) |
| Engine compression (min.) | 120 psi (828 kPa) |
| Idle speed | |
| 1986-1987 models | |
| Slow idle | 900-950 rpm |
| Fast idle | 1500-1500 rpm |
| 1988-2003 models | 1000-1050 rpm |
| Primary chain free play | |
| Cold engine | 3/8-1/2 in. (9.6-12.7 mm) |
| Hot engine | 1/4-3/8 in. (6.4-9.6 mm) |
| Spark plugs | HD-6R12 |
| Gap | 0.038-0.043 in. (0.97-1.09 mm) |
| Tire wear/maximum tread depth | 1/16 in. (1.6 mm) |

*Rider on seat.

Table 8 IGNITION TIMING SPECIFICATIONS

| Year/Idle speed | VOES Connected | VOES Disconnected |
|--|----------------|-------------------------|
| 1986-1994 | | |
| Fast: 1650-1750 rpm | 40° BTDC | Approximately 16° BTDC |
| Normal: 950-1050 rpm | 30° BTDC | Approximately 7.5° BTDC |
| 1995 U.S. models | | |
| 1650-1950 rpm | 35° BTDC | Approximately 16° BTDC |
| 1995 HDI models | | |
| 1000-1050 rpm | 20° BTDC | Approximately 7.5° BTDC |
| 1996-2003 models (except 1998-2003 1200S models) | | |
| 1000-1050 rpm | 20° BTDC | Approximately 7.5° BTDC |
| 1998-2000 1200S models* | | |
| 1000-1050 rpm | 20° BTDC | |
| 2001-2003 1200S models* | | |
| 1000-1050 rpm | 15° BTDC | |

*Not equipped with VOES.

Table 9 MAINTENANCE AND TUNE UP TORQUE SPECIFICATIONS

| Item | ft.-lb. | in.-lb. | N•m |
|---|---------|---------|-------|
| Air filter cover | – | 36-60 | 4-7 |
| Front fork cap* | 11-22 | – | 15-30 |
| Primary chain adjuster locknut | | | |
| 1986-1990 models | – | 98-144 | 11-16 |
| 1991-2003 models | 20-25 | – | 27-34 |
| Primary drive inspection cover retaining screws | – | 84-108 | 10-12 |
| Rear axle nut | 60-65 | – | 81-88 |
| Spark plug | 11-18 | – | 15-24 |
| Transmission/primary chaincase drain plug | 14-21 | – | 19-28 |

*1200S models. No specification available on other models.

CHAPTER FOUR

ENGINE TOP END

This chapter covers the rocker covers, rocker arms, cylinder heads, valves, cylinder blocks, pistons, piston rings and oil tank.

Tables 1-4 are located at the end of this chapter.

TOOLS

Engine service requires a number of special tools. These tools and their part numbers are listed with the individual procedures. For a complete list of the special tools mentioned in this manual, refer to **Table 12** in Chapter One.

When purchasing tools from a dealership or parts supplier, be sure to specify the tools required are for the specific Sportster model being worked on. Many of the tools are specific to the engine. Tools for other engine models may be slightly different.

The manufacturer's part number is provided for many of the tools mentioned in this manual. These part numbers are correct at the time of original publication. The publisher cannot guarantee the part number or the tools in this manual will be available in the future.

ROCKER COVER ASSEMBLY

The rocker cover assembly (**Figure 1**) consists of the outer rocker cover, middle rocker cover and inner rocker cover, which contains the rocker arms and shafts.

The rocker covers can be removed from either cylinder with the engine installed in the frame.

Rocker cover

Removal

Refer to **Figure 1**.

1. Remove the fuel tank as described in Chapter Ten or Chapter Eleven.
2. Remove the air filter and backplate as described in Chapter Ten or Chapter Eleven.
3. If removing the rocker cover on the front cylinder, remove the ignition coil as described in Chapter Twelve.

NOTE

Some rocker cover bolts have a captive washer. Note their position so they can be installed in the correct location

4. Remove the upper rocker arm cover bolts (A, **Figure 2**), steel washers (if used) and fiber washers. See **Figure 3**.
5. Remove the upper rocker arm cover (B, **Figure 2**).
6. Remove the gasket (A, **Figure 4**).
7. Remove the middle rocker arm cover (B, **Figure 4**).
8. Remove and discard the inner and outer gaskets (**Figure 5**).

NOTE

Steps 9A and 9B describe two methods for turning the engine over by hand. When performing Step 9A, the motorcycle must be supported with the rear wheel off the ground.

- 9A. Shift the transmission into fifth gear. While watching the rocker arms, turn the rear wheel until both valves are closed on the cylinder being serviced.
- 9B. Remove the primary cover as described in Chapter Six or Chapter Seven. While watching the rocker arms, turn the engine sprocket nut until both valves are closed on the cylinder being serviced.
10. Loosen, then remove the two rocker arm mounting bolts and washers next to the pushrods (**Figure 6**).
11. Remove the remaining lower rocker arm cover mounting bolts and washers (**Figure 7**).
12. Remove the lower rocker arm cover (**Figure 8**). Discard the gaskets.
13. Remove and discard the fiber washers, which may remain in the cover bolt recesses on the top of the rocker cover.

Installation

NOTE

On 2003 models a one-piece gasket is used in place of the two gaskets identified in Step 1A or 1B.

NOTE

On 1986 models, record the crankcase number on the right crankcase half. The number is located above the point where the oil filter hoses connect to the oil pump. Starting with crankcase number 1786 127 043 (883 cc) or number 1886 127 001 (1100 cc), new style hydraulic tappets were installed. If the center number is 126 or less, perform Step 1A. If the center number is 127 or higher, perform Step 1B. On all 1987-2003 models, perform Step 1B.

- 1A. Perform the following in order:
 - a. Install new lower rocker arm cover gaskets with the bead facing up. Refer to **Figure 9**.
 - b. Install the lower rocker arm cover (**Figure 10**).
 - c. Refer to **Figure 1**. Install bolts 9, 13, 15 and 20.
 - d. Tighten bolts 9 and 15 (5/16 in.) in a crisscross pattern to 15-18 ft.-lb. (20-24 N•m).
 - e. Tighten bolts 13 and 20 (1/4 in.) in a crisscross pattern to 120-156 in.-lb. (14-18 N•m).

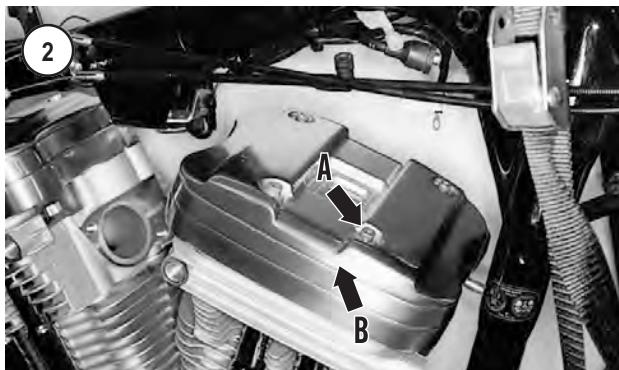
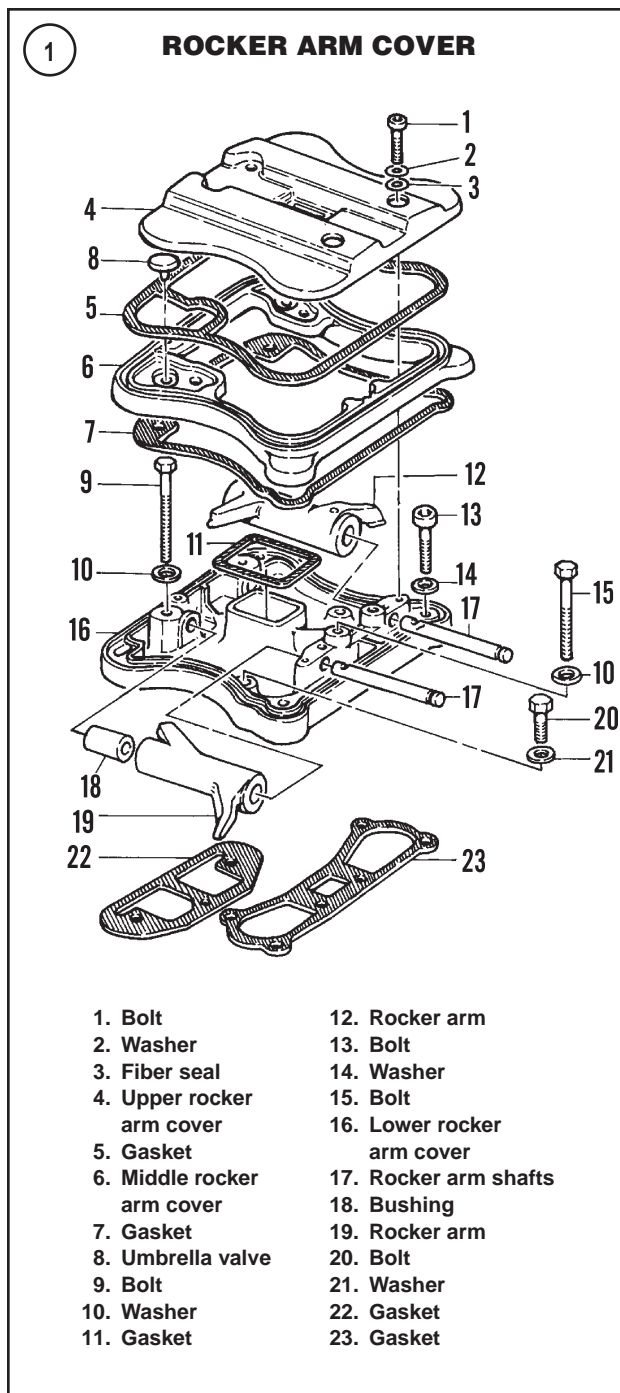

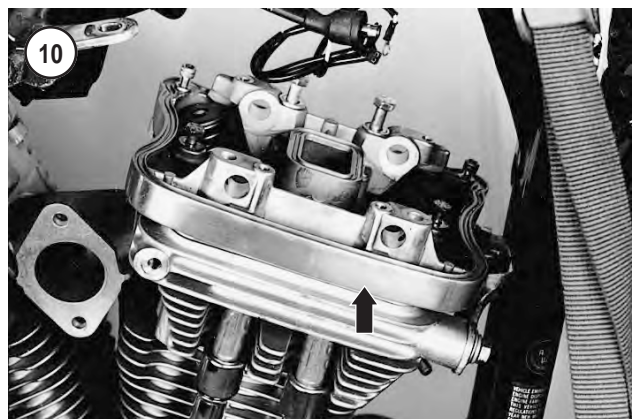
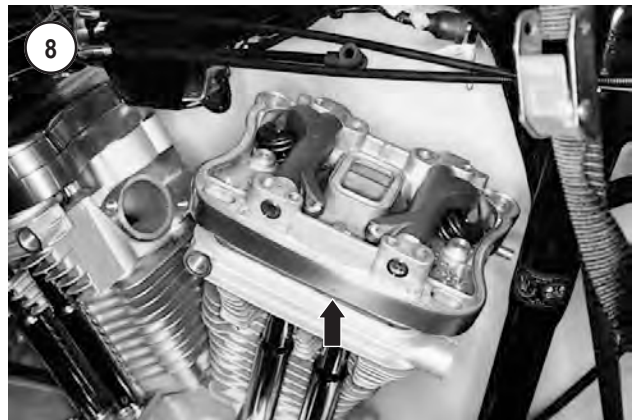
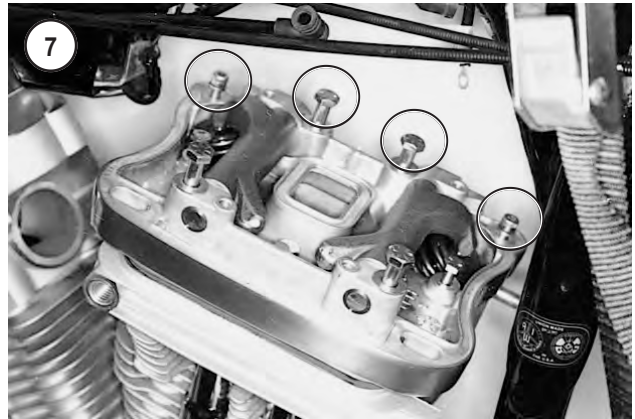

- f. Rotate the engine so that the tappets for the cylinder being serviced are at the lowest position.

NOTE

If the pushrods were removed, refer to the cylinder head installation section in this chapter and install the pushrods.

NOTE

A piece of wire 13-14 in. (330-356 mm) long with a diameter of 0.050-0.060 in. (1.3-1.5 mm) is required for the next step. Fine wire of this type can be purchased at hobby shops or hardware stores.

- g. Remove the bolts (9, **Figure 1**).
- h. Insert the wire through the pushrod and depress the check valve in the tappet (**Figure 11**) while pushing the pushrod down.

NOTE

The rocker arm shafts have cutouts in them. The cutouts must align with the rocker cover bolt holes.

- i. Remove the wire while keeping the tappet depressed with the pushrod and install the rocker arm (A, **Figure 12**) and shaft (B).
- j. Install the bolts (9, **Figure 1**), and tighten to 15-18 ft.-lb. (20-24 N•m).

1B. Perform the following in order:

- a. Rotate the engine so that the tappets for the cylinder being serviced are at the lowest position.

NOTE

If the pushrods were removed, refer to the cylinder head installation section in this chapter and install the pushrods.

- b. Install new lower rocker arm cover gaskets with the bead facing up. See **Figure 9**.

NOTE

The rocker arm shafts have cutouts in them. The cutouts must align with the rocker cover bolt holes.

- c. Install the rocker arms and rocker arm shafts into the lower rocker arm cover.
- d. Install the rocker arm cover assembly (**Figure 8**).
- e. Align the pushrods with the rocker arm sockets.
- f. Refer to **Figure 1**. Install bolts 9, 13, 15 and 20.
- g. Tighten bolts 9 and 15 (5/16 in.) in a crisscross pattern to 15-18 ft.-lb. (20-24 N•m).
- h. Tighten bolts 13 and 20 (1/4 in.) in a crisscross pattern to 120-156 in.-lb. (14-18 N•m).

CAUTION

On all models, make sure the pushrods can be hand-turned before rotating the engine.

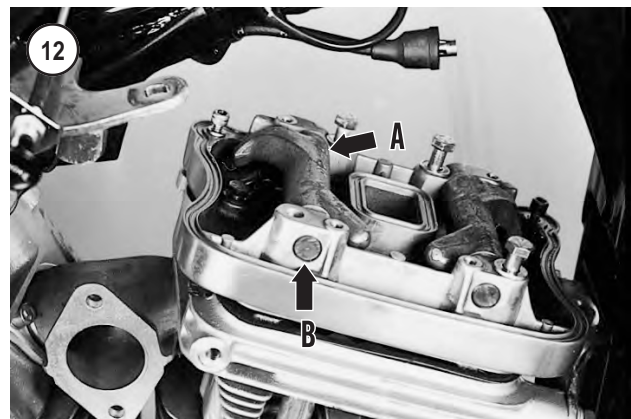
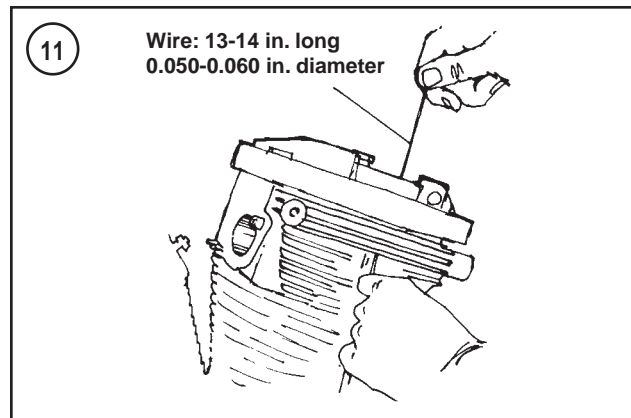

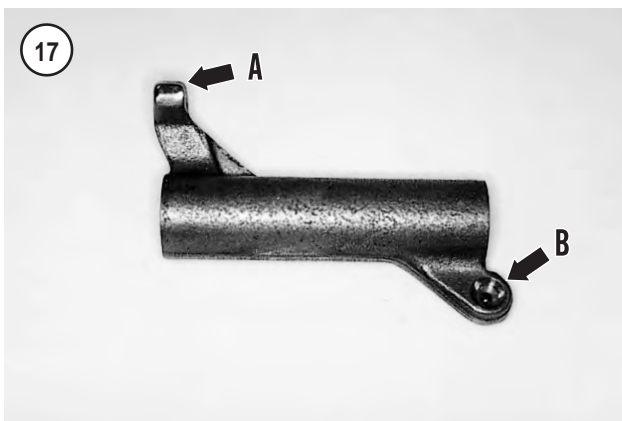
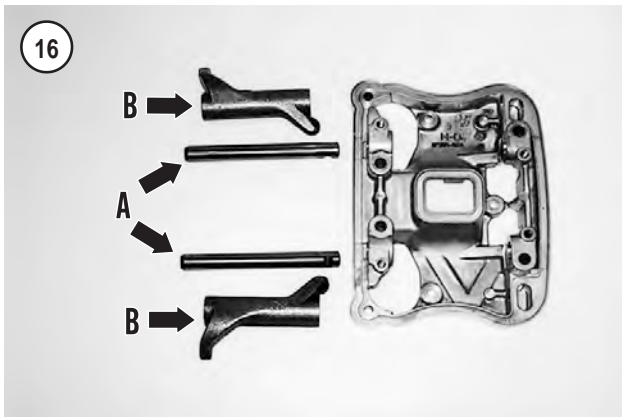

2. Install new center and outer gaskets (**Figure 5**) onto the lower rocker arm cover.
3. Install the middle rocker cover (A, **Figure 13**) onto the lower rocker cover.
4. Install a new gasket (B, **Figure 13**) onto the middle rocker cover.
5. Install the upper rocker cover (**Figure 14**) onto the middle rocker cover.
6. Place a steel washer if used and fiber washer onto each rocker cover mounting bolt (**Figure 3**).
7. Install the rocker cover mounting bolts and tighten to 120-156 in.-lb. (14-18 N•m).
8. Repeat the procedure for the remaining rocker cover assembly.
9. If removed, install the ignition coil as described in Chapter Twelve.
10. Install the air filter and backplate as described in Chapter Ten or Chapter Eleven.
11. Install the fuel tank as described in Chapter Ten or Chapter Eleven.

Removal/inspection/installation

Label all parts prior to disassembly so they may be installed in their original positions. Refer to **Figure 1**.

1. Before removing the rocker arms, measure rocker arm end clearance as follows:
 - a. Insert a feeler gauge between the rocker arm and the inside rocker arm cover boss as shown in **Figure 15**.
 - b. Record the measurement.
 - c. Repeat for each rocker arm.
 - d. Replace the rocker arm and/or the lower rocker cover if the end clearance exceeds the service limit in **Table 2**.
2. Using a soft-faced punch, tap each rocker arm shaft (A, **Figure 16**) out of the lower rocker arm cover.
3. Remove the rocker arms (B, **Figure 16**).
4. Clean the rocker covers, rocker arms and shafts in solvent. Then clean with hot, soapy water and rinse with clear, cold water. Dry with compressed air.
5. Blow compressed air through all the oil passages to make sure they are clear.
6. Examine the rocker arm pads (area that contacts the valve). See A, **Figure 17**. The pad on each rocker arm should be shiny and convex—curving outward. Replace the rocker arm if the pad shows signs of pitting, grooves or excessive wear.
7. Examine the rocker arm socket (area that retains the pushrod). See B, **Figure 17**. The socket will show wear but it should be smooth without any sign of a step or lip. Replace the rocker arm if the socket is severely worn, cracked or has a step or lip.
8. Examine the rocker arm shaft (**Figure 18**) for scoring, ridge wear or other damage. If these conditions are present, replace the rocker arm shaft. If the shaft does not show any visual wear or damage, perform Step 9.

9. Measure the rocker arm shaft outside diameter (**Figure 19**) where it rides in the rocker arm and in the lower rocker arm cover. Record both measurements.

10. Measure the rocker arm bushing inside diameter (**Figure 20**) and the lower rocker arm cover bore diameter where the shaft rides (**Figure 21**). Record both measurements.

11. Subtract the measurements taken in Step 9 from those in Step 10 to obtain the following rocker arm shaft clearance measurements:

- a. Shaft fit in rocker cover.
- b. Shaft fit in rocker arm bushing.

12. Replace the rocker arm bushings or the lower rocker arm cover if the clearance exceeds the specifications in **Table 2**. Also, replace any parts which are worn beyond the service limit specification in **Table 2**. Rocker arm bushing replacement is described in this section.

NOTE

*On 1986 models specified in the NOTE under **Installation** in this section, the rocker arms are not installed until the lower rocker cover has been installed on the cylinder head. Disregard the following steps.*

13. Install the rocker arms into their original positions (**Figure 22**).

14. Align the notch (A, **Figure 23**) in the rocker arm shaft with the bolt hole (B) in the lower rocker arm cover and install the rocker arm shaft. Repeat for the opposite rocker arm shaft. See **Figure 24**.

Bushing replacement

Each rocker arm is equipped with two bushings (**Figure 20**). Replacement bushings must be reamed using the rocker arm bushing reamer (part No. HD-94804-57).

NOTE

Because new bushings must be reamed, remove only one bushing at a time. The opposite bushing will be used as a guide when reaming the first bushing.

1. Press or drive one of the bushings from the rocker arm (**Figure 20**). Do not remove the second bushing. If the bushing is difficult to remove, perform the following:

- a. Thread a 9/16-18 in. tap into the bushing to be removed.
- b. Support the rocker arm in a press so that the tap is at the bottom.
- c. Insert a mandrel through the top of the rocker arm and seat it on top of the tap.
- d. Press on the mandrel to force the bushing/tap out of the rocker arm. Don't let the tap fall.
- e. Remove the tap from the bushing and discard the bushing.

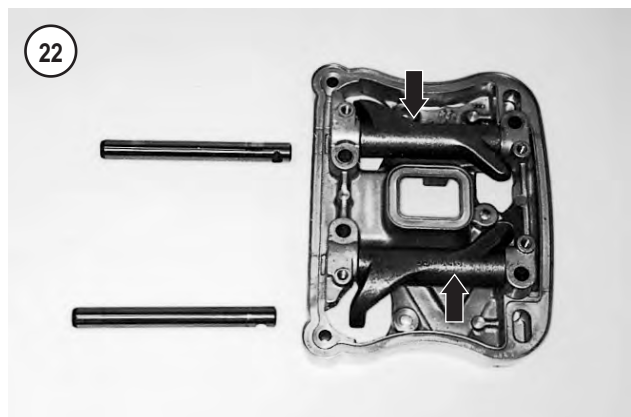
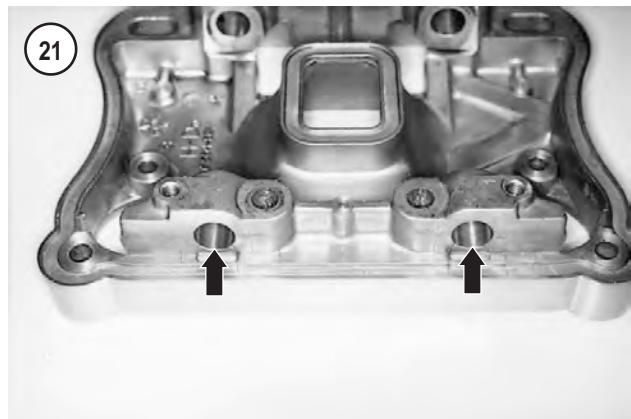

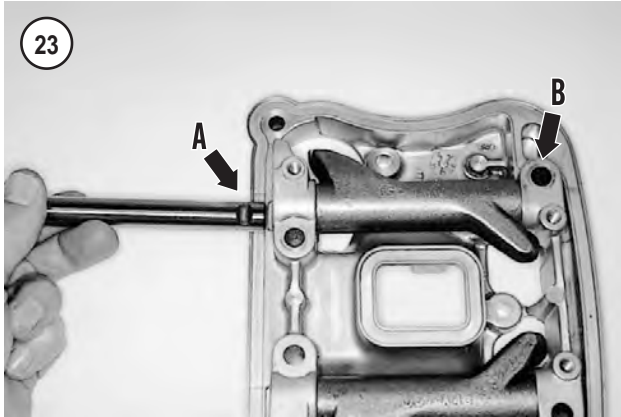

2. Position a new bushing so the split portion faces the top of the rocker arm. Press in the new bushing until its outer surface is flush with the rocker arm bore inside surface (**Figure 20**).

3. Ream the new rocker arm bushing using the rocker arm bushing reamer as follows:

- a. Mount the rocker arm in a vise with soft jaws so that the new bushing is at the bottom.

CAUTION

The reamer must be turned clockwise only. Do not turn the reamer counterclockwise or the reamer may be damaged.

- b. Mount a tap handle on top of the reamer and insert the reamer into the bushing. Turn the reamer clockwise until it passes through the new bushing and remove it from the bottom side. The old bushing left in the rocker arm is used as a guide for the reamer.

4. Remove the rocker arm from the vise and repeat Steps 1-3 to replace the second bushing. The first bushing will now act as a guide for the reamer.

5. When both bushings have been replaced and reamed, clean the rocker arm and bushings in solvent. Clean with hot, soapy water and rinse with clear and cold water. Dry with compressed air.

6. Measure the inside diameter of each bushing with a snap gauge. When properly reamed, the bushings should provide 0.0005-0.0020 in. (0.012-0.050 mm) shaft clearance.

CYLINDER HEAD

Removal

1. Remove the exhaust system as described in Chapter Ten or Chapter Eleven.

2. Remove the air filter assembly and backplate as described in Chapter Ten or Chapter Eleven.

3. On 1986-1994 models, disconnect the ignition switch wires and remove the ignition switch as described in Chapter Twelve. Remove the choke knob bracket (**Figure 25**) as described in Chapter Ten.

4. Disconnect the spark plug wires and set them out of the way.

5. Remove the ignition coil as described in Chapter Twelve.

6. On 1995-2003 models, remove the choke knob bracket mounting screw. Secure the knob so it is out of the way.

7. On all models except 1998-2003 1200S models, remove the vacuum hose (**Figure 26**) from the VOES fitting on the carburetor, and disconnect the VOES electrical connector at the ignition module as described in Chapter Twelve.

8. Remove the carburetor as described in Chapter Ten or Chapter Eleven.

9. Remove the top center engine mount (**Figure 27**) as follows:

27

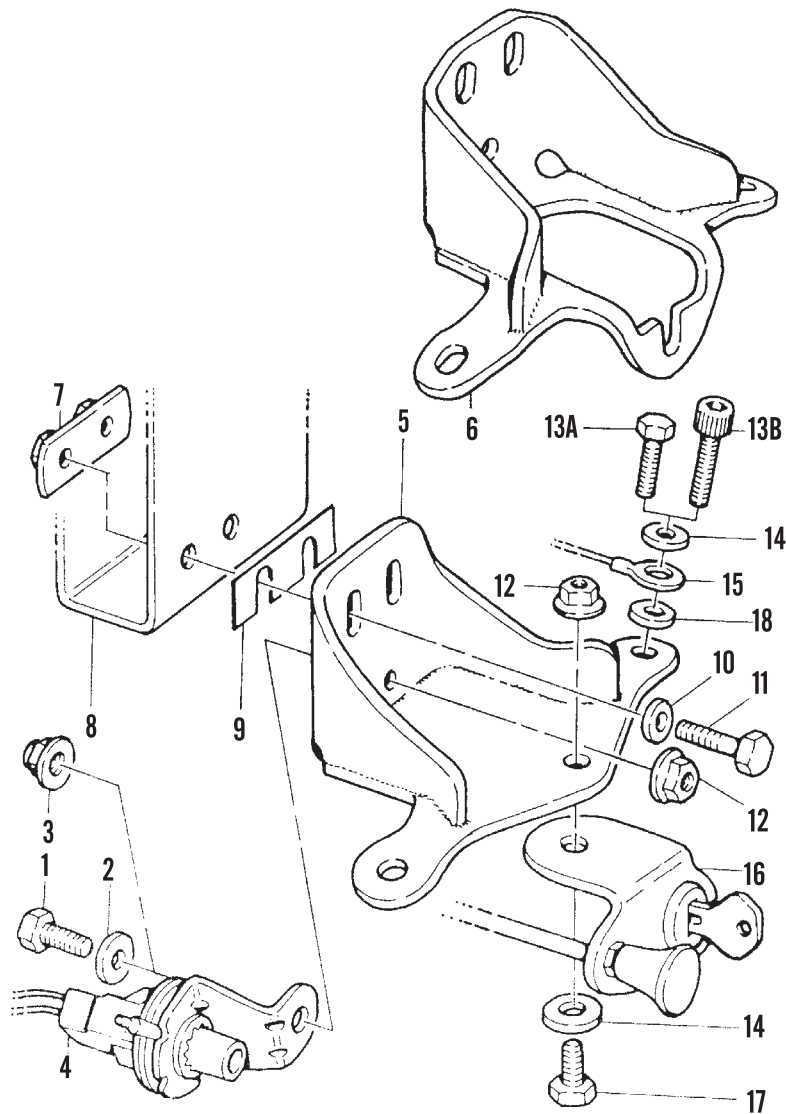
TOP CENTER ENGINE MOUNT

1. Bolt
2. Washer (1986-1991 models)
3. Locknut (1992-2003 models)
4. Vacuum-operated electric switch (all models except 1998-2003 1200S models)
5. Top center engine bracket (1986-1994 models)
6. Top center engine bracket (1995-2003 models)
7. Nut plate
8. Frame
9. Shim

10. Washer
11. Bolt
12. Locknut
- 13A. Bolt (1986-1991 models)
- 13B. Bolt (1992-2003 models)
14. Lockwasher (1986-1994 models)/ Washer (1995-2003 models)
15. VOES ground wire (1986-1993 models)
16. Ignition bracket (1986-1994 models)
17. Bolt
18. Washer (1986-1994 models)



- a. Remove the bolts, washers and lockplate securing the top center engine mount to the frame. Check for a shim (9, **Figure 27**) mounted between the top center engine mount and frame; this shim is not used on all models.
- b. Remove the choke knob (**Figure 28**) if it was not removed with the carburetor.
- c. Loosen the Allen bolts securing the top center engine mount to the cylinder heads.
- d. Remove the Allen bolts (A, **Figure 29**), flat washers and lockwashers.
- e. On 1986-1993 models, remove the VOES ground wire (**Figure 30**) when removing the rear cylinder

head bolt and set the wire aside. Check the VOES wire for damage. Repair the wire or connector, if necessary, before reinstalling the cylinder heads.

- f. Remove the top center engine mount (B, **Figure 29**) and shim (if used).
10. Remove the top front engine mount (**Figure 31**) as follows:
 - a. Pry off the side reflectors (**Figure 32**) from the front frame tubes. See **Figure 33**.
 - b. Loosen then remove the bolts (A, **Figure 34**) and washers securing the top front engine mount to the frame mounting bracket. Remove the nut plate (5, **Figure 31**) from the frame mounting bracket.
 - c. Loosen the bolt (B, **Figure 34**) and nut securing the top front engine mount to the front cylinder block.
 - d. Remove the bolt, nut, lockwashers and flat washers.
 - e. Remove the top front engine mount (C, **Figure 34**).
 11. Remove the spark plugs (Chapter Three).
 12. On 1986-1990 models, remove the pushrod spring cap retainer by prying outward (**Figure 35**).
 13. Remove the rocker covers as described in this chapter.
 14. Label and then remove both pushrods (A, **Figure 36**).
 15. Remove the intake manifold as described in Chapter Ten or Chapter Eleven.

CAUTION

Failure to loosen and remove the cylinder head mounting bolts properly can damage the cylinder head and cylinder studs.

16. Loosen the cylinder head mounting bolts 1/8 turn at a time in the order shown in **Figure 37**. Continue loosening the bolts 1/8 turn at a time until they are all loose. Then remove the bolts and washers.
17. Lift the cylinder head (B, **Figure 36**) off the cylinder. If the head is tight, tap it with a soft-faced hammer, then remove it.
18. Remove and discard the cylinder head gasket (**Figure 38**).
19. Remove the O-rings around the cylinder dowel pins. Discard the O-rings.
20. If necessary, service the pushrod assemblies as described in this chapter.
21. To remove the valve tappets, refer to *Valve Tappets* in Chapter Five.

Inspection

1. Remove the exhaust gasket from the cylinder head.
2. Remove and inspect the valves and valve seals as described in *Valves and Valve Components* in this chapter. Fabricate a cardboard or wooden holder to store the valves as they are removed.
3. Clean the cylinder head. A thorough cleaning is required to inspect the cylinder head accurately for wear and damage. Because of cylinder head construction, materials and

31

TOP FRONT ENGINE MOUNT

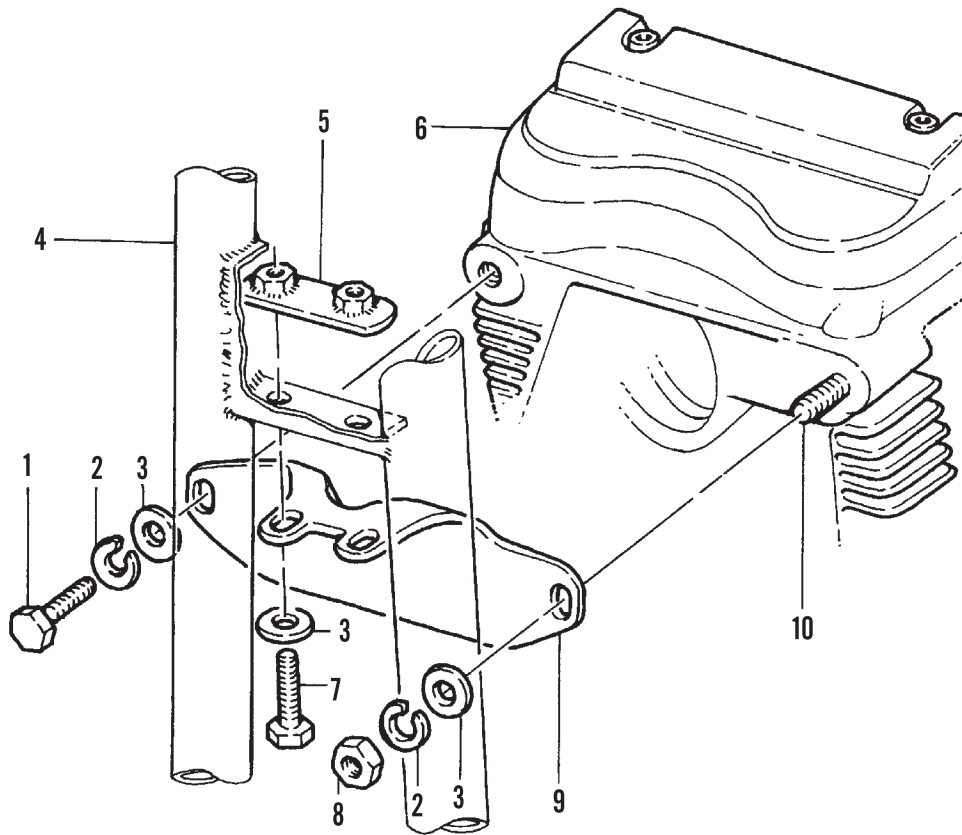

1. Bolt
2. Lockwasher
3. Washer
4. Frame downtube
5. Nut plate
6. Engine
7. Bolt
8. Nut
9. Top front engine bracket
10. Stud



32



33

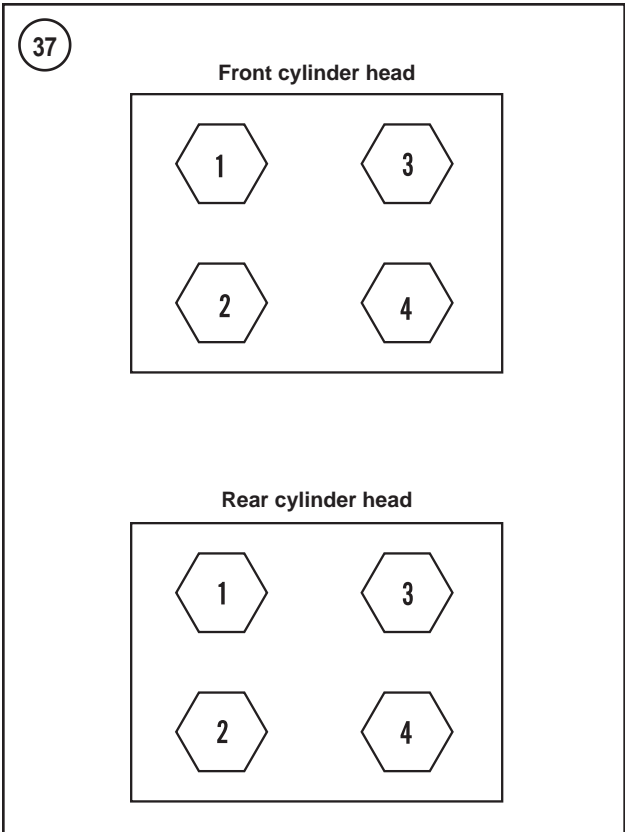
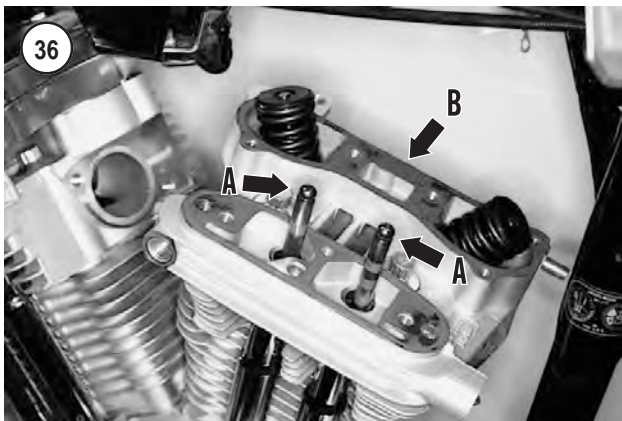

operating conditions, different cleaning techniques and procedures will be required.

- a. First scrape the upper and lower gasket surfaces. Work slowly and carefully, making sure not to scratch or gouge these surfaces. Damage could cause the head to leak when it is returned to service.

CAUTION

Use only solvent or cleaners that are compatible with aluminum parts.

- b. Soak the head in a solvent tank. This will help to soften the carbon buildup in the combustion chambers and exhaust port and to remove oil and grease

from the head surfaces. If a solvent tank is not available, spray the head with an aerosol cleaner, following the manufacturer's instructions. Then wash the head in hot, soapy water and rinse with clear, cold water. Dry with compressed air.

CAUTION

Do not use a power-driven wire brush to clean the combustion chambers (Figure 39). The bristles may leave scratches that could become hot spots when the head is returned to service.

- c. Bead-blasting is the most efficient way of removing deposits from the combustion chamber. If scraping

the combustion chambers, work carefully around the valve seats. A damaged or slightly scratched valve seat will cause poor valve seating.

CAUTION

After bead-blasting a head, clean it thoroughly to remove all blasting residue. The residue collects easily in corners and pockets and is difficult to remove. A bead-blasted head should be initially washed and soaked in a solvent tank, cleaned with hot soapy water, rinsed in cold water and then dried with a thorough blasting of compressed air. Blasting residue that is not removed will enter the lubrication system and cause rapid engine wear.

4. Place a straightedge across the gasket surface at several points (**Figure 40**). Measure warp by inserting a feeler gauge between the straightedge and cylinder head at each location. If the warp meets or exceeds the service limit in **Table 2**, have the head resurfaced or replace it.

5. Examine the spark plug threads in the cylinder head for damage. If damage is minor or if the threads are dirty or clogged with carbon, use a spark plug thread tap (**Figure 41**) to clean the threads following the manufacturer's instructions. If thread damage is severe and cannot be repaired with the thread tap, install the correct size steel insert from a spark plug repair kit.

6. Check for cracks in the combustion chamber, exhaust port (**Figure 42**) and valve guide (**Figure 43**). If a crack is found, refer the repair to a dealership or replace the cylinder head.

7. Measure the rocker arm shaft bore diameter as described in *Rocker Cover Assembly* in this chapter.

8. Inspect the pushrods as described in *Pushrods and Covers* in this chapter.

9. Inspect the following components as described in *Valves and Valve Components* in this chapter:

- a. Valve guides.
- b. Valve springs.
- c. Valve seats.
- d. Valves.

10. After the cylinder head has been thoroughly cleaned of all carbon, valve grinding compound and bead-blasting residue, install new valve guides (if necessary), valve seals, valve springs and valves as described in *Valves and Valve Components* in this chapter.

Installation

1. If removed, install the cylinder dowel pins (**Figure 44**).
2. Install new O-rings around the cylinder dowel pins (**Figure 45**).

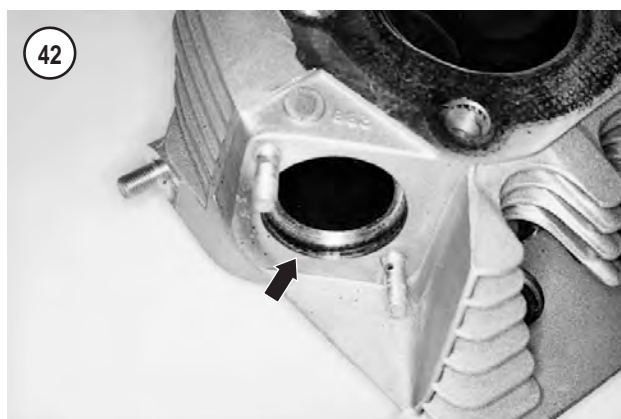
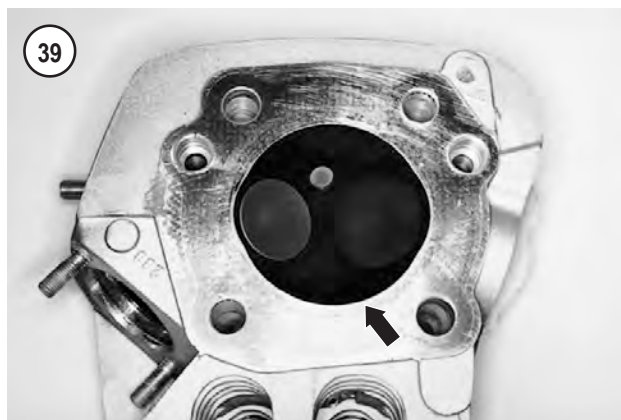

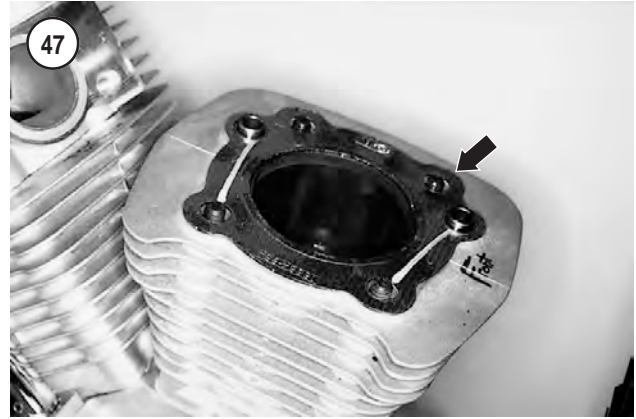

4

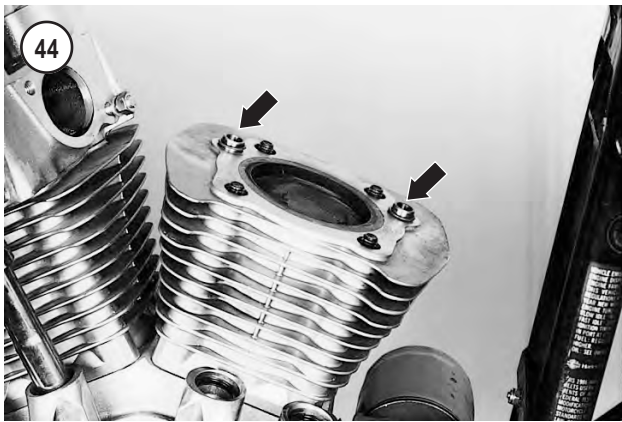
**CAUTION**

Be sure the head gasket fits around the dowel pin O-rings (**Figure 45**). Otherwise, the O-ring may leak.

3. If removed, install the pushrod cover assemblies. Install a new O-ring at the top of each pushrod cover.
4. Lubricate the cylinder studs and cylinder head bolts as follows:
 - a. Clean the cylinder studs and cylinder bolts.
 - b. Apply clean engine oil to the cylinder stud threads and to the flat shoulder surface on the cylinder head bolts (**Figure 46**).
 - c. Remove all excess oil from both parts with a lint-free cloth or compressed air. An oil film is all that is necessary on these surfaces.

CAUTION

Excessive oil left on the cylinder studs can collect inside the top of cylinder head bolt, causing an oil lock and preventing the bolt from being correctly torqued. This will cause a blown head gasket and oil leak.

CAUTION

An overhaul gasket set may include cylinder head gaskets for more than one engine size. If the gaskets are not identified, contact the parts manufacturer. Be sure to install the correct gasket.

5. Remove the horn (Chapter Twelve).
6. Install a new cylinder head gasket (**Figure 47**).

CAUTION

Do not apply any type of sealer on original equipment head gaskets. If using an after-market head gasket, follow the manufacturer's instructions for gasket installation.

NOTE

Cylinder heads can be identified by the **FRONT** or **REAR** marks cast into the head; see **Figure 48**.

7. Install the cylinder head onto the cylinder dowel pins and studs. Position the head so the the head gasket is not moved out of alignment.
8. Install the cylinder head bolts and install them finger-tight. Install the long bolts in the center bolt holes. Install the short bolts in the outer bolt holes next to the spark plug hole.

CAUTION

Failure to follow the torque pattern and sequence in Step 8 may cause cylinder head distortion and leaks.

9. Tighten the cylinder head bolts as follows:
 - a. Tighten bolt No. 1 to 84-108 in.-lb. (9-12 N•m). Then continue and tighten bolts, 2, 3 and 4 in numerical order. **Figure 49** identifies the bolt numbers for the front and rear cylinder heads.
 - b. Tighten bolt No. 1 to 144-168 in.-lb. (16-19 N•m). Then continue and tighten bolts 2, 3 and 4 in numerical order.
 - c. On 1998-2003 models, loosen all the bolts and repeat substeps a and b.
 - d. Make a mark on the No. 1 bolt head and a matching mark on the cylinder head. Repeat for each bolt. See **Figure 50**.
 - e. Following the tightening sequence in **Figure 49**, turn each bolt head 1/4 turn (90°) clockwise (**Figure 51**), using the match marks as a guide.
 - f. Repeat for the remaining cylinder head.

CAUTION

If a valve train component has been replaced or if the cylinder head, valves and seats have been reconditioned or replaced, the length of each pushrod must be checked and adjusted. This procedure should be referred to a dealership as special tools are required. In addition, the pushrods must be installed in their original positions by following the marks made during disassembly. If the pushrods were not marked, the length must be checked by a dealership.

10A. On 1986-1990 models, install the pushrods in their original positions if they were labeled during removal and the cylinder head, valves or seats were not reconditioned or replaced.

10B. On 1991-2003 models, install the pushrods in their original positions if they were labeled during removal. If the pushrods were not labeled, or new pushrods are being installed, identify them as follows:

- a. The exhaust pushrods (A, **Figure 52**) and are 10.800 in. (274.32 mm) long.
- b. The intake pushrods (B, **Figure 52**) are marked with a single brown band and are 10.746 in. (272.94 mm) long.
- c. Confirm pushrod length.

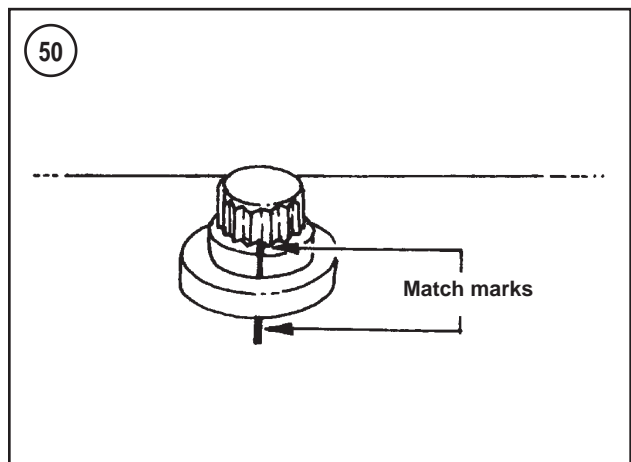
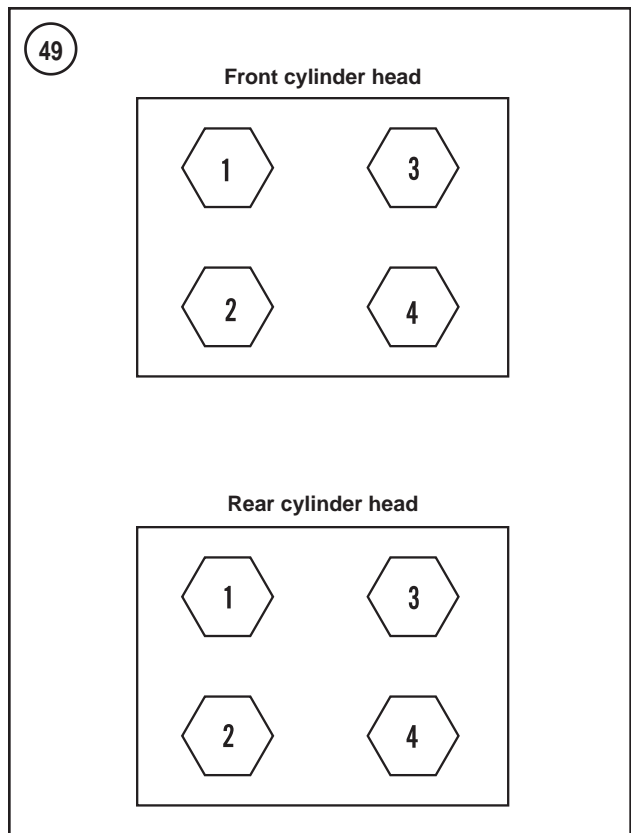

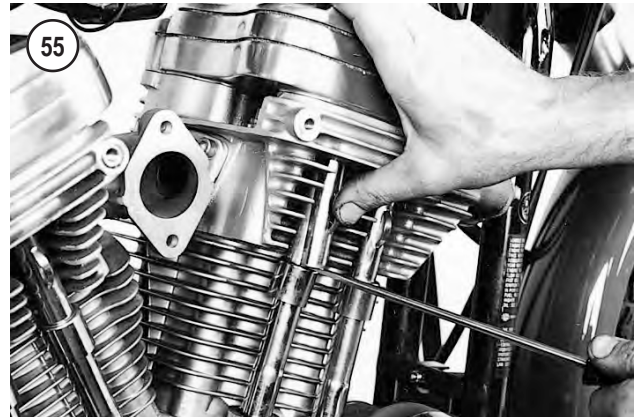
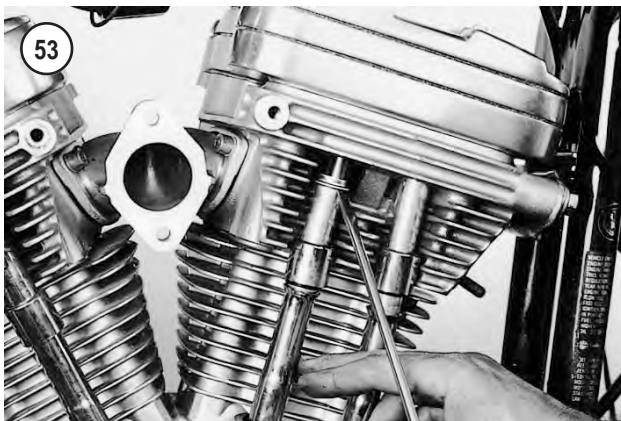
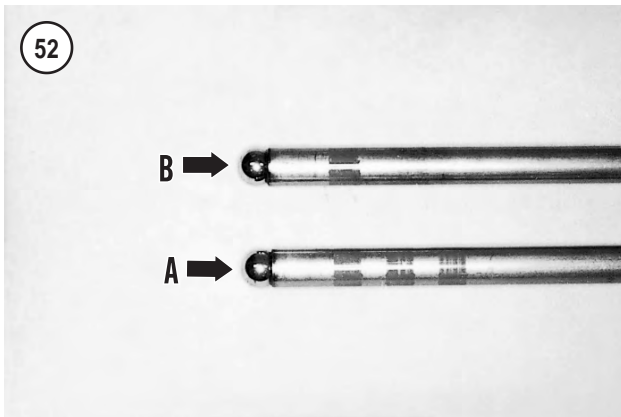
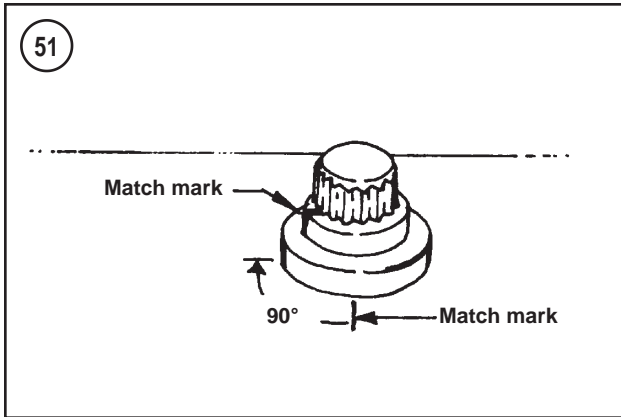

- d. Make sure that each pushrod is seated in the top of its respective tappet.
11. Install the rocker covers as described in this chapter.
12. Install the intake manifold as described in Chapter Ten or Chapter Eleven.
13. On 1986-1990 models, position the upper pushrod covers using the following procedure:
 - a. Push the upper pushrod cover up (**Figure 53**) and seat it in the cylinder head (**Figure 54**).
 - b. Position the spring cap retainer as shown in **Figure 55**. Place a screwdriver under the retainer and lift the screwdriver up slightly and slide the retainer into position.
14. Install the top center engine mount assembly (**Figure 56**) as follows:
 - a. Install the top center engine mount bolts and washers through the engine mount.
 - b. Place the shim, if used, onto the top center engine mount bolts as shown in **Figure 56**.

NOTE

Three different shim thicknesses are available: 0.030 in. (0.076 mm), 0.060 in. (1.52 mm) and 0.090 in. (2.27 mm). If the engine cases, cylinder heads, top center engine mount or frame were not replaced, the original thickness shim can be installed. If one of these major components was replaced, a different thickness shim may be required.

- c. Install the top center engine mount onto the engine. Insert the two engine mount bolts through the frame so that the shim does not fall off.
- d. Place the nut plate into position (**Figure 56**) and thread the engine mount bolts into the nut plate hand tight.
- e. Install the VOES.
- f. Tighten the engine bolts to 25-30 ft.-lb. (34-41 N•m).
- g. Tighten the frame bolts to 30-35 ft.-lb. (41-47 N•m).
15. Install the top front engine mount bracket (**Figure 57**) as follows:

56

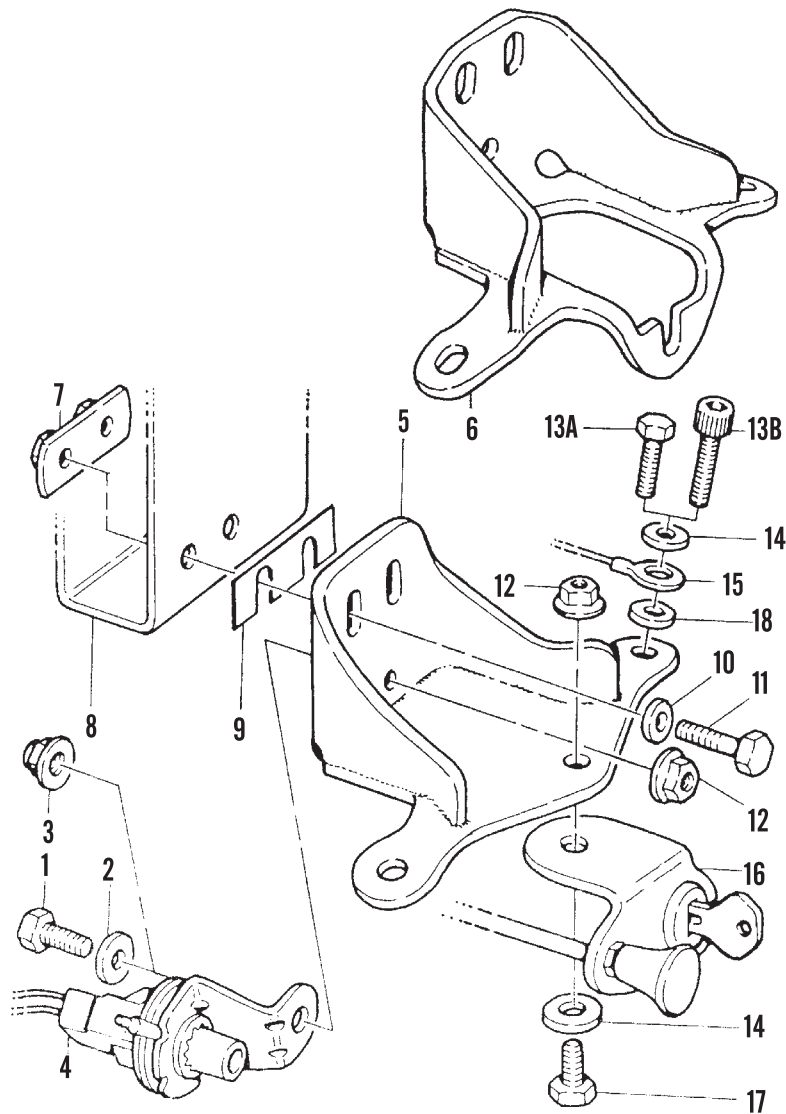
TOP CENTER ENGINE MOUNT

1. Bolt
2. Washer (1986-1991 models)
3. Locknut (1992-2003 models)
4. Vacuum-operated electric switch (all models except 1998-2003 1200S models)
5. Top center engine bracket (1986-1994 models)
6. Top center engine bracket (1995-2003 models)
7. Nut plate
8. Frame
9. Shim

10. Washer
11. Bolt
12. Locknut
- 13A. Bolt (1986-1991 models)
- 13B. Bolt (1992-2003 models)
14. Lockwasher (1986-1994 models)/ Washer (1995-2003 models)
15. VOES ground wire (1986-1993 models)
16. Ignition bracket (1986-1994 models)
17. Bolt
18. Washer (1986-1994 models)

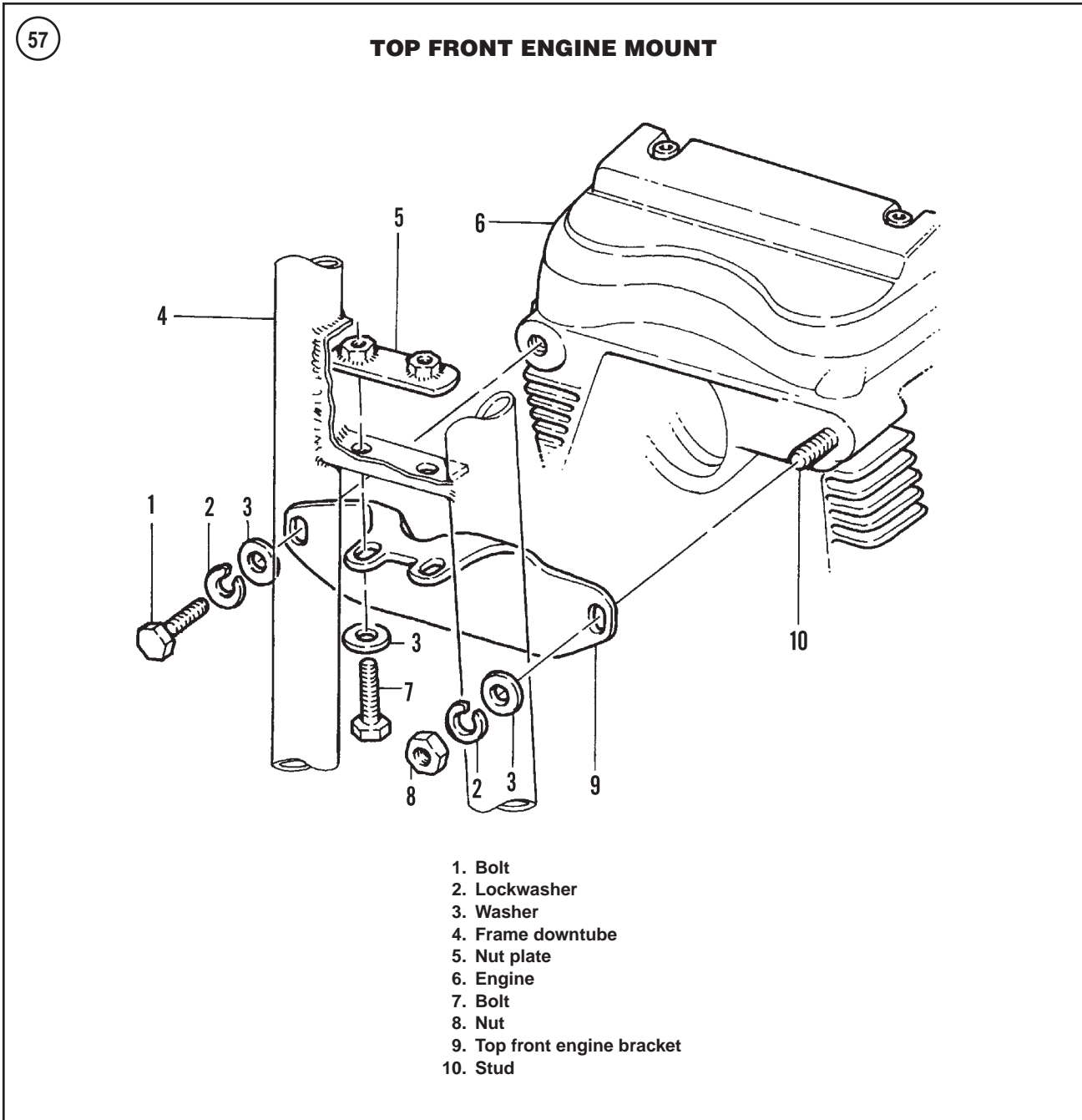

- a. Install the front upper mounting bracket and fasteners as shown in **Figure 57**. Tighten all of the bolts hand-tight only.
- b. Tighten the engine bolts to 25-30 ft.-lb. (34-41 N•m).
- c. Tighten the frame bolts to 30-35 ft.-lb. (41-47 N•m).

16. Install the carburetor and intake manifold as described in Chapter Ten or Chapter Eleven.

17. On all models except 1998-2003 1200S models, connect the VOES vacuum hose to the fitting on the carburetor (**Figure 58**) and connect the VOES electrical connector at the ignition module.

59

CYLINDER HEAD

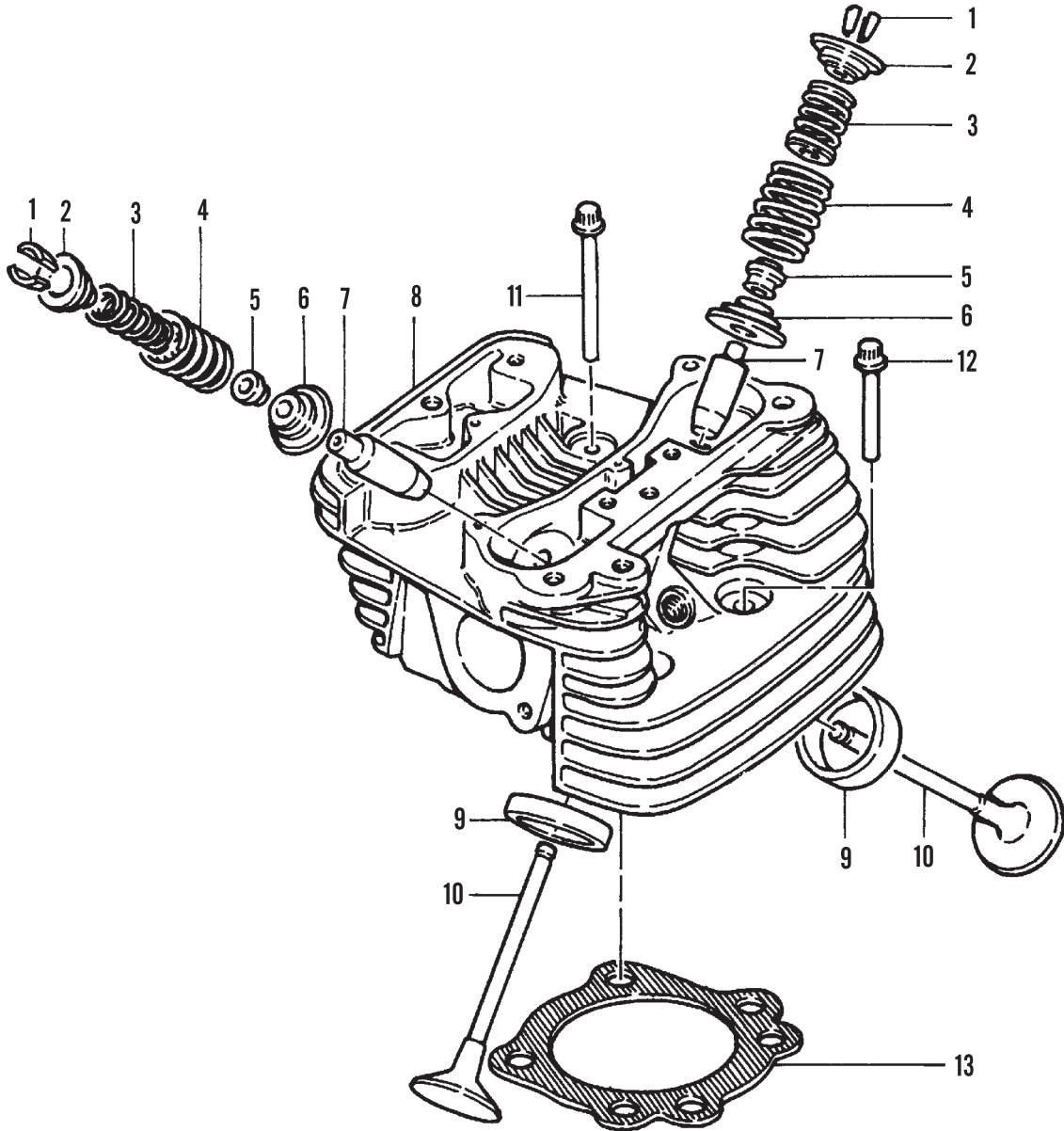

- 1. Valve keepers
- 2. Upper collars
- 3. Inner valve spring
- 4. Outer valve spring
- 5. Valve stem seal
- 6. Lower collar
- 7. Valve guide
- 8. Cylinder head
- 9. Valve seat
- 10. Valve
- 11. Bolt (long)
- 12. Bolt (short)
- 13. Head gasket

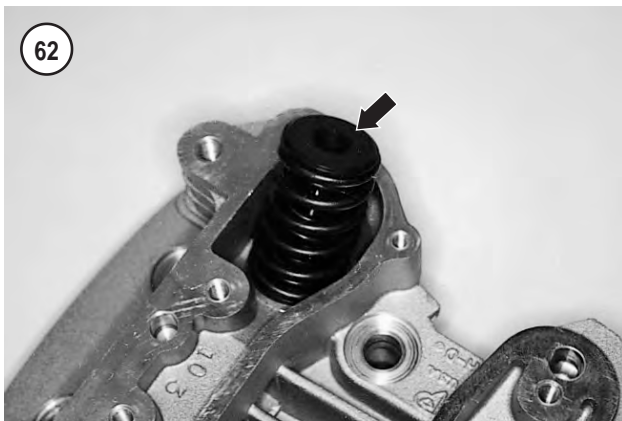
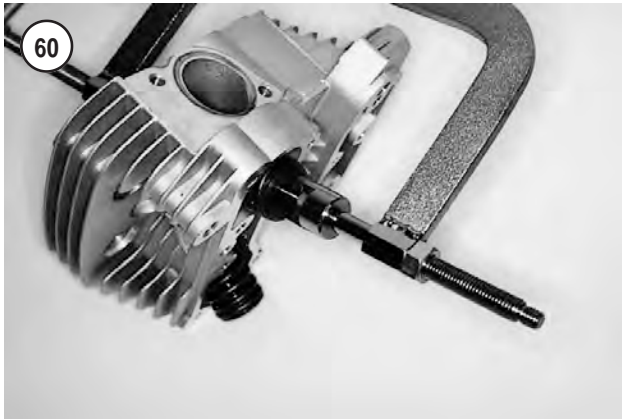

18. Install the choke knob, and on 1986-1994 models, the ignition switch bracket. Connect the ignition switch wires (Chapter Twelve).
19. Reinstall the ignition coil bracket and the throttle cable clip (where equipped).
20. Install the ignition coil as described in Chapter Twelve.
21. Install the horn as described in Chapter Twelve.
22. Install the spark plugs (Chapter Three).
23. Reconnect the spark plug wires.
24. Install the backplate and air filter assembly as described in Chapter Ten or Chapter Eleven.
25. Install the exhaust system as described in Chapter Ten or Chapter Eleven.
26. Install the fuel tank as described in Chapter Ten and Chapter Eleven.

4

VALVES AND VALVE COMPONENTS

Due to the number of special tools, it is generally more practical to remove the cylinder head and entrust valve service to a dealership or machine shop. The following procedures describe how to check for valve component wear and to determine what type of service is required.

Refer to **Figure 59**.

Valve Removal

CAUTION

All component parts of each valve assembly must be kept together. Do not mix with like components from other valves or excessive wear may result.

1. Remove the cylinder head(s) as described in this chapter.
2. Install a valve spring compressor over the valve retainer with other end of the tool placed against valve head (**Figure 60**).
3. Tighten the valve spring compressor until the split valve keepers separate. Remove the split keepers (**Figure 61**).
4. Loosen the valve spring compressor and remove from the head. Lift off the valve collar (**Figure 62**).
5. Remove the valve springs (**Figure 63**).

CAUTION

*Remove any burrs from the valve stem grooves (**Figure 64**) before removing the valve; otherwise, the valve guides will be damaged.*

6. Push the valve stem (**Figure 65**) down through the valve seal, then remove the valve.
7. Remove the lower valve collar (**Figure 66**) and seal assembly (**Figure 67**).
8. Repeat Steps 2-7 and remove the remaining valve.

Valve Inspection

Refer to **Table 2**. Replace components not within tolerance.

1. Clean the valves with a wire brush and solvent.
2. Inspect the contact surface of each valve (**Figure 68**) for burning. Minor roughness and pitting can be removed by lapping the valve as described in this section. Excessive unevenness to the contact surface is an indication that the valve is not serviceable. Replace the valve if damaged.
3. Inspect the valve stems (**Figure 65**) for wear.
4. Measure the valve stem outer diameter (**Figure 69**). Record the outer diameter for each valve.
5. To clean the valve guides, perform the following:
 - a. Lightly hone the valve guide using valve guide hone (part No. HD-34723). Lubricate the hone with honing oil. Do not use motor oil. Drive the hone with an electric drill (500-1200 rpm).
 - b. Soak the head in hot, soapy water and clean the guides using a valve guide brush (part No. HD-34751).
 - c. Repeat for each valve guide.
 - d. Rinse the head in cold water and blow dry.
6. Measure each valve guide (A, **Figure 70**) at top, center and bottom using a small hole gauge. Record the inner diameter for each valve guide.
7. Subtract the measurement made in Step 4 from the measurement made in Step 6. The difference is the valve guide-to-valve stem clearance. Replace any guide and valve not within tolerance.

NOTE

The manufacturer does not list specific valve guide inner diameter and valve stem outer diameter measurements. Service wear is determined by measuring the valve stem clearance measurement.

8. Measure the valve spring free length (**Figure 71**). Replace the spring if it has sagged to the service limit.
9. Measure valve spring compression using a compression tool (**Figure 72**) and compare to specifications in **Table 3**. Replace weak or damaged springs.
10. If any one valve has a spring that is worn or damaged as determined in Steps 8-9, replace the valve springs as a set.
11. Check the valve spring retainers and split keepers. Replace worn or damaged parts as required.
12. Inspect valve seats (B, **Figure 70**). If worn or burned, they must be reconditioned. Seats and valves in near-perfect condition can be reconditioned by lapping with fine carborundum paste.

Valve Guide Replacement

When guides are worn so there is excessive stem-to-guide clearance or valve tipping, they must be replaced. Replace all of the guides at the same time.

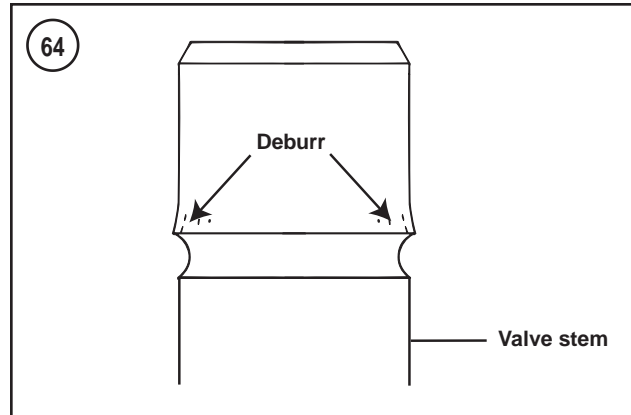

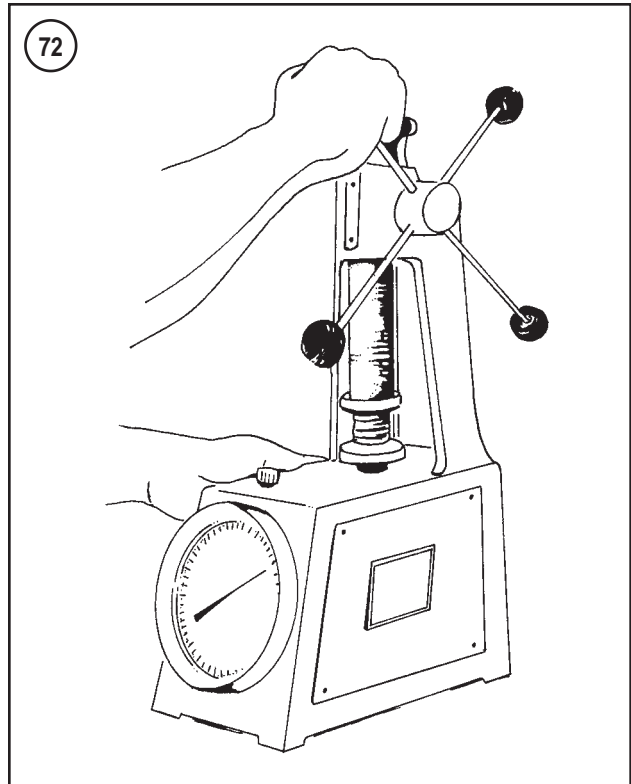
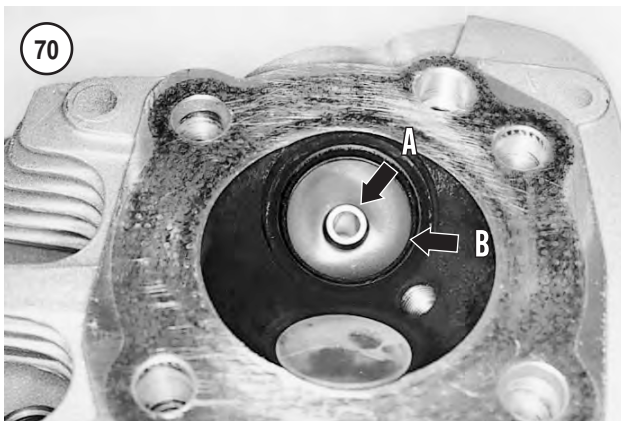
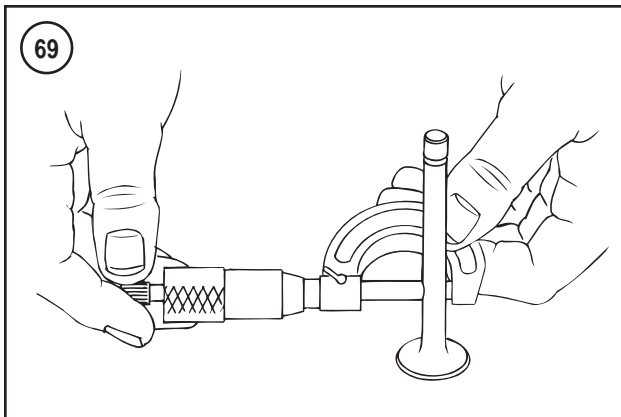
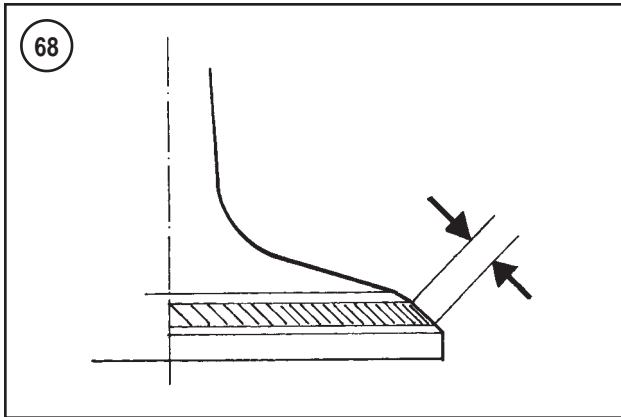

1. Make sure to have the following tools available before starting this procedure:

- a. Driver handle and remover (part No. HD-34740 or equivalent). By itself, this tool is used to remove the valve guides. This tool, along with the valve guide installation tool, is used to install the valve guides.
- b. Valve guide installation tool (part No. HD-34731A or equivalent). Part of HD-34731A is a sleeve that indicates when correct valve guide installation position is achieved. If this specific tool is not used, measuring valve guide position before removal is necessary so the new guide can be installed in the same position
- c. Valve guide reamer (part No. HD-39932, HD-39932-CAR or equivalent). This tool is used to ream the valve guides after they have been installed in the cylinder head.
- d. Valve guide hone (part No. HD-34723 or equivalent). This tool is used to hone the valve guides after reaming them to size.
- e. Valve guide brush (part No. HD-34751 or equivalent). This tool is used to clean the valve guides after honing them.
- f. Honing oil. Only honing oil should be used when honing the valve guides.

2. Place the cylinder head on a wooden surface so that the combustion chamber faces down.

3. Shoulderless valve guides are used. Before removing the guides, note and record the shape of the guide that projects into the combustion chamber. Measure the distance from the top of the guide to the cylinder head surface as

shown in **Figure 73**. Record this distance for each valve guide so that the guides can be installed to the same dimension.

4. The guides can be either driven or pressed out. Remove the valve guides as follows:

CAUTION

The correct size valve guide removal tool must be used when removing the valve guides; otherwise, the tool may mushroom the end of the guide. A mushroomed guide will widen the guide bore in the cylinder head as it passes through it.

- a. Support the cylinder head so the combustion chamber faces down. If driving out the guides, place the cylinder head on a piece of wood. If you are pressing the guides out, support the cylinder head in a press so that the valve guide is perpendicular to the press table.
 - b. Insert the driver handle and remover in the top of the valve guide.
 - c. Press or drive out the valve guide through the combustion chamber.
 - d. Repeat to remove the remaining valve guides.
5. Clean the valve guide bores in the cylinder head.
6. Because the valve guides are a press fit in the cylinder head, the new guide's outer diameter must be sized with the valve guide bore in the cylinder head. This is because the guide bore in the cylinder is sometimes enlarged during guide removal. Determine valve guide sizes as follows:
- a. Measure the valve guide bore inner diameter in the cylinder head. Record the bore inner diameter.
 - b. The new valve guide outer diameter must be 0.0020-0.0033 in. (0.051-0.083 mm) larger than the guide bore in the cylinder head. When purchasing new valve guides, measure the new guide outer diameter with a micrometer. If the new guide outer diameter is not within these specifications, oversize valve guide(s) will be required.
7. Apply a thin coating of molybde or white grease to the valve guide outer diameter prior to installation.

CAUTION

When installing oversize valve guides, be sure to match each guide to its respective bore in the cylinder head.

8. Install the new valve guide using the valve guide installation tool. Make sure to press or drive the guide into the cylinder head to the depth recorded prior to removing the guide. If using the HD-34731A installation tool, press or drive the guide into the head until the tool bottoms on the cylinder head surface. Verify the installed height after removing the tools.
9. Because replacement valve guides are sold with their inner diameter smaller than the valve stem, each guide must be reamed to fit the valve stem. Use the valve guide reamer.

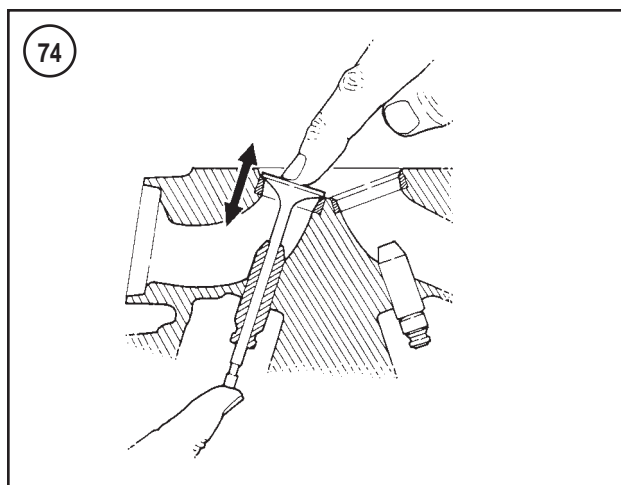
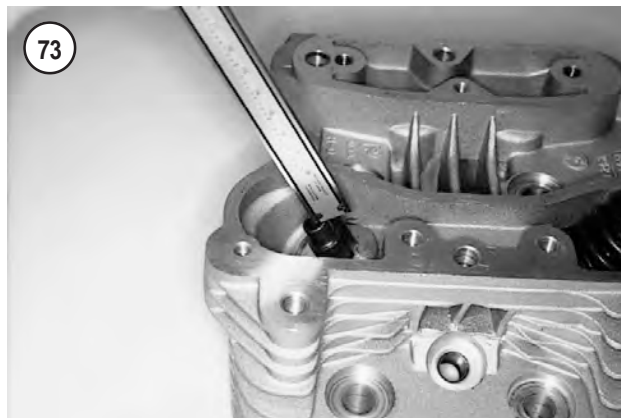

Use honing oil on the reamer when reaming the guide. Ream the guide to within 0.0001-0.0005 in. (0.013-0.025 mm) of the finished valve guide inner diameter. Refer to **Table 2** for valve stem clearances and service limits.

CAUTION

When honing the valve guides, keep the valve stem clearance specifications. Excessive honing may produce out-of-spec valve stem clearance.

10. Hone the valve guide using the valve guide hone. Lubricate the hone with honing oil. Do not use motor oil. Drive the hone with an electric drill at speeds between 500-1200 rpm. Hone the guide until the valve stem clearance specified in **Table 2** is obtained and with a crosshatch pattern of 60°.
11. Repeat for each valve guide.
12. Soak the cylinder head in a container filled with hot, soapy water. Clean the valve guides using the valve guide brush. Do not use a steel brush. Do not use cleaning solvent, kerosene or gasoline, as these chemicals will not remove all of the abrasive and minute particles produced during the honing operation. Repeat this step until the valve guides have been thoroughly cleaned. Rinse the cyl-

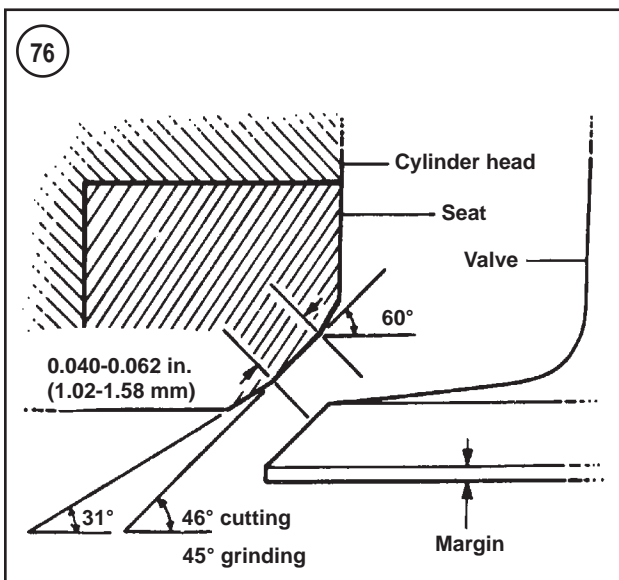
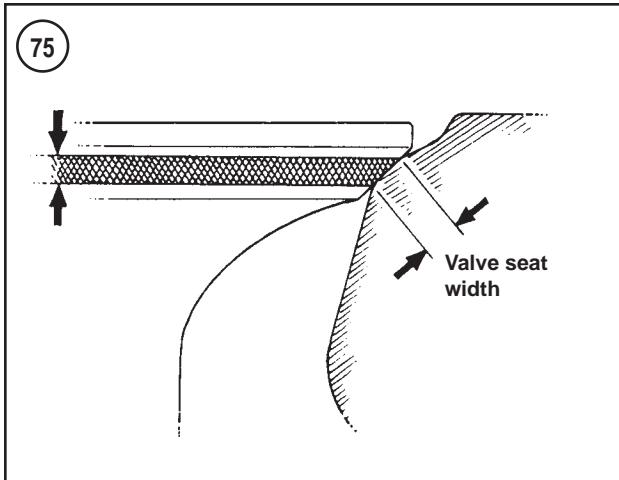

inder head and valve guides in clear, cold water and dry with compressed air.

13. After cleaning and drying the valve guides, apply clean engine oil to the guides to prevent rust.

14. Reface the valve seats to make them concentric with the new valve guides. Refer to the *Valve Seat Reconditioning* section in this section.

Valve Seat Inspection

CAUTION

Because of the close operating tolerances within the valve assembly, the valve stem and guide must be within tolerance; otherwise, the inspection results will be inaccurate.

1. Clean the valves of all carbon, then clean the valve as described in the *Valve Inspection* in this section.
2. The most accurate method of checking the valve seat width and position is to use machinist's dye. To check the valve seat with machinist's dye, perform the following:

NOTE

Install the valves in their original locations when performing the following.

- a. Thoroughly clean the valve face and valve seat with contact cleaner.
 - b. Apply a thin layer of machinist's dye evenly on the valve face.
 - c. Insert the valve into its guide.
 - d. Support the valve by hand and tap the valve up and down in the cylinder head (**Figure 74**). Do not rotate the valve or the reading will be false.
 - e. Remove the valve and examine the impression left by the machinist's dye. If the impression left in the dye (on the valve or in the cylinder head) is not even and continuous and the valve seat width (**Figure 75**) is not even and continuous within the specification (**Table 2**), recondition the cylinder head valve seat as described in this section.
3. Examine the valve seat in the cylinder head (**Figure 75**). It should be smooth and even with a polished seating surface.
 4. If the valve seat is okay, install the valve as described in this chapter.
 5. If the valve seat is not correct, recondition the valve seat as described in this section.

Valve Seat Reconditioning

A valve cutter set (part No. HD- 35758-B or equivalent) is required to recondition the valve seats. If these tools, or their equivalents, are not available, refer the work to a dealership.

While the valve seats for both the intake and exhaust valves are machined to the same angles, different cutter sizes are required.

NOTE

The manufacturer recommends cutting the valve seat to restore it to factory specifications. Follow the manufacturer's instructions when using valve facing equipment.

The valve seat angles are shown in **Figure 76**.

1. Clean the valve guides as described under *Valve Inspection* in this section.
2. Rotate and insert the solid pilot into the valve guide. Make sure the pilot is correctly seated.

CAUTION

Valve seat accuracy will depend on a correctly sized and installed pilot.

3. Using the 46° cutter tool, descale and clean the valve seat with one or two turns.

CAUTION

*Measure the valve seat contact in the cylinder head (**Figure 75**) after each cut to make sure*

the contact area is correct and to avoid removing too much material. Excessive cutting will sink the valve too far into the cylinder head, requiring replacement of the valve seat.

4. If the seat is still pitted or burned, turn the 46° cutter additional turns until the surface is clean.
5. Remove the pilot from the valve guide.
6. Measure the valve seat (**Figure 75** and **Figure 76**). Record the measurement to use as a reference point when performing the following.
7. Install the 31° cutter onto the solid pilot and lightly cut the seat to remove 1/4 of the existing valve seat.
8. Install the 60° cutter onto the solid pilot and lightly cut the seat to remove the lower 1/4 of the existing valve seat.
9. Measure the valve seat. Then fit the 46° cutter onto the solid pilot and cut the valve seat to the specified seat width listed in **Table 2**.
10. Remove the solid pilot from the cylinder head.
11. Inspect the valve seat-to-valve face impression as follows:
 - a. Clean the valve seat with contact cleaner.
 - b. Apply a thin layer of machinist's dye evenly on the valve face.
 - c. Insert the valve into its guide.
 - d. Support the valve by hand and tap the valve up and down in the cylinder head (**Figure 74**). Do not rotate the valve or the reading will be false.
 - e. Remove the valve and examine the impression left by the machinist's dye.
 - f. Measure the valve seat width (**Figure 75** and **Figure 76**). Refer to **Table 2** for the correct seat width.
 - g. The valve contact area should be approximately in the center of the valve seat area.
12. If the contact area is too high on the valve, or if it is too wide, use the 31° cutter and remove a portion of the top area of the valve seat material to lower or narrow the contact area.
13. If the contact area is too low on the valve, or if it is too wide, use the 60° cutter and remove a portion of the lower area to raise and widen the contact area.
14. After the desired valve seat position and angle is obtained, use the 46° cutter tool and very lightly clean off any burrs that may have been caused by the previous cuts.
15. Clean the valve seat and valve face. Insert the valve into the valve guide. With the valve seated in the head, measure the valve stem protrusion (the distance from the end of the valve stem to the valve pocket in the cylinder head.) If valve stem protrusion exceeds the service limit in **Table 2**, the valve seat or the cylinder head must be replaced.
16. Repeat Steps 1-15 for all remaining valve seats.
17. Thoroughly clean the cylinder head and all valve components in solvent, then clean with detergent and hot water and finish with a final rinsing in cold water. Dry with compressed air. Then apply a light coat of engine oil to all non-aluminum metal surfaces to prevent rust.

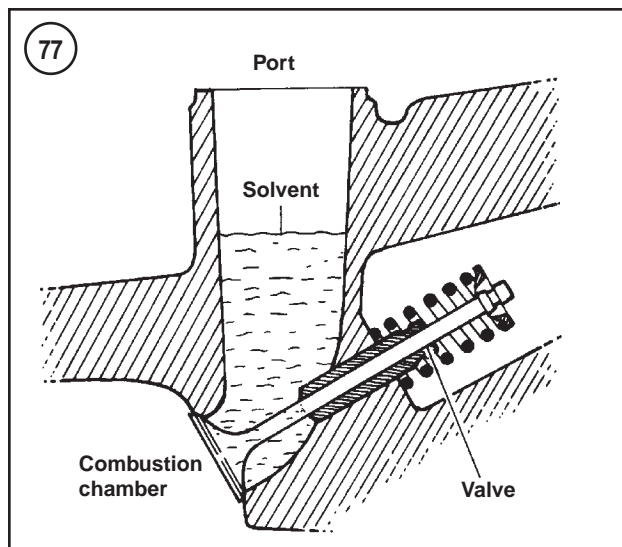

Valve Lapping

Valve lapping restores the valve seal without machining if the amount of wear or distortion is not excessive.

1. Apply a light coating of fine grade valve lapping compound on seating surface of the valve.
2. Insert the valve into the head.
3. Wet the suction cup of the lapping stick and place it onto the head of the valve. Lap the valve to the seat by spinning tool between your hands while lifting and moving the valve around the seat 1/4 turn at a time.
4. Wipe off the valve and seat frequently to check progress of lapping. Lap only enough to achieve a precise seating ring around valve head.
5. Closely examine the valve seat in the cylinder head. It should be smooth and even with a smooth, polished seating ring.
6. Thoroughly clean the valves and cylinder head in solvent to remove all grinding compound. Any compound left on the valves or the cylinder head will end up in the engine and cause premature and rapid engine wear.
7. After the lapping has been completed and the valve assemblies have been reinstalled into the head, the valve seal should be tested. Check the seal of each valve by pouring solvent into each of the intake and exhaust ports (**Figure 77**). There should be no leaks past the seat. If leaks occur, the combustion chamber will appear wet. If fluid leaks past any of the seats, disassemble that valve assembly and repeat the lapping procedure until there are no leaks.

Valve Seat Replacement

Due to the number of special tools needed to replace the valve seats, it is generally more practical to refer this work to a dealership.

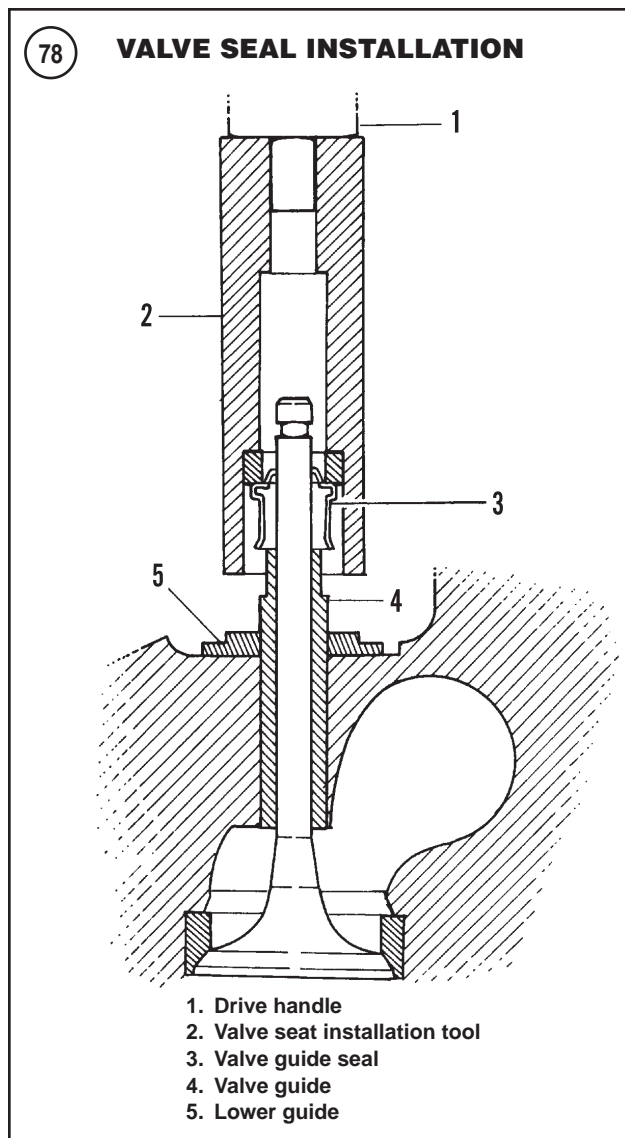

Valve Installation

CAUTION

The cylinder heads, valve seats and valves must be thoroughly cleaned before reassembling the cylinder head. Any lapping compound left on the cylinder head or valves will result in excessive engine wear.

1. Coat the valve stem with clean engine oil and insert the valve into its valve guide in the cylinder head.
2. Install the lower collar (**Figure 66**) so that the flat side faces down.
3. Install new valve guide seals as follows:
 - a. Place a protective cover, such as cling wrap, over the end of the valve stem making sure to cover the valve keeper groove on valve stem. The protective cover prevents the valve stem keeper groove from tearing the valve stem seal.



4

- b. Wipe the protective cover with clean engine oil and place a new valve guide seal on the cover.
 - c. Tap the seal into place using a valve seal installation tool and driver handle (**Figure 78**). The oil seal is installed when the installation tool bottoms on the lower collar. If the tools are not available, use a socket and hammer and tap the seal into place so it bottoms against the lower collar (**Figure 66**).
 - d. If a seal must be removed after installation, discard it and install a new seal.
4. Install the valve springs (**Figure 63**). Then install the upper valve spring collar (**Figure 62**).
 5. Push down on the upper valve spring collar with the valve spring compressor (**Figure 60**) and install the valve keepers (**Figure 61**). After releasing tension from the compressor, lightly tap the upper retainer with a plastic hammer to make sure the keepers (**Figure 79**) are seated.
 6. Repeat to install the remaining valve guide seals and valves.

PUSHRODS AND COVERS

CAUTION

Make sure to mark the location of each pushrod before removing it. The pushrods must be installed in their original position.

Removal/Installation

NOTE

The carburetor was removed for clarity in the following figures. It is not necessary to remove the carburetor.

1986-1990 models

1. Remove the air filter backplate as described in Chapter Ten or Chapter Eleven.
2. Using a screwdriver, pry the spring cap retainer out of the pushrod assembly (**Figure 80**).
3. Remove the rocker covers as described in this chapter for access to the pushrods (**Figure 81**).
4. Mark the pushrods so they can be installed in their original positions, then remove the pushrods (**Figure 81**).

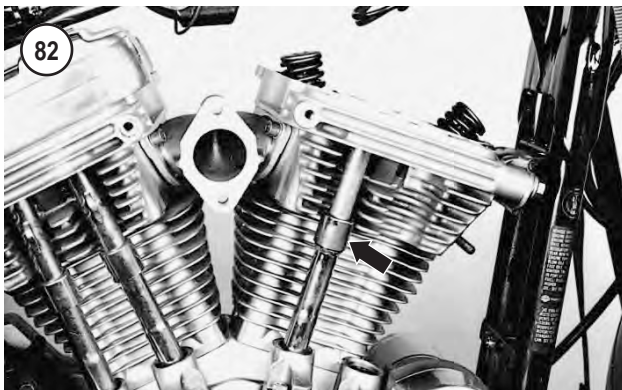
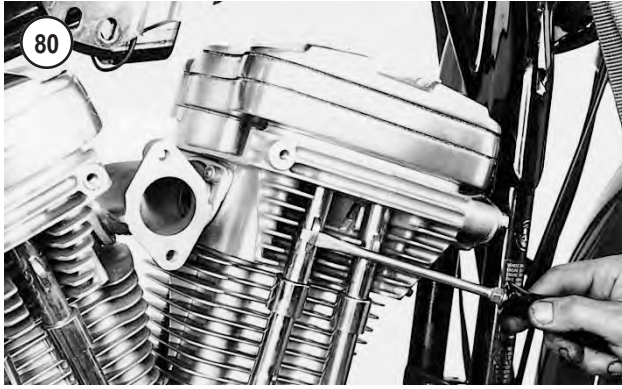

5. Remove the pushrod cover assembly (**Figure 82**).
6. Discard the upper and lower O-rings (**Figure 83**).
7. To disassemble and reassemble the cover assembly, proceed as follows:
 - a. Remove the lower pushrod cover (**Figure 84**).
 - b. Remove the middle O-ring (**Figure 85**).
 - c. Remove the washer (**Figure 86**).
 - d. Remove the spring (**Figure 87**).
 - e. Remove the cover spring cap (**Figure 88**).
 - f. Clean all the parts. Discard the O-rings. Inspect the spring and replace if necessary.
 - g. Reassemble the cover assembly by reversing the preceding steps.
8. Install the pushrod cover assembly (**Figure 82**) using new O-rings at the lower and upper ends as described in *Cylinder Head* in this chapter.

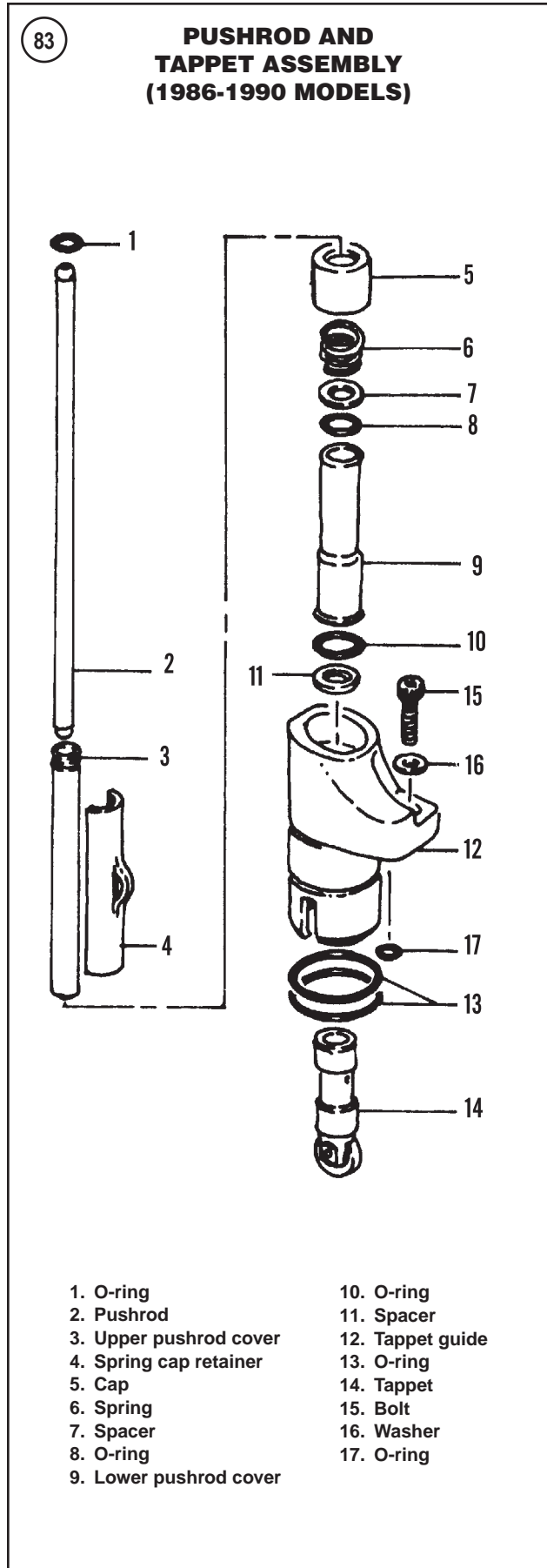

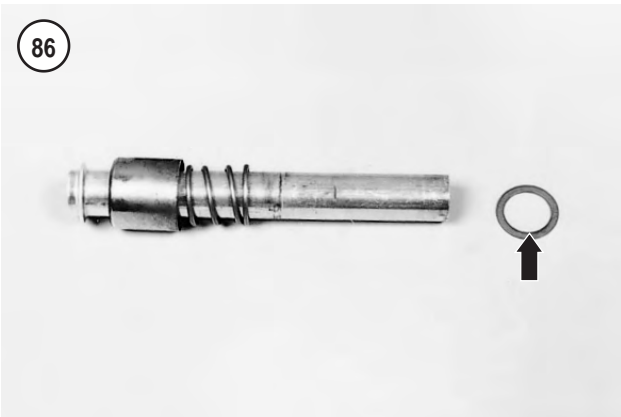
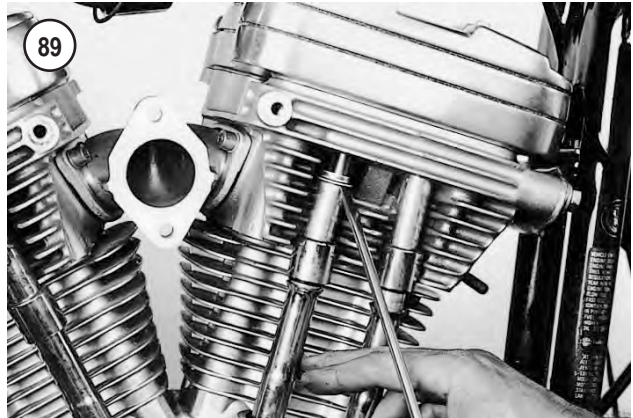
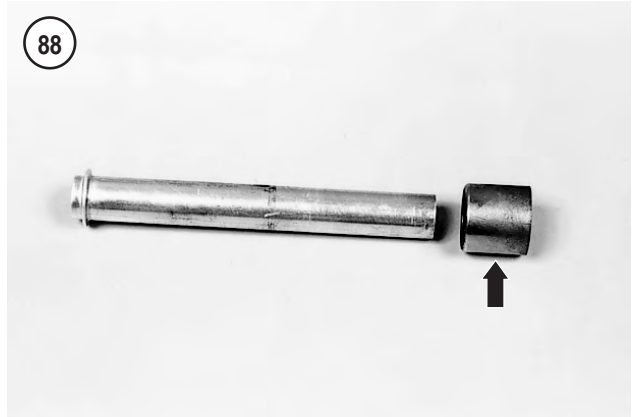
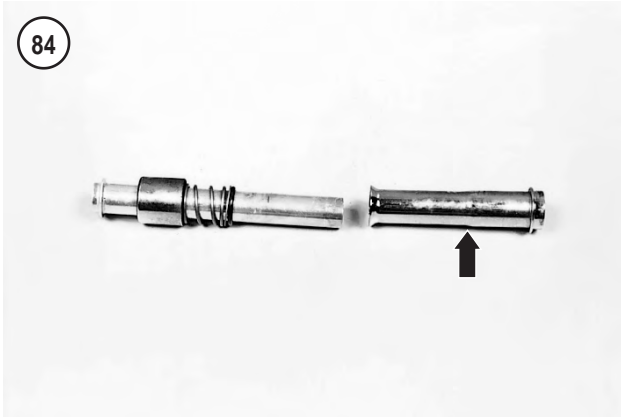

9. Install the pushrods and rocker cover as described in this chapter.

10. Push the upper pushrod cover up (**Figure 89**) and seat it in the cylinder head (**Figure 90**).

11. Position the spring cap retainer as shown in **Figure 91**. Place a screwdriver under the retainer and lift the screwdriver up slightly and slide the retainer into position.

12. Install the air filter backplate as described in Chapter Ten or Chapter Eleven.

1991-2003 models

1. Remove the air filter backplate as described in Chapter Eleven.

2. For access to the pushrods (**Figure 92**), remove the rocker covers as described in this chapter.
3. Mark the pushrods so they can be installed in their original positions, then remove the pushrods (**Figure 92**).
4. Loosen the Allen bolt securing the retainer plate (**Figure 93**), then remove the pushrod cover assembly (**Figure 94**).
5. Inspect the pushrod cover components (**Figure 95**). Discard the seal and O-ring.
6. Install the pushrod cover by reversing the removal steps while noting the following:
 - a. Install a new seal and O-ring.
 - b. Insert the upper end of the cover tube into the cylinder head first, then align the lower end with the tappet hole in the crankcase.
 - c. Align the index hole in the retainer plate with the locating pin in the crankcase.
 - d. Tighten the Allen bolt to 15-18 ft.-lb. (20-24 N•m).
7. Install the air filter backplate as described in Chapter Eleven.

Inspection

1. Clean the pushrods in solvent and dry using compressed air.
2. Inspect the pushrods (**Figure 96**) for:
 - a. Bending.
 - b. Cracks.
 - c. Excessively worn or damaged ball ends.
- 3A. On 1986-1990 models, if replacement is required, a new pushrod may be selected by matching the identifying color code bands on the pushrod.

CAUTION

If a valve train component has been replaced on 1986-1990 models, or if the cylinder head, valves and seats have been reconditioned or replaced, the length of each pushrod must be checked and adjusted. This procedure should be referred to a dealership as special tools are required. In addition, the pushrods must be installed in their original positions by following the marks made during disassembly. If the pushrods were not marked, the length must be checked by a dealership.

- 3B. On 1991-2003 models, if replacement is required note that the pushrods are different lengths and may be identified as follows:
 - a. The exhaust pushrods are marked with three pink bands (A, **Figure 97**) and are 10.800 in. (274.32 mm) long.
 - b. The intake pushrods (B, **Figure 97**) are marked with a single brown band and are 10.746 in. (272.94 mm) long.
 - c. Confirm pushrod length.

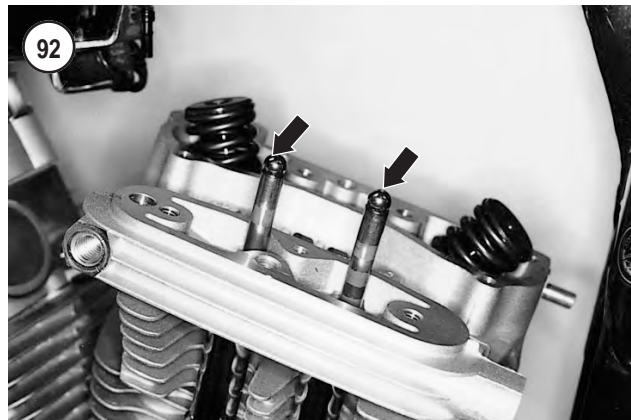
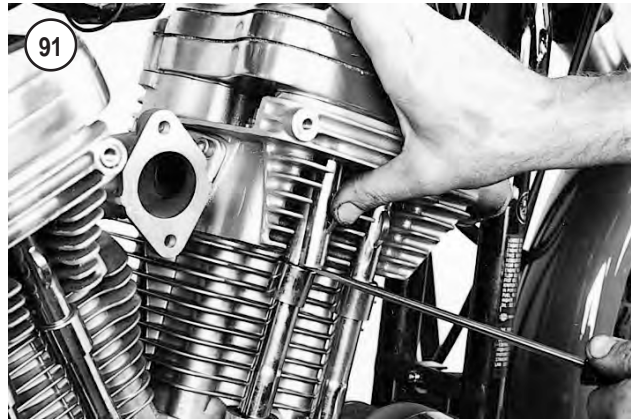

95

PUSHROD/TAPPET ASSEMBLY (1991-2003 MODELS)

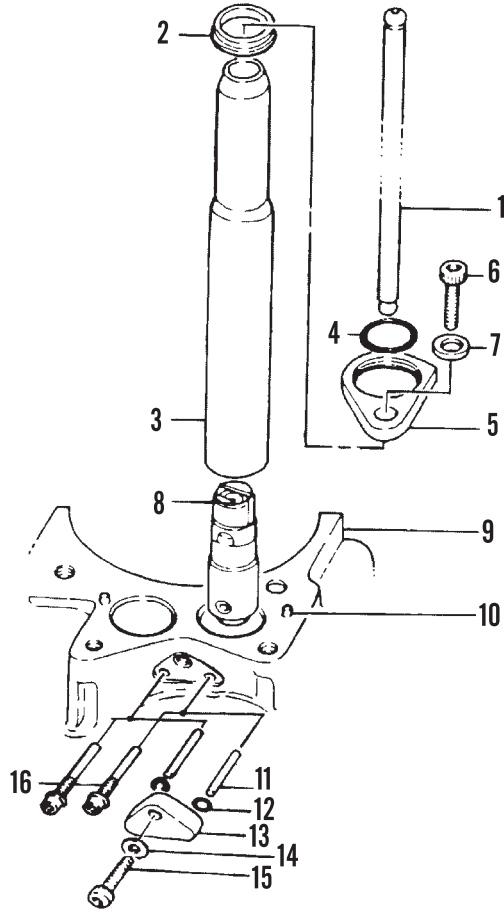

- 1. Pushrod
- 2. Seal
- 3. Cover
- 4. O-ring
- 5. Retainer plate
- 6. Bolt
- 7. Washer
- 8. Tappet
- 9. Crankcase
- 10. Locating pin
- 11. Pin (1991-1999 models)
- 12. O-ring (1991-1999 models)
- 13. Plate (1991-1999 models)
- 14. Washer (1991-1999 models)
- 15. Allen bolt (1991-1999 models)
- 16. Antirotation bolt (2000-2003 models)

96

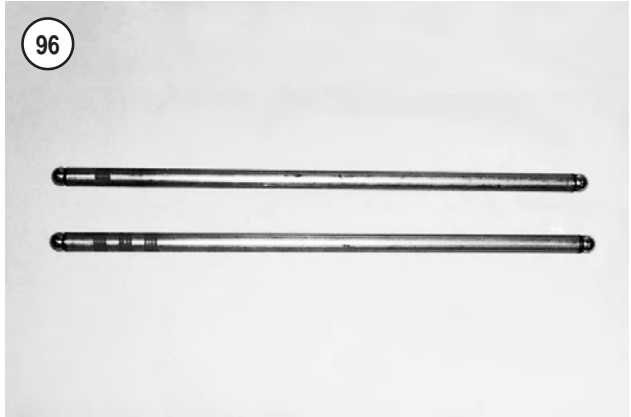

4

97

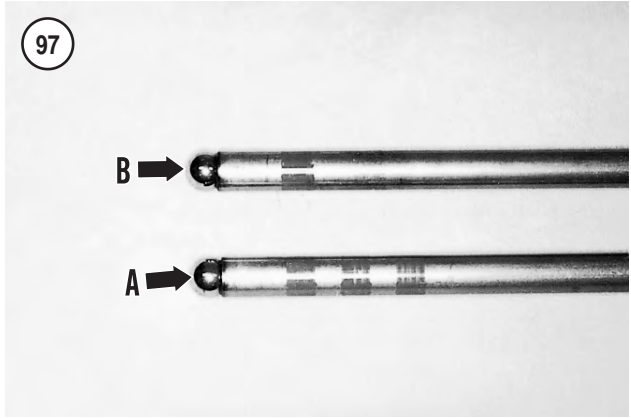

CYLINDER

Both cylinders can be removed with the engine mounted in the frame.

Removal

Refer to **Figure 98**.

1. Remove all dirt and debris from both cylinders. Mark the cylinder to ensure it is installed in its original position.
2. Remove the cylinder head as described in this chapter.
3. Remove the O-rings around the dowel pins (**Figure 99**). If necessary, also remove the dowel pins.
4. Turn the engine over until the piston is at bottom dead center (BDC).
5. Loosen the cylinder by tapping around the perimeter with a rubber or plastic mallet.
6. Pull the cylinder straight up and off the piston and cylinder studs.
7. Stuff clean shop rags into the crankcase opening (A, **Figure 100**) to prevent objects from falling into the crankcase.
8. Install a hose around each stud (B, **Figure 100**) to protect the piston and studs from damage.
9. Install a piston holding tool (C, **Figure 100**) to stabilize the piston. The tool may be constructed from wood as shown in **Figure 101**.

98

PISTON AND CYLINDER

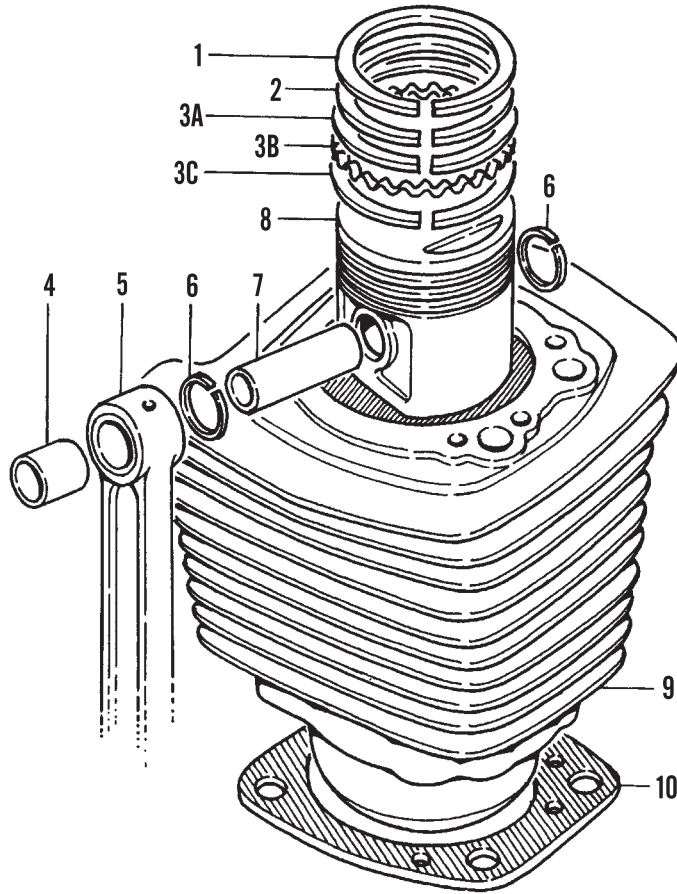

- | | |
|-------------------------------|-------------------|
| 1. Top compressionn ring | 5. Connecting rod |
| 2. Second compression ring | 6. Retaining ring |
| 3A. Oil control ring | 7. Piston pin |
| 3B. Oil control expander ring | 8. Piston |
| 3C. Lower oil ring | 9. Cylinder |
| 4. Bushing | 10. Base gasket |

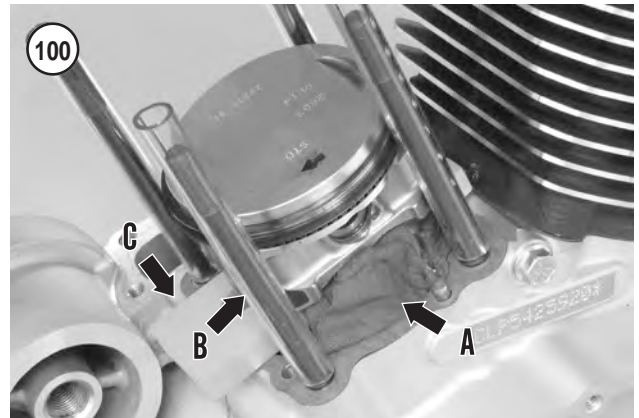

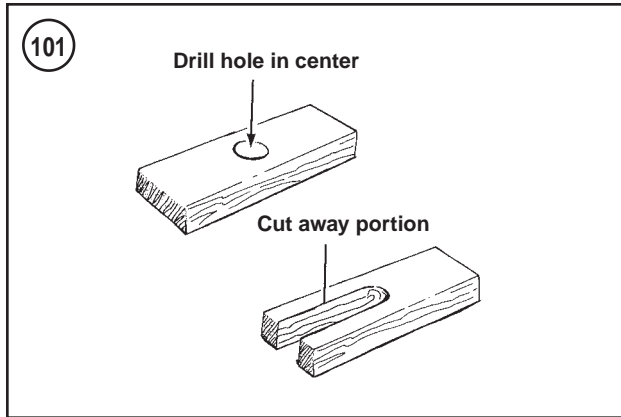

CAUTION
While the cylinder is removed, use care when working around the cylinder studs to avoid bending or damaging them. A bend could cause a stud failure later during engine operation.

10. Remove the pistons and rings as described in this chapter.
11. Repeat Steps 1-10 for the remaining cylinder.

Inspection

To obtain an accurate cylinder bore measurement, the cylinder must be secured between torque plates. Torque plates are available from several sources. This arrangement simulates the distortion imparted on a cylinder when it is clamped down by the cylinder head and the cylinder bolts are tightened to the specified torque. Measurements made without the engine torque plate can vary by 0.001 in. (0.025 mm). If you do not have access to the torque plates, refer service to a dealership.

1. Remove all gasket residue from both cylinder gasket surfaces.
2. Thoroughly clean the cylinder with solvent and dry with compressed air.
3. Lightly coat the cylinder bore with clean engine oil to prevent rust.
4. Check the top (**Figure 102**) and bottom cylinder block gasket surfaces with a straightedge and feeler gauge. Replace the cylinder and piston if the following warp limits are exceeded:
 - a. Top cylinder surface: 0.006 in. (0.152 mm).
 - b. Bottom cylinder surface: 0.008 in. (0.203 mm).
5. Check the cylinder walls (**Figure 103**) for scuffing, scratches or other damage.
6. Install the torque plates onto the cylinder (**Figure 104**) following the manufacturer's instruction.
7. Measure the cylinder bore at the points shown in **Figure 105**. Initial measurement should be made at a distance of 0.500 in. (12.7 mm) below the top of the cylinder. The 0.500 in. (12.7 mm) depth represents the start of the ring path area; do not take readings that are out of the ring path area.
8. Measure in two axes—in line with the piston pin and at 90° to the pin. If the taper or out-of-round is greater than specifications (**Table 2**), rebore the cylinders to the next oversize and install new pistons and rings. Rebore both cylinders even though only one may be worn.
9. Have a dealer or machine shop confirm all cylinder measurements before ordering replacement parts.

CAUTION
Hot soapy water is the only solution that will completely clean the cylinder walls. Solvent and kerosene cannot wash fine grit out of the cylinder crevices. Residual abrasive grit in

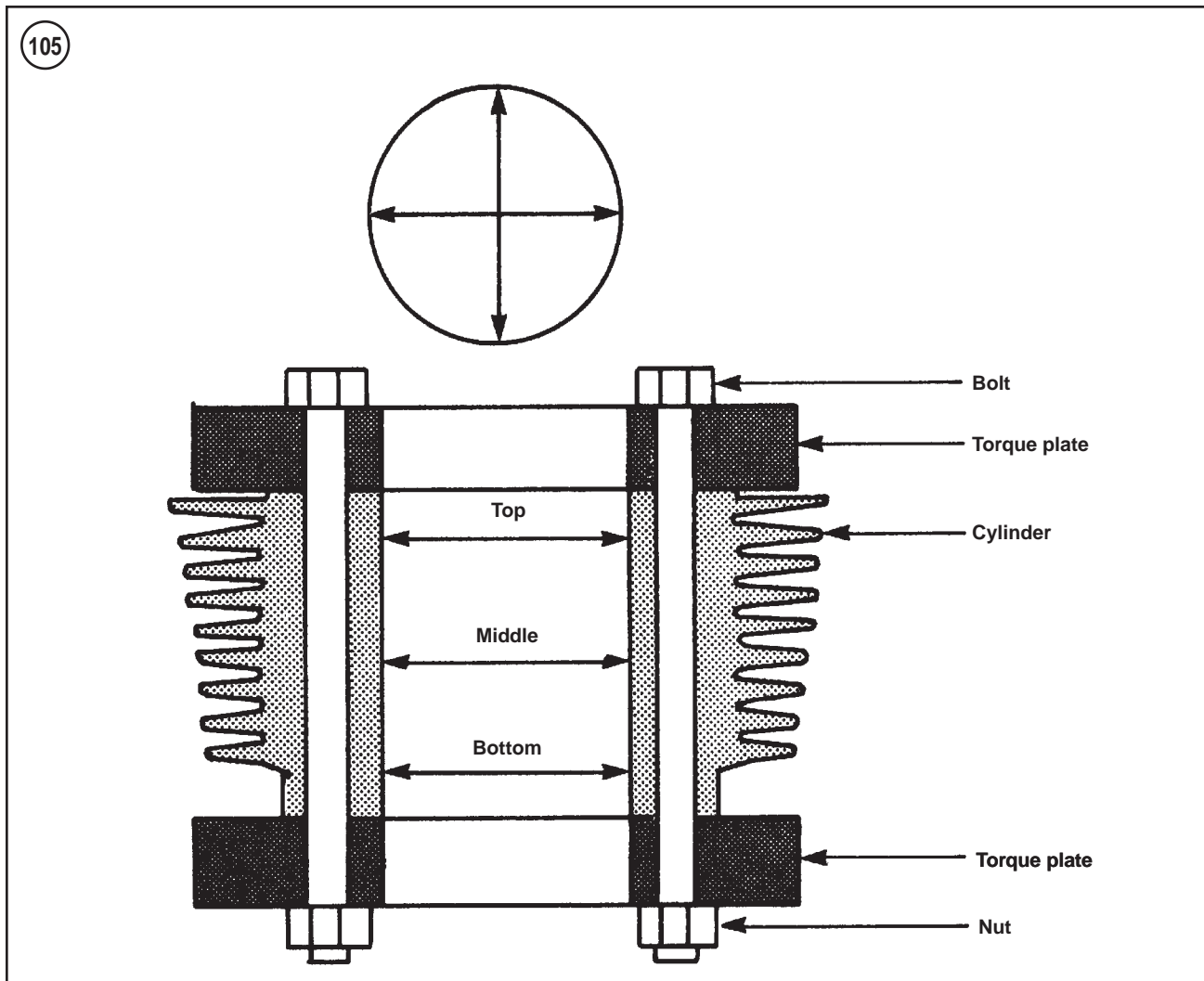

the cylinder wall will cause premature engine wear.

10. After the cylinders have been serviced, wash each cylinder in hot, soapy water. This is the only way to clean the cylinder walls of the fine grit material left from the boring or honing job. After washing the cylinder bore, run a clean white cloth through it. If the cloth shows traces of grit or oil, the cylinder is not clean enough. Repeat until the cloth comes out clean. When the cylinder wall is clean, dry with compressed air and then lubricate with clean engine oil to prevent the cylinder wall from rusting. Repeat for the other cylinder.

Studs and bolts

The cylinder studs and cylinder head bolts must be in good condition and properly cleaned prior to installing the cylinders and cylinder heads.

1. Examine the cylinder head bolts (**Figure 106**) for head or thread damage. Replace if necessary.

2. Examine the cylinder studs for bending, looseness or damage. Replace loose or damaged studs as described in the *Cylinder Studs* in Chapter Five. If the studs are in good condition, perform Step 3.

CAUTION

The cylinder studs, cylinder head bolts and washers are made of hardened material. Do not substitute these items with a part made of a lower grade material.

3. Cover the crankcase openings with shop rags to prevent debris from falling into the engine.

4. Remove all carbon residue from the cylinder studs and cylinder head bolts as follows:

- a. Apply solvent to the cylinder stud and mating cylinder head bolt threads and thread the bolt onto the stud.
- b. Hand turn the cylinder head bolt back and forth to loosen and remove carbon residue from the threads. Remove the bolt from the stud. Blow both thread sets with compressed air.

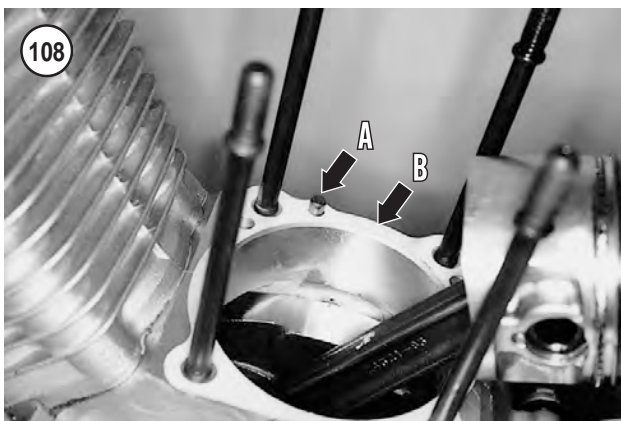

- c. Repeat until both thread sets are free of all carbon residue.
 - d. Spray the cylinder stud and cylinder head bolt with electrical contact cleaner and blow dry.
 - e. Set the cleaned bolt aside and install it on the same stud when installing the cylinder head.
5. Repeat Step 4 for each cylinder stud and cylinder head bolt set.

Installation

Refer to **Figure 98**.

1. Install the pistons and rings as described in this chapter.

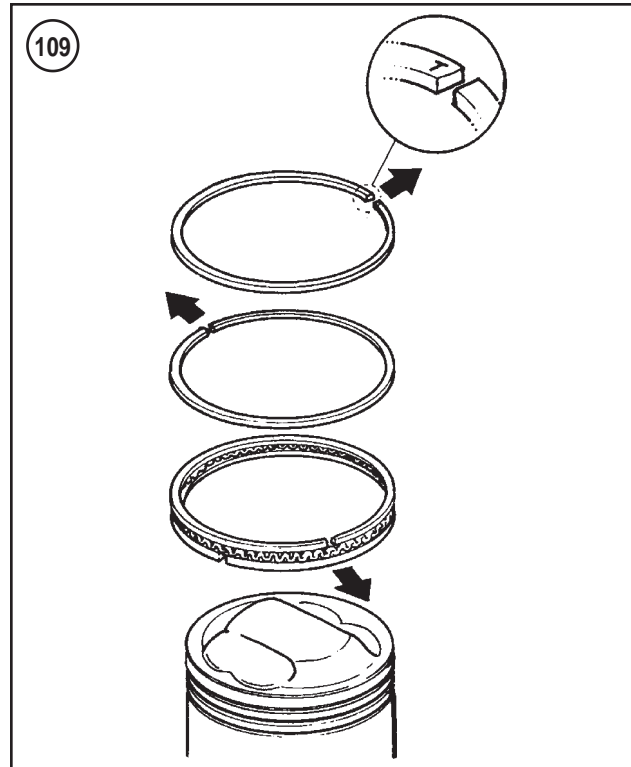

2. Check that all of the piston pin retaining rings (**Figure 107**) have been properly installed.
3. Remove all gasket residue and clean the cylinders as described in *Inspection* in this section.
4. Install the dowel pin (A, **Figure 108**), if removed. Install new O-ring
5. Install a new cylinder base gasket (B, **Figure 108**) onto the crankcase. Make sure all holes line up properly.
6. Turn the engine over until the piston is at top dead center (TDC).
7. Lubricate the cylinder bore and piston liberally with clean engine oil.
8. Slide the protective hoses off of the cylinder studs.
9. Position each piston ring so the end gap of adjacent rings is at least 90° apart (**Figure 109**). Ring gaps must not be within 10° of the piston's thrust face.
10. Compress the rings using a ring compressor (**Figure 110**).

11. Install the cylinders in their original positions. Align the cylinder with the cylinder studs and slide it down (**Figure 111**) until it is over the top of the piston. Continue sliding the cylinder down and past the rings. Once the rings are positioned in the cylinder, remove the ring compressor.
12. Continue to slide the cylinder down until it bottoms on the crankcase.
13. Repeat to install the remaining cylinder.
14. Install the cylinder heads as described in this chapter.

PISTONS AND PISTON RINGS

Refer to **Figure 98**.

Piston and Piston Rings Removal

1. Remove the cylinder head and cylinder as described in this chapter.
2. Stuff clean shop rags into the crankcase opening to prevent objects from falling into the crankcase.
3. Install a hose around each stud to protect the piston and studs from damage.
4. Install a piston holding tool to stabilize the piston. Construct the tool from wood as shown in **Figure 101**.
5. Lightly mark the pistons with an *F* (front) or *R* (rear) so they may be installed into the correct cylinder.

WARNING

Because the piston pin retaining rings are highly compressed in the piston pin ring groove, safety glasses must be worn during their removal and installation.

6. It is necessary to remove the retaining ring (**Figure 112**) on one side to remove the piston. Using a suitable tool, pry the retaining ring out of the piston. Place a finger over the hole to help prevent the ring from flying out during removal. Mark the piston rings so they can be reinstalled in their original connecting rods.
7. Support the piston and push out the piston pin (**Figure 113**). If the piston is difficult to remove, use a homemade tool as shown in **Figure 114**.

NOTE

If reusing the piston rings, identify and store the rings in a container so they can be reinstalled in their original ring grooves and on their original pistons.

8. Remove the old rings using a ring expander tool (**Figure 115**) or spread them with your fingers (**Figure 116**) and remove them.
9. Inspect the pistons, piston pins and pistons rings as described in this section.

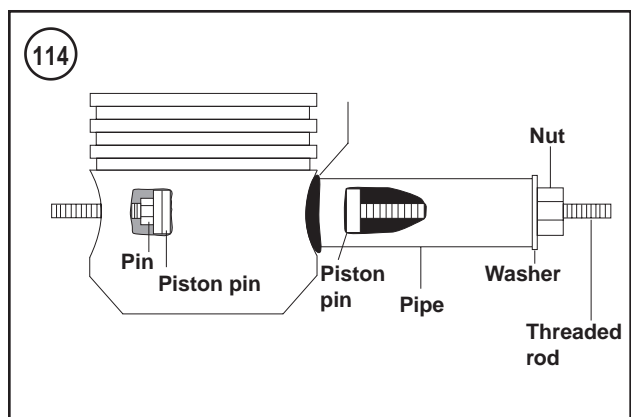

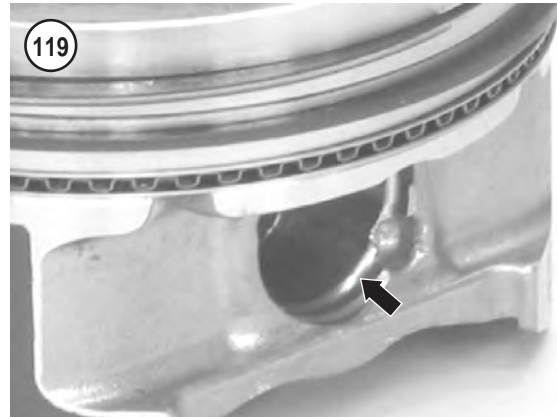
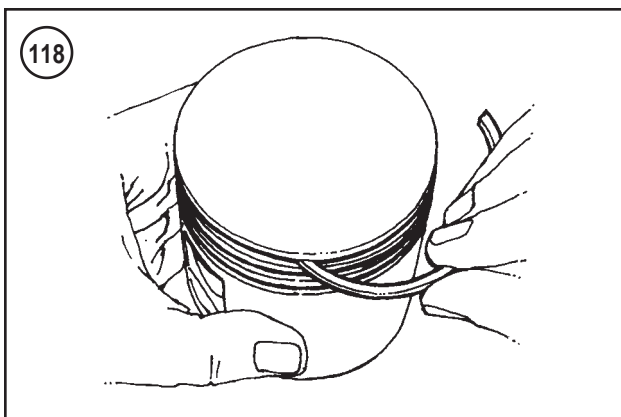
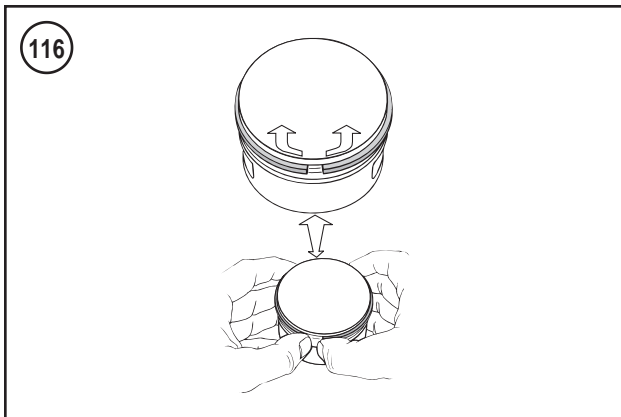
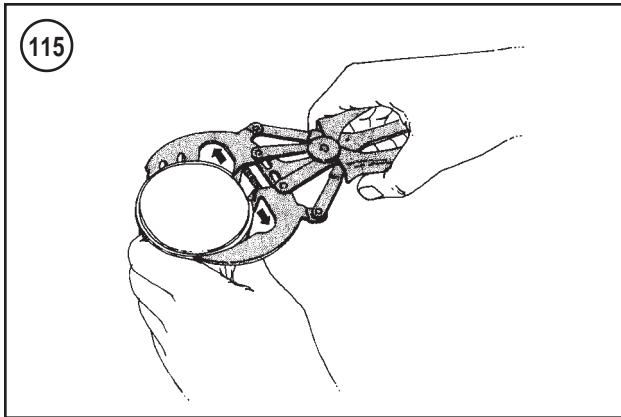

Piston Inspection

CAUTION

Do not damage the piston when removing carbon deposits. Do not use a wire brush to clean the ring grooves or piston sides. Do not remove carbon from the piston sides above the top ring groove or from the top of the cylinder bore. Carbon removal from these areas may cause increased oil consumption.

1. Carefully clean the carbon from the piston crown (**Figure 117**) with a soft scraper. Do not remove or damage the carbon ridge around the circumference of the piston above the top ring.
2. Using a broken piston ring, remove all carbon deposits from the piston ring grooves (**Figure 118**). Do not remove aluminum from the piston ring grooves when cleaning them.
3. After cleaning the piston, examine the crown. The crown should show no signs of wear or damage. If the crown appears pecked or spongy-looking, check the spark plug, valves and combustion chamber for aluminum deposits. If aluminum deposits are found, the engine is overheating.
4. Examine each ring groove for burrs, dented edges or other damage. Pay particular attention to the top compression ring groove as it usually wears more than the others. If the oil ring groove is worn or if the oil ring assembly is tight and difficult to remove, the piston skirt may have collapsed due to excessive heat and is permanently deformed. Replace the piston if damaged.
5. Check the piston skirt for cracks or other damage. If the piston skirt is worn or scuffed unevenly from side-to-side, the connecting rod may be bent or twisted. If a piston shows signs of partial seizure such as aluminum build-up on the piston skirt, replace the piston.
6. Inspect the retaining ring groove (**Figure 119**) on each side for wear, cracks or other damage. If the grooves are questionable, check the retaining ring fit by installing a new retaining ring into each groove, then attempt to move the retaining ring from side-to-side. If the retaining ring has

any side play, the groove is worn and the piston must be replaced.

7. If piston replacement is required, select a new piston as described in *Piston Clearance* in this section. If the piston, rings and cylinder are not damaged and are dimensionally correct, they can be reused.

Piston Pin Inspection

The piston pins used on 883 and 1200 models are different. The 1200 model piston pins are marked with a V-groove in one end of the pin (**Figure 120**). The 883 model pins are not marked. When purchasing replacement piston pins, note the difference.

1. Clean the piston pin in solvent and dry thoroughly.
2. Replace the piston pins if cracked, pitted or scored.
3. If the piston pins are visually okay, check their clearance as described in *Piston Pin Bushing Replacement* in this section.

Piston Clearance

Piston dimensions are not provided by the manufacturer. The cylinder bore must be machined to the correct dimension to provide the desired piston clearance. Refer to **Table 2** for cylinder bore dimension.

Piston Pin Bushing

Inspection

All models are equipped with a bushing (**Figure 121**) at the small end of the connecting rod. The bushing is reamed to provide correct piston pin clearance.

1. Inspect the piston pin bushing for wear or damage. Also check the bushing for a loose fit; the bushing must be a tight fit in the connecting rod.
2. Measure the piston pin outer diameter where it rides in the bushing (**Figure 122**).
3. Measure the piston pin bushing inner diameter.
4. Subtract the pin outer diameter from the bushing inner diameter to obtain the piston pin clearance.
5. Replace the pin and bushing if the clearance meets or exceeds the service limit in **Table 2**.

Replacement

1. The following tools are required to replace and ream the piston pin bushings. The clamp tool is only required if the bushing is being replaced with the crankcase assembled. If these tools are not available, have a shop with the proper equipment perform the procedure.

- a. Connecting rod clamp tool (part No. 1284 or HD-95952-33C).
- b. Connecting rod bushing tool (part No. 95970-32C).
- c. Bushing reamer tool (part No. 1726-2).

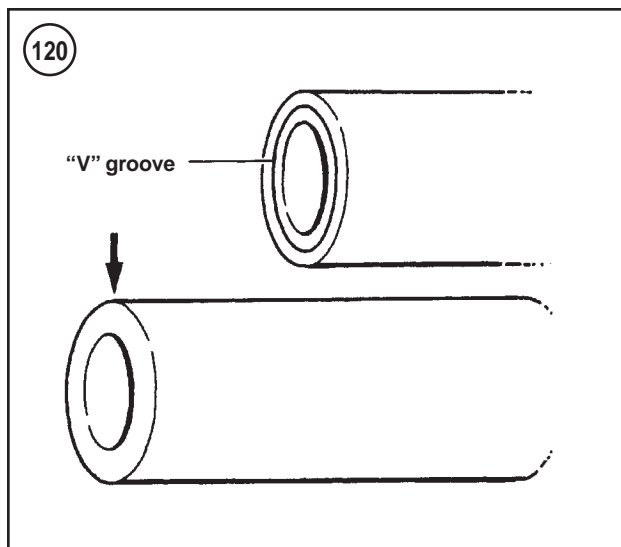

- d. Connecting rod bushing hone (part No. HD-35102).
 - e. Honing oil.
2. Remove two of the plastic hoses protecting the cylinder studs (B, **Figure 100**).
 3. Install the connecting rod clamping tool as follows:
 - a. Install the clamp portion of the connecting rod clamping tool around the connecting rod so the slots

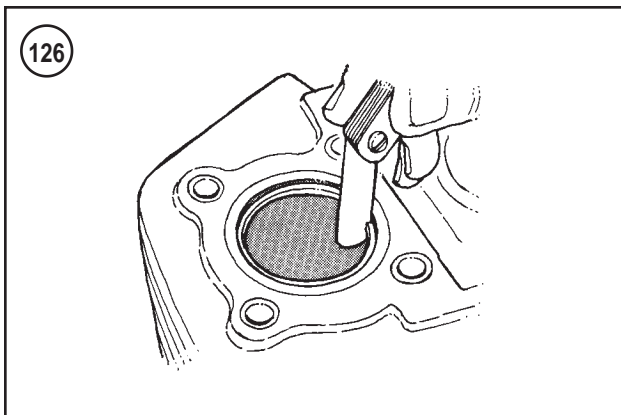
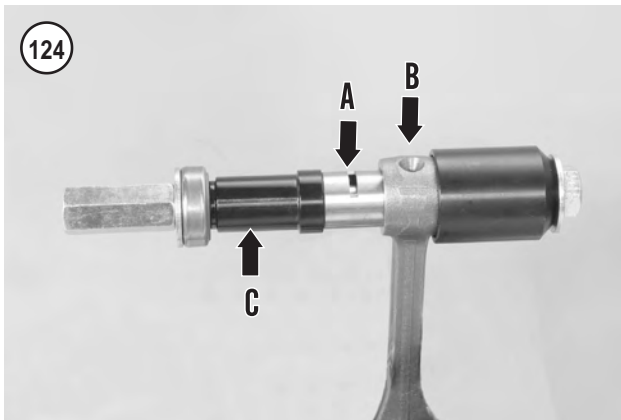
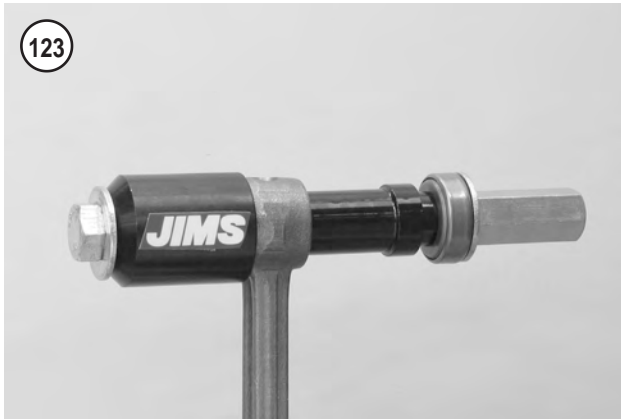

engage the cylinder head studs. Do not damage the studs.

- b. Position the threaded cylinders with the knurled end facing up and install the cylinders onto the studs. Tighten the clamp securely.
 - c. Alternately tighten the thumbscrews on the side of the connecting rod. Do not turn only one thumbscrew, as this will move the connecting rod off center and tightening the other thumbscrew will cause the connecting rod to flex or bend.
4. Cover the crankcase opening to keep bushing particles from falling into the engine.
 5. Assemble the removal tool per the manufacturer's instructions (**Figure 123**) and remove the bushing.

CAUTION

*When installing the new bushing, align the oil slot in the bushing (A, **Figure 124**) with the oil hole in the connecting rod (B).*

6. Replace the bushing using the connecting rod bushing tool (C, **Figure 124**) following the tool manufacturer's instructions. The new bushing must be flush with both sides of the connecting rod.
7. Ream the piston pin using the bushing reamer tool (**Figure 125**) following the manufacturer's instructions.
- 8.hone the new bushing to obtain the piston pin clearance specified in **Table 2**. Use honing oil, not engine oil, when honing the bushing to size.
9. Install the piston pin through the bushing. The pin should move through the bushing smoothly. Confirm pin clearance using a micrometer and bore gauge.

CAUTION

If the bushing clearance is less than 0.00125 in. (0.0317 mm), the pin may seize on the rod, causing engine damage.

10. Remove the shop rags from the crankcase openings making sure no debris falls into the opening and replace them with clean rags.

Inspection

1. Clean the piston ring grooves of all carbon residue as described in *Piston Inspection* in this section.
2. Inspect the ring grooves for burrs, nicks, or broken or cracked lands. Replace the piston if necessary.
3. Insert one piston ring into the top of its cylinder and tap it down about 1/2 in. (12.7 mm) with the piston to square it in the bore. Measure the ring end gap with a feeler gauge (**Figure 126**) and compare with specifications in **Table 2**. Replace the piston rings as a set if any one ring end gap measurement is excessive. Repeat for each ring.
4. Roll each compression ring around its piston groove as shown in **Figure 127**. The ring should move smoothly with no binding. If a ring binds in its groove, check the groove for damage. Replace the piston if necessary.

Installation

Each piston is equipped with three piston rings: two compression rings (**Figure 128**) and one oil ring assembly (**Figure 129**). The top compression ring is not marked. The second compression ring must be installed with its dot mark facing up.

Used piston rings must be installed on their original pistons and in their original grooves.

CAUTION

When installing oversize compression rings, check the number to make sure the correct rings are being installed. The ring numbers should be the same as the piston oversize number.

1. Wash the piston in hot, soapy water. Then rinse with cold water and blow dry. Make sure the oil control holes in the lower ring groove are clear and open.
2. Clean the piston rings carefully and dry with compressed air.
3. Install the oil ring assembly as follows:
 - a. The oil ring consists of three rings: a ribbed spacer ring (A, **Figure 129**) and two steel rings (B).
 - b. Install the spacer ring into the lower ring groove. Butt the spacer ring ends together. Do not overlap the ring ends.

CAUTION

Expand the rings just enough to install them. Expanding them too much distorts the rings.

- c. Insert one end of the first steel ring into the lower groove so that it is below the spacer ring. Then spiral the other end over the piston crown and into the lower groove. To protect the ring end from scratching the side of the piston, place a piece of shim stock or a thin, flat feeler gauge between the ring and piston.
 - d. Repeat sub-step c to install the other steel ring above the spacer ring.

CAUTION

*When installing the compression rings, use a ring expander as shown in **Figure 115**. Do not expand the rings any more than necessary to install them.*

4. Install the second compression ring as follows:
 - a. The second compression ring has a dot mark (**Figure 130**).
 - b. Install the second compression ring so that the dot mark faces upward.
5. Install the top compression ring as follows:
 - a. The top compression ring is not marked.
 - b. New upper compression rings can be installed with either side facing up. Used upper compression rings

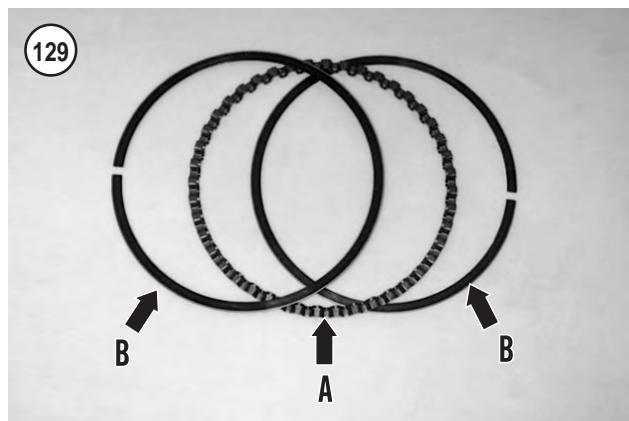
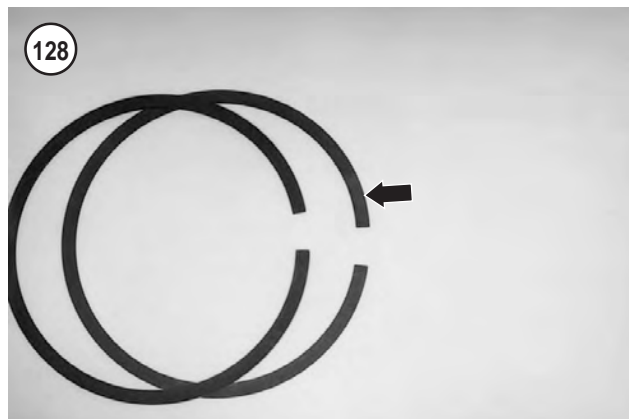
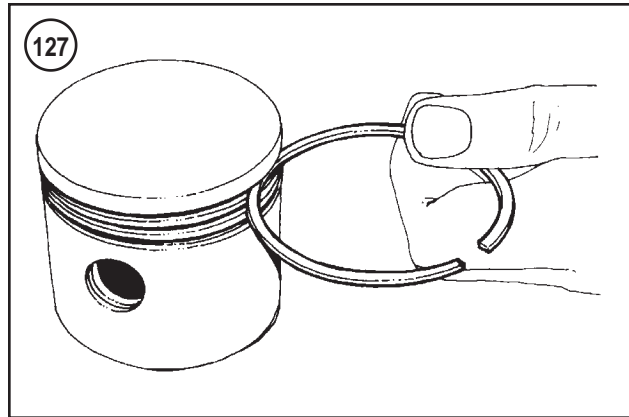

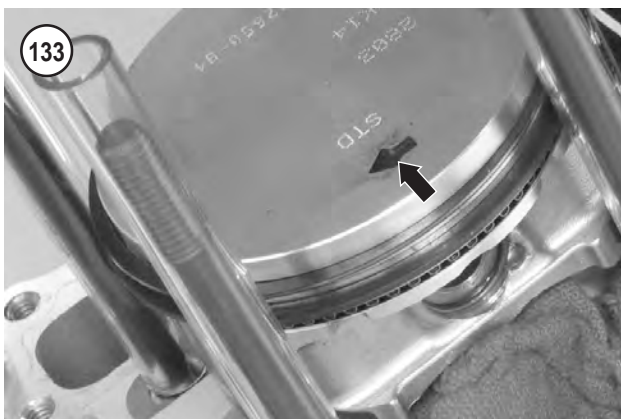
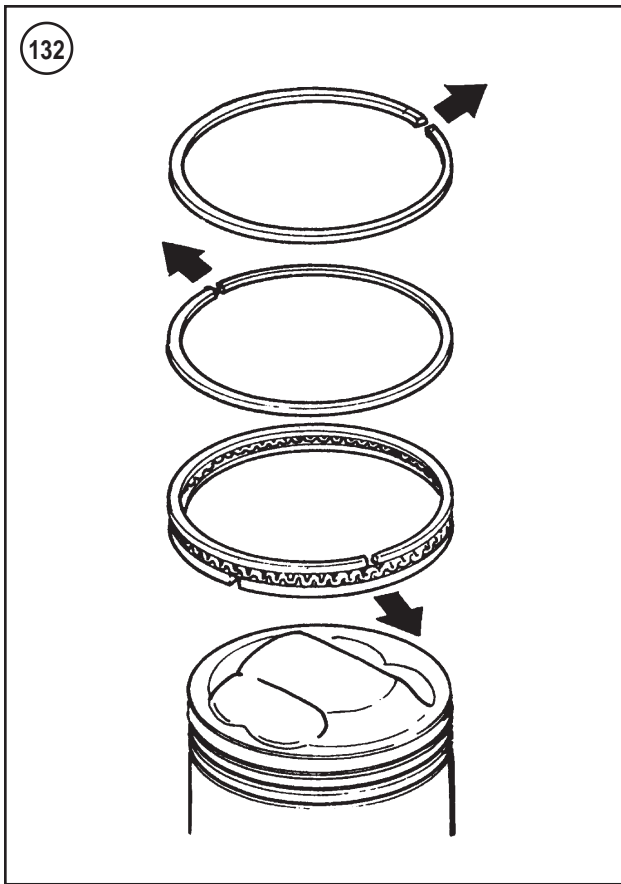
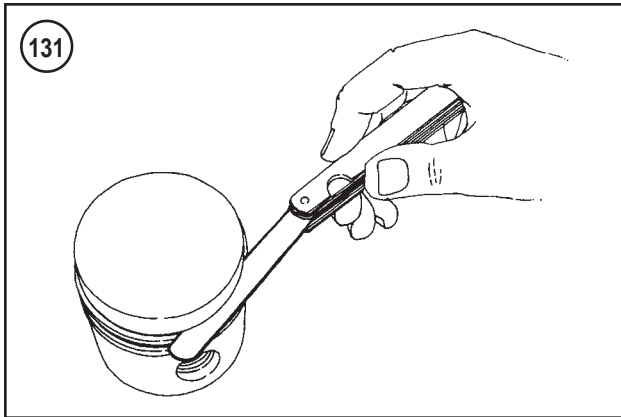

should be installed with their original top side facing up.

6. Check ring side clearance with a feeler gauge as shown in **Figure 131**. Check side clearance in several spots around the piston. If clearance meets or exceeds service limit in **Table 2**, note the following:

- If the ring grooves were not cleaned, remove the rings and clean the grooves. Then reinstall the rings and recheck clearance.
- If reusing the old rings, replace the rings and or the piston.
- If using new rings, replace the piston.

7. Stagger the ring gaps around the piston as shown in **Figure 132**. The ring gaps must not be within 10° of the piston's thrust face centerline.

Piston Installation

- Cover the crankcase openings with a clean shop towel to avoid dropping debris into the engine.
- Install a new piston pin retaining ring into one groove in the piston. Make sure the ring seats in the groove completely.
- Coat the connecting rod bushing and piston pin with assembly oil.

NOTE

The piston markings described in Step 4 are for original equipment pistons. If installing aftermarket pistons, follow the manufacturer's directions for piston alignment and installation.

- Place the piston onto the connecting rod with the arrow mark facing forward (**Figure 133**). Install used pistons on their original connecting rods; refer to the marks made on the piston during removal. Oversize pistons must be installed in the cylinder (front or rear) that they were originally fitted to during the boring process.
- Insert the piston pin through the piston. Hold the rod so that the lower end does not take any shock. Push the piston pin in until it contacts the retaining ring on the opposite side.
- Install the remaining new piston pin retaining ring (A, **Figure 134**). Make sure the ring end gap does not coincide with the notch on the side of the piston (B, **Figure 134**). Make sure the retaining ring seats in the groove completely.
- Install the cylinders as described in *Cylinder* section in this chapter.

OIL TANK AND OIL LINES

Hose Clamps

CAUTION

Discard removed hose clamps. Do not attempt to reuse removed clamps.

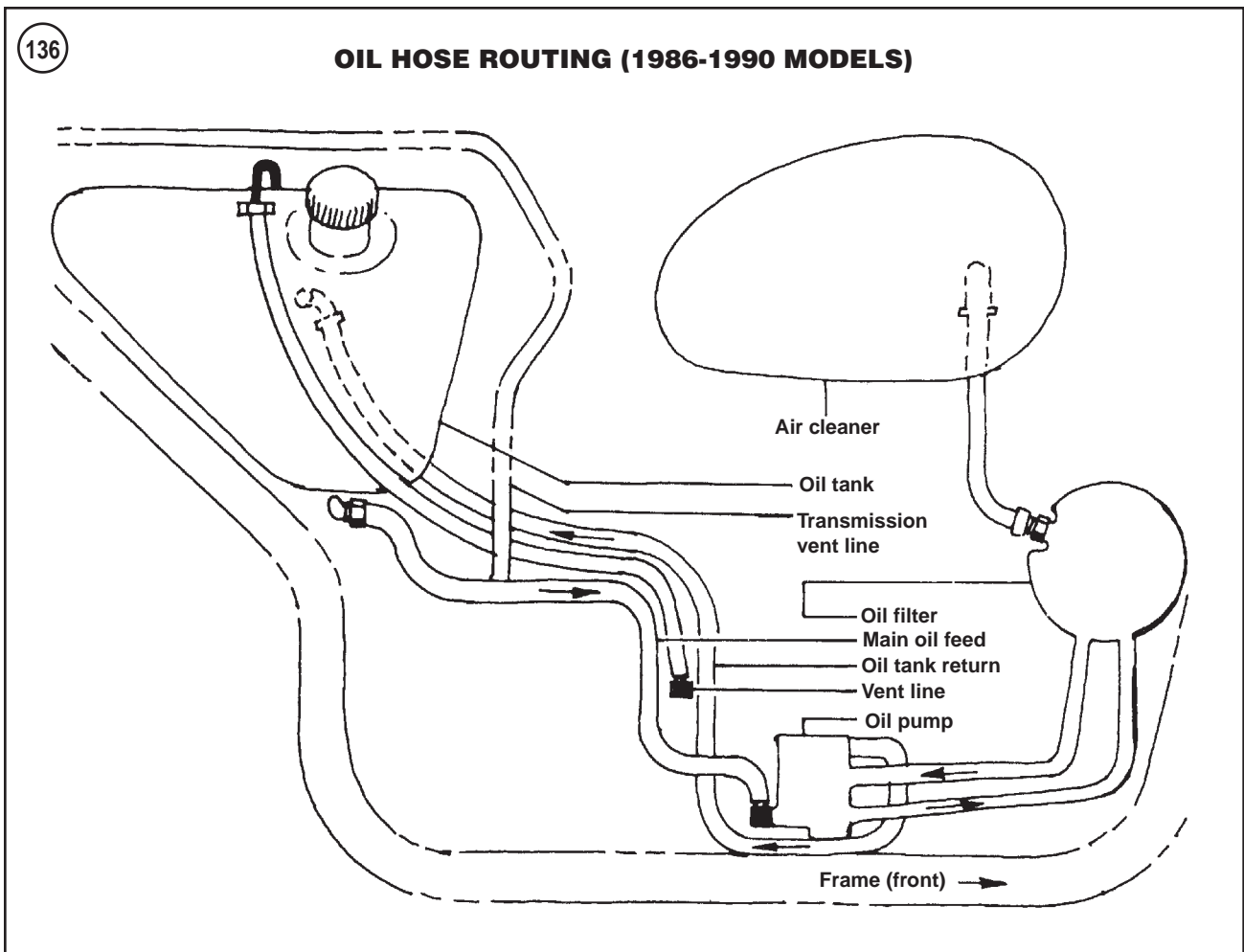
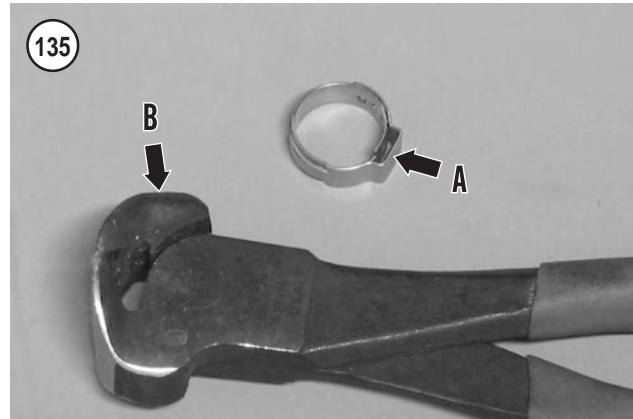
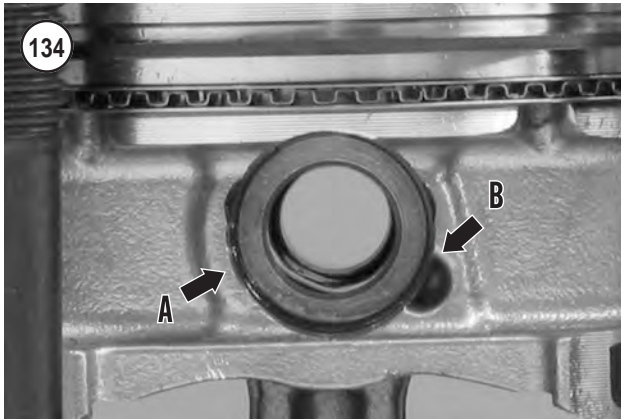

The oil hoses are secured by band-type hose clamps (A, **Figure 135**). Use diagonal pliers or other suitable tool to separate the clamp bands, then remove the clamp. Use hose clamp pliers (part No. HD-97087-65B or equivalent) to compress the clamp bands during installation.

checking the fit and integrity of the installed clamp.

Oil Lines

Refer to **Figures 136-138** for hose identification and routing. Replace all band-type clamps with new ones as described in this section. The threaded hose end fittings are

NOTE

*End cutting pliers (B, **Figure 135**) may be modified to compress the band clamps. Make sure to test the performance of the tool by*

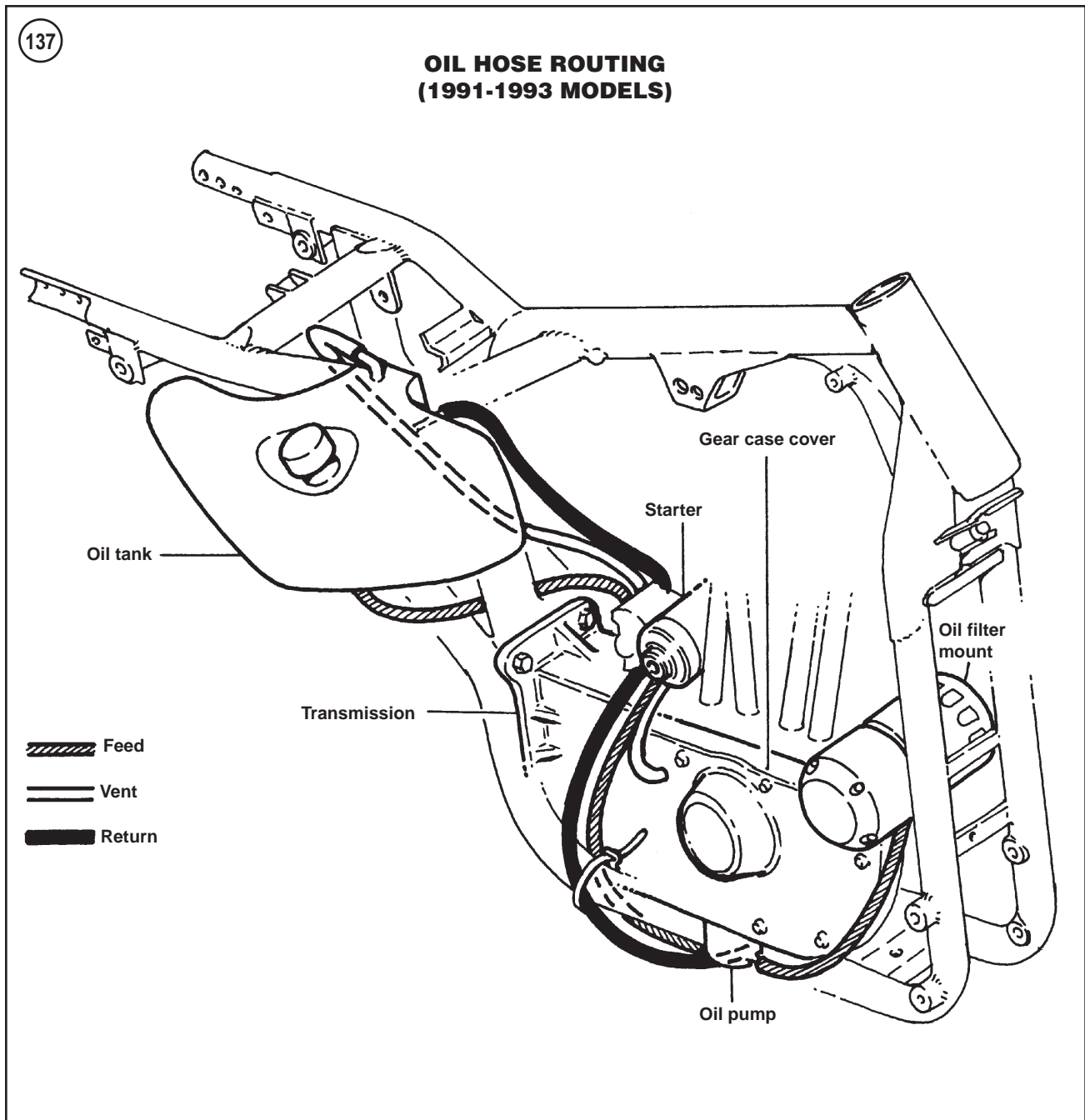

not replaceable; the fittings and hose are available only as a unit assembly.

Oil Tank

NOTE

An improved oil tank is available to replace the oil tank on 1986-1993 models.

Removal/installation

Refer to **Figures 136-138** when performing the following procedure.

1. Drain the oil tank (Chapter Three).
2. Remove the battery (Chapter Twelve).
3. Detach the ignition module connector from the battery tray by pushing the connector up (Chapter Twelve).
4. Unscrew the fasteners and remove the battery tray. Note the location of the positive battery cable retainer.
5. Remove the electrical component panel from the frame (Chapter Twelve).
6. Refer to **Figure 139**. Detach the vapor valve clip, disconnect the upper end of the valve from the hose and move the vapor valve out of the way.

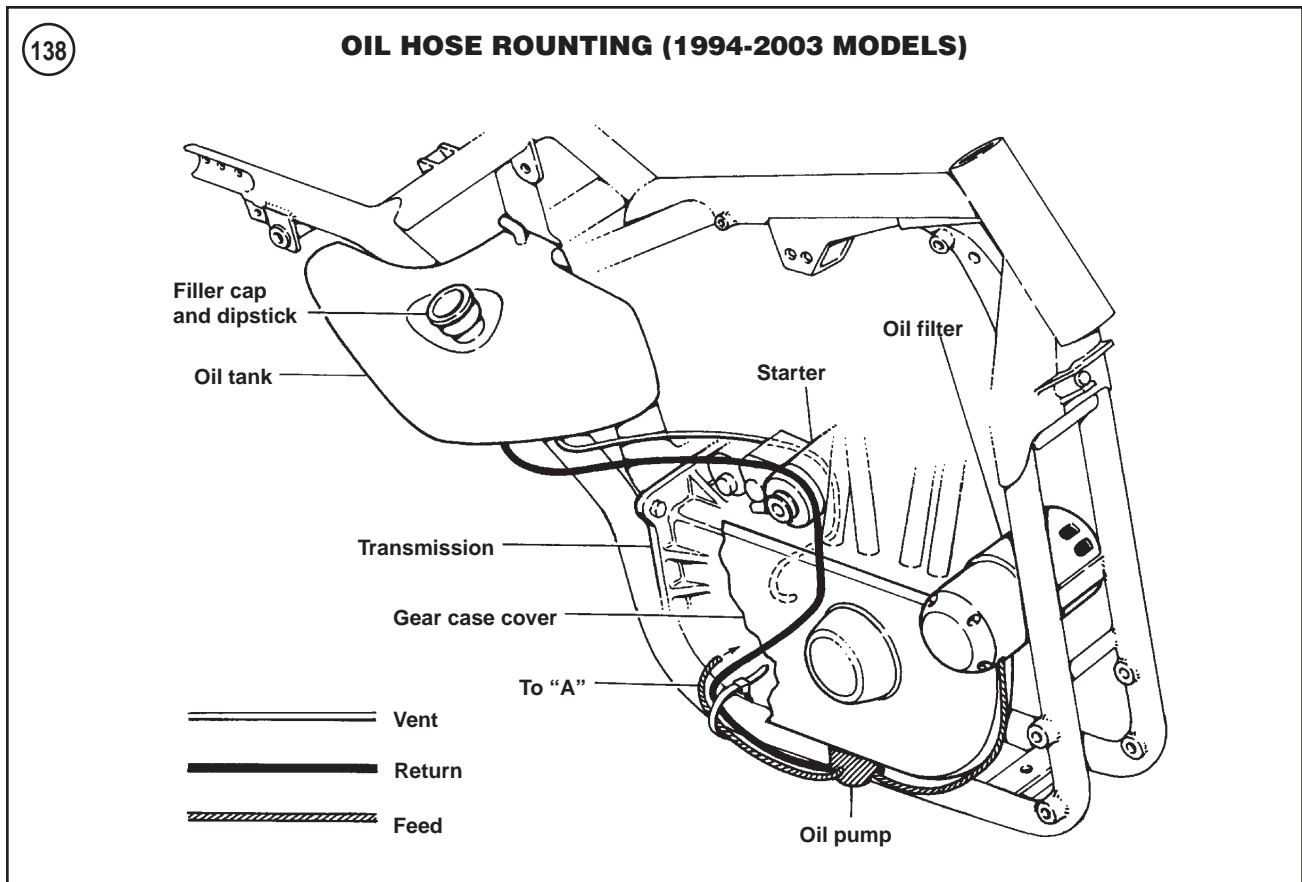

7. On California models, move the carbon canister purge hose out of the vapor valve bracket groove (Chapter Ten or Chapter Eleven).
8. On top of the oil tank cut the wiring harness cable strap.
9. Remove the oil tank mounting locknuts.
10. Mark and identify the oil hoses before detaching them from the oil tank. Move the oil tank sufficiently for access to the oil hoses, then disconnect the oil hoses from the oil tank.
11. Remove the oil tank.
12. If necessary, remove the rubber stud mounts from the oil tank. Replace them if damaged.
13. Reinstall the oil tank by reversing the removal steps while noting the following:
 - a. Tighten the oil tank mounting locknuts to 36-60 in.-lb. (4-7 N•m).
 - b. Make sure the long end of the vapor valve points up.

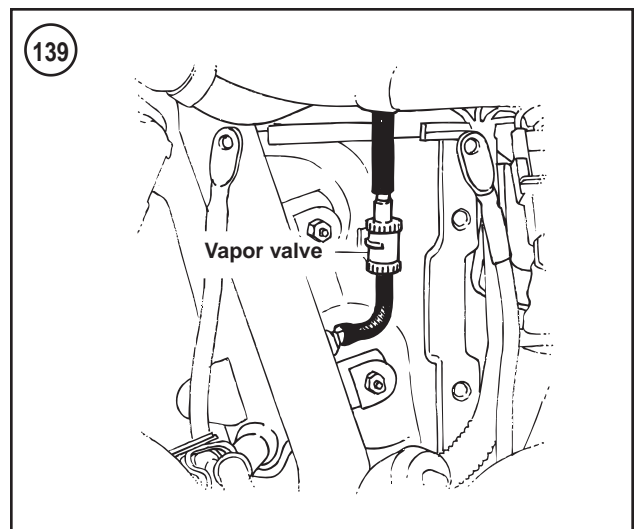

Table 1 GENERAL ENGINE SPECIFICATIONS

| | |
|--|--|
| Type | 45°,V-twin, air-cooled |
| Bore and stroke | |
| 883 models | 3.000 × 3.812 in. (76.2 × 96.8 mm) |
| 1100 models | 3.350 × 3.812 in. (85.1 × 96.8 mm) |
| 1200 models | 3.498 × 3.812 in. (88.85 × 96.8 mm) |
| Displacement | |
| 883 models | 53.9 cu. in. (883 cc) |
| 1100 models | 67.2 cu. in. (1102 cc) |
| 1200 models | 73.3 cu. in. (1203 mm) |
| Compression ratio | |
| All models except 1998-2003 1200S models | 9.0:1 |
| 1998-2003 1200S models | 10.0:1 |
| Compression pressure (at sea level) | approx. 120 psi (828 kPa) |
| Horsepower | |
| 1986-1990 | |
| 883 models | 52 @ 6000 rpm |
| 1100 models | 62 @ 6000 rpm |
| 1200 models | 68 @ 6000 rpm |
| 1991-1997 | |
| 883 models | 55 @ 6000 rpm |
| 1200 models | 65 @ 5200 rpm |
| 1998-2003 | |
| 883 models | 57 @ 6000 rpm |
| 1200 models (except 1200S models) | 66 @ 5200 rpm |
| 1200S models | 69 @ 5500 rpm |
| Torque | |
| 1986-1990 | |
| 883 models | 53 ft.-lb. (72 N•m) @ 4250 rpm |
| 1100 models | 63 ft.-lb. (85.4 N•m) @ 4000 rpm |
| 1200 models | 72 ft.-lb. (97.6 N•m) @ 4500 rpm |
| 1991-1992 | |
| 883 models | 55 ft.-lb. (74.5 N•m) @ 4500 rpm |
| 1200 models | 71.5 ft.-lb. (97 N•m) @ 4000 rpm |
| 1993-1997 | |
| 883 models | 50 ft.-lb. (68 N•m) @ 4600 rpm |
| 1200 models | 71 ft.-lb. (96 N•m) @ 4000 rpm |
| 1998-2003 | |
| 883 models | 53 ft.-lb. (72 N•m) @ 4500 rpm |
| 1200 models (except 1200S models) | 72 ft.-lb. (97.6 N•m) @ 4000 rpm |
| 1200S models | 76 ft.-lb. (103 N•m) @ 4000 rpm |

Table 2 ENGINE SERVICE SPECIFICATIONS

| | New in. (mm) | Service Limit in. (mm) |
|--------------------------------------|------------------------------------|---------------------------|
| Connecting rods | | |
| Piston pin clearance | 0.00125-0.00175 (0.0318-0.0445) | 0.002 (0.0508) |
| Cylinder | | |
| Taper | | 0.002 (0.0508) |
| Out-of-round | | 0.003 (0.076) |
| Gasket surface warp | | |
| Top | | 0.006 (0.152) |
| Bottom | | 0.008 (0.203) |
| Cylinder bore diameter (883 models)* | | |
| Standard | 3.0005 (76.213) | 3.0035 (76.289) |

(continued)

Table 2 ENGINE SERVICE SPECIFICATIONS

| | New in. (mm) | Service Limit in. (mm) |
|---|--------------------------------|-----------------------------------|
| Cylinder bore diameter (883 models)* (continued) | | |
| Oversize | | |
| 0.005 in. (0.13 mm) | 3.0048 (76.322) | 3.0078 (76.398) |
| 0.010 in. (0.25 mm) | 3.0098 (76.449) | 3.0128 (76.525) |
| 0.020 in. (0.51 mm) | 3.0198 (76.703) | 3.0228 (76.779) |
| 0.030 in. (0.76 mm) | 3.0298 (76.957) | 3.0328 (77.033) |
| 0.040 in. (1.02 mm) | 3.0398 (77.211) | 3.0428 (77.287) |
| Cylinder bore diameter (1100 models)* | | |
| Standard | 3.3505 (85.103) | 3.3535 (85.179) |
| Oversize | | |
| 0.005 in. (0.13 mm) | 3.3548 (85.212) | 3.3578 (85.288) |
| 0.010 in. (0.25 mm) | 3.3598 (85.339) | 3.3628 (85.415) |
| 0.020 in. (0.51 mm) | 3.3698 (85.593) | 3.3728 (85.669) |
| 0.030 in. (0.76 mm) | 3.3798 (85.847) | 3.3828 (85.923) |
| 0.040 in. (1.02 mm) | 3.3898 (86.101) | 3.3928 (86.177) |
| Cylinder bore diameter (1200 models)* | | |
| Standard | 3.4978 (88.844) | 3.5008 (88.920) |
| Oversize | | |
| 0.005 in. (0.13 mm) | 3.502 (88.951) | 3.505 (89.027) |
| 0.010 in. (0.25 mm) | 3.507 (89.078) | 3.510 (89.154) |
| 0.020 in. (0.51 mm) | 3.517 (89.332) | 3.520 (89.408) |
| 0.030 in. (0.76 mm) | 3.527 (89.586) | 3.530 (89.662) |
| Cylinder head | | |
| Gasket surface warp | 0.006 (0.152) | 0.006 (0.152) |
| Valve guide fit in head | 0.0033-0.0020 (0.084-0.051) | — |
| Valve seat fit in head | 0.0035-0.0010 (0.089-0.025) | — |
| Piston (883 and 1100 models) | | |
| Compression ring end gap | 0.010-0.023 (0.254-0.584) | 0.032 (0.813) |
| Oil control ring rail end gap | 0.010-0.053 (0.254-1.346) | 0.065 (1.651) |
| Compression ring side clearance | | |
| Top | 0.0020-0.0045 (0.051-0.114) | 0.0065 (0.165) |
| Second | 0.0020-0.0045 (0.051-0.114) | 0.0065 (0.165) |
| Oil control ring side clearance | 0.0014-0.0074 (0.036-0.188) | 0.0094 (0.239) |
| Piston (1200 models) | | |
| Compression ring end gap | 0.007-0.020 (0.178-0.508) | 0.032 (0.813) |
| Oil control ring rail end gap | 0.009-0.052 (0.229-1.321) | 0.065 (1.651) |

(continued)

Table 2 ENGINE SERVICE SPECIFICATIONS

| | New in. (mm) | Service Limit in. (mm) |
|---|--------------------------------|-----------------------------------|
| Piston (1200 models) | | |
| Compression ring side clearance | | |
| Top | 0.0020-0.0045 (0.051-0.114) | 0.0065 (0.165) |
| Second | 0.0016-0.0041 (0.041-0.104) | 0.0065 (0.165) |
| Oil control ring side clearance | | |
| | 0.0016-0.0076 (0.041-0.193) | 0.0094 (0.239) |
| Rocker arm | | |
| Shaft fit in bushing | 0.0005-0.0020 (0.013-0.051) | 0.0035 (0.089) |
| End clearance | 0.003-0.013 (0.08-0.33) | 0.025 (0.635) |
| Bushing fit in rocker arm | 0.0040-0.0020 (0.102-0.051) | – |
| Rocker arm shaft | | |
| Shaft fit in cover | 0.0007-0.0022 (0.018-0.056) | 0.0035 (0.089) |
| Valves | | |
| Guide-to-valve stem clearance | | |
| Intake | 0.0008-0.0026 (0.020-0.066) | 0.0035 (0.089) |
| Exhaust | 0.0015-0.0033 (0.038-0.084) | 0.0040 (0.102) |
| Seat width | | |
| | 0.040-0.062 (1.016-1.575) | 0.090 (2.286) |
| Stem protrusion from cylinder valve pocket | | |
| | 1.975-2.011 (50.165-51.079) | 2.031 (51.587) |
| Valve spring free length | | |
| Outer spring | 2.105-2.177 (53.467-55.296) | 2.105 (53.467) |
| Inner spring | 1.926-1.996 (48.92-50.70) | 1.926 (48.92) |
| *±0.0002 in. (0.005 mm) | | |

Table 3 VALVE SPRING COMPRESSION SPECIFICATIONS

| | Compression length in. (mm) | Pressure lb. (kg) |
|---------------------|--|------------------------------|
| Outer spring | | |
| Intake | | |
| Closed | 1.751-1.848 (44.46-46.94) | 72-92 (32.7-41.7) |
| Open | 1.286-1.383 (32.66-35.13) | 183-207 (83.0-93.9) |
| Exhaust | | |
| Closed | 1.751-1.848 (44.47-46.94) | 72-92 (32.7-41.7) |
| Open | 1.332-1.429 (33.83-36.30) | 171-195 (77.6-88.5) |
| Inner spring | | |
| Intake | | |
| Closed | 1.577-1.683 (40.05-42.74) | 38-49 (17.24-22.23) |
| Open | 1.112-1.218 (28.44-30.94) | 98-112 (44.45-50.80) |
| Exhaust | | |
| Closed | 1.577-1.683 (40.06-42.75) | 38-49 (17.24-22.23) |
| Open | 1.158-1.264 (29.41-32.11) | 91-106 (41.3-48.1) |

Table 4 ENGINE TORQUE SPECIFICATIONS

| | ft.-lb. | in.-lb. | N•m |
|--------------------------------|----------------|----------------|------------|
| Breather valve retaining screw | – | 35-55 | 4-6 |
| Cylinder head bolts* | | | |
| Engine mounts | | | |
| Engine bolts | 25-30 | – | 34-41 |
| Frame bolts | 30-35 | – | 41-47 |
| Lower rocker cover bolts | | | |
| 5/16 in. | 15-18 | – | 20-24 |
| 1/4 in. | – | 120-156 | 14-18 |
| Oil tank mounting locknuts | – | 36-60 | 4-7 |
| Pushrod tube seal plate bolts | 15-18 | – | 20-24 |
| Rocker cover bolts | – | 120-156 | 14-18 |
| Spark plug | 11-18 | – | 15-24 |
| *Refer to text. | | | |

CHAPTER FIVE

ENGINE LOWER END

This chapter covers lower end engine components and engine removal and installation procedures. **Tables 1-3** are at the end of this chapter.

TOOLS

Engine service requires a number of special tools. These tools and their part numbers are listed with the individual procedures. For a complete list of the special tools mentioned in this manual, refer to **Table 12** in Chapter One.

When purchasing tools from a dealership or parts supplier, be sure to specify the tools required are for the specific Sportster model being worked on. Many of the tools are specific to the engine. Tools for other engine models may be slightly different.

The manufacturer's part number is provided for many of the tools mentioned in this manual. These part numbers are correct at the time of original publication. The publisher cannot guarantee the part number or the tools in this manual will be available in the future.

ENGINE SERVICE

Many components can be serviced while the engine is mounted in the frame:

1. Rocker arm cover and rocker arms.

2. Cylinder heads.
3. Cylinders and pistons.
4. Camshafts.
5. Gearshift mechanism.
6. Clutch and primary drive assembly.
7. Transmission
8. Carburetor.
9. Starter and gears.
10. Alternator and electrical systems.

ENGINE STAND

Most engine service can be performed with the engine supported in an engine stand. An engine stand permits engine service with the engine removed from the frame. Engine work can be performed on a stable platform that lessens the possibility of engine damage due to droppage or an unsuitable work surface.

ENGINE

Removal

1. Remove the battery and battery tray as described in Chapter Twelve.
2. Remove the fuel tank as described in Chapter Ten or Chapter Eleven.

3. Drain the transmission oil as described in Chapter Three.
4. Remove the exhaust system as described in Chapter Ten or Chapter Eleven.
5. Remove the air filter assembly and backplate as described in Chapter Ten or Chapter Eleven.
6. Remove the horn as described in Chapter Twelve.
7. On 1986-1994 models, disconnect the ignition switch wires and remove the ignition switch and enricher knob bracket (**Figure 1**).
8. Disconnect the spark plug wires and set them out of the way.
9. Remove the ignition coil as described in Chapter Ten or Chapter Eleven.
10. On 1995-2003 models, remove the enricher knob bracket mounting screw. Secure the enricher knob so it is out of the way.
11. On all models except 1998-2003 1200S models, remove the vacuum hose (**Figure 2**) from the VOES fitting on the carburetor, and disconnect the VOES electrical connector at the ignition module.
12. Remove the carburetor as described in Chapter Ten or Chapter Eleven.
13. On 883C and 1200C models, remove the footrest assemblies as described in Chapter Seventeen.
14. Remove the top center engine mount (**Figure 3**) as follows:

- a. Remove the bolts, washers and lockplate securing the top center engine mount to the frame. Check for a shim (9, **Figure 3**) mounted between the top center engine mount and frame; this shim is not used on all models.
- b. Remove the enricher knob (**Figure 4**) if it was not removed with the carburetor.
- c. Loosen the bolts securing the top center engine mount to the cylinder heads.
- d. Remove the bolts (A, **Figure 5**), flat washers and lockwashers.
- e. On 1986-1993 models, remove the VOES ground wire (**Figure 6**) when removing the rear cylinder head bolt and set the wire aside. Check the VOES wire for damage. Repair the wire or connector, if necessary, before reinstalling the engine.
- f. Remove the top center engine mount (B, **Figure 5**) and shim (if used).

15. Remove the top front engine mount (**Figure 7**) as follows:
 - a. Pry off the side reflectors (**Figure 8**) from the front frame tubes. See **Figure 9**.
 - b. Loosen then remove the bolts (A, **Figure 10**) and washers securing the top front engine mount to the frame mounting bracket. Remove the nut plate (5, **Figure 7**) from the frame mounting bracket.
 - c. Loosen the bolt (B, **Figure 10**) and nut securing the top front engine mount to the front cylinder block.
 - d. Remove the bolt, nut, lockwashers and flat washers.
 - e. Remove the top front engine mount (C, **Figure 10**).

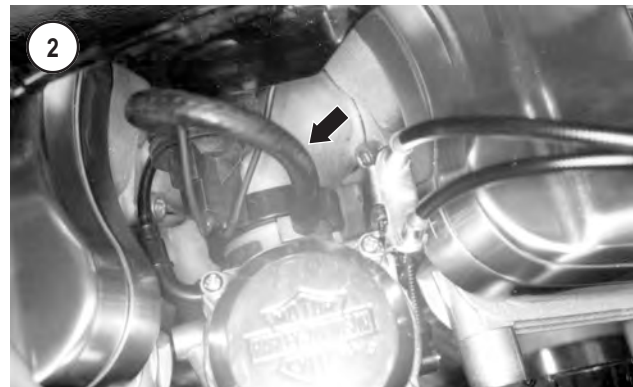

16. Remove the rear sprocket cover (A, **Figure 11**) as follows:

- a. Loosen then remove the rear brake master cylinder mounting bolts (B, **Figure 11**) and washers.

NOTE

It is not necessary to disconnect the brake line at the master cylinder.

- b. Remove the clevis pin (**Figure 12**) cotter pin at the rear brake pedal. Then remove the clevis pin and disconnect the brake pedal from the brake rod end.
 - c. Remove the screw and clip (C, **Figure 11**) securing the brake line to the sprocket cover.
 - d. Loosen then remove the bolts and washers securing the sprocket cover (A, **Figure 11**) to the engine. Remove the sprocket cover together with rear brake pedal and linkage assembly.
17. Loosen the rear axle nut and the rear drive chain or drive belt adjusters. Then slip the drive chain or drive belt (**Figure 13**) off the drive sprocket. Refer to Chapter Thirteen.
 18. Disconnect the oil pressure switch electrical connector (**Figure 14**).

NOTE

Figure 15 shows the neutral switch with the drive sprocket removed for clarity. The neutral switch connector can be disconnected with the drive sprocket mounted on the motorcycle.

3

TOP CENTER ENGINE MOUNT

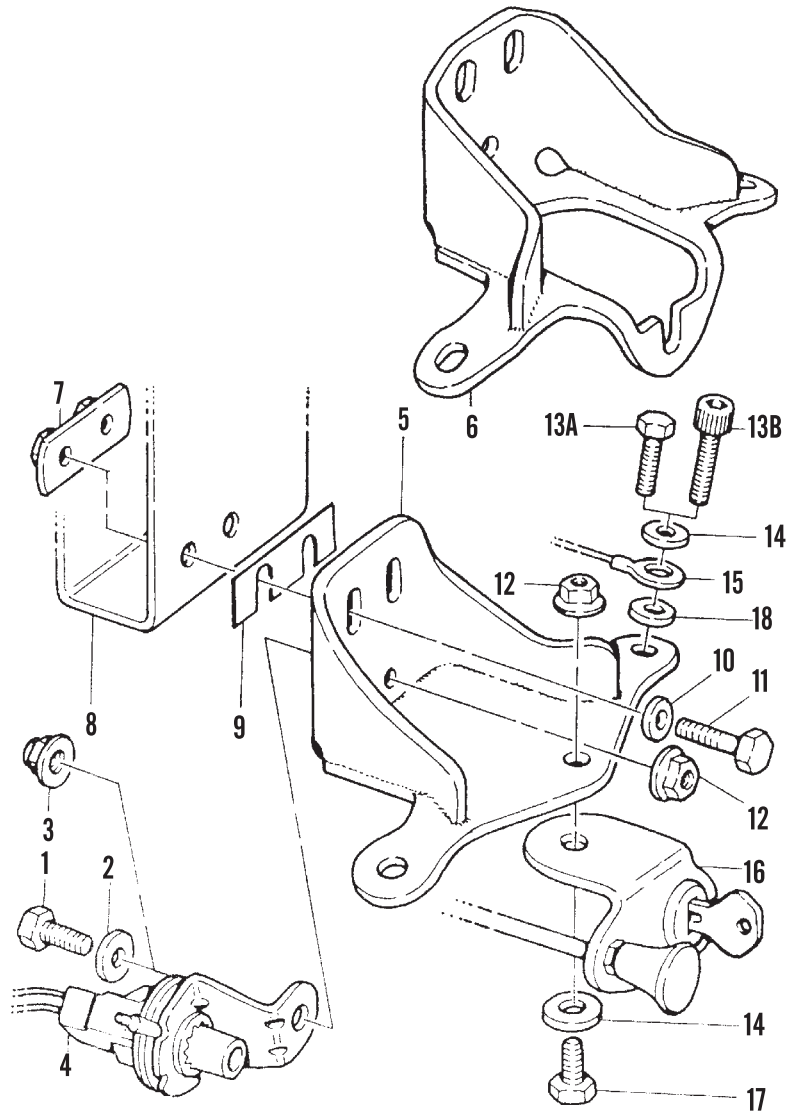

- | | |
|--|--|
| 1. Bolt | 11. Bolt |
| 2. Washer (1986-1991 models) | 12. Locknut |
| 3. Locknut (1992-2003 models) | 13A. Bolt (1986-1991 models) |
| 4. VOES (all models except 1998-2003 1200S models) | 13B. Bolt (1992-2003 models) |
| 5. Top center engine mount (1986-1994 models) | 14. Lockwasher (1986-1994 models)/ Washer (1995-2003 models) |
| 6. Top center engine mount (1995-2003 models) | 15. VOES ground wire (1986-1993 models) |
| 7. Nut plate | 16. Ignition bracket (1986-1994 models) |
| 8. Frame | 17. Bolt |
| 9. Shim | 18. Washer (1986-1994 models) |
| 10. Washer | |

19. Disconnect the neutral switch electrical connector from the switch (**Figure 15**).
20. Disconnect the ignition timer plate wires from the wiring harness (**Figure 16**, typical).
21. Disconnect the regulator/rectifier electrical connector(s) from the alternator stator connector. See **Figure 17** (1986-1993 models) or **Figure 18** (1994-2003 models).
22. Disconnect the clutch cable from the handlebar.
23. Drain the engine oil tank as described in Chapter Three.
24. Label, then disconnect the oil feed, return and vent hoses at the oil tank. See **Figure 19** (1986-1990 models), **Figure 20** (1991-1993 models) or **Figure 21** (1994-2003 models). Plug each hose and hose fitting to prevent oil leaks and contamination.
25. Place a jack and a piece of plywood under the engine. Do not apply pressure against the engine until all of the engine mounting bolts and nuts have been loosened.
26. Loosen the left and right lower front engine mount bolts and nuts (**Figure 22**).
27. Disconnect the negative battery ground cable from the upper left rear engine mount bolt; see **Figure 23**.
28. Loosen the upper (**Figure 24**) and lower (**Figure 25**) rear engine mount bolts. See **Figure 26**.
29. Raise the jack enough to take the engine weight off the bolts. Remove the bolts.
30. Remove the left and right lower front engine mount bolts, washers and nuts. Then remove the left and right mounting plates. See **Figure 22**.
31. Remove the rear engine mount bolts, lockwashers, flat washers and nuts. See **Figure 26**.
32. To avoid scratching the frame, wrap the exposed frame tubes with cardboard or plastic tubes.
33. Check the engine to make sure all wiring, hoses and other components have been disconnected or removed.
34. With help from an assistant, lift the engine up and remove it from the right side of the frame. If the cylinder heads are still mounted on the engine, tip the cylinder heads slightly off center to prevent them from contacting the upper frame rail.

CAUTION

Do not lay the engine on the left side with the clutch installed or the clutch cable adjusting screw will be damaged.

35. Mount the engine in an engine stand or take it to a workbench for further disassembly.

Inspection

1. Clean the frame.
2. Inspect the frame for cracks or other damage. If found, have the frame inspected by a dealership or frame alignment specialist.
3. If paint has been removed from the frame during engine removal or cleaning, touch up as required

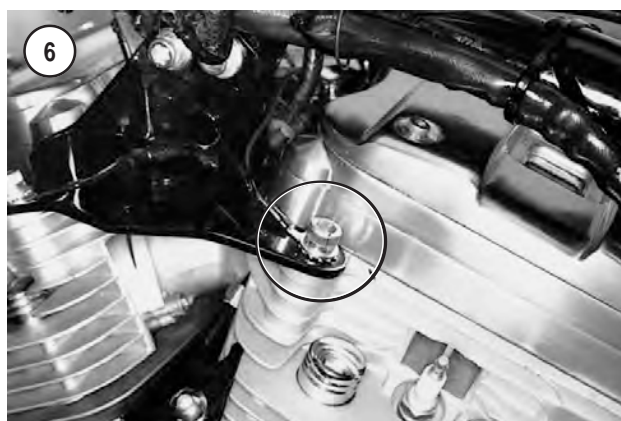

4. While the engine is removed, remove the oil tank and thoroughly flush (Chapter Four). Then reinstall the oil tank and plug the oil hoses to prevent contamination.
5. Replace any worn or damaged oil hoses and clamps (Chapter Four).
6. Check the exposed hoses and cables for chafing or other damage. Replace loose, missing or damaged hose clamps and cable ties.
7. Check all of the engine mounting fasteners for corrosion and thread damage. Clean each fastener in solvent to remove oil and threadlock residue. Replace worn or damaged fasteners before reassembly.

7

TOP FRONT ENGINE MOUNT

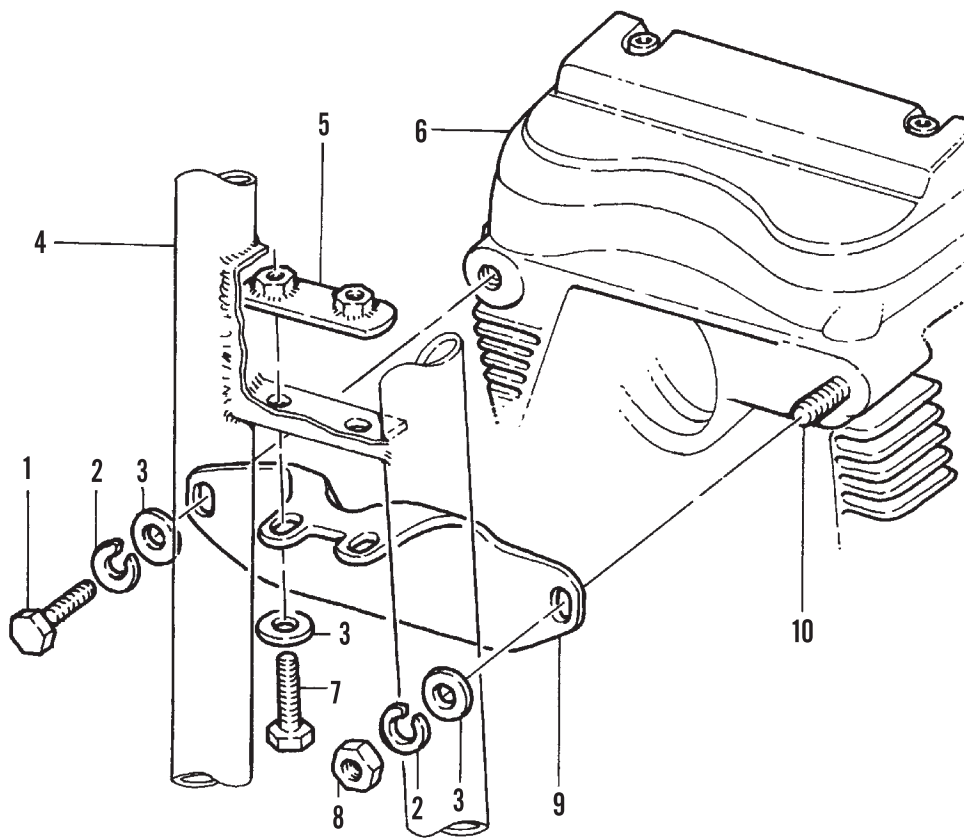

- 1. Bolt
- 2. Lockwasher
- 3. Washer
- 4. Frame downtube
- 5. Nut plate
- 6. Engine
- 7. Bolt
- 8. Nut
- 9. Top front engine mount
- 10. Stud

5



8. Inspect the wiring harness for signs of damage that may have occurred when removing the engine. Repair or replace damaged wires as required.

Installation

1. Make sure the frame is supported properly before installing the engine. The jack and piece of plywood will not be required until after the engine is resting in the frame.
2. Be sure all clamps or ties are in place before engine installation. See **Figure 27** and **Figure 28**.
3. Lay out the engine mount plates and fasteners in the order shown in **Figure 22** and **Figure 26**.
4. If the frame protectors were removed, reinstall them.
5. Position all of the wiring connectors and hoses so that they are out of the way when installing the engine.
6. Place the engine in the frame from the right side.
7. Slide the jack with the piece of plywood underneath the engine. Use the jack to align the rear engine-to-frame mounting holes. Insert the lower engine dowel pins into the rear frame engine mount bracket as shown in **Figure 29**.
8. Apply an antiseize lubricant to all of the engine mounting bolts prior to installation.
9. To install the rear engine mount assembly (**Figure 26**), perform the following:
 - a. Install a flat washer on the two upper engine mount bolts and install the bolts through the frame and engine. Install the locknut and washer on the right bolt. Install the hex nut and washer on the left bolt. Do not install the battery ground cable at this time.
 - b. Install a lockwasher and flat washer on the two lower engine mount bolts and install the bolts through the frame and thread into the engine hand-tight.
10. Install the left and right lower front engine mount plates, bolts, washers and nuts as shown in **Figure 22**. Tighten the bolts hand-tight.
11. Tighten the rear engine mounting bolts and nuts (**Figure 26**) to 25-30 ft.-lb. (34-41 N•m).
12. Tighten the lower front engine bolts (A, **Figure 30**) to 25-30 ft.-lb. (34-41 N•m). Tighten the lower front frame bolts (B, **Figure 30**) to 25-30 ft.-lb. (34-41 N•m).
13. Install the top center engine mount assembly (**Figure 31**) as follows:
 - a. Install the top center engine mount bolts and washers through the engine mount.
 - b. Place the shim (if used) onto the top center engine mount bolts.

NOTE

Three different shim thicknesses are available: 0.030 in. (0.076 mm), 0.060 in. (1.52 mm) and 0.090 in. (2.27 mm). When installing an engine that did not have any major components replaced (engine cases, cylinder heads, top center engine mount or frame), the original thickness shim can be installed. If one of

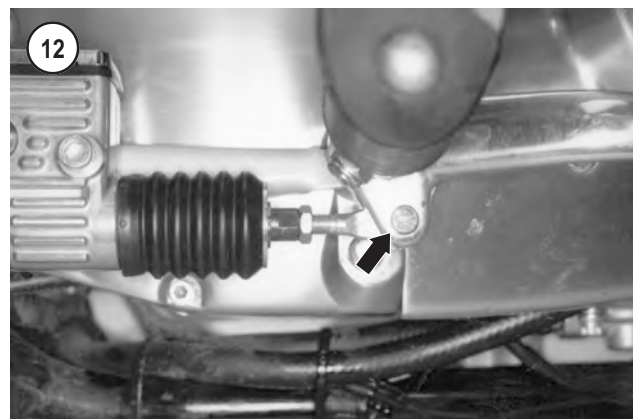
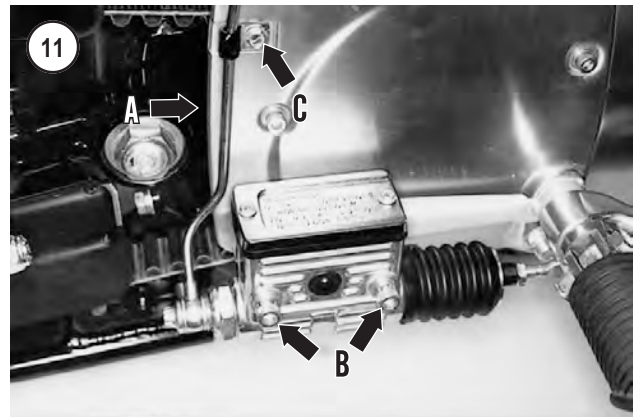

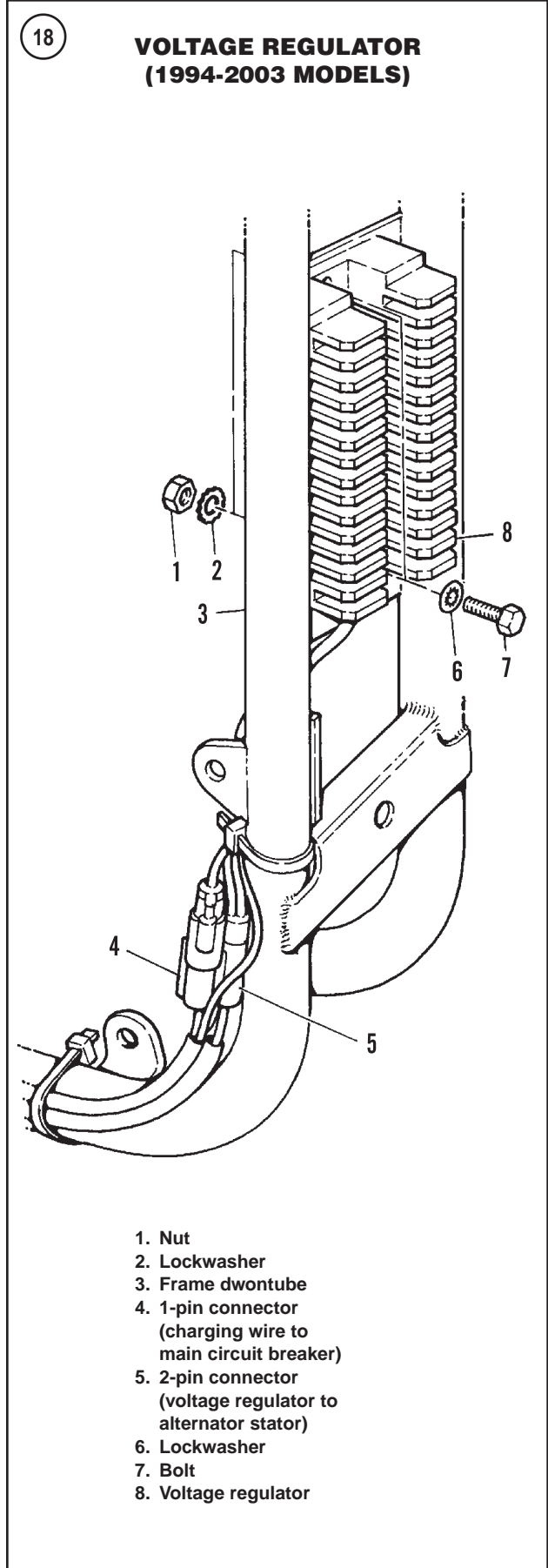

19

OIL HOSE ROUTING (1986-1990 MODELS)

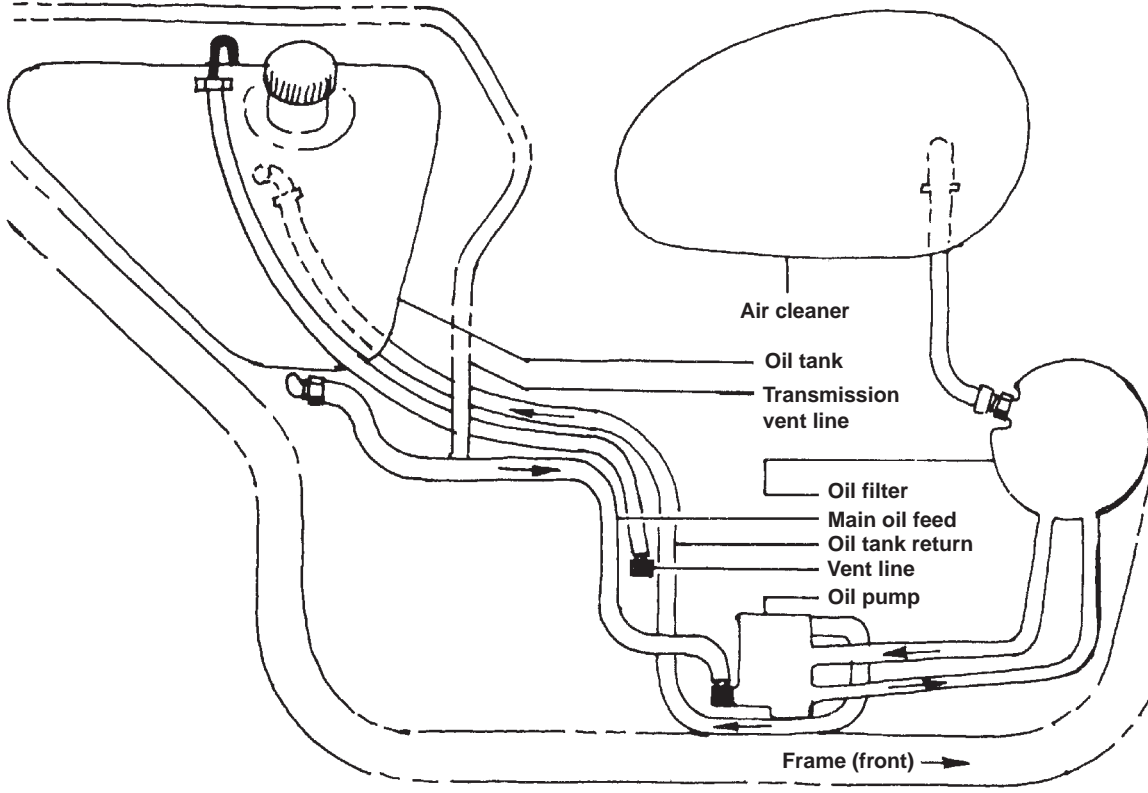

20

OIL HOSE ROUTING (1991-1993 MODELS)

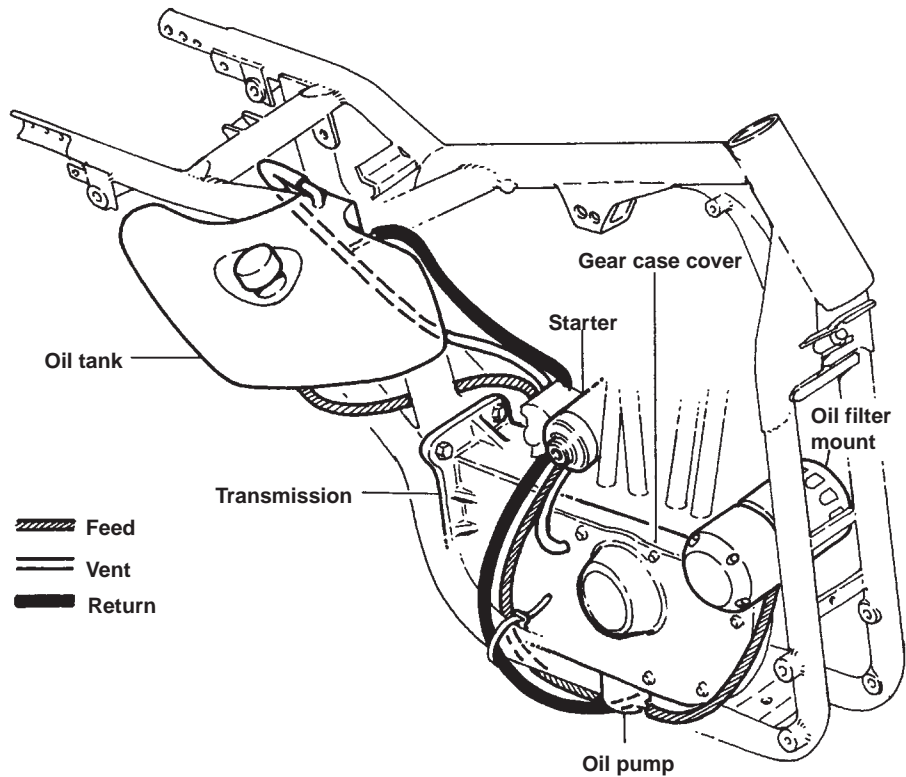

21

OIL HOSE ROUTING (1994-2003 MODELS)

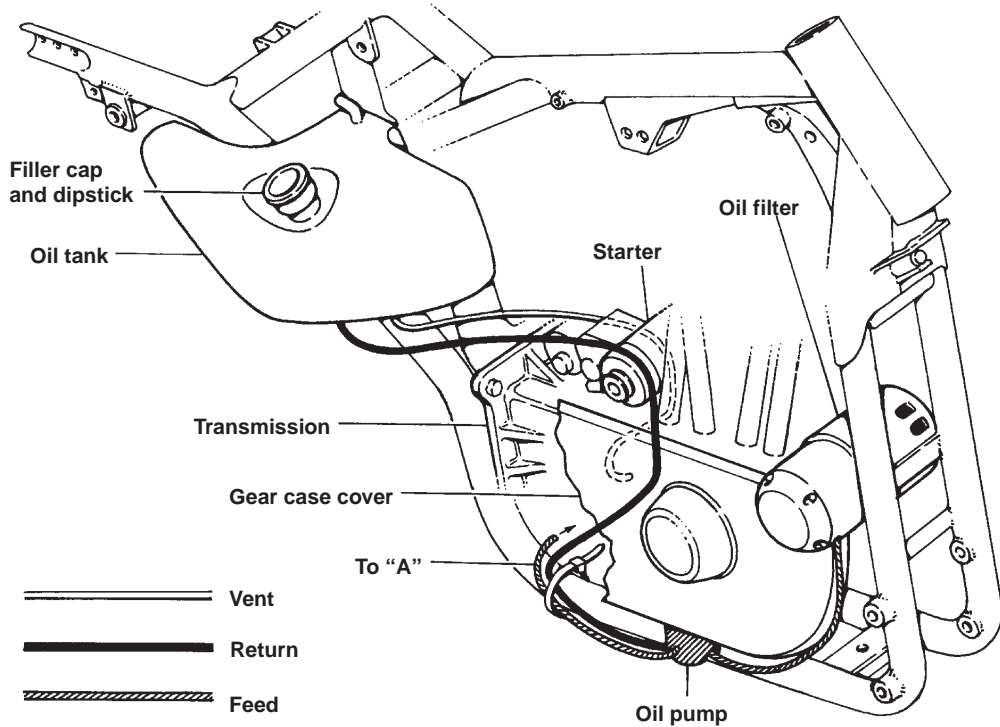

22

LOWER ENGINE MOUNT

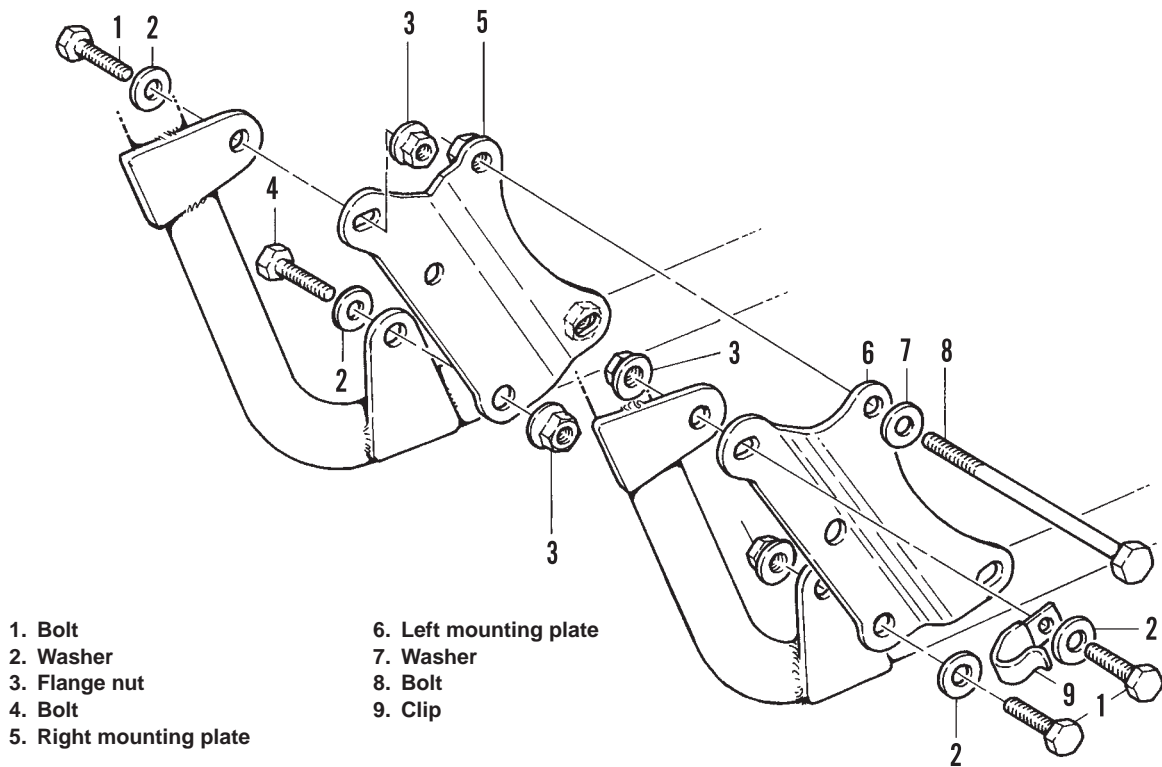

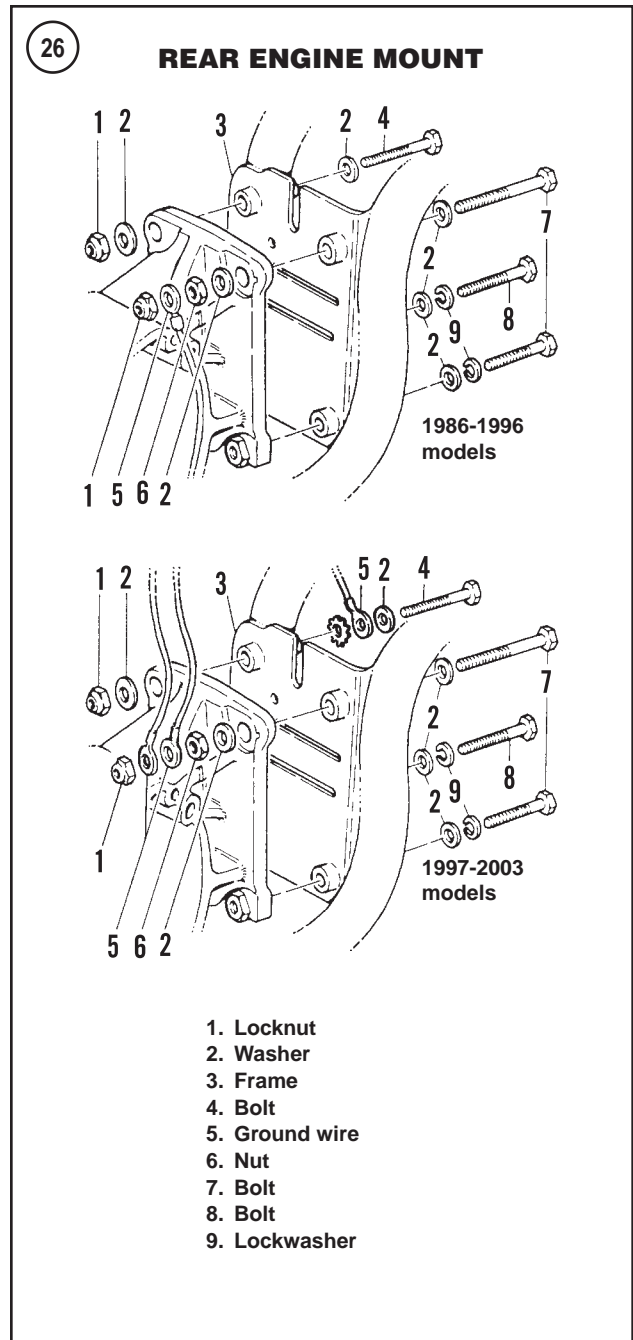

these major components was replaced, a different thickness shim may be required.

- c. Install the top center engine mount onto the engine. Insert the two engine mount bolts through the frame so that the shim does not fall off.
 - d. Place the nut plate into position (**Figure 31**) and thread the engine mount bolts into the nut plate hand tight.
 - e. Install the VOES.
 - f. Tighten the engine bolts to 25-30 ft.-lb. (34-41 N•m).
 - g. Tighten the frame bolts to 30-35 ft.-lb. (41-47 N•m).
14. Install the top front engine mount bracket (**Figure 32**) as follows:
- a. Install the front upper mounting bracket and fasteners. Tighten all of the bolts hand-tight only.
 - b. Tighten the engine bolts to 25-30 ft.-lb. (34-41 N•m).
 - c. Tighten the frame bolts to 30-35 ft.-lb. (41-47 N•m).

CAUTION

*Be sure the oil hoses are properly connected in Step 15. Refer to the **Oil Tank and Oil Lines** in Chapter Four.*

15. On 883C and 1200C models, install the footrest assemblies as described in Chapter Seventeen.

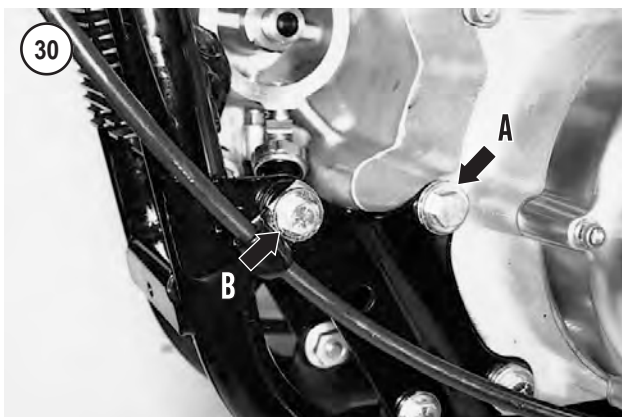
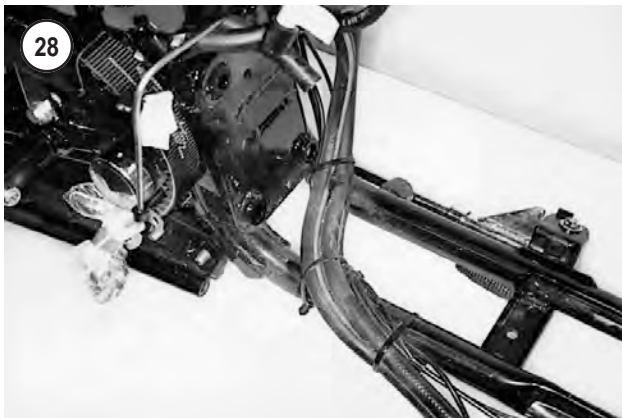

16. Slide a new hose clamp onto the oil feed, return and vent hoses and connect the hoses to the oil tank.

17. Connect the battery ground wire to the crankcase bolt (**Figure 23**).

18. Connect the battery positive cable and the starter relay wire to the starter (Chapter Twelve).

19. Reconnect the regulator/rectifier electrical connector at the alternator stator connector. See **Figure 17** (1986-1993 models) or **Figure 18** (1994-2003 models).

20. Reconnect the ignition timer plate wires at the wiring harness connectors (**Figure 16**, typical).

21. Reconnect the neutral switch electrical connector at the neutral switch (**Figure 15**).

22. Connect the oil pressure switch electrical connector at the oil pressure switch (**Figure 14**).

23. Reconnect the clutch cable at the handlebar. Adjust the clutch as described in Chapter Three.

24. Install the intake manifold as described in Chapter Ten or Chapter Eleven.

25. Install the carburetor and reconnect the throttle and choke cables to the carburetor as described in Chapter Ten or Chapter Eleven. Adjust both cables as described in Chapter Three.

26. Install the choke knob bracket (**Figure 4**).

27. Install the rear chain or drive belt (**Figure 13**) onto the front sprocket.

28. Install the rear sprocket cover as follows:

- a. Install the rear sprocket cover (A, **Figure 11**) together with the rear brake pedal and linkage assembly.
- b. Install the rear sprocket cover mounting bolts and washers; tighten the bolts securely.
- c. Reconnect the brake linkage to the master cylinder (**Figure 12**).
- d. Install the rear master cylinder bolts (B, **Figure 11**) and washers and secure the master cylinder to the sprocket cover.
- e. Secure the brake line with the clip and screw (C, **Figure 11**).

29. Adjust the rear brake pedal as described in Chapter Three.

30. On all models except 1998-2003 1200S models, connect the VOES vacuum hose to the fitting on the carburetor (**Figure 2**) and connect the VOES electrical connector to the ignition module.

31. Reinstall the ignition coil bracket and the throttle cable clip (where equipped).

32. Install the ignition coil as described in Chapter Twelve.

33. Install the hom as described in Chapter Twelve.

34. Reconnect the spark plug wires.

35. Install the air filter backplate (Chapter Ten or Chapter Eleven).

36. Install the exhaust system as described in Chapter Ten or Chapter Eleven.

31

TOP CENTER ENGINE MOUNT

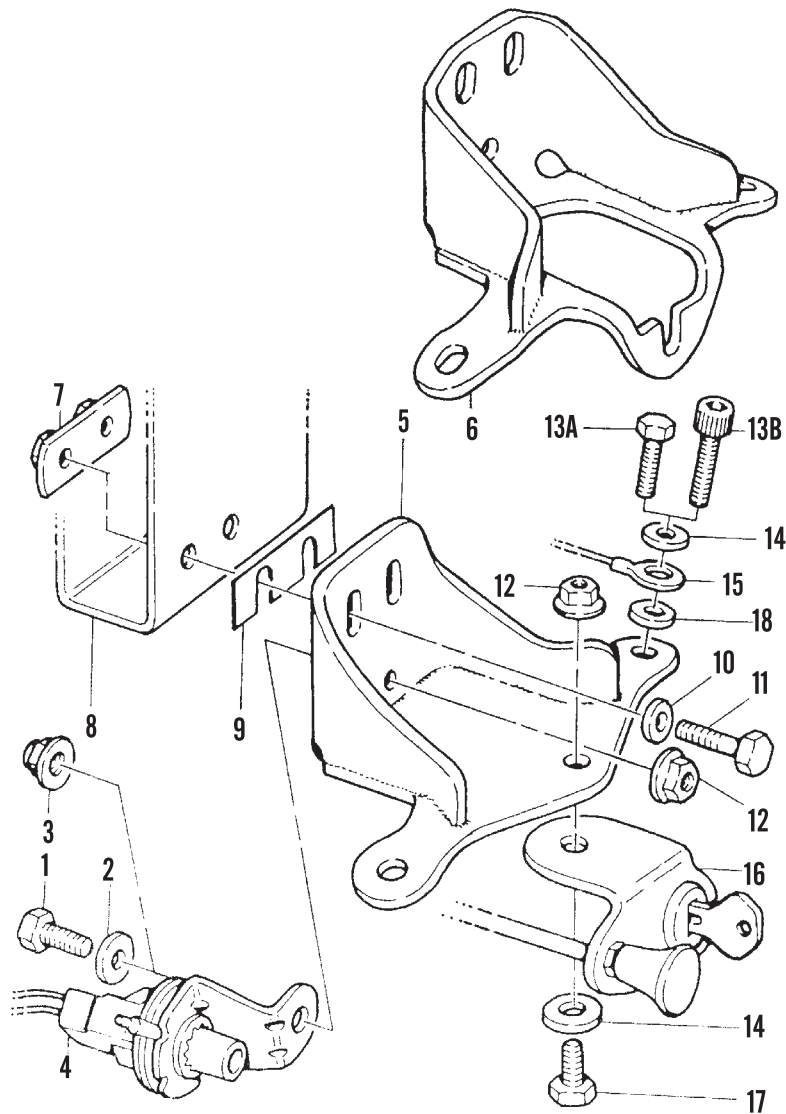

- | | |
|---|---|
| 1. Bolt (1986-1991 models) | 11. Bolt |
| 2. Washer (1986-1991 models) | 12. Locknut |
| 3. Locknut (1992-2003 models) | 13A. Bolt (1986-1991 models) |
| 4. VOES (all models except 1998-2003 1200S models) | 13B. Bolt (1992-2003 models) |
| 5. Top center engine bracket (1991-1994 models) | 14. Lockwasher (1986-1994 models)/ Washer (1995-2003 models) |
| 6. Top center engine bracket (1995-2003 models) | 15. VOES ground wire (1986-1993 models) |
| 7. Nut plate | 16. Ignition bracket (1986-1994 models) |
| 8. Frame | 17. Bolt |
| 9. Shim | 18. Washer (1986-1994 models) |
| 10. Washer | |

32

TOP FRONT ENGINE MOUNT

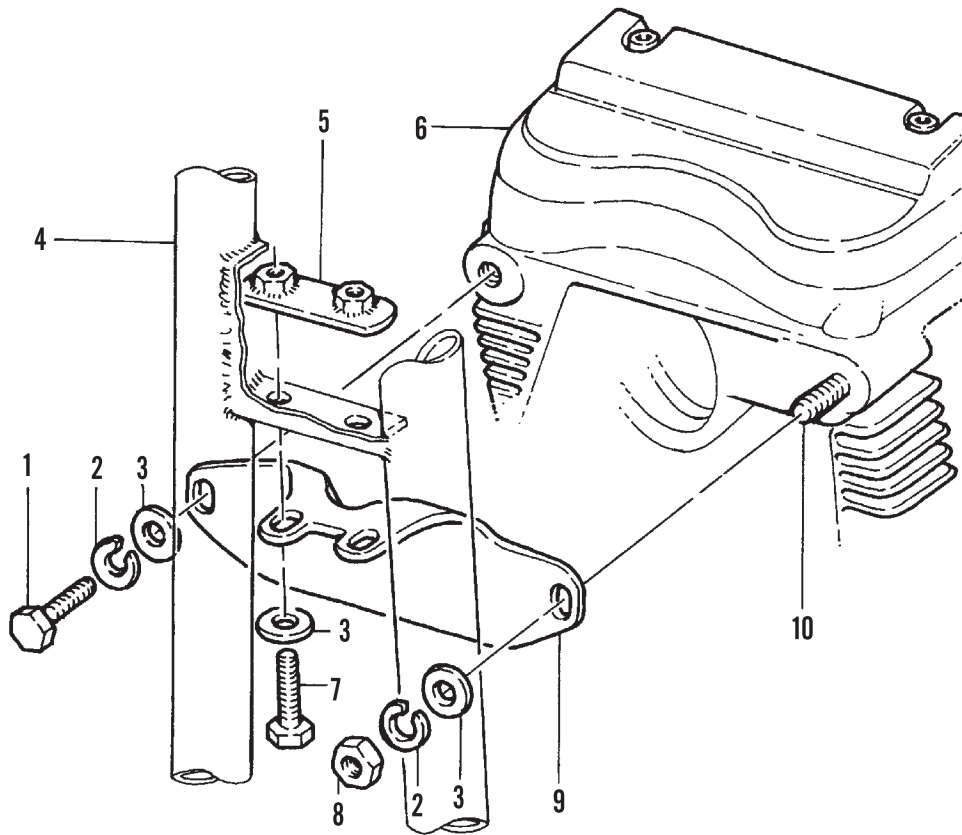

1. Bolt
2. Lockwasher
3. Washer
4. Frame downtube
5. Nut plate
6. Engine
7. Bolt
8. Nut
9. Top front engine bracket
10. Stud

5

37. Install the fuel tank as described in Chapter Ten or Chapter Eleven. Secure the fuel hose with new hose clamps, if necessary.

38. Clean the battery and check the electrolyte level as described in Chapter Twelve. The battery should be in good condition and fully charged prior to installing it in the frame.

39. Install the battery tray and battery (Chapter Twelve).

40. Install a new oil filter and refill the engine oil (Chapter Three).

41. Refill the transmission oil (Chapter Three).

42. Reconnect the positive battery cable, then the negative cable (Chapter Twelve).

CAUTION

*Check the battery breather tube routing to prevent battery mist from damaging exposed parts. Refer to **Battery** in Chapter Twelve.*

43. Adjust the drive chain or belt (Chapter Three).

44. Install the seat and seat bolt. Tighten the bolt securely.

45. Before starting the engine, perform the following:

- a. Recheck the engine tank oil level (Chapter Three).

- b. Check the oil tank hoses for leaks.
 - c. Recheck the transmission oil level. (Chapter Three).
 - d. Check that the throttle moves smoothly and snaps back when released.
 - e. Check the fuel tank for an adequate supply of gasoline. If the motorcycle has been sitting for an extended period, drain the tank and fill with fresh gasoline.
 - f. Turn off the fuel valve and check for leaks. Turn the fuel valve on.
 - g. Wipe off the exhaust pipes with a clean rag to remove as much oil and grease residue as possible to prevent the pipes from smoking when they become hot.
46. Start the engine and allow it to idle with the transmission in neutral. Note the following:
- a. Listen carefully for rattles or other abnormal sounds. These may indicate loose brackets or fasteners.
 - b. When the engine reaches normal operating temperature, shut it off.
 - c. Check the engine oil level (Chapter Three).
 - d. Check the transmission oil level (Chapter Three).

CAUTION

Failure to follow proper break-in procedures will reduce engine longevity and performance.

47. If new parts were installed, the engine should be broken in as described in this chapter.
48. Before riding the motorcycle, perform the *Routine Safety Checks* in Chapter Three.

VALVE TAPPETS AND GUIDES (1986-1990 MODELS)

Refer to **Figure 33**. During engine operation, the tappets are pumped full of engine oil, thus taking up all play in the valve train. When the engine is not running, the tappets may leak down after a period of time if some of the oil drains out. When the engine is started, the tappets click momentarily until they completely refill with oil. The tappets are working properly if they stop clicking after the engine runs for a few minutes. If the clicking persists, there may be a problem.

Removal

Mark all parts so that they can be returned to their original positions.

1. Remove all dirt from the tappet area.
2. Remove the pushrods and covers as described in Chapter Four.

NOTE

*It is not necessary to remove the cylinder and cylinder head as shown in **Figure 34** to remove the valve tappets.*

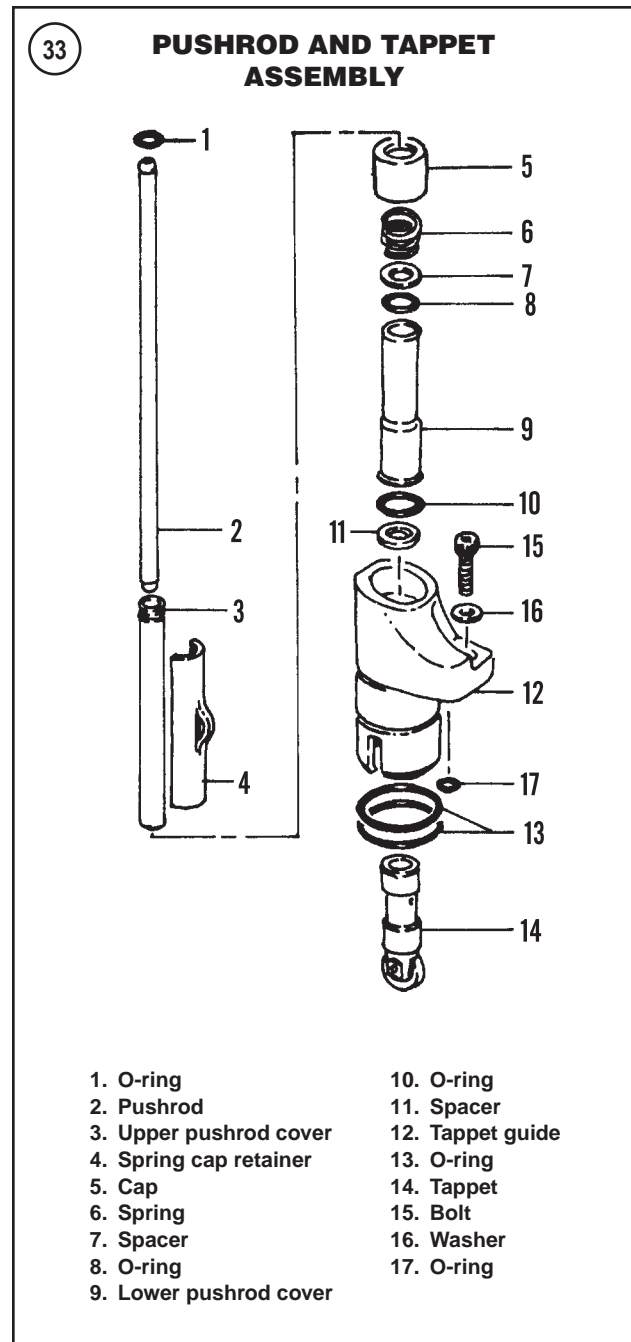

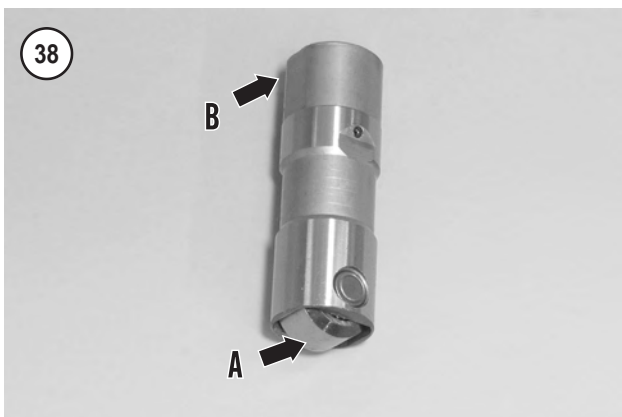
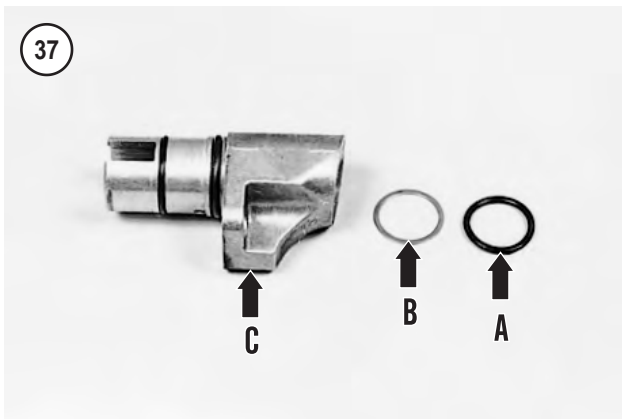
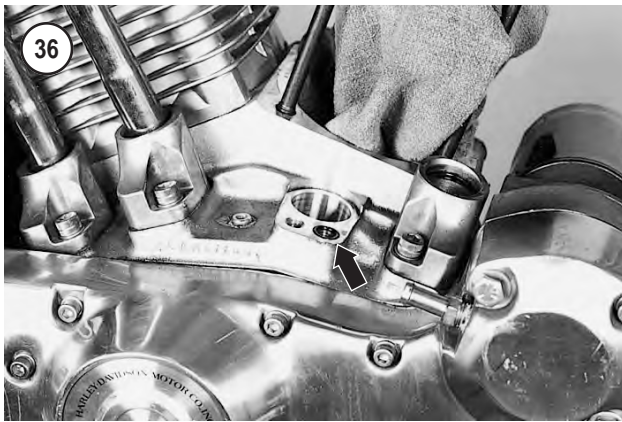

5

3. Remove the tappet guide bolts (Figure 34).
4. Rotate front tappet guides clockwise or rear tappet guides counterclockwise and remove the guides).

NOTE

If the tappet is tight in the guide, tap it lightly with a rubber-faced hammer and remove it.

5. Remove the tappet (Figure 35) from the guide. Store the tappets in a container of oil so they can be installed in their original position. Cover the storage container so debris cannot contaminate the oil.
6. Discard the crankcase O-ring (Figure 36).

Cleaning and Inspection

CAUTION

Tappets must be stored and handled carefully to prevent contamination from debris. When storing tappets, leave them in the container of engine oil they were placed in during removal. When measuring or inspecting tappets, place them on a clean, lint-free cloth.

NOTE

The tappet is available only as a unit assembly.

1. Remove the O-ring (A, Figure 37) and spacer(B) from the tappet guide (C).
2. Except for the roller/tappet assembly, clean all parts in solvent and allow to dry thoroughly.
3. Check the tappet rollers (A, Figure 38) for pitting, scoring, galling or excessive wear. If the rollers are worn excessively, check the mating cam lobes for the same wear conditions. The cam lobes can be observed through the tappet guide hole in the crankcase. Replace the cam, if necessary, as described in this section.
4. Inspect the tappet socket (Figure 39, typical) for pitting, scoring, galling or excessive wear.
5. Determine valve tappet guide clearance as follows:



- a. Measure and record the tappet guide inner diameter (**Figure 40**).
- b. Measure and record the valve tappet outside diameter (**B, Figure 38**).
- c. Subtract the measurement made in substep b from the measurement made in substep a. The difference is the tappet-to-guide clearance. See specifications in **Table 1** for correct clearance. Replace any guide or tappet not within tolerances.

6. Check the roller end clearance by grasping the tappet assembly in one hand and attempting to move the roller back and forth. **Table 1** lists wear specifications. If the end clearance is excessive, replace the tappet assembly.

Installation

1. Soak the tappet assembly in clean engine oil before installation.
2. Install new O-rings onto the tappet guide.
3. Insert the spacer (**B, Figure 37**) and O-ring (**A**) into the tappet guide (**C**). Make sure the O-ring seats completely in the tappet guide.
4. Install a new crankcase O-ring (**Figure 36**).
5. Insert the tappet into the guide (**Figure 35**).

CAUTION

If the tappet is not installed correctly, the roller and cam may be damaged when the assembly is installed in Step 6.

6. Perform the following:
 - a. Align the tappet guide with the crankcase holes.
 - b. Hold the tappet so that it is all the way up in the guide.
 - c. Install the tappet guide and tappet.
 - d. Install the tappet bolts (**Figure 34**) and tighten to 96-168 in.-lb. (11-19 N•m)
7. Install the pushrods and covers as described in Chapter Four.

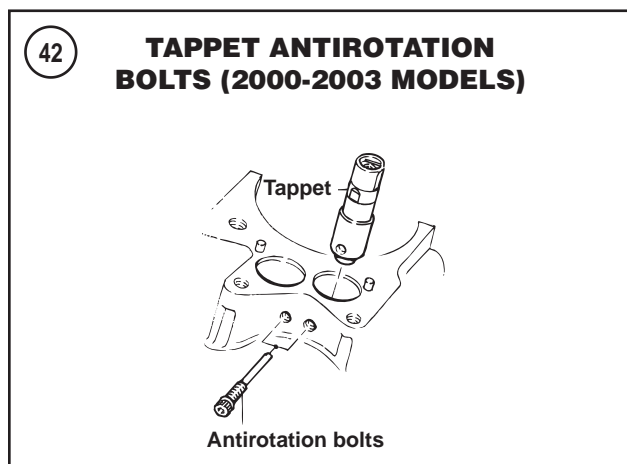
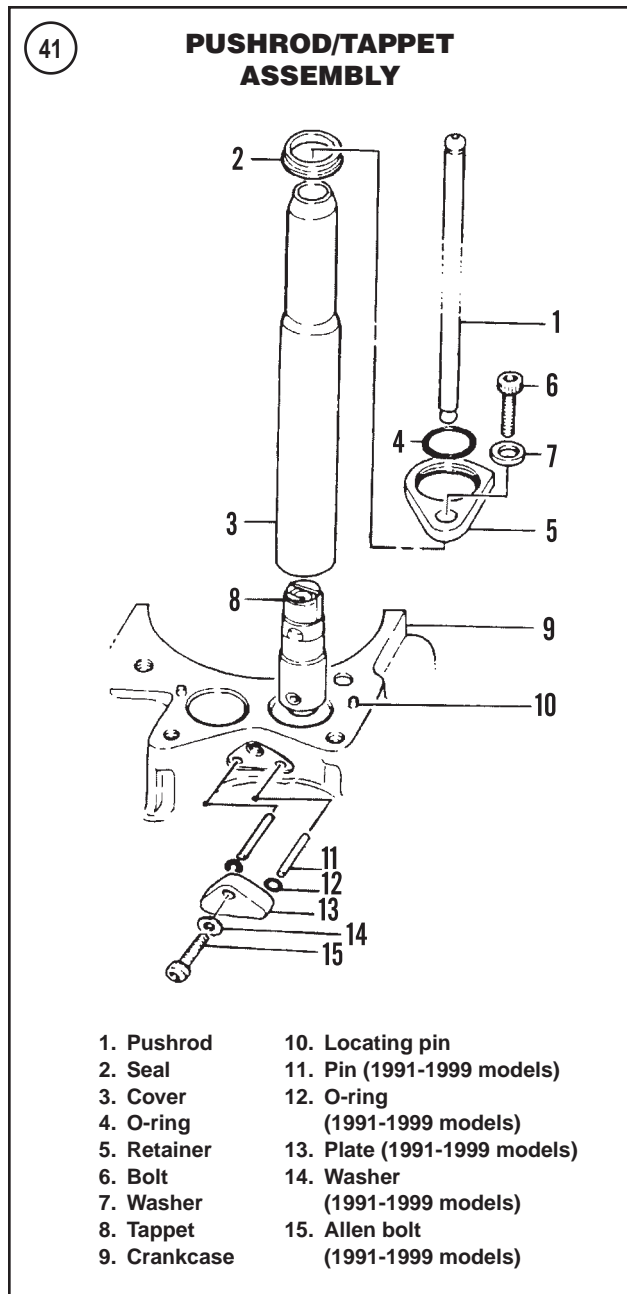



VALVE TAPPETS (1991-2003 MODELS)

Refer to **Figure 41** and **Figure 42** for an exploded view of the valve tappet, pushrod and cover assembly. During engine operation, the tappets are pumped full of engine oil taking up the play in the valve train. When the engine is not running, the tappets may leak down after a period of time if some of the oil drains out. When the engine is started, the tappets click momentarily until they completely refill with oil. The tappets are working properly if they stop clicking after the engine runs for a few minutes. If the clicking persists, there may be a problem in the tappet(s).

Removal

Refer to **Figure 41** and **Figure 42**.

1. Remove the pushrods and covers as described in Chapter Four.
- 2A. On 1991-1999 models, perform the following:
 - a. Remove the lifter plate bolt and washer and remove the plate (**Figure 43**).
 - b. Remove the tappet pin and O-ring (**Figure 44**).
- 2B. On 2000-2003 models, remove the anti-rotation bolts (**Figure 42**).
3. Remove the tappet (**Figure 45**) from the crankcase bore. Store the tappets in a container of oil so they can be installed in their original tappet bores. Cover the tappet storage container so dirt and debris cannot contaminate the oil.
4. Repeat for each tappet.
5. Discard all O-rings.

Cleaning and Inspection

CAUTION

Tappets must be stored and handled carefully to prevent contamination from dirt or debris. When storing tappets, leave them in the container of engine oil they were placed in during removal. When measuring or inspecting tappets, place them on a clean, lint-free cloth.

NOTE

The tappet is available only as a unit assembly.

1. Clean the pushrod covers in solvent and dry with compressed air. Do not clean the tappets in solvent or with any other type of cleaner. Leave the tappets in the container of oil except when inspecting and installing them.
2. Check the tappet rollers (**Figure 46**) for pitting, scoring, galling or excessive wear. If the rollers are worn excessively, check the lobes on the cam gears for the same conditions. The gear lobes on the cam gears can be observed through the tappet guide hole in the crankcase. Replace the cam, if necessary, as described in *Gearcase Cover and Timing Gears* in this chapter.

3. Inspect the tappet socket (**Figure 47**) for pitting, scoring, galling or excessive wear.
4. Determine the valve guide inner diameter as follows:
 - a. Measure and record the valve tappet bore inner diameter.
 - b. Measure and record the valve tappet outer diameter (**Figure 48**).
 - c. Subtract the measurement recorded in Substep a. from the measurement recorded in Substep b. The difference is the tappet-to-guide clearance. Refer to **Table 1** for specifications. Correct out of specification tappet-to-guide clearances by replacing tappets or the crankcase.
5. Measure tappet roller end clearance. If end clearance is worn to the service limit specification in **Table 1**, replace the tappet.
6. Measure tappet roller fit on pin. If clearance meets or exceeds the service limit in **Table 1**, replace the tappet.

Installation

1. Rotate the engine counterclockwise so that the cam lobes for the tappets being installed are positioned with their base lobes facing up.
2. Soak each tappet in clean engine oil prior to installation. Make sure the roller needles (**Figure 46**) are well lubricated. This step will ensure smooth tappet operation and lubrication during initial engine start-up.
3. Install the tappet (**Figure 45**) into its original crankcase tappet bore; refer to your identification notes made during removal. Align the tappet so that the flats on the tappet face the front and rear of the engine; see **Figure 49**.
- 4A. On 1991-1999 models, perform the following:
 - a. Insert the pins (**Figure 44**) through the crankcase holes.

NOTE

If the pins cannot be installed into the tappet body, the tappet is installed incorrectly.

- b. Place a new O-ring over the end of the pin as shown in **Figure 50**.
 - c. Install the plate (**Figure 43**), washer and screw. Tighten the tappet plate screw to 80-110 in.-lb. (9-12 N·m).
- 4B. On 2000-2003 models, secure the tappets in place with the anti-rotation bolts (**Figure 42**). Tighten the bolts to 55-65 in.-lb. (6-7 N·m).
5. Install the pushrods and pushrod covers as described in Chapter Four.

GEARCASE COVER AND TIMING GEARS

The gearcase assembly consists of the following components (**Figure 51**):

1. Four cam gears.

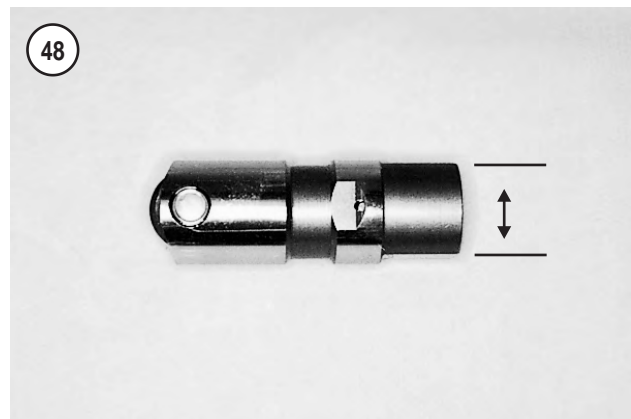

51

CAM GEARS (1986-1990 MODELS)

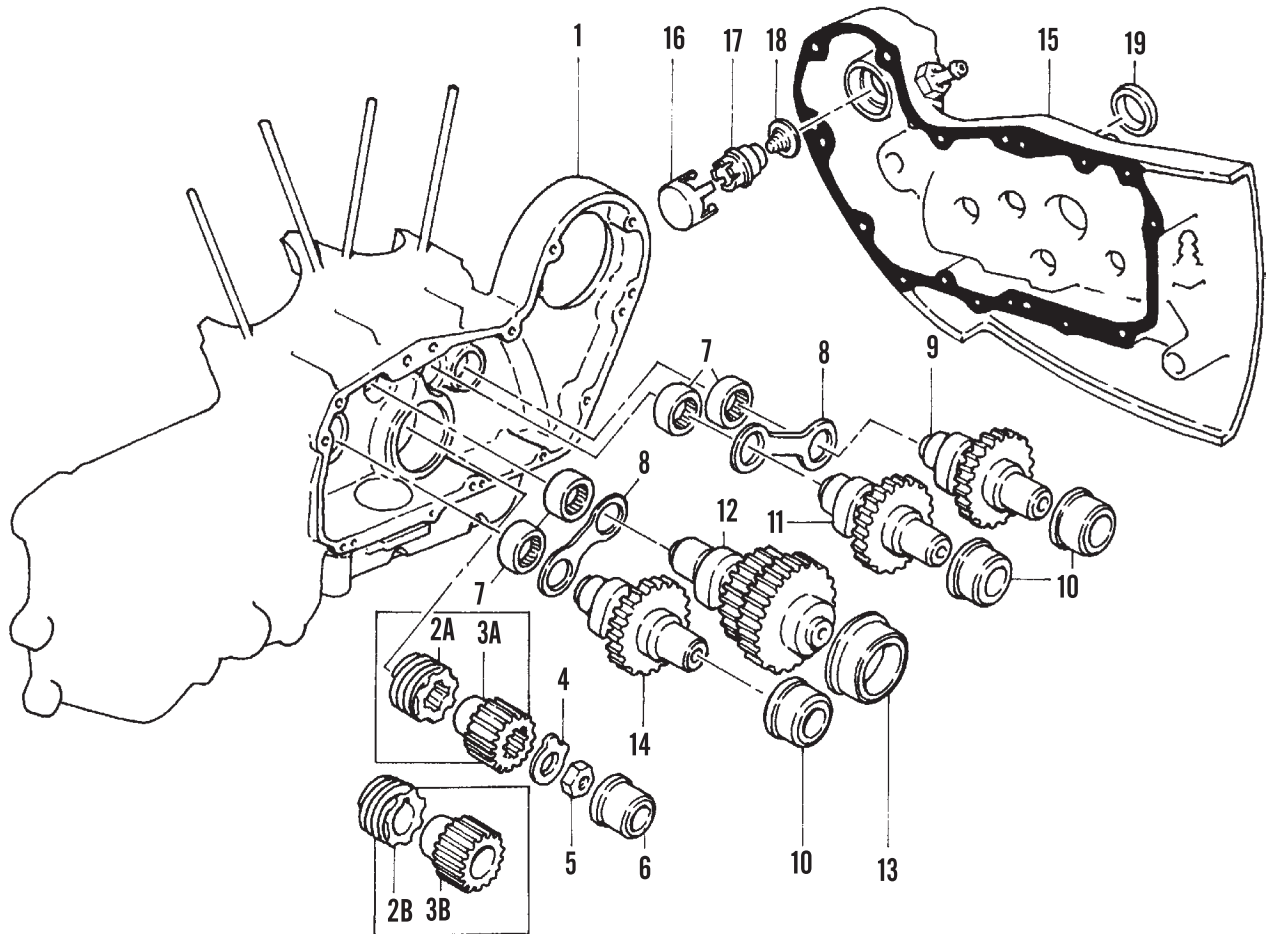

- 1. Crankcase half
- 2A. Oil pump drive gear (1986-1987 models)
- 2B. Oil pump drive gear (1988-1990 models)
- 3A. Pinion gear (1986-1987 models)
- 3B. Pinion gear (1988-1990 models)
- 4. Lockwasher
- 5. Nut
- 6. Bushing
- 7. Needle bearing
- 8. Cam gear guide plate
- 9. Front cylinder exhaust cam gear
- 10. Bushing
- 11. Front cylinder intake cam gear
- 12. Rear cylinder intake cam gear
- 13. Bushing
- 14. Rear cylinder exhaust cam gear
- 15. Gearcase cover
- 16. Breather baffle
- 17. Breather tube
- 18. Diaphragm valve
- 19. Seal

52

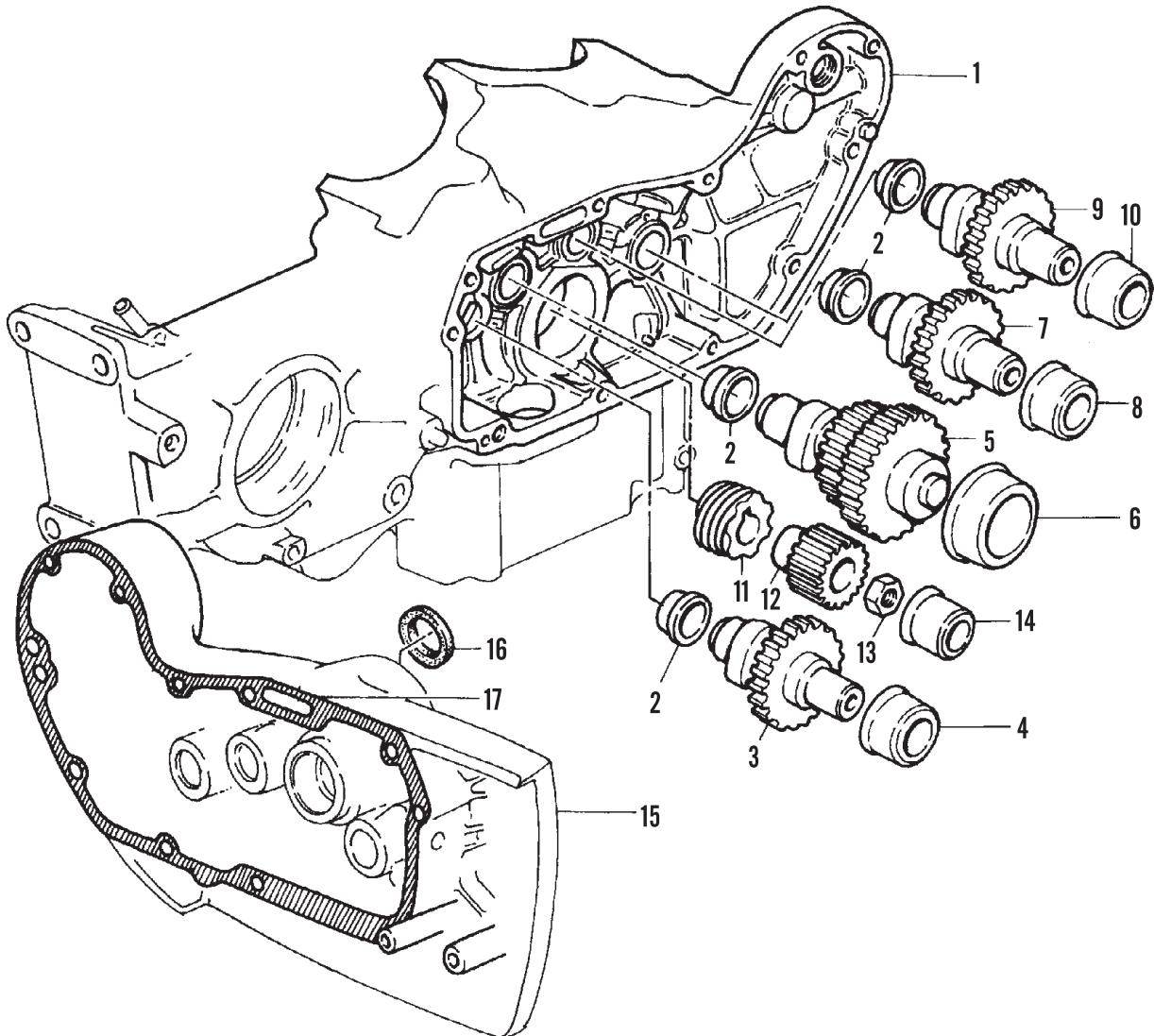
CAM GEARS (1991-2003 MODELS)

1. Right crankcase half
2. Cam gear bushing
3. Rear exhaust cam gear
4. Rear exhaust cam gear bushing
5. Rear intake cam gear
6. Rear intake cam gear bushing
7. Front intake cam gear
8. Front intake cam gear bushing
9. Front exhaust cam gear

10. Front exhaust cam gear bushing
11. Oil pump drive gear
12. Pinion gear
13. Nut
14. Pinion gear bushing
15. Gearcase cover
16. Seal
17. Gasket

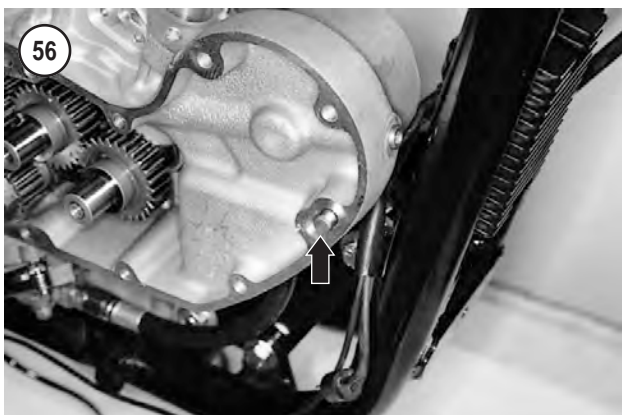
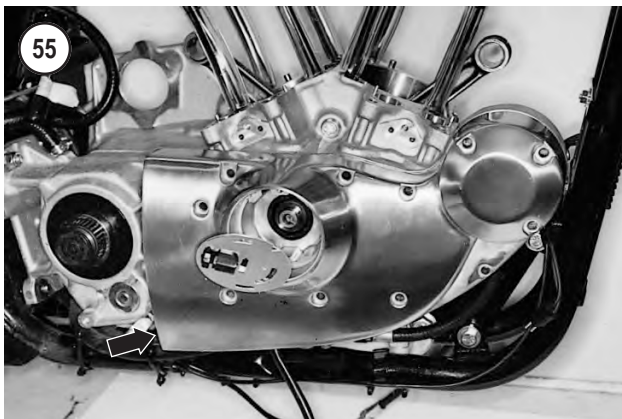

2. Four cam gear bushings installed in the right crankcase half.
3. Four cam gear bushings installed in the gearcase cover.
4. Pinion gear.
5. Oil pump drive gear.
6. Oil seal installed in gearcase cover.

Removal

Refer to **Figure 51** or **Figure 52**.

1. Remove the exhaust system as described in Chapter Ten or Chapter Eleven.
2. Remove the right footpeg assembly as described in Chapter Seventeen.
3. Remove the pushrods and valve tappets as described in this chapter.
4. Before removing the gearcase cover, check the cam gear end play as follows:
 - a. Rotate the engine counterclockwise so that the cam being checked has its lobe facing up.
 - b. Pry the cam gear toward the gearcase cover with a wide-blade screwdriver.
 - c. Measure the gap between the cam gear shaft thrust face and the bushing in the crankcase with a feeler gauge (**Figure 53**). This gap is cam gear end play. Write down the end play measurement.
 - d. Repeat for each cam gear.
 - e. If the end clearance is incorrect (**Table 1**), replace the bushing and/or cam gear as described in this section.
5. Remove the ignition system sensor plate and rotor as described in Chapter Twelve.
6. Place an empty oil pan underneath the crankcase cover.
7. Disconnect and plug the vent oil line (**Figure 54**) from the crankcase cover.

NOTE

The gearcase cover is retained by different length screws. Create a drawing on cardboard in the shape of the gearcase, then punch each screw through the cardboard at its location.

8. Remove the gearcase cover mounting screws.
9. Remove the gearcase cover (**Figure 55**) from the engine. If the cover is stuck in place, tap the cover lightly with a soft-faced hammer to free it from the gasket or sealer.
10. Remove and discard the gasket.
11. If necessary, remove the dowels (**Figure 56**).

NOTE

After removing a cam gear, label and then place it in a container so that it can be reinstalled in its original position.

12. Remove and identify each cam gear:

- a. Rear exhaust cam gear (A, **Figure 57**).
- b. Rear intake cam gear (B, **Figure 57**).
- c. Front intake cam gear (C, **Figure 57**).
- d. Front exhaust cam gear (D, **Figure 57**).

13. On 1986-1990 models, remove the cam gear guide plates (8, **Figure 51**).

NOTE

Loctite 272 was originally applied to the pinion gear nut.

14. If available, install a pinion gear locking tool (part No. part No. 2234) (A, **Figure 58**).

15. On 1986-1987 models, pry the lockwasher tab away from the pinion gear nut.

16. Loosen, then remove the pinion gear nut (B, **Figure 58**). On 1986-1987 models, remove the lockwasher.

17. Slide the pinion gear (C, **Figure 58**) and oil pump drive gear (**Figure 59**) off the pinion shaft. On 1998-2003 models, do not lose the Woodruff key in the pinion shaft.

Inspection

1. Clean the gearcase compartment, cover and components with solvent. Blow out all oil passages with compressed air. Make sure all traces of gasket compound are removed from the gasket mating surfaces.
2. Check the pinion gear and cam gear bushings (**Figure 60** in the gearcase cover for grooving, pitting or other wear). If the bushings are worn, replace them.
3. Inspect the cam gears (**Figure 61**) for cracks, deep scoring or excessive wear. The gears will show signs of pattern polish but there should be no other damage.

NOTE

Cam gears are available only as complete sets.

4. On 1986-1990 models, inspect the cam gear plates (**Figure 62**) for damage or excessive wear. Replace if necessary.
5. On 1986-1990 models, refer to **Figure 51** and inspect the breather valve as follows:

- a. Detach the breather assembly from the crankcase cover.
- b. Clean the components in solvent.
- c. Blow out the bleed passage in the crankcase cover with compressed air.
- d. Replace the breather valve if damaged or deteriorated.
- e. Replace the baffle and tube if cracked or damaged.
- f. Insert the diaphragm valve into the breather tube.
- g. Install the breather tube assembly into the cover.
- h. Push the breather baffle into the tube assembly until the baffle fingers engage the breather tube ring.

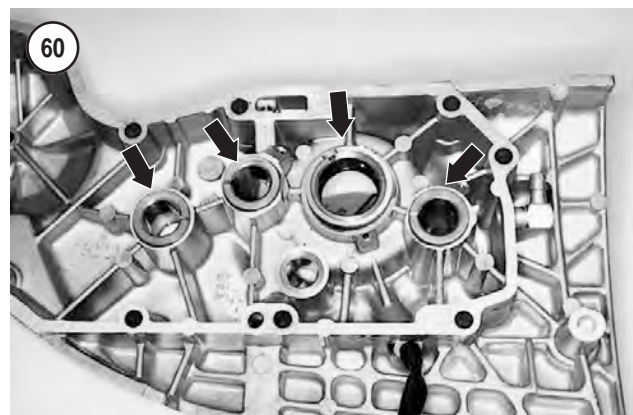
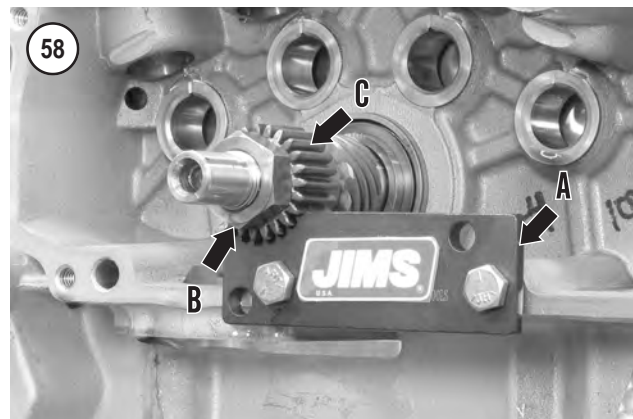
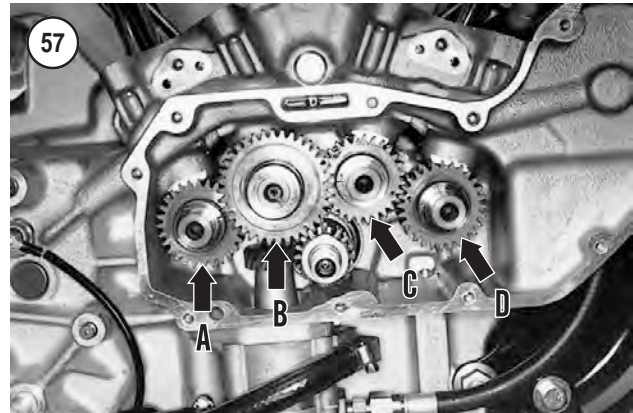

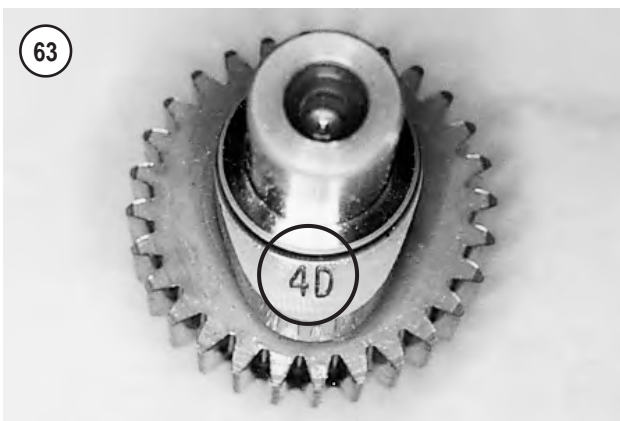

Cam Gear Identification

The cam gear group consists of the following:

1. Rear exhaust cam gear (A, **Figure 57**).
2. Rear intake cam gear (B, **Figure 57**).
3. Front intake cam gear (C, **Figure 57**).
4. Front exhaust cam gear (D, **Figure 57**).
5. Pinion gear (C, **Figure 58**).

The cam lobes are stamped with a number (1, 2, 3 or 4) and a letter ("D" or "W"), see **Figure 63**. The number identifies the location in the engine:

1. 1–rear exhaust cam gear.
2. 2–rear intake cam gear.
3. 3–front intake cam gear.
4. 4–front exhaust cam gear.

The letter identifies engine application as follows:

T–1986-1987 models.

C–1988-1990 models.

D–All 1991-2003 models except 1998-2003 1200S models.

W–1998-2003 1200S models.

Measuring Cam Gear and Pinion Gear Bushing Wear

NOTE

On 1986-1990 models a needle bearing supports the inner end of each cam gear in the crankcase. Measure the cam gear shaft diameter to determine shaft wear. Replace the bearing if damaged.

On 1991-2003 models the cam gears and outer end of the pinion gear are supported by bushings in the gearcase cover and crankcase. Excessive cam gear and pinion gear bushing clearance can cause excessive cam gear backlash.

1. Measure the cam/pinion gear outer diameter. Write down the outer diameter measurement.
2. Measure the corresponding bushing inner diameter. Write down the inner diameter measurement.
3. Subtract the measurement made in Step 2 from the measurement made in Step 1. The difference is the cam gear shaft bushing clearance. See **Table 1** for the cam and pinion gear clearances. If clearance is excessive, replace the bushing as described in this section.

Bushing Removal

Gearcase cover (**Figure 60**) and crankcase (**Figure 64**) bushing replacement requires a number of special tools, including reamers for reaming the new bushings. Incorrect bushing installation will cause increased gear noise and premature wear. Refer all bushing service to a dealership.

Gearcase Cover Oil Seal Replacement

1. Inspect the oil seal (**Figure 65**) for excessive wear, hardness, cracks or other damage.
2. Remove the oil seal using a seal puller or similar tool.
3. Pack the lip of the new oil seal with a waterproof bearing grease prior to installation.
4. Press in the oil seal (**Figure 65**) so that the manufacturer's name and size code faces out.

Installation

1. Apply engine oil to the pinion shaft, oil pump drive gear and pinion shaft gear.
2. Clean the pinion shaft threads and the pinion shaft nut of all threadlock residue.

NOTE

On 1986 and 1987 models, the oil pump drive gear, pinion gear and shaft are splined. On 1988-2003 models, a Woodruff key (**Figure 66**) in the shaft secures the oil pump drive gear and pinion gear.

3. On 1988-2003 models, install the oil pump drive gear Woodruff key (**Figure 66**), if removed.
4. Slide the oil pump drive gear (**Figure 59**) onto the pinion shaft.
- 5A. On 1986-1987 models, install the pinion gear on the pinion shaft while aligning the timing marks on the gear and shaft.
- 5B. On 1988-2003 models, align the pinion gear timing mark (A, **Figure 67**) with the center of the pinion shaft keyway (B) and install the gear.
6. If available, install a pinion gear locking tool (part No. 2234) (A, **Figure 58**).
- 7A. On 1986-1987 models, install the pinion shaft lockwasher and nut. Tighten the nut to 35-45 ft. lb. (47-61 N•m). Bend the lockwasher tabs to secure the nut.
- 7B. On 1988-2003 models, apply threadlock (Loctite 272 or equivalent) to the pinion shaft nut (B, **Figure 58**) prior to installation. Install the nut and tighten to 35-45 ft. lb. (47-61 N•m).
8. On 1986-1990 models, install both cam gear plates in their gearcase recesses. Position the cam gear plates so the beveled side of the holes faces toward the cams.
9. Identify the cam gears as described in this section.
10. Apply engine oil to the bearings, if so equipped, bushings, gears and gear shafts prior to installation.
11. Align the cam gear timing marks as shown in **Figure 68**, install the cam gears in the following order:
 - a. Rear exhaust cam gear (A, **Figure 69**).
 - b. Front intake cam gear (B, **Figure 69**).
 - c. Rear intake cam gear (**Figure 70**).
 - d. Front exhaust cam gear (**Figure 71**).
 - e. Double check that all of the cam gear timing marks are properly aligned (**Figure 68**).

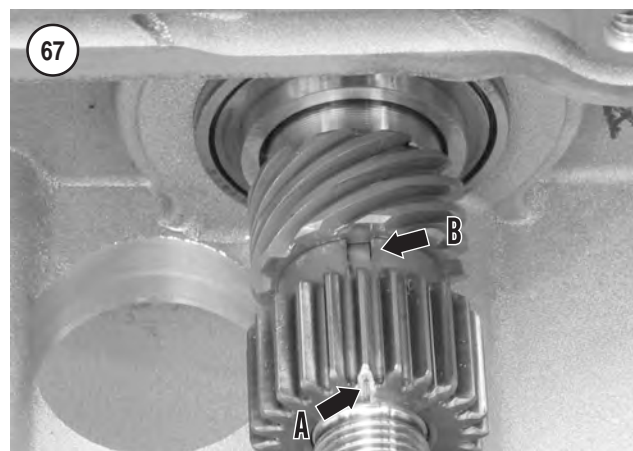

12. Install the dowel pins (**Figure 56**), if removed.
13. Install a new gearcase cover gasket.
14. Install the gearcase cover (**Figure 55**).
15. Install the gearcase cover screws into their correct mounting positions. Tighten the screws fingertight at first, then tighten in a crisscross pattern to 80-110 in.-lb. (9-12 N•m).
16. Check the cam gear end play for each cam gear as described in *Removal* in this section.

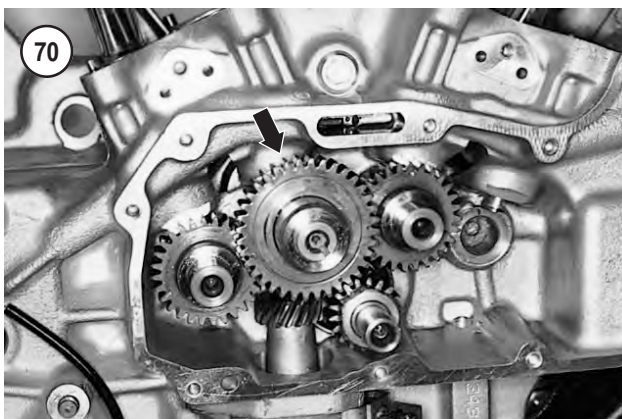
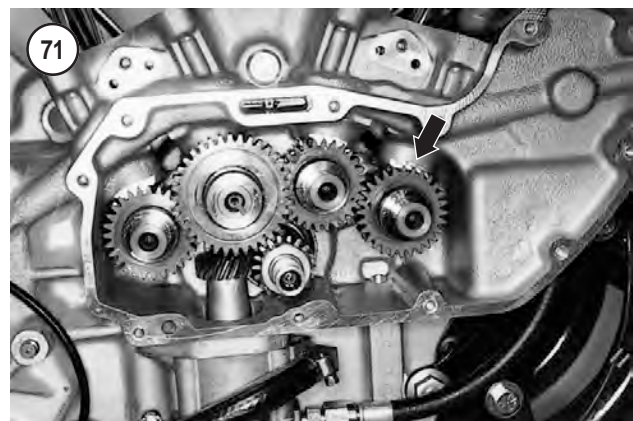
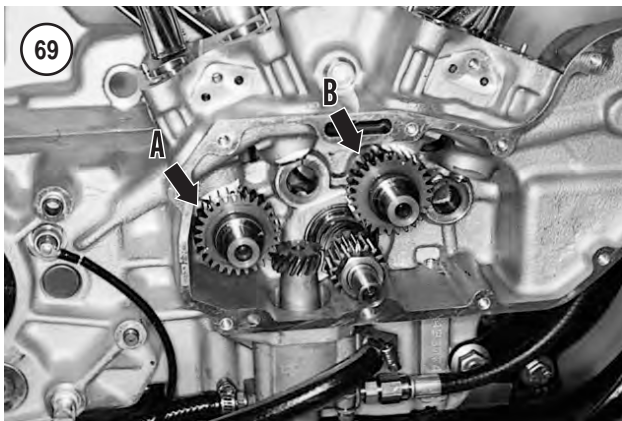
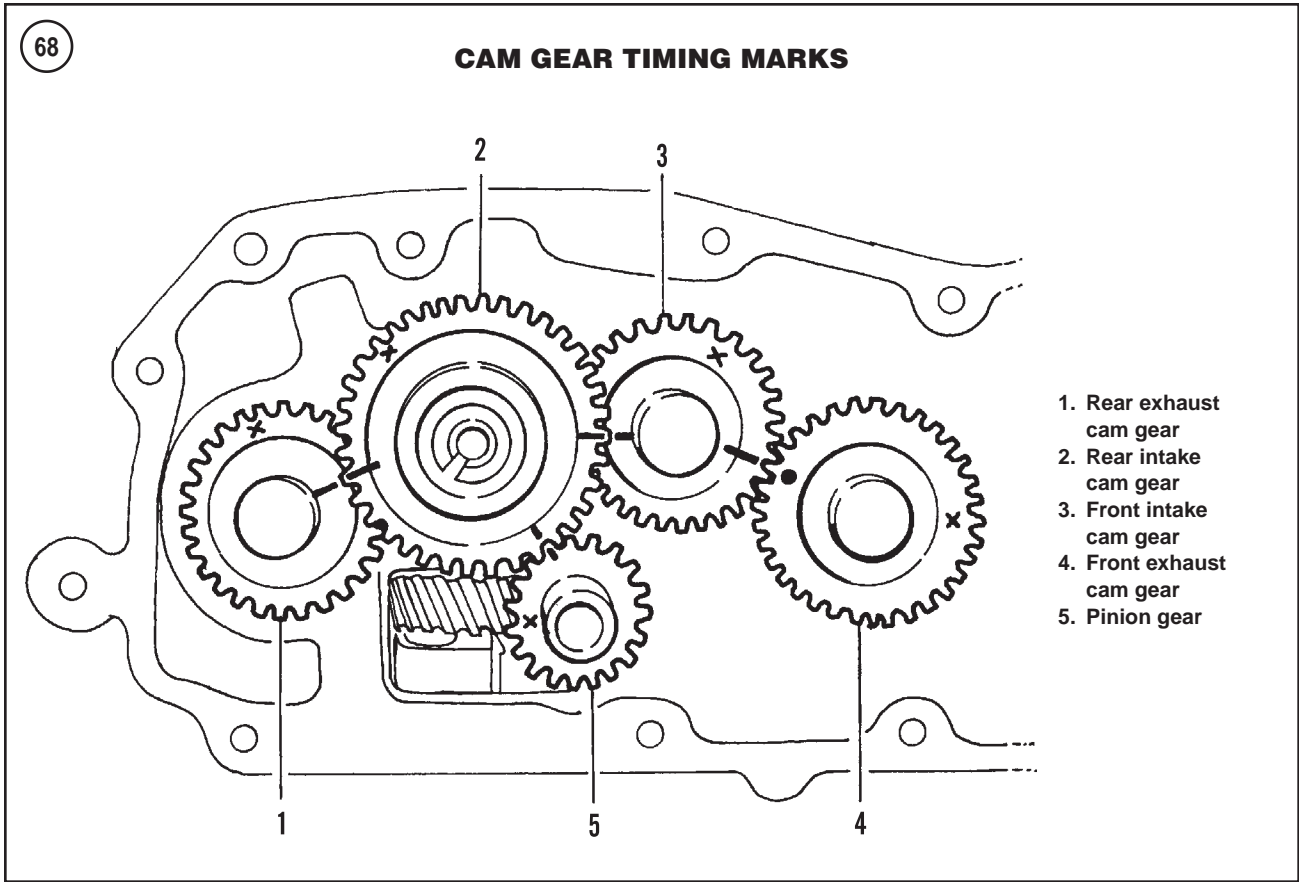

17. Install the valve tappets as described in this chapter.
18. Install the footpeg assembly as described in Chapter Seventeen.
19. Install the exhaust system as described in Chapter Ten or Chapter Eleven.

OIL PUMP (1986-1990 MODELS)

The oil pump is mounted underneath the front of the engine and can be removed with the engine installed in the frame and without removing the gearcase cover.

The oil pump consists of two sections: a feed pump, which supplies oil under pressure to the engine components

and a scavenger pump, which returns oil to the oil tank from the engine.

Removal/Installation

The gearcase cover is shown removed in this procedure for clarity.

1. Place a drip pan underneath the engine.
2. Drain the engine oil tank (Chapter Three).
3. Disconnect the oil lines from the pump (**Figure 72**). Plug the lines to prevent leaks and contamination.
4. Unscrew the bolts (**Figure 73**) that attach the pump to the bottom of the crankcase and remove the pump.
5. Install by reversing these steps, noting the following:
 - a. Clean the crankcase oil pump machined surface (**Figure 74**) of all gasket residue.
 - b. Install a new oil pump gasket.
 - c. Install the bolts (**Figure 73**) and tighten them to 90-110 in.-lb. (10-12 N•m).
6. After installing the oil pump, refill the engine oil and prime the pump as described in *Periodic Lubrication* in Chapter Three.

Disassembly

Refer to **Figure 75**.

1. Remove the oil pump bolts.
2. Remove the cover (**Figure 76**) from the pump body and remove the O-ring (**Figure 77**) from the groove in the cover.
3. Remove the outer (**Figure 78**) and inner (**Figure 79**) feed gerotor set from the shaft. Pull the pin (**Figure 80**) out of the shaft.
4. Remove the outer plate (**Figure 81**), spring washer (**Figure 82**) and the inner plate (**Figure 83**).
5. Remove the outer scavenger gerotor (**Figure 84**).
6. Remove the circlip (**Figure 85**) from the gear shaft.
7. Remove the scavenger inner gerotor (**Figure 86**).
8. Remove the pin (**Figure 87**) from the shaft and remove the gearshaft (**Figure 88**) from the pump body.

Cleaning/Inspection

Refer to **Figure 75**. Replace components not within specification as noted in **Table 1**.

1. Clean all of the parts with solvent and blow dry with compressed air. Blow out all of the ports and passages to ensure no sludge or solvent remains.
2. Replace deformed or damaged O-rings .
3. If the outer plate seal (**Figure 89**) is worn or damaged, carefully pry it out of the outer plate. Tap a new seal in place.
4. Inspect the spring washer (**Figure 90**) for damage and replace it if any of the fingers are broken.
5. Check the gerotor sets (**Figure 91**) for scoring and damage. Assemble the inner and outer rotors of each set. See

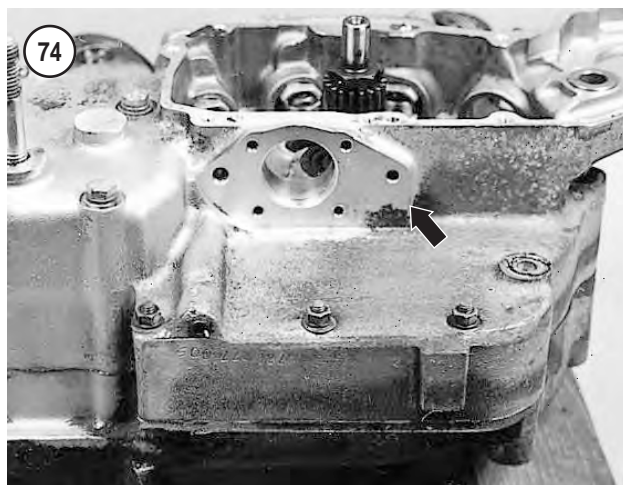
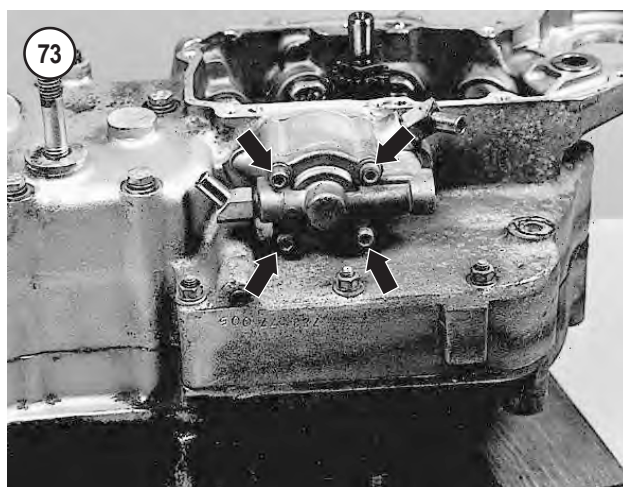
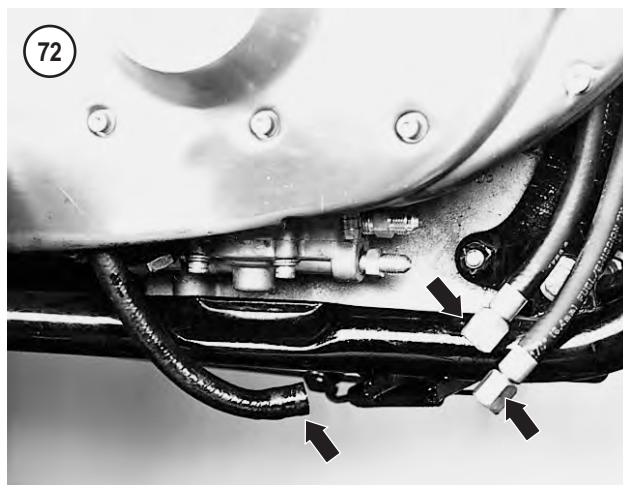
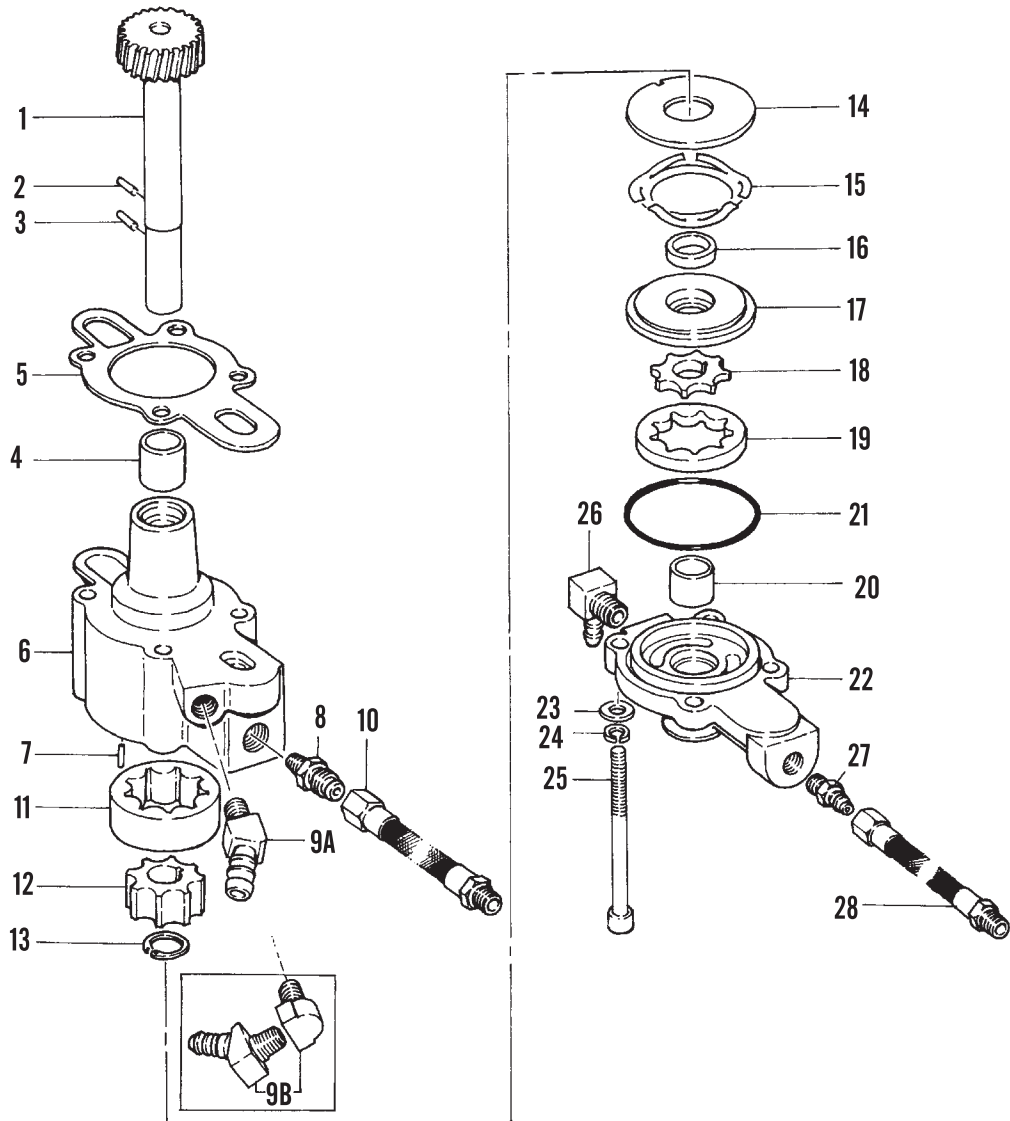

Figure 92 and **Figure 93**. Measure the assembled clearance with a flat feeler gauge as shown in **Figure 94**.

6. Measure the thickness of the inner and outer feed gerotors (**Figure 95**). If both pieces are not the same thickness, replace them as a set.
7. Assemble the feed gerotor assembly into the cover (**Figure 96**). Perform the following:

75

**OIL PUMP
(1986-1990)**



- | | |
|--------------------------------|--------------------------|
| 1. Gearshaft | 15. Spring washer |
| 2. Pin | 16. Outer plate seal |
| 3. Pin | 17. Outer plate |
| 4. Bushing | 18. Feed gerotor (inner) |
| 5. Gasket | 19. Feed gerotor (outer) |
| 6. Body | 20. Bushing |
| 7. Roll pin | 21. O-ring |
| 8. Fitting | 22. Cover |
| 9A. Fitting (1986-1987 models) | 23. Flat washer |
| 9B. Fitting (1988-1990 models) | 24. Lockwasher |
| 10. Oil line (1/4 in.) | 25. Bolt |
| 11. Scavenger gerotor (outer) | 26. Elbow fitting |
| 12. Scavenger gerotor (inner) | 27. Fitting |
| 13. Circlip | 28. Oil line (1/8 in.) |
| 14. Inner plate | |

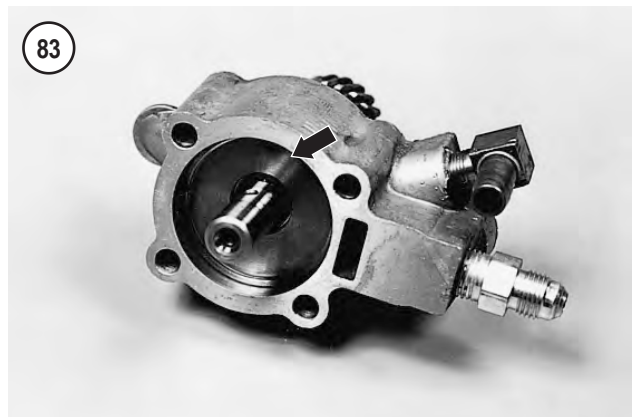
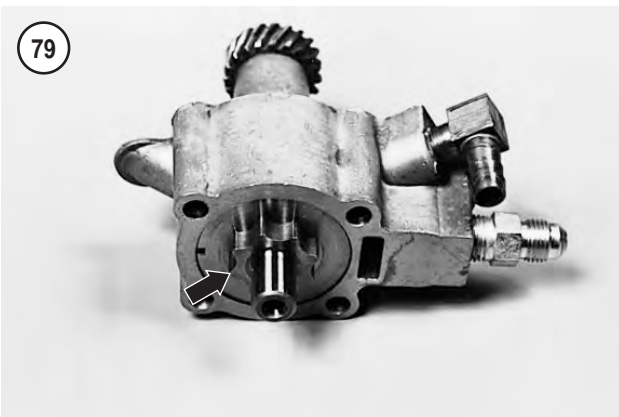
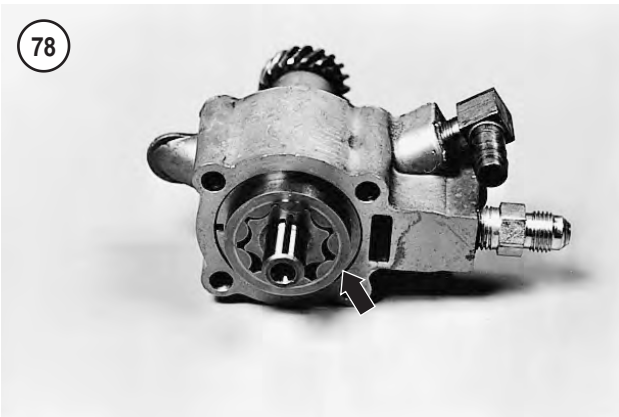
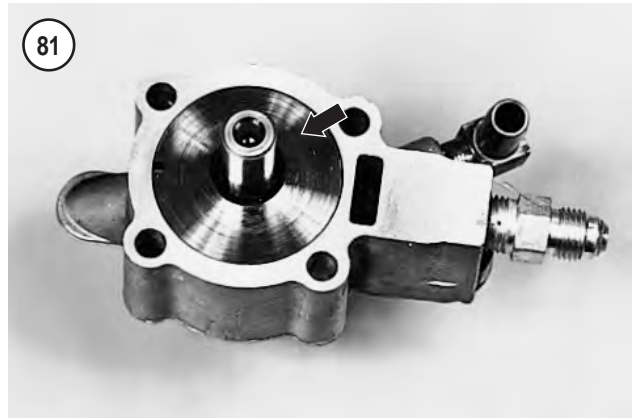
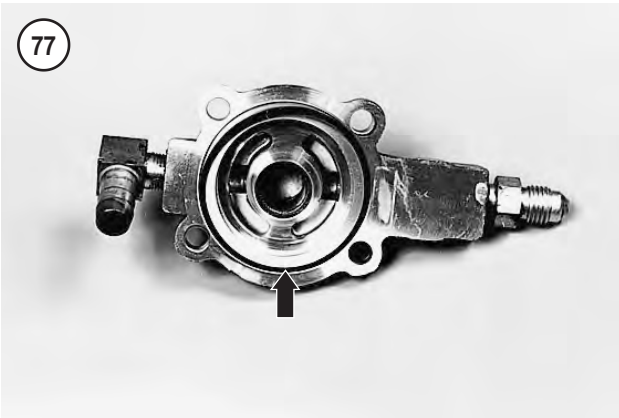
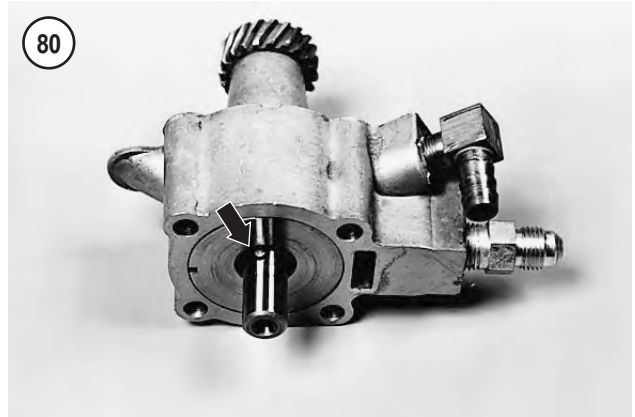
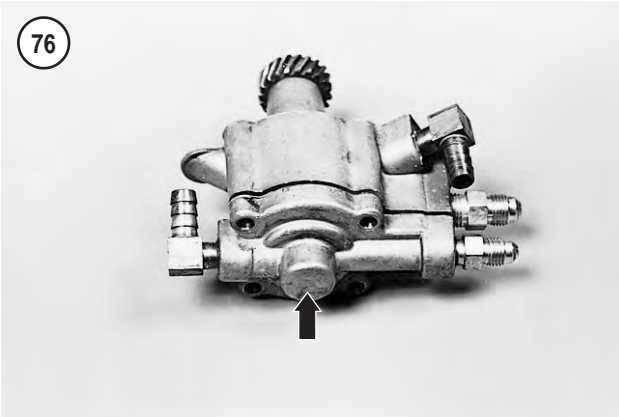

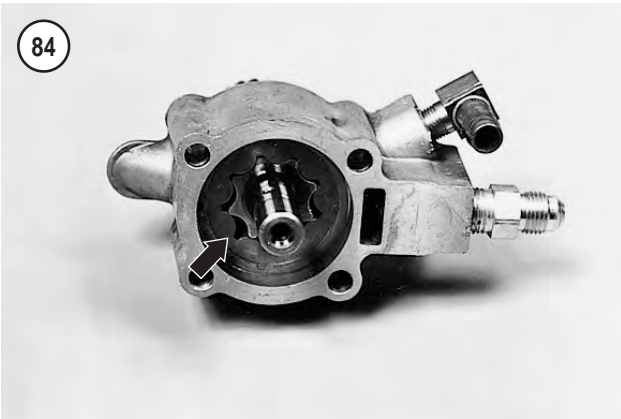

5

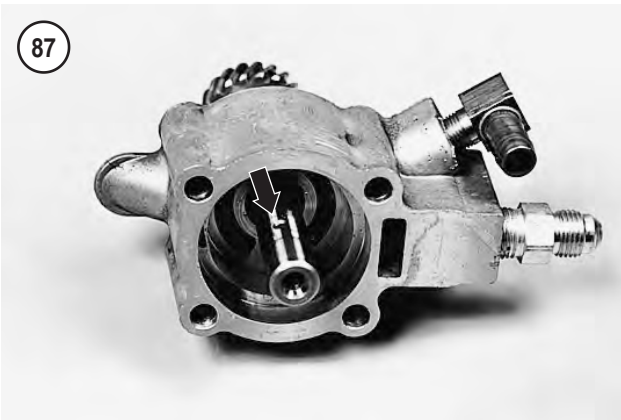
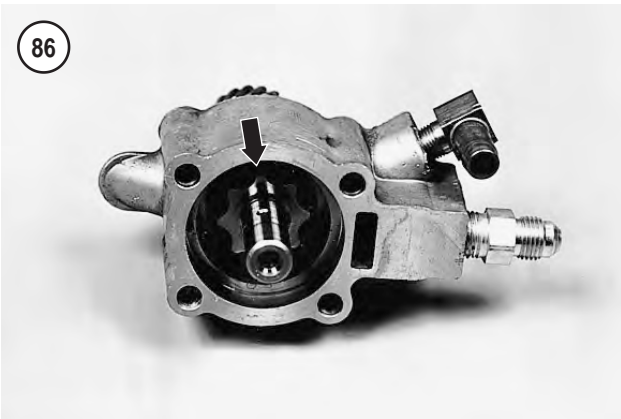
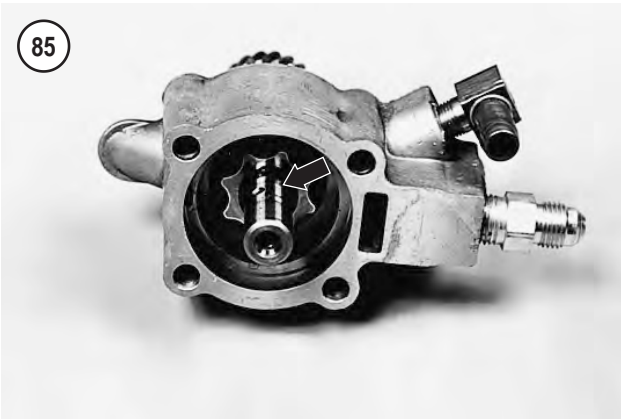



- a. Place a straightedge over the gerotors as shown in **Figure 97**. Both gerotors must be the same height. If not, replace the cover.
- b. Insert a flat feeler gauge between the straightedge and the flange of the cover (**Figure 98**). If the distance is not within specification, replace the cover.

8. Inspect the bushing in the body (**Figure 99**) and in the cover (**Figure 100**) for scoring, wear and damage. If worn, replace the bushings as described in this section.

9. Inspect the gearshaft pinion gear teeth. Replace the shaft if any of the teeth are damaged or if they are severely worn.

10. If the bushing(s) and gearshaft condition is okay as checked in Step 8 and Step 9, check the shaft-to-bushing clearance in the body and cover. If the clearance is not within specification, replace the bushings as described in this section.

11. Inspect the gerotor machined surfaces in the body and cover for scoring or cracks. Replace the oil pump if these parts are damaged.

Oil Pump Bushing Replacement

Replacement of the bushings in the body (**Figure 99**) and cover (**Figure 100**) require a press. When installing new bushings, observe the following:





1. The body bushing (**Figure 99**) should be pressed in 0.100 in. (2.54 mm) below the surface.
2. The cover bushing (**Figure 100**) should be pressed in 0.120 in. (3.05 mm) below the surface.

Assembly

1. Lightly lubricate all parts with fresh engine oil.
2. Install the gearshaft through the body (**Figure 88**).
3. Install the gearshaft pin (**Figure 87**) in the hole closest to the drive gear.
4. Install the scavenger inner gerotor (**Figure 86**).
5. Install the gearshaft circlip (**Figure 85**).
6. Install the scavenger outer gerotor (**Figure 84**).
7. Align the notch in the inner plate with the roll pin installed in the body and install the inner plate. See **Figure 83**.
8. Install the spring washer (**Figure 82**) so that its fingers face the inner plate.
9. Align the notch in the outer plate (**Figure 81**) with the roll pin in the body and install the outer plate. The outer plate seal lip (**Figure 89**) should face into the pump body. **Figure 81** shows the outer plate correctly installed.
10. Install the push pin (**Figure 80**) into the gearshaft.

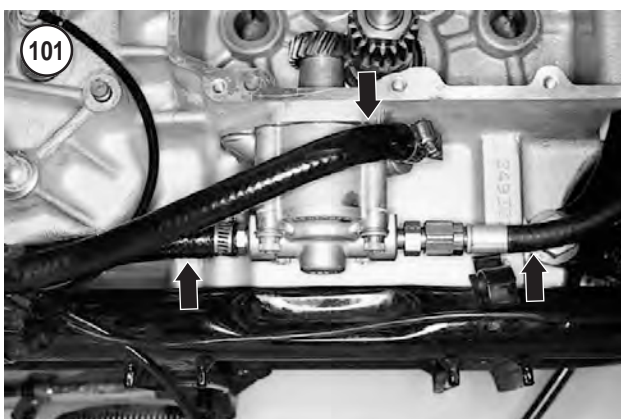

11. Install the feed gerotor inner (**Figure 79**) and outer (**Figure 78**) gears. Make sure the notch in the inner gerotor meshes with the gear shaft pin.
12. Install a new O-ring into the cover groove (**Figure 77**).
13. Assemble the cover (**Figure 76**) onto the body.
14. Install the oil pump screws and install the oil pump as described in this chapter.

OIL PUMP (1991-2003 MODELS)

The oil pump (**Figure 101**) is mounted underneath the front of the engine and can be removed with the engine installed in the frame and without removing the gearcase cover.

The oil pump consists of two sections: a feed pump, which supplies oil under pressure to the engine components, and a scavenger pump, which returns oil to the oil tank from the engine.

Removal

NOTE

Label all gears and Woodruff keys during removal so that they can be installed in their original positions.

1. Drain the oil tank (Chapter Three).
2. Wipe off each oil line and fitting at the oil pump.
3. Label each oil line (**Figure 101**) prior to disconnecting it.
4. Disconnect the oil lines from the oil pump. Plug the open end of each line to prevent leaks and contamination.
5. Loosen the oil pump mounting bolts (**Figure 102**). Remove the bolts and oil pump from the engine (**Figure 103**).
6. Remove and discard the oil pump gasket.
7. Cover the oil pump opening to keep dirt and debris from entering the engine.
8. Store the oil pump in a plastic bag until disassembly or installation.

Disassembly

Refer to **Figure 104**.

1. Remove the oil pump housing screws (A, **Figure 105**), lockwashers and flat washers.
2. Remove the oil pump cover (B, **Figure 105**).
3. Remove and discard the O-ring (**Figure 106**).
4. Slide off the feed rotor assembly (**Figure 107**).
5. Remove the separator plate (**Figure 108**).
6. Slide off the scavenge rotor assembly (**Figure 109**).
7. Remove and discard the retaining ring (**Figure 110**).
8. Remove the thrust washer (**Figure 111**).
9. Remove the oil pump gearshaft (**Figure 112**).

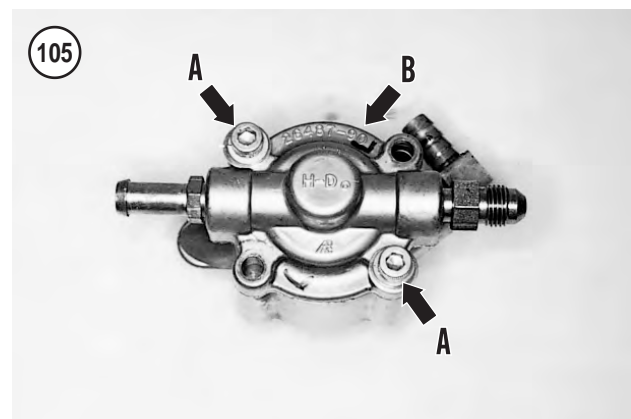
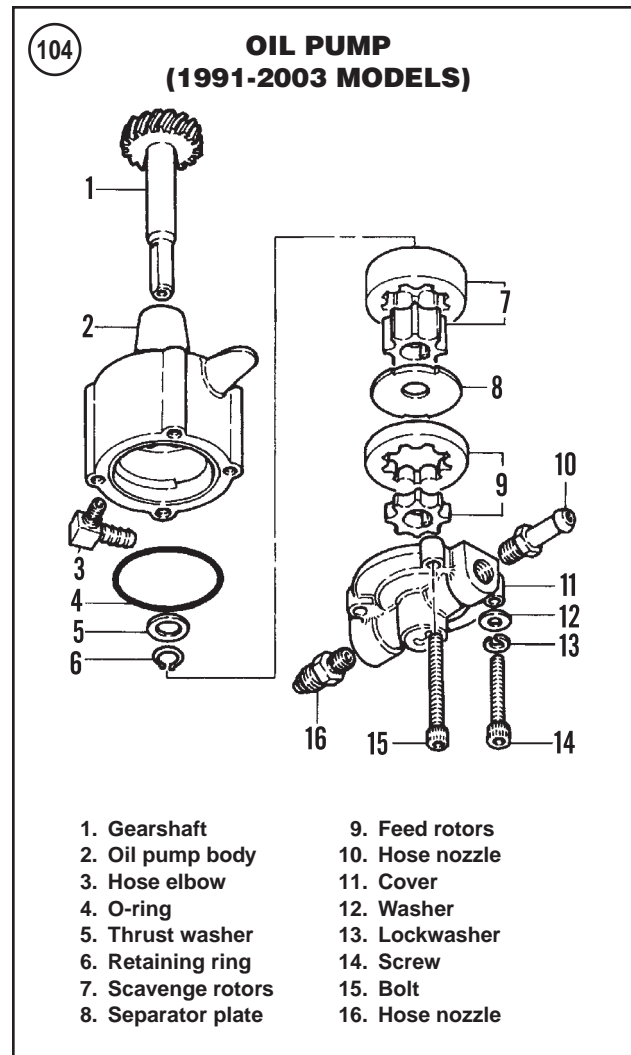

Inspection

1. Clean all the parts in solvent and blow dry. Blow out all oil passages with compressed air. Place cleaned parts on a clean, lint-free cloth during inspection and reassembly.
2. Inspect the cover and body (**Figure 113**) for scratches, scoring or severe wear. Both rotor inside surfaces will show



some scoring but it should not be excessive. If these areas are heavily scored, replace the oil pump assembly.

3. Inspect the gear shaft assembly (**Figure 114**) for wear. The gear will show signs of pattern polish but there should be no other apparent wear or damage.

4. Check the fit of the gear shaft where it passes through the oil pump body (**Figure 112**). The shaft should turn smoothly with no binding or excessive play.

5. Inspect the separator plate (**Figure 115**) for warp, cracks or other damage.

6. Check both rotor sets (**Figure 116**) for scoring, cracks or excessive wear.

7. Measure the thickness of each feed rotor (**Figure 117**). Both rotors must be the same thickness. If they are not the same thickness, replace the feed rotors as a set.

8. Assemble the feed rotors and measure the clearance between the gear teeth as shown in **Figure 118**. If the gear clearance is worn to the service limit in **Table 1**, replace the feed rotors as a set.

9. Assemble the scavenge rotors and measure the clearance between the gear teeth as shown in **Figure 119**. If the gear clearance is worn to the service limit in **Table 1**, replace the scavenge rotors as a set.

Reassembly

Refer to **Figure 104**.

NOTE

*All parts must be clean prior to assembly. If necessary, reclean as described in **Inspection** in this section.*

1. Coat all moving parts with clean engine oil prior to assembly.

2. Install the gear shaft (**Figure 112**) through the bottom of the oil pump body.

3. Install the thrust washer (**Figure 111**) onto the gearshaft.

4. Install a *new* retaining ring (**Figure 110**) into the gearshaft groove. Make sure the ring seats in the groove completely. Turn the gearshaft by hand; the shaft should turn smoothly with no binding or excessive play.

5. Install the inner and then the outer scavenge rotors. See **Figure 109**.

6. Install the separator plate (**Figure 120**) into the oil pump body; align the separator plate slots with the tabs inside the pump body.

7. Install the feed rotors (**Figure 107**) over the gearshaft.

8. Install a *new* O-ring (**Figure 106**) into the oil pump cover groove.

9. Install the pump cover (B, **Figure 105**) onto the pump body. Install oil pump screws, lockwashers and flat washers (A, **Figure 105**). Tighten the screws to 70-80 in.-lb. (7-9 N•m).

10. Turn the gear shaft by hand; the pump should turn smoothly.

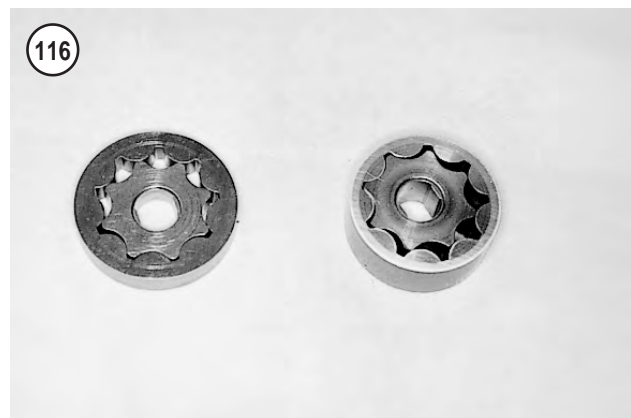
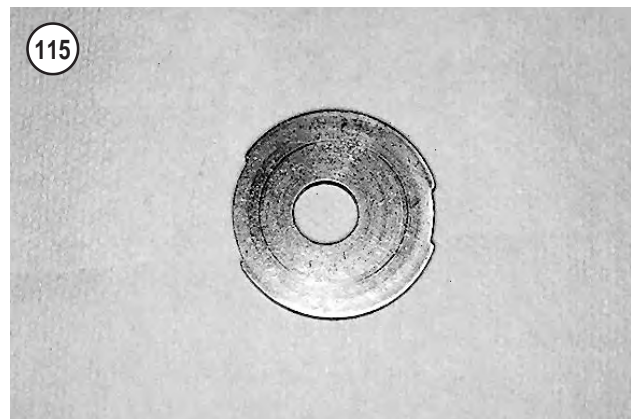

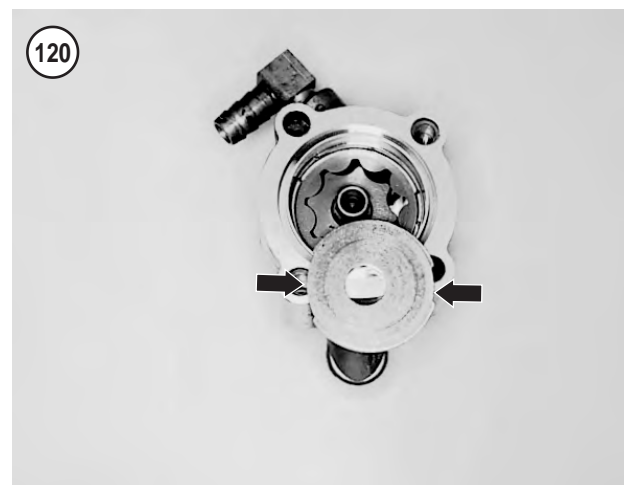
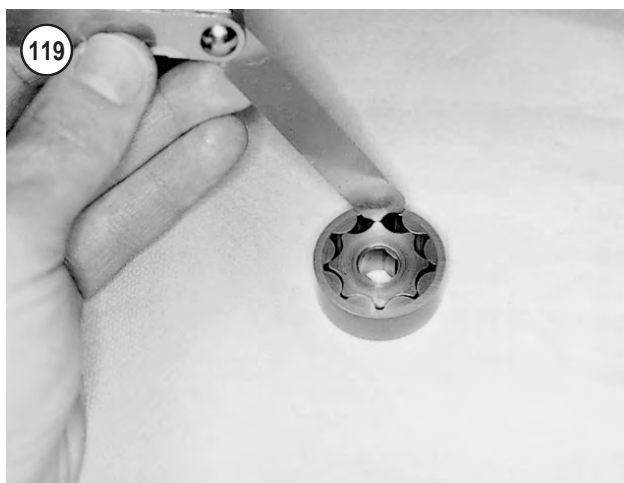
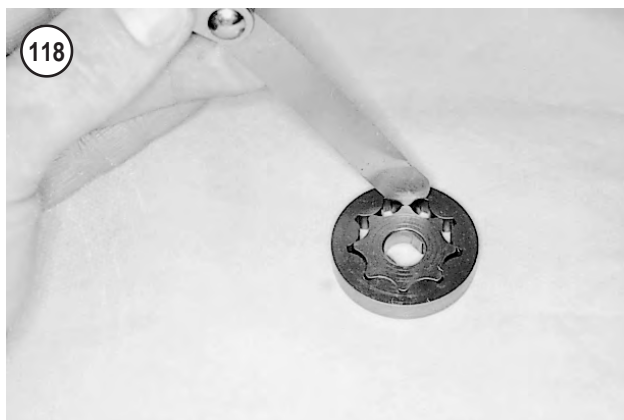

NOTE
If the oil hose fittings were removed from the oil pump, apply pipe sealant to the fitting threads prior to installation.

Installation

1. Thoroughly clean the oil pump and engine case gasket surfaces.

2. Install a new oil pump gasket. Then install the oil pump onto the crankcase. Tighten the oil pump mounting screws (**Figure 102**) to 125-150 in.-lb. (14-17 N•m).

NOTE
When installing the original equipment (OE) hose clamps, refer to Chapter Four. A screw-type hose clamp may be substituted in place of the OE hose clamp.

3. Unplug, then reconnect the oil hoses (**Figure 101**) at the oil pump. Secure each hose with new hose clamps.

NOTE
If the oil hose fittings were removed from the oil pump, apply pipe sealant to the fitting threads prior to installation.

4. Refill the oil tank (Chapter Three).

OIL FILTER MOUNT (1986-1990 MODELS)

The oil filter mount is located on the right crankcase half. The oil filter mount houses the oil filter, check ball or valve and spring, and oil pressure switch. Refer to **Figure 121**.

Removal/Installation

1. Drain the engine oil (Chapter Three).
2. If it is necessary to disassemble the oil filter mount, remove the oil filter.
3. Disconnect the electrical connector from the oil pressure regulator switch (Chapter Twelve).
4. Disconnect the two pressure hoses (**Figure 122**) from the oil pump.
5. Remove the filter mount-to-gearcase bolts and pull the filter mount away from the gearcase.
6. Remove the quad seal (2, **Figure 121**).
7. Installation is the reverse of the preceding steps while noting the following.
 - a. Install a *new* quad seal.
 - b. Refill the engine oil and install the oil filter as described in Chapter Three.
 - c. Prime the oil pump as described in *Engine Oil and Filter Change* (Chapter Three).

Disassembly/Reassembly

1. Disconnect the two pressure hoses from the filter mount (**Figure 122**).
- 2A. On 1986-early 1987 models, remove the oil filter adapter as follows:
 - a. Unscrew the filter adapter.
 - b. Push the check valve out of the filter adapter with a 5/16 in. (7.94 mm) diameter rod.

- c. Discard the check valve O-ring.
- 2B. On late 1987-1990 models, remove the oil filter adapter as follows:
 - a. Unscrew the filter adapter.
 - b. Remove the check ball and spring.
3. Remove the oil pressure switch (Chapter Twelve).
4. Unscrew the plug, and then remove the oil pressure regulator plunger, spring and washer.
5. Clean all metal parts in solvent. Allow to dry thoroughly.
6. Inspect the check valve by moving the spring-loaded cup inside the valve. The cup must move freely and return to its closed (seated) position. Replace the valve if necessary.
7. Replace the pressure regulator plunger and spring if damaged.
8. Assemble by reversing Steps 1-4. Note the following.
 - a. Install *new* O-rings.

WARNING

If the check valve is installed backwards, the oiling system will not operate properly and engine seizure will result.

NOTE

The check valve is installed correctly if the brass portion of the valve is visible.

- b. Install the check valve so that the arrow on the valve faces toward the oil filter adapter (direction of oil flow).
- c. Use pipe sealant on all fittings and plugs.
- d. On late 1987-1990 models, install the oil filter adapter so that the end with the smaller diameter faces the check ball.
- e. Apply threadlock (Loctite 242 or equivalent) to the oil filter adapter before installation. Tighten the adapter securely.
- f. Tighten the plug to 15-20 ft.-lb. (20-27 N•m).
- g. Tighten the oil pressure switch to 60-70 in.-lb. (7-8 N•m).
9. Install the oil filter and refill with oil (Chapter Three).
10. Start the engine and check for oil leaks.

OIL FILTER MOUNT (1991-2003 MODELS)

The oil filter mount is part of the right crankcase half. The oil filter mount houses the oil filter, check ball and spring, and oil pressure switch. See **Figure 123**.

Disassembly

Refer to **Figure 123**.

1. Drain the oil and remove the oil filter (Chapter Three).
2. Remove the oil filter adapter (A, **Figure 124**, typical) from the oil filter mount.

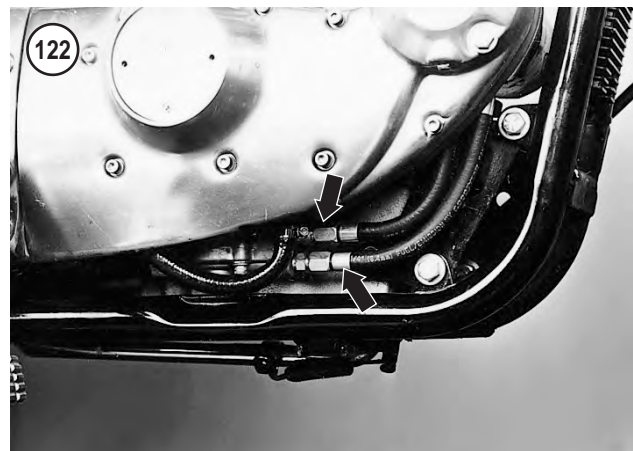
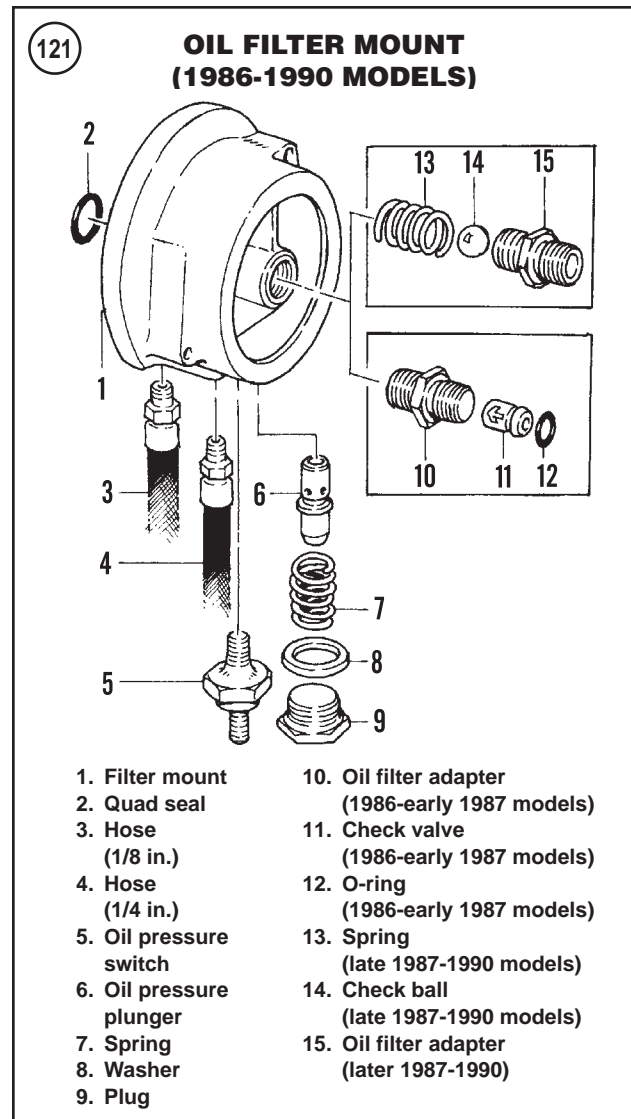

3. Remove the check ball and spring (**Figure 125**, typical).
4. Disconnect the electrical connector from the oil pressure switch (Chapter Twelve).
5. Remove the oil pressure switch (B, **Figure 124**).

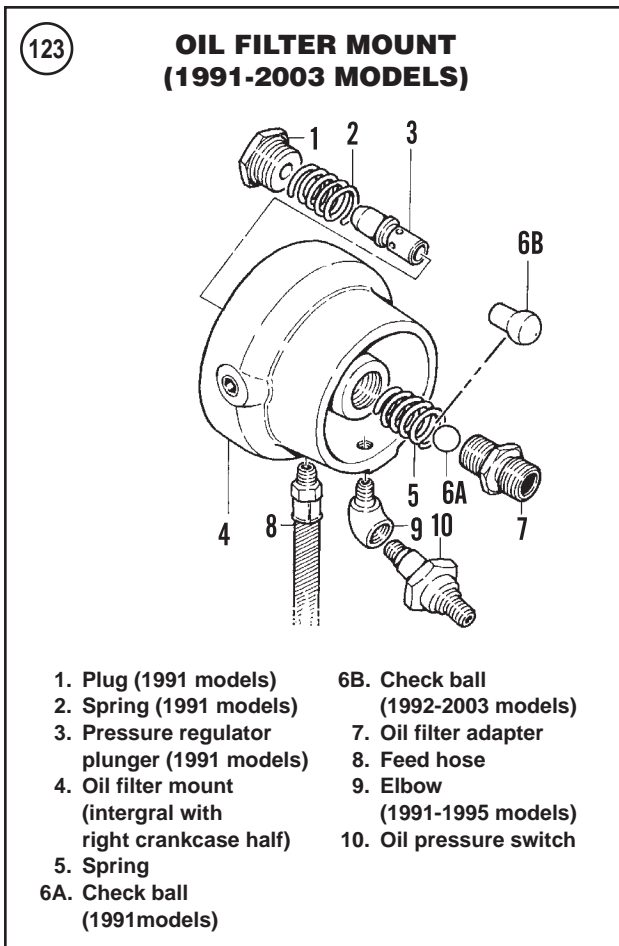

Inspection

1. Remove thread sealant residue from all threaded parts.
2. Clean the check ball, spring and oil filter adapter in solvent and dry thoroughly.

Reassembly

1. Apply pipe sealant to the oil pressure switch threads prior to installation. Install the switch and tighten to 60-70 in.-lb. (7-8 N•m).
2. Install the oil filter adapter as follows:
 - a. The ends on the oil filter adapter are symmetrical; either end may be installed into the oil filter mount.
 - b. Apply threadlock (Loctite 243 or equivalent) onto the oil filter adapter threads that will be installed into the oil filter mount. Do not install thread sealant on the oil filter end.
 - c. Install the spring, and then the check ball into the hole in the center of the oil filter mount (**Figure 125**). Then push the oil filter adapter (threadlock end) against the check ball and thread it into the oil filter mount. Tighten the oil filter adapter to 96-144 in.-lb. (11-16 N•m).
3. Reconnect the electrical wire onto the oil pressure switch (Chapter Twelve).
4. Install the oil filter and refill with oil (Chapter Three).
5. Start the engine and check for oil leaks.

5

CRANKCASE AND CRANKSHAFT

NOTE

In Harley-Davidson terminology, the crankshaft is called the flywheel. The crankshaft's left shaft is referred to as the sprocket shaft; the right shaft is referred to as the pinion shaft.

The crankcase must be disassembled to service the crankshaft, connecting rod bearings, pinion shaft bearing and sprocket shaft bearing. Some specialized service procedures, such as bearing and crankshaft service, should be referred to a dealership.

A press and special tools are required to perform the following service procedures. Refer to **Figures 126-128** when servicing the crankcase and crankshaft.

Crankshaft End Play

Measuring crankshaft end play provides an indication of sprocket shaft bearing wear. Crankshaft end play is controlled by a shim placed on the crankshaft sprocket shaft (8, **Figure 128**). Measure crankshaft end play prior to disassembling the crankcases.

When measuring end play, the crankshaft must be moved in and out. To do this, a tool must be fabricated prior to

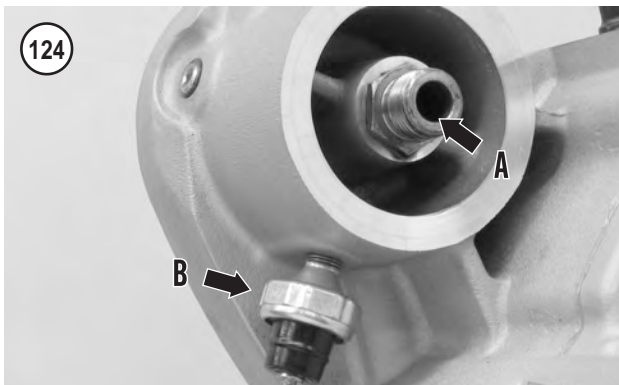

166

**CRANKCASE FASTENERS
(1986-1990 MODELS)**

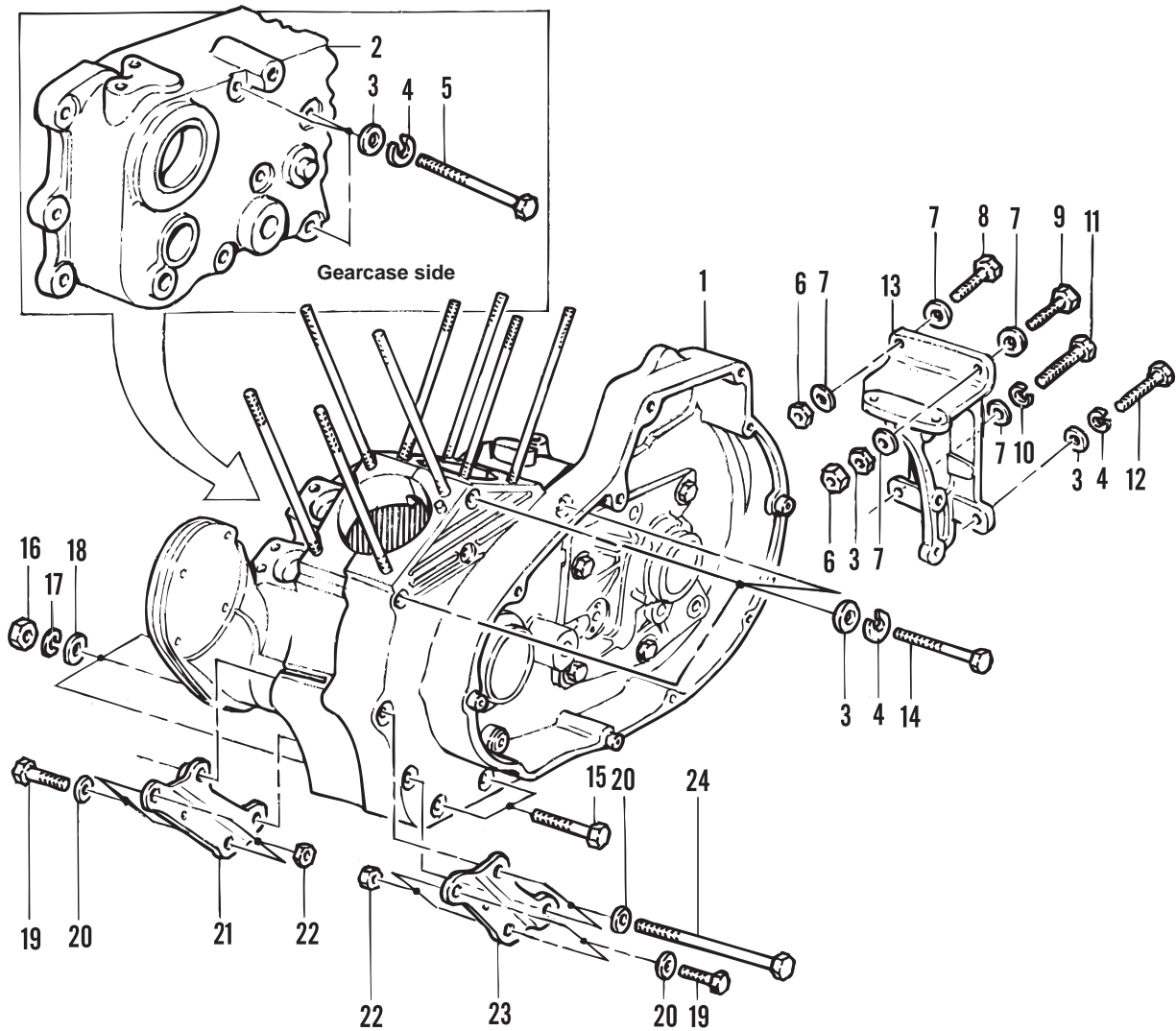

- | | |
|--------------------------|-------------------------------------|
| 1. Crankcase | 13. Rear engine mount |
| 2. Right, rear crankcase | 14. Bolt |
| 3. Washer | 15. Bolt |
| 4. Lockwasher | 16. Nut |
| 5. Bolt | 17. Lockwasher |
| 6. Nut | 18. Washer |
| 7. Washer | 19. Bolt |
| 8. Bolt | 20. Washer |
| 9. Bolt | 21. Right, front lower engine mount |
| 10. Lockwasher | 22. Nut |
| 11. Bolt | 23. Left, front lower engine mount |
| 12. Bolt | 24. Bolt |

127

CRANKCASE FASTENERS (1991-2003 MODELS)

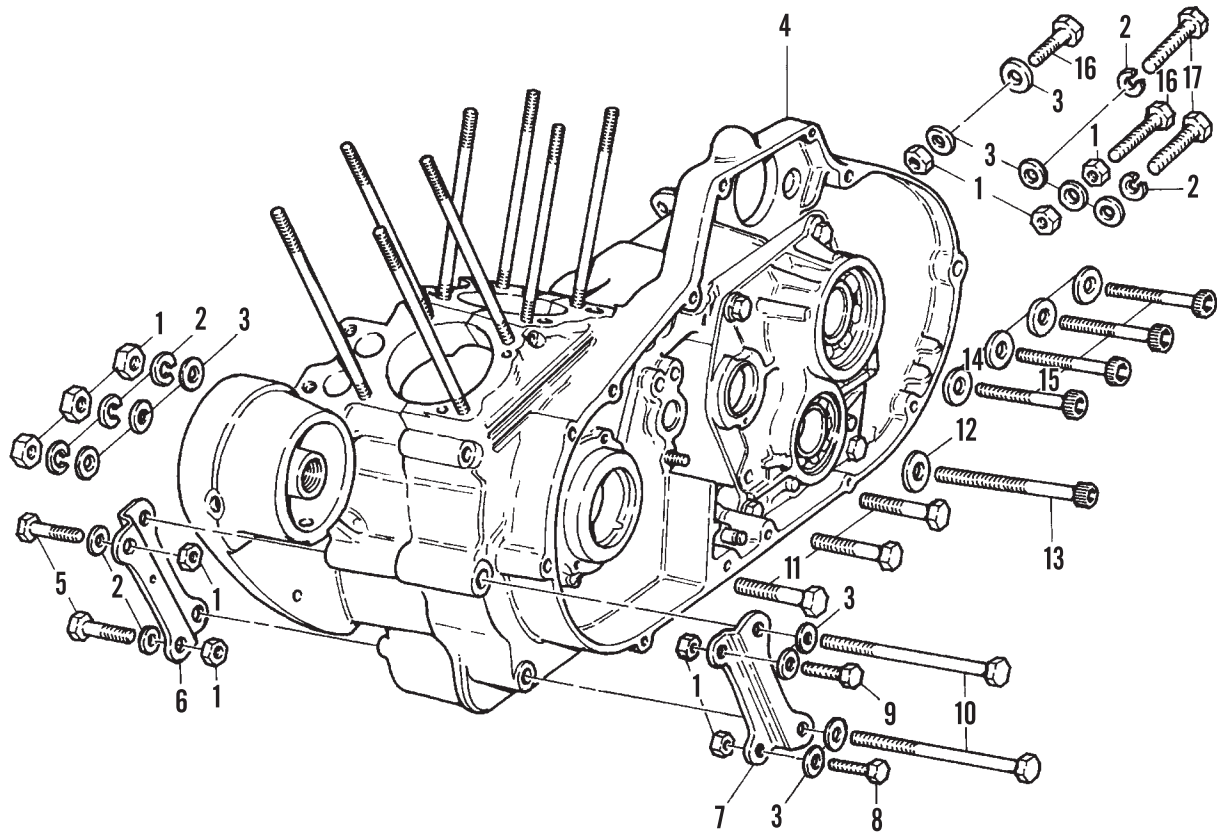

1. Nuts
2. Lockwashers
3. Washers
4. Crankcase
5. Bolt
6. Right lower engine mount
7. Left lower engine mount
8. Bolt
9. Bolt

10. Bolt
11. Bolt (3/4 in. [19 mm] long)
12. Washer
13. Bolt (3-3/4 in. [95.25 mm] long)
14. Washers
15. Bolts (2-1/2 in. [63.5 mm] long)
16. Bolts
17. Bolts

checking end play. The tool can be made by welding two handles onto a spare sprocket shaft nut.

1. Remove the engine from the frame as described in this chapter.
2. Remove the gearcase cover as described in this chapter.
3. Remove the primary chain and sprocket as described in Chapter Six or Chapter Seven.
4. Secure the crankcase to a workstand or workbench.
5. Attach a dial indicator so that the plunger touches against the end of the crankshaft as shown in **Figure 129**.

NOTE

The sprocket shaft bearings (left side) must be preloaded when measuring crankshaft end play.

6. Install the engine sprocket onto the sprocket shaft. Then thread the sprocket nut tool (with handles) onto the sprocket shaft and tighten to the specification listed in **Table 3**.
7. Pull the sprocket shaft (**Figure 129**) in and out and note the crankshaft end play reading on the dial indicator. If the total indicator reading is not within the crankshaft end play

128

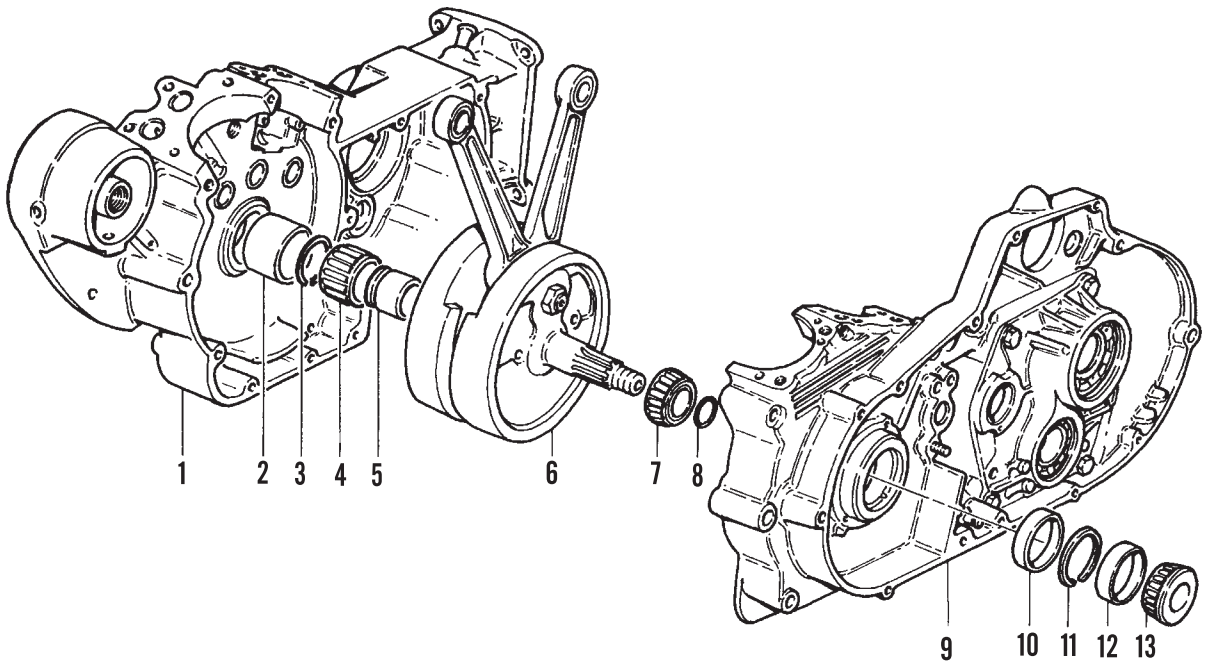
CRANKCASE/CRANKSHAFT ASSEMBLY

(Align circlip opening
with oil feed hole)

1. Right crankcase half
2. Pinion shaft bearing outer race
3. Retaining ring
4. Pinion shaft bearing
5. Pinion shaft bearing inner race
6. Crankshaft
7. Right sprocket shaft bearing

8. Shim
9. Left crankcase half
10. Sprocket shaft right-hand outer race
11. Lock ring
12. Left sprocket shaft outer race
13. Left sprocket shaft bearing

specification listed in **Table 1**, the inner shim (8, **Figure 128**) must be replaced. Select the correct size shim from **Table 2**.

8. Remove the dial indicator, sprocket shaft nut tool and engine sprocket.

Crankcase Disassembly

A press will be required to remove the crankshaft.

1. Remove the engine from the frame as described in this chapter.

CAUTION

After removing the cylinders, slip hoses (**Figure 130**) over the cylinder studs to avoid damaging them during the following service procedures. In addition, do not lift the crankcase assembly by grabbing the cylinder studs. Bent or damaged cylinder studs may cause oil leaks.

129

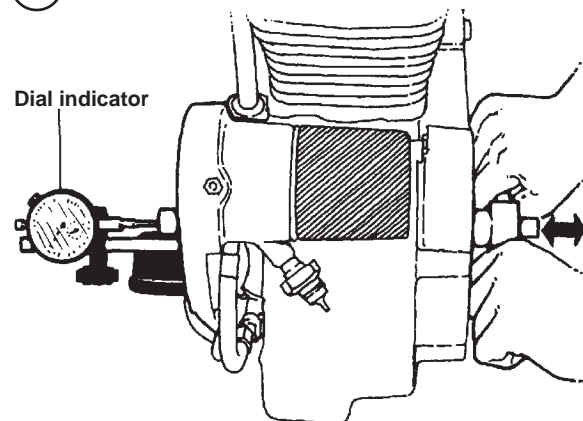

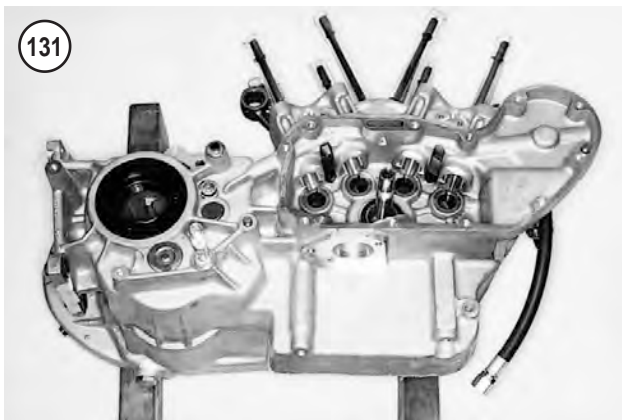

2. Disassemble and remove the gearcase as described in this chapter.
3. Check the crankshaft end play as described in this chapter.
4. Loosen, then remove the crankcase bolts and washer (**Figure 126** and **Figure 127**).
5. Lay the crankcase on wood blocks so that the right side (**Figure 131**) faces up.
6. Tap the crankcase with a plastic mallet and remove the right crankcase half.
7. Remove the dowel pins.

WARNING

A press is required to remove the crankshaft. To prevent eye damage from parts flying out while under pressure, wear safety glasses.

CAUTION

Do not attempt to remove the crankshaft by driving it out with a hammer. The force may knock the flywheels out of alignment and damage the sprocket shaft threads.

8. Press the crankshaft out of the left crankcase half as follows:
 - a. Support the left crankcase half in a press with parallel bars or wood blocks as shown in **Figure 132**. Check that there is adequate room for the crankshaft and connecting rods as the crankshaft is being pressed out.
 - b. Center the press ram with the sprocket shaft, and then press the crankshaft from the case half. Support the bottom of the crankshaft to prevent it from falling to the floor.

Inspection

1. Measure the connecting rod side play with a feeler gauge as shown in **Figure 133**. If the side play is not within the specifications in **Table 1**, refer service to a dealership.
2. Inspect the piston pin bushings (**Figure 134**) for wear and damage. Replace the bushings as described in Chapter Four.
3. Inspect the connecting rods (**Figure 135**) for damage.

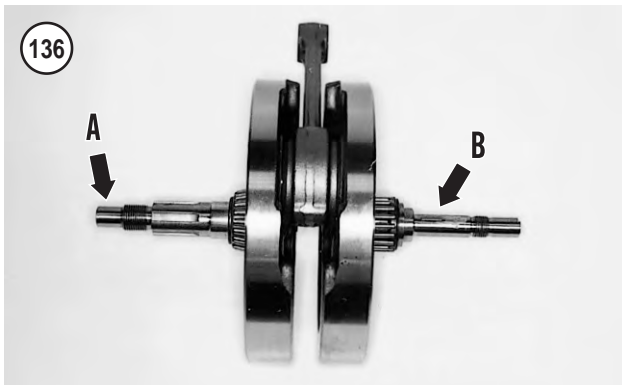

4. Inspect the sprocket shaft (A, **Figure 136**) and pinion shaft (B) for severe wear or damage. If damaged, refer replacement to a dealership.

NOTE

*If still in place, do not lose the shim (8, **Figure 128**) when performing Step 5.*

5. Inspect the sprocket shaft bearing (**Figure 137**) for severe wear or damage. If damaged, replace the bearing and races as described in the *Sprocket Shaft Main Bearing Assembly Replacement* section.

6. Inspect the pinion shaft needle bearing (**Figure 138**) for severe wear or damage. If the bearing is worn or damaged, refer replacement to a dealership.

7. Support the crankshaft on a truing stand or in a lathe and check runout at the shaft with a dial indicator and compare it to the runout limit in **Table 1**. If not within specification, refer service to a dealership.

8. Remove the left crankcase oil seal as follows:

- On 1991-2003 models, remove the spacer (**Figure 139**).
- Pry the oil seal out of the crankcase with a wide-blade screwdriver (**Figure 140**). Pad the screwdriver to avoid damaging the case.

9. Remove the left sprocket bearing (**Figure 141**). If damaged, replace the bearing and races as described in the *Sprocket Shaft Main Bearing Assembly Replacement* section.





10. Inspect the bearing races in the left crankcase half (**Figure 141**). If damaged, replace the bearings and races as described in the *Sprocket Shaft Main Bearing Assembly Replacement* section.

Sprocket Shaft Main Bearing Assembly Replacement

Replace the sprocket shaft main bearing assembly as a complete set even if only one bearing or race is damaged.

Tools

1. Hydraulic press.
2. Sprocket shaft bearing race tool (part No. 94547-80B).
3. Race and bearing installation tool handle (part No. 33416-80).
4. Retaining ring removal and installation tool (part No. 1710).
5. Sprocket bearing race installation tool (part No. 2246).

Inner and outer bearing race replacement

CAUTION

When replacing the bearing races in the following steps, do not remove the retaining ring installed between the inner and outer bearing races unless a removal tool is available. This ring is under heavy tension and will damage the crankcase bearing bore as it passes through it.

1. Place the crankcase on the workbench with the inboard surface facing up.
2. If still in place, remove the crankshaft spacer, if used, and oil seal from the bearing bore.
3. Install half of the bearing race remover into the crankcase and push it against the inner bearing race (**Figure 142**).
4. Install the other half of the bearing race remover tool into the crankcase and push it against the inner bearing race (**B, Figure 142**).
5. Hold the bearing race remover tools in place.
6. Insert the tool handle into the center of both race remover tools. Press it in until the ring (**Figure 143**) is locked into both bearing race remover tools (**Figure 144**).
7. Support the left crankcase half on the press bed with wooden blocks and with the tool handle facing up.
8. Center the press ram directly over the tool handle and slowly press the inner bearing race out of the crankcase.
9. Remove the crankcase and tools from the press bed.
10. Place the crankcase on the workbench with the outboard surface facing up.
11. Install half of the bearing race remover tool (**A, Figure 145**) into the crankcase and push it against the outer bearing race.

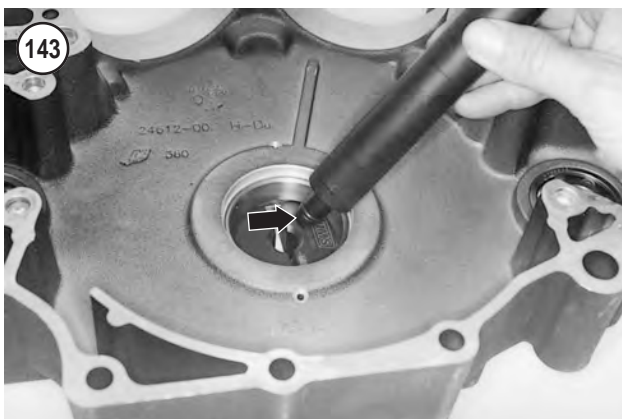
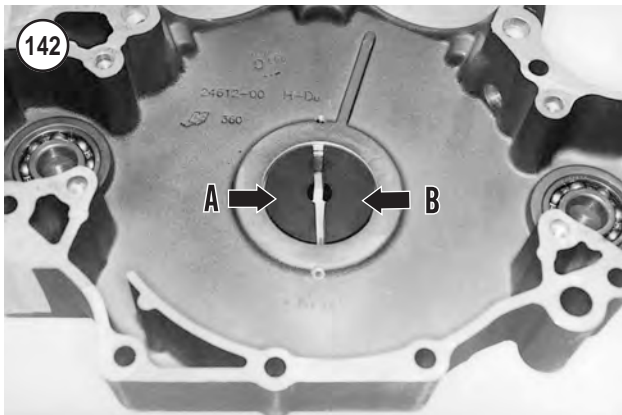

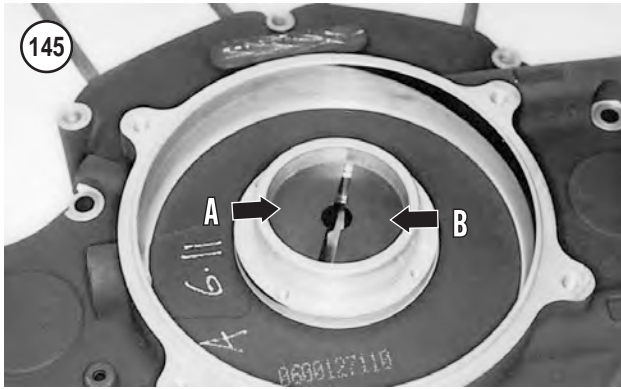

12. Install the other half of the bearing race remover tool (B, **Figure 145**) into the crankcase and push it against the outer bearing race.

13. Hold the bearing race remover tools in place.

14. Insert the tool handle into the race remover tools. Press it in until the ring (**Figure 146**) is locked into both bearing race remover tools (**Figure 147**).

15. Support the left crankcase half on the press bed with wooden blocks and with the tool handle facing up.

16. Center the press ram directly over the tool handle and press the outer bearing race out of the crankcase.

17. Remove the crankcase and tools from the press bed.

18. Clean the crankcase half in solvent and dry it with compressed air.

19. Check the retaining ring (A, **Figure 148**) for looseness or damage. If the retaining ring is loose or damaged, perform the following:

- a. Place the crankcase on a workbench with the out-board side facing up.
- b. With the gap of the retaining ring at the 12 o'clock position, install the tool clamps onto each side of the retaining ring at the 10 o'clock and 2 o'clock positions.
- c. Securely tighten the 9/16 in. Allen screws securing the clamps to the retaining ring.
- d. Use snap ring pliers to compress the retaining ring and withdraw it from the crankcase groove.
- e. Remove the clamps from the old retaining ring and install them onto the new retaining ring.
- f. Squeeze the pliers (**Figure 149**) and insert the retaining ring into the crankcase groove.
- g. Make sure the retaining ring gap is centered on the crankcase oil hole (B, **Figure 148**).

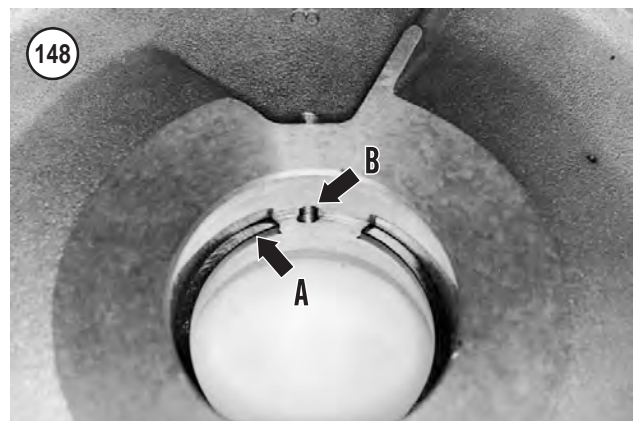

NOTE

Install both races with their larger diameter sides facing out. Install the bearing races with the same tool used to remove the old ones.

20. Apply clean engine oil, or press lube, to the bearing receptacles in the crankcase and to the outer surface of the inner bearing races.

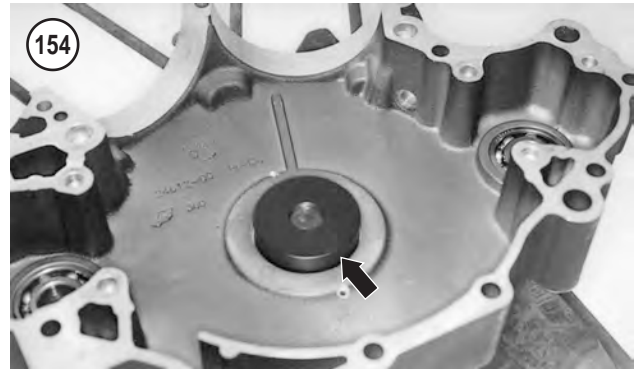
**NOTE**

The large end of the installer base must contact the crankcase outer surface as shown in Figure 150.

21. Place the installer base on the press bed with the large end facing up.
22. Install the inboard outer race (**Figure 151**) onto the crankcase receptacle.
23. Position the crankcase with the inboard surface facing up.
24. Install the crankcase onto the installer base so the crankcase retaining ring rests on top of the installer base.
25. Apply clean engine oil, or press lube, to the shaft of the pressing plug (**Figure 152**) and install the pressing plug into the installer base. Push it down onto the bearing outer race (**Figure 153**).
26. Center the press ram directly over the pressing plug and press the outer bearing race into the outboard surface of the crankcase until it touches the retaining ring (**Figure 154**).
27. Remove the crankcase and special tools from the press.
28. Turn the crankcase over and repeat Steps 20-27 for the outboard outer bearing race.

Crankshaft inner sprocket shaft bearing replacement

A sprocket shaft bearing cone installer (part No. HD-37047A for 1986-1997 models or HD-42759 for 1998-2003 models) is required to install the sprocket shaft bearing.

1. Support the crankshaft with the bearing side facing up.
2. Install the bearing splitter under the bearing (**Figure 155**) and tighten it securely.

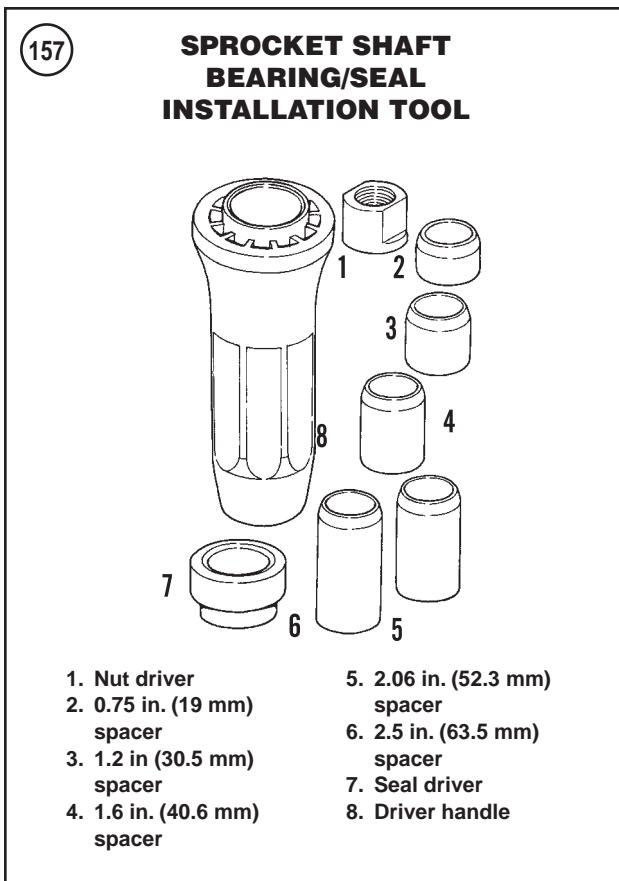

3. Attach a bearing puller to the splitter (**Figure 156**).
4. Tighten the center screw and withdraw the bearing from the crankshaft shoulder.
5. Remove the bearing remover, splitter and bearing from the crankshaft.
6. Clean the sprocket shaft with contact cleaner. Check the sprocket shaft for cracks or other damage. If damaged, refer service to a dealership.
7. Slide the new bearing onto the sprocket shaft.
- 8A. On 1986-1990 models, install the new bearing as follows:
 - a. Place the appropriate sleeve of the sprocket shaft bearing cone installer onto the sprocket shaft so the

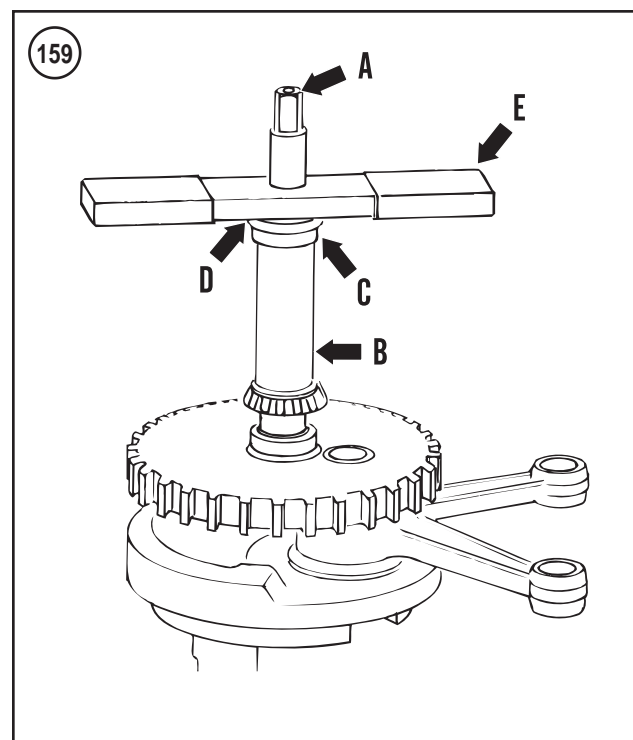
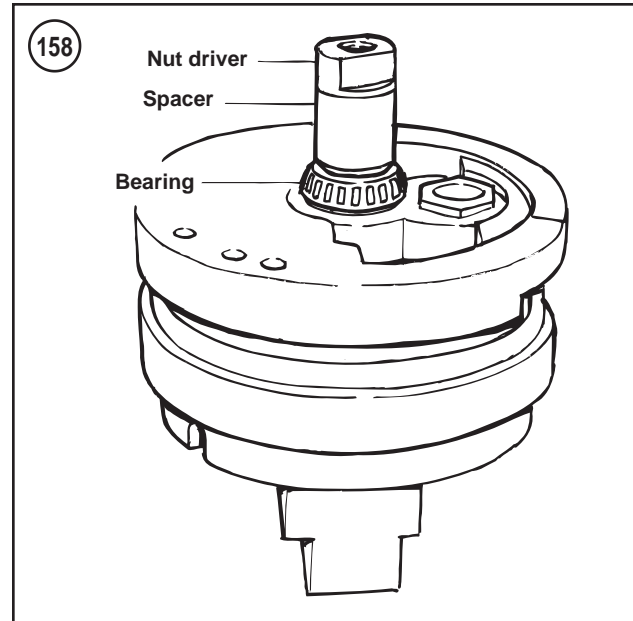

- rounded end of the sleeve contacts the bearing inner race.
- b. Apply clean graphite lubricant to the threads of the tool nut driver (1, **Figure 157**).
- c. Thread the nut driver onto the sprocket shaft it contacts the sleeve (**Figure 158**).
- d. Turn the nut driver to force the bearing onto the sprocket shaft until it bottoms.
- e. Remove the tools.
- 8B. On 1991-2003 models, refer to **Figure 159** and install the new bearing as follows:

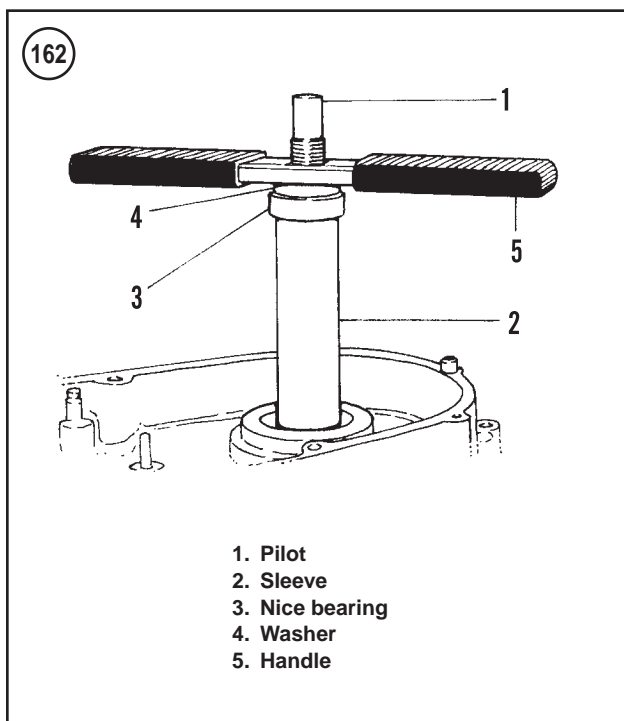
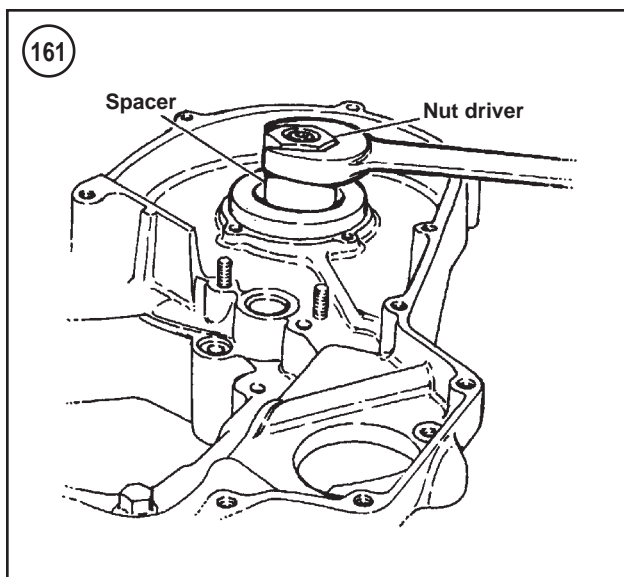

- a. Apply clean graphite lubricant to the threads of the pilot shaft, the flat washer and the bearing.
- b. Thread the pilot shaft (A, **Figure 159**) onto the crankshaft until it contacts the crankshaft shoulder.
- c. Slide the sleeve (B, **Figure 159**) over the pilot shaft until it contacts the bearing inner race.
- d. Install the bearing (C, **Figure 159**) and washer (D) over the pilot shaft and onto the top of the sleeve.
- e. Thread the handle (E, **Figure 159**) onto the pilot shaft (A).
- f. Tighten the handle clockwise until the bearing bottoms on the crankshaft shoulder.
- g. Unscrew and remove all parts of the bearing installer tool.

5

Crankshaft Installation/ Crankcase Assembly

The sprocket shaft bearing installation tool (part No. HD-37047A for 1986-1997 models or HD-42579 for 1998-2003 models) is required to install the sprocket shaft bearing and oil seal.

Refer to **Figure 128**.

1. Be sure the crankshaft pinion shaft and inner sprocket shaft main bearings are installed as described in this section.
2. Lubricate all parts with new engine oil prior to installation.
3. Position the crankshaft in a vise with soft jaws so that the sprocket shaft (**Figure 160**) faces up.
4. Place the left crankcase half over the crankshaft (**Figure 161**).
5. Install the end play shim (8, **Figure 128**) onto the sprocket shaft.
6. Install the left sprocket shaft bearing (13, **Figure 128**) onto the sprocket shaft.
- 7A. On 1986-1997 models, pull the crankshaft into position as follows:
 - a. Slide the 0.75 in. (19 mm) spacer (2, **Figure 157**) over the sprocket shaft so that its flat side faces down.
 - b. Thread the nut driver (1, **Figure 157**) onto the sprocket shaft threads. Tighten the driver until it bottoms out.
 - c. Remove the nut driver and spacer from the sprocket shaft.
 - d. Install the following spacers onto the sprocket shaft so that their flat sides face down: 1.2 in. (30.5 mm), 1.6 in. (40.6 mm) and 2.06 in. (52.3 mm).
 - e. Install the nut driver (1, **Figure 157**) onto the sprocket shaft. Then tighten the nut driver until the left and right bearings (7 and 13, **Figure 128**) and end play shim (8) are drawn together. See **Figure 161**.
 - f. Remove the nut driver and the spacer assembly.
- 7B. On 1998-2003 models, pull the crankshaft into position as follows:
 - a. Thread the pilot (1, **Figure 162**) onto the sprocket shaft until the pilot bottoms.
 - b. Apply a small amount of graphite lubricant to the threads of the pilot shaft.

- c. Slide the sleeve (2, **Figure 162**) onto the pilot until the sleeve contacts the inner bearing race.
- d. Install the Nice bearing (3, **Figure 162**), washer (4) and handle (5).
- e. Turn the handle clockwise until the left and right bearings (7 and 13, **Figure 128**) and end play shim (8) are drawn together.
- f. Remove the tool assembly.

8A. To install the left crankcase oil seal on 1986-1990 models:

- a. Pack the oil seal lip with waterproof grease prior to installation.
- b. Install the oil seal over the sprocket shaft so the closed side faces out. Rest the seal against the crankcase.
- c. Using a seal driver (8, **Figure 157**), press in the oil seal until the driver bottoms or the seal outer surface is flush with the crankcase surface.

8B. To install the left crankcase oil seal on 1991-2003 models three tools are available: (part No. 2324 for 1995-2003 models, HD-37047A with HD-42774 for 1991-1997 models, and HD-42579 with HD-42774 for 1998-2003 models. The first two tools are drivers (**Figure 157**) while the last tool uses the shaft threads to force the seal into place (**Figure 162**).

- a. Pack the oil seal lip with a waterproof grease prior to installation.
- b. Install the spacer into the seal.
- c. Install the oil seal around the sprocket shaft so that the open side faces out. Rest the seal against the crankcase.
- d. Place the installation tool over the sprocket shaft so that the smaller outer diameter of the driver fits between the seal wall and the garter spring.
- e. Force the seal and spacer into the crankcase bore until the spacer contacts the bearing. Remove the installation tool.

CAUTION

Do not remove the spacer after installing it. Removal damages the oil seal, which will require seal replacement.

9. Support the left crankcase assembly on wood blocks as shown in **Figure 163**.
10. Install the crankcase dowel pins (**Figure 164**).
11. Coat the crankcase mating surfaces with sealant (Dow Corning Silastic, 3-M #800 sealant or equivalent).
12. Align the crankcase halves and install the right crankcase half (**Figure 165**).
13. Install the crankcase bolts and washers (**Figure 166** and **Figure 167**).
14. Tighten the 1/4 in. bolts to 70-110 in.-lb. (8-12 N•m).
15. Tighten the 5/16 in. bolts to 16-18 ft.-lb. (21-24 N•m).
16. If the pinion shaft bearing (4, **Figure 128**) was removed, install it as follows:

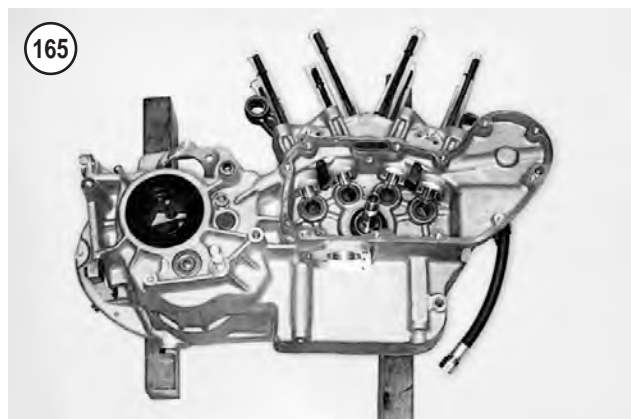
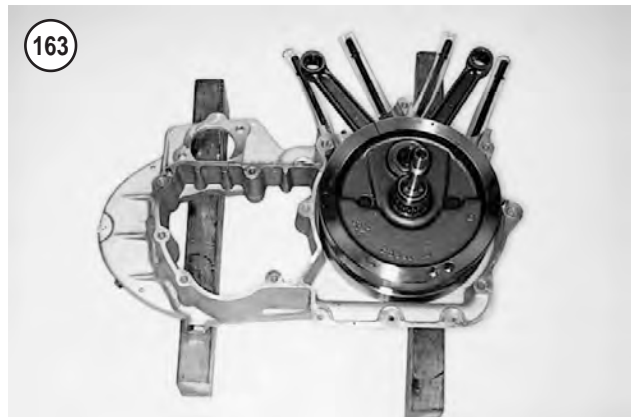

- a. Lubricate the pinion shaft bearing with new engine oil.
- b. Slide the bearing onto the pinion shaft and into the outer bearing race in the right crankcase.
- c. Install a *new* retaining ring (3, **Figure 128**) in the groove in the pinion shaft bearing inner race (5, **Figure 128**).
17. Install the engine in the frame as described in this chapter.
18. Install all of the engine sub-assemblies as described in this chapter.
19. If new engine components were installed, perform the engine break-in as described in this chapter.

166

**CRANKCASE FASTENERS
(1986-1990 MODELS)**

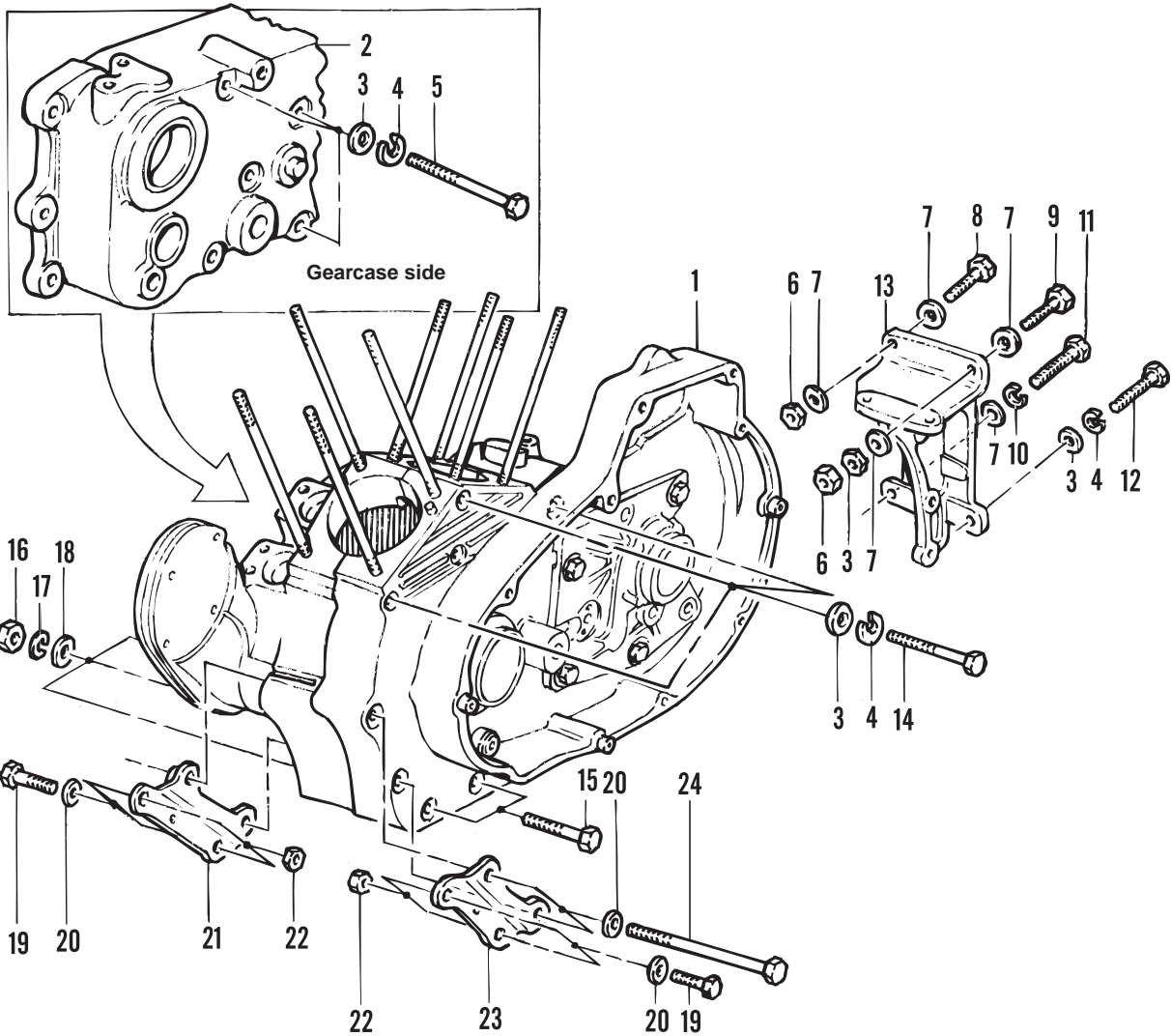

- | | |
|--------------------------|-------------------------------------|
| 1. Crankcase | 13. Rear engine mount |
| 2. Right, rear crankcase | 14. Bolt |
| 3. Washer | 15. Bolt |
| 4. Lockwasher | 16. Nut |
| 5. Bolt | 17. Lockwasher |
| 6. Nut | 18. Washer |
| 7. Washer | 19. Bolt |
| 8. Bolt | 20. Washer |
| 9. Bolt | 21. Right, front lower engine mount |
| 10. Lockwasher | 22. Nut |
| 11. Bolt | 23. Left, front lower engine mount |
| 12. Bolt | 24. Bolt |

167

CRANKCASE FASTENERS (1991-2003 MODELS)

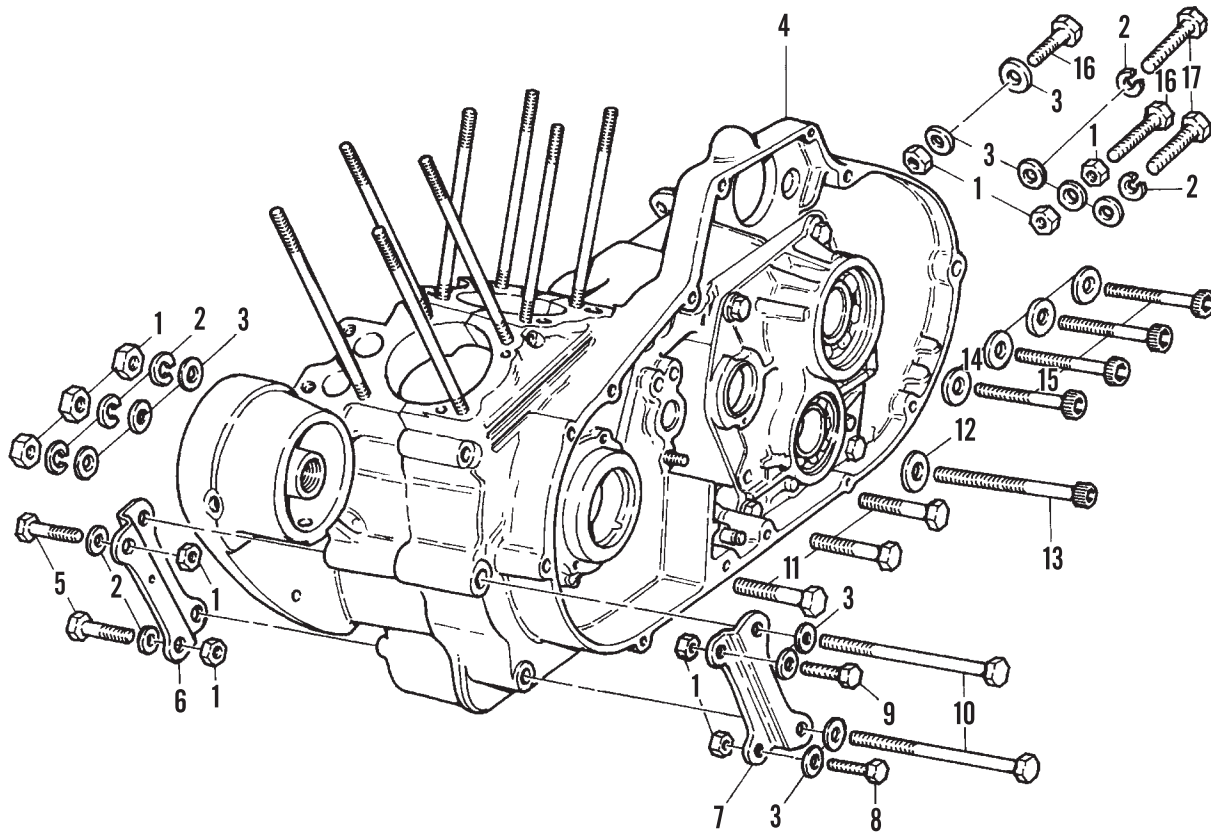

1. Nuts
2. Lockwashers
3. Washers
4. Crankcase
5. Bolt
6. Right lower engine mount
7. Left lower engine mount
8. Bolt
9. Bolt

10. Bolt
11. Bolt (3/4 in. [19 mm] long)
12. Washer
13. Bolt (3-3/4 in. [95.25 mm] long)
14. Washers
15. Bolts (2-1/2 in. [63.5 mm] long)
16. Bolts
17. Bolts

CYLINDER STUDS

install the stud so the shoulder is properly positioned.

Replacement

Improper stud replacement can cause oil leaks. If all of the tools required to install the studs are not available, have a dealership install the studs.

NOTE

Later 1987-2003 models are equipped with cylinder studs that have a shoulder. Be sure to

1986-1994 models

1. If the engine is assembled, stuff some clean shop rags into the crankcase opening to prevent debris from falling into the engine.
2. Remove the damaged stud using a stud remover (Chapter One).

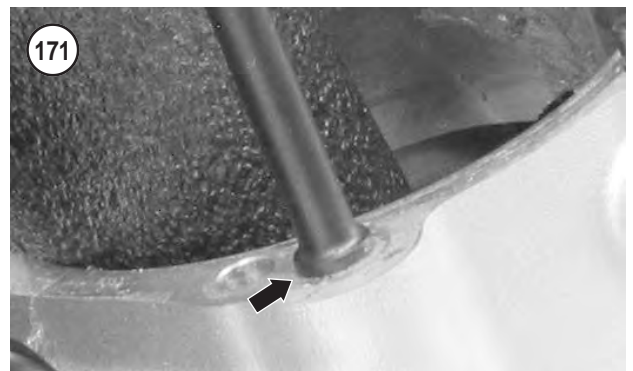
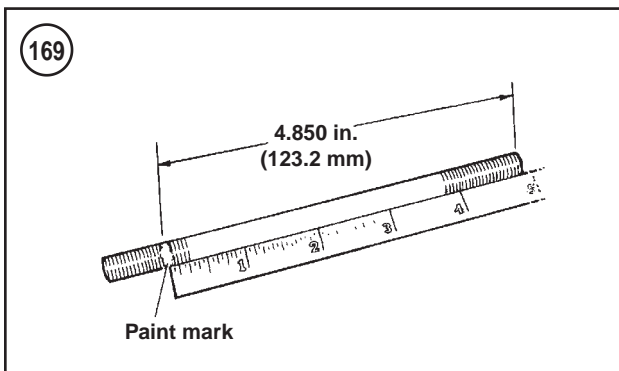

3. Clean the crankcase threads and the new stud with solvent or contact cleaner. Blow dry.
4. Measuring from the top of the stud, paint a mark that is 4.850 in. (123.2 mm) down the stud (**Figure 169**).
5. Drop a small steel ball (part No. 8860) into a cylinder head bolt and thread the bolt onto the top of the new stud.
6. Hand-thread the new stud into the crankcase, then install it with an air driver until the paint mark on the stud aligns with the crankcase base gasket surface.
7. Remove the cylinder head bolt and steel ball from the cylinder stud.
8. Measure the stud installed height (**Figure 170**). The stud installed height should be 4.770-4.870 in. (121.2-123.7 mm).
9. Place a protective hose around the stud.
10. Repeat Steps 2-9 for each stud.

1995-2003 models

1. If the engine is assembled, stuff some clean shop rags into the crankcase opening to prevent debris from falling into the engine.
2. Remove the damaged stud with a stud remover (Chapter One).
3. Clean the crankcase threads and the new stud with solvent or contact cleaner. Blow dry.

NOTE

The cylinder studs have a shoulder on the lower end (**Figure 171**).

4. Drop a small steel ball (part No. 8860) into a cylinder head bolt and thread the bolt onto the top of the new stud.
5. Hand-thread the new stud into the crankcase, then install it with an air driver until the shoulder on the stud contacts the crankcase base gasket surface.
6. Tighten the stud to 120 in.-lb. (14 N•m).
7. Remove the cylinder head bolt and steel ball from the cylinder stud.
8. Place a protective hose around the stud.
9. Repeat Steps 2-8 for each stud.

ENGINE BREAK-IN

If the engine is new, or following cylinder service such as boring, honing and installing new rings, or major lower end work, engine break-in is required.

1. For the first 50 mi. (80 km), maintain engine speed below 2500 rpm in any gear. However, do not lug the engine. Do not exceed 50 mph during this period.
2. From 50-500 mi. (80-804 km), vary the engine speed. Avoid prolonged steady running at one engine speed. During this period, increase engine speed to 3000 rpm. Do not exceed 55 mph.
3. After the first 500 mi. (804 km), the engine break-in is complete.

Table 1 ENGINE SERVICE SPECIFICATIONS

| | New in. (mm) | Service limit in. (mm) |
|--|------------------------------------|-----------------------------------|
| Tappets | | |
| Guide clearance | 0.0008-0.0023 (0.020-0.058) | 0.003 (0.076) |
| Roller fit | 0.0006-0.0013 (0.015-0.033) | — |
| Roller end clearance | 0.008-0.022 (0.203-0.559) | 0.026 (0.66) |
| Oil Pump | | |
| 1986-1990 models | | |
| Feed and scavenge outer to inner rotor clearance | 0.003 (0.076) | 0.004 (0.102) |
| Shaft-to-bushing clearance | 0.0025 (0.0635) | |
| Feed gear height above cover | 0.001-0.011 (0.025-0.279) | |
| 1991-2003 models | | |
| Shaft-to-pump clearance | 0.0025 (0.064) | — |
| Feed/scavenge inner/outer rotor clearance | 0.003 (0.08) | 0.004 (0.102) |
| Gearcase | | |
| Cam gear shaft bushing clearance | 0.0007-0.0022 (0.018-0.056) | 0.003 (0.076) |
| Cam gear shaft end play (minimum) | | |
| 1986-1990 models | | |
| Rear intake cam gear | 0.001-0.035 (0.025-0.127) | 0.040 (0.127) |
| All other cam gears | 0.0005-0.0215 (0.0127-0.5461) | 0.025 (0.635) |
| 1991-2003 models | | |
| Rear intake cam gear | 0.006-0.024 (0.15-0.61) | 0.040 (1.016) |
| All other cam gears | 0.005-0.024 (0.13-0.61) | 0.025 (0.635) |
| Cam gear needle bearing journal diameter | | |
| 1986-1990 models | 0.6865-0.6860 (17.437-17.424) | 0.6858 (17.419) |
| Connecting rods | | |
| Side play @ crankshaft | 0.005-0.025 (0.13-0.64) | 0.030 (0.762) |
| Piston pin fit (clearance) | 0.00125-0.00175 (0.0318-0.0445) | 0.002 (0.051) |
| Fit on crankpin | | |
| Early 1986 models | | |
| | 0.0003-0.0015 (0.0076-0.0381) | 0.002 (0.051) |
| Late 1986-2003 models | | |
| | 0.0004-0.0017 (0.010-0.043) | 0.0027 (0.0686) |
| Crankshaft | | |
| Runout @ flywheel rim | 0.000-0.010 (0.00-0.25) | 0.010 (0.25) |
| Runout @ shaft | 0.000-0.002 (0.00-0.051) | 0.002 (0.051) |
| End play | 0.001-0.005 (0.025-0.127) | 0.005 (0.127) |
| Sprocket shaft bearing | | |
| Outer race fit in crankcase (interference) | 0.0004-0.0024 (0.010-0.061) | — |
| Bearing inner race fit on crankshaft (interference) | 0.0002-0.0015 (0.005-0.038) | — |

(continued)

Table 1 ENGINE SERVICE SPECIFICATIONS (continued)

| | New in. (mm) | Service limit in. (mm) |
|--|------------------------------------|-----------------------------------|
| Pinion shaft bearing (1987-2003 models) | | |
| Outer race diameter in crankcase | 1.5646-1.5652 (39.741-39.756) | 1.5672 (39.807) |
| Fit in cover bushing | 0.0023-0.0043 (0.058-0.109) | 0.0050 (0.127) |
| Bearing running clearance | 0.00012-0.00088 (0.0030-0.0224) | – |
| Pinion shaft journal diameter | | |
| 1986 models | 1.2485-1.2490 (31.712-31.725) | 1.2483 (31.707) |
| 1987-2003 models | 1.2496-1.2500 (31.740-31.750) | 1.2494 (31.735) |

5

Table 2 FLYWHEEL END PLAY SHIM THICKNESS

| Harley-Davidson part number | in. | mm |
|------------------------------------|---------------|-------------|
| 9155 | 0.0975-0.0985 | 2.477-2.502 |
| 9142 | 0.0995-0.1005 | 2.527-2.553 |
| 9143 | 0.1015-0.1025 | 2.578-2.604 |
| 9144 | 0.1035-0.1045 | 2.629-2.654 |
| 9145 | 0.1055-0.1065 | 2.680-2.705 |
| 9146 | 0.1075-0.1085 | 2.731-2.756 |
| 9147 | 0.1095-0.1105 | 2.781-2.807 |
| 9148 | 0.1115-0.1125 | 2.832-2.856 |
| 9149 | 0.1135-0.1145 | 2.883-2.908 |

Table 3 ENGINE TORQUE SPECIFICATIONS

| | ft.-lb. | in.-lb. | N•m |
|---|----------------|----------------|------------|
| Crankcase bolts | | | |
| 1/4 in. | – | 70-110 | 8-12 |
| 5/16 in. | 16-18 | – | 21-24 |
| Cylinder head mounting bracket fasteners | | | |
| Engine mount-to-engine | 25-30 | – | 34-41 |
| Engine mount-to-frame | 30-35 | – | 41-47 |
| Engine center mount-to-engine | 28-35 | – | 38-47 |
| Cylinder stud (1995-2003 models) | – | 120 | 14 |
| Engine mount brackets | | | |
| Lower front | | | |
| Engine bolts | 25-30 | – | 34-41 |
| Frame bolts | 25-30 | – | 34-41 |
| Rear mount | | | |
| Frame to crankcase bolts | 25-30 | – | 34-41 |
| Upper front | | | |
| Engine bolts | 25-30 | – | 34-41 |
| Frame bolts | 30-35 | – | 41-47 |
| Top center | | | |
| Engine bolts | 25-30 | – | 34-41 |
| Frame bolts | 30-35 | – | 41-47 |
| Engine sprocket | | | |
| 1986-1998 models | 150-160 | – | 203-224 |
| 1999-2003 models | 190-210 | – | 258-285 |
| Gearcase cover screws | – | 80-110 | 9-12 |
| Oil filter adapter | – | 96-144 | 11-16 |
| Oil pressure switch ¹ | – | 60-70 | 7-8 |

(continued)

Table 3 ENGINE TORQUE SPECIFICATIONS (continued)

| | ft.-lb. | in.-lb. | N•m |
|--|----------------|----------------|------------|
| Oil pump assembly and mounting screws (1991-2003 models) | – | 125-150 | 14-17 |
| Oil pump cover screws | – | 70-80 | 7-9 |
| Oil pressure regulator plug ¹ | 15-20 | – | 20-27 |
| Oil pump mounting screws (1986-1990 models) | – | 90-110 | 10-12 |
| Pinion shaft nut ² | 35-45 | – | 47-61 |
| Tappet anti-rotation bolts (2000-2003 models) | – | 55-65 | 6-7 |
| Tappet guide bolts (1986-1990 models) | – | 96-168 | 11-19 |
| Tappet plate screws (1991-1999 models) | – | 80-110 | 9-12 |
| 1. Apply pipe sealant to the threads. 2. On 1988-2003 models, apply threadlock (Loctite 272 or equivalent). | | | |

CHAPTER SIX

PRIMARY DRIVE AND CLUTCH (1986-1990 MODELS)

This chapter covers the primary drive cover, primary drive, clutch assembly and clutch cable.

Table 1 and **Table 2** are at the end of the chapter.

PRIMARY DRIVE COVER

Refer to **Figure 1**.

Removal

1. Disconnect the negative battery cable (Chapter Twelve).
2. Drain the transmission oil (Chapter Three).
3. Remove the gearshift pedal and the left footpeg (Chapter Seventeen).
4. Loosen the locknut and unscrew the adjuster (A, **Figure 2**) to loosen the primary drive chain.
5. Remove the clutch inspection cover (B, **Figure 2**).
6. Remove the adjusting screw spring and lockplate (**Figure 3**).
7. Turn the clutch adjusting screw clockwise (**Figure 4**) until the nut can be removed, then remove the nut (**Figure 5**).

NOTE

Different length screws secure the primary drive cover. Note the location and length of the screws.

8. Remove the primary drive cover (C, **Figure 2**) and gasket.

9. If necessary, remove the dowel pins.

10. If necessary, service the following components as described in this chapter:

- a. Clutch mechanism adjuster
- b. Primary chain adjuster
- c. Shift shaft oil seal

Installation

1. Clean the primary drive cover and engine crankcase gasket surfaces in solvent and dry thoroughly.
2. If removed, install the clutch assembly and connect the clutch cable as described in this chapter.
3. Install the dowel pins, if removed.
4. Using a new gasket, install the primary drive cover onto the crankcase. Install the mounting screws and tighten to 80-110 in.-lb. (9-12 N•m).
5. Thread the nut (**Figure 5**) onto the clutch adjusting screw until the screw slot is accessible with a screwdriver. Then align and install the hex portion on the nut into the outer ramp recess. Turn the clutch adjusting screw (**Figure 4**) counterclockwise until the nut cannot be removed.

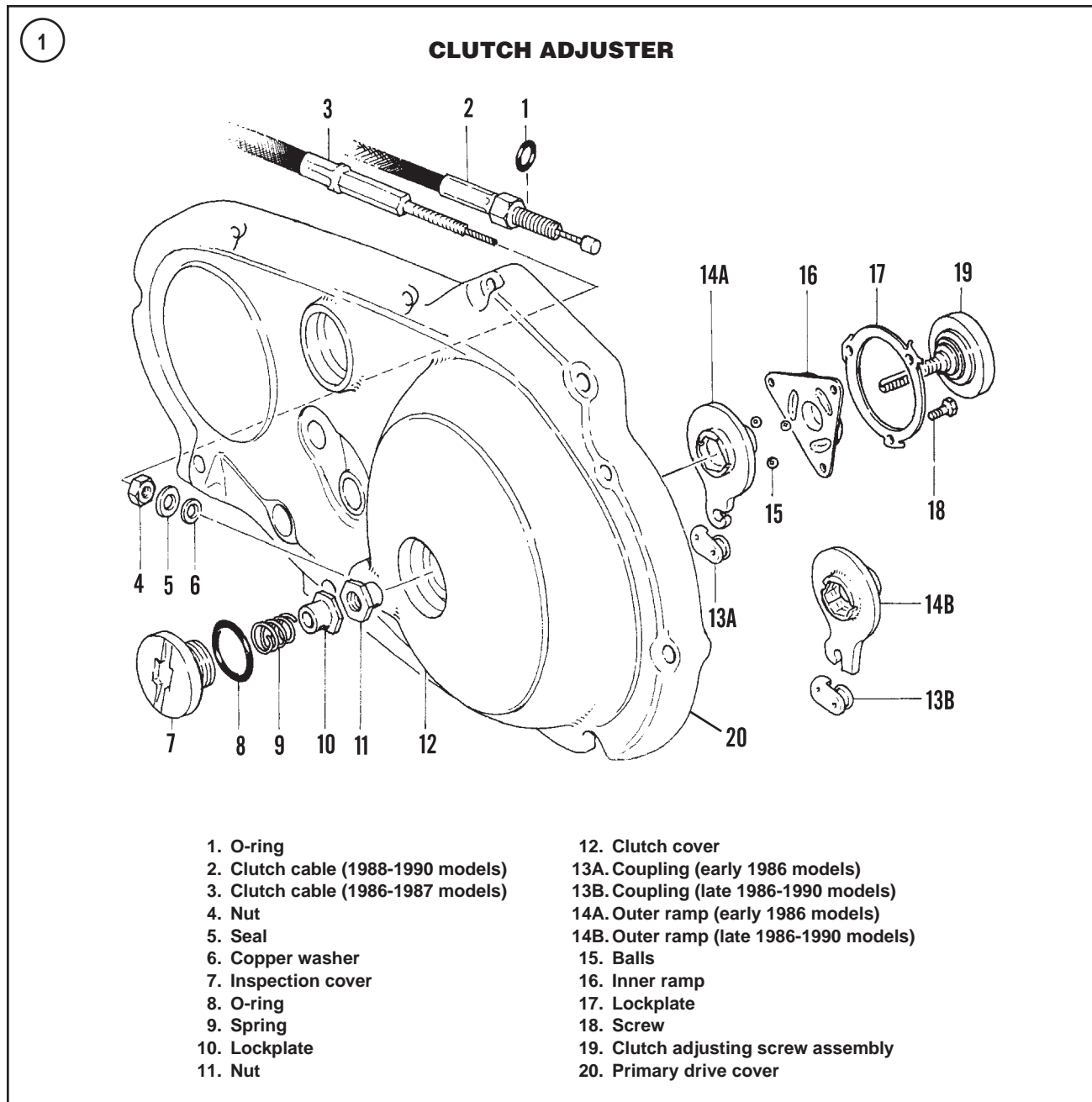

6. Adjust the clutch as described in Chapter Three. The spring and lockplate shown in **Figure 3** will be installed during the clutch adjustment procedure.
7. Adjust the primary chain (Chapter Three).
8. Refill the transmission oil (Chapter Three).
9. Install the shift lever and tighten the pinch bolt to 90-110 in.-lb. (10-12 N•m).
10. Install the left footpeg. Tighten the mounting bolts to 24-36 ft.-lb. (33-49 N•m).

CLUTCH RELEASE MECHANISM

Refer to **Figure 1**.

Removal

1. Remove the primary drive cover as described in this chapter.
2. Pry the lockplate tabs away from the mounting screws and remove the lockplate (A, **Figure 6**) and screws.
3. Remove the clutch release mechanism from the cover and disconnect the cable (B, **Figure 6**) from the ramp and coupling (C, **Figure 6**).

Inspection

1. Wash the clutch release mechanism in solvent and dry thoroughly.

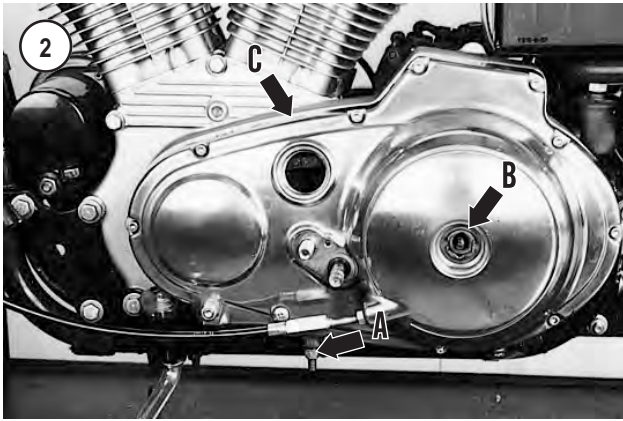

6



2. Check the balls and ramp sockets (**Figure 7**) for pitting, severe wear or other damage.
3. Check the adjusting screw (**Figure 8**) for thread or bearing damage.
4. Replace the lockplate if the tabs are weak or broken.
5. Replace worn or damaged parts as required.

Installation

NOTE

*The early 1986 coupling and outer ramp are not the same as later couplings or outer ramps. See **Figure 9**. A later coupling and*

outer ramp may be used in early engines, but both parts must be installed, not mixed with an early coupling or outer ramp.

1. Install the cable coupling onto the end of the clutch cable. Place the coupling in the ramp.
2. Apply grease to the ball and ramp surfaces (**Figure 7**) and insert the balls into the ramp sockets.
3. Assemble the inner and outer ramps and install on the primary drive cover (C, **Figure 6**). Install the lockplate and the ramp mounting screws. Tighten the screws securely. Bend the lockplate tabs over the screws to lock them in place.
4. Install the primary drive cover as described in this chapter.
5. Adjust the clutch as described in Chapter Three.

PRIMARY CHAIN ADJUSTER

Removal/Installation

Refer to **Figure 10**.

1. Remove the primary drive cover as described in this chapter.
2. Pull the chain pad (**Figure 11**), spring and washer from the stud.
3. Replace the chain pad if worn severely or cracked. Also check the carrier (3, **Figure 10**) and spring (2). Replace if necessary.
4. Install by reversing the preceding steps.
5. Adjust the clutch (Chapter Three).
6. Adjust the primary chain (Chapter Three).
7. Refill the primary case and transmission with oil (Chapter Three).

PRIMARY DRIVE/CLUTCH

Refer to **Figure 12**.

Special Tools

Complete disassembly of the clutch requires the use of a clutch spring compression tool (part No. 34761-84). If the compression tool is not available, remove the clutch intact from the motorcycle and take it to a dealership for disassembly and service. Do *not* attempt to disassemble the clutch without the special tool.

Clutch/Primary Chain/Engine Sprocket Removal (Clutch is Not Disassembled)

This procedure describes removal of the clutch, primary chain and engine sprocket, which allows later clutch disassembly as described in this section. If clutch disassembly with the clutch mounted on the motorcycle is desired, refer to *Clutch Disassembly on Motorcycle* in this section in this chapter.

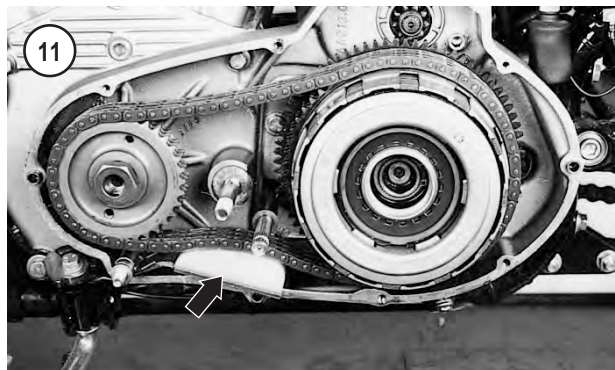
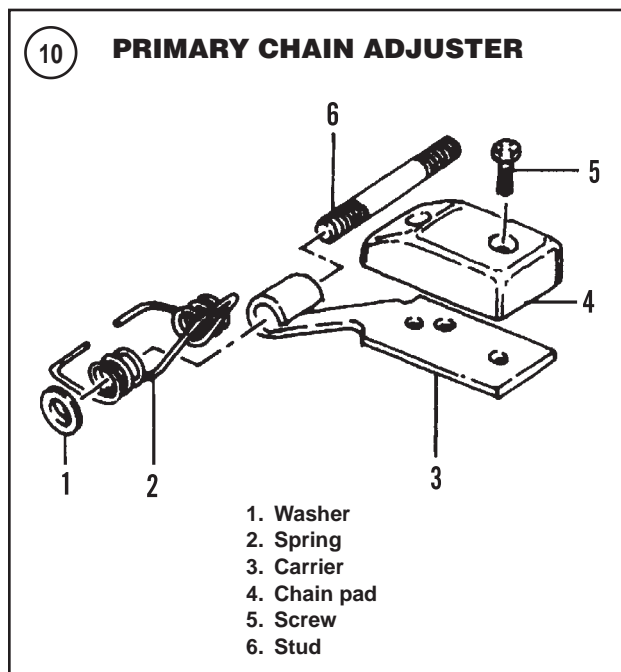
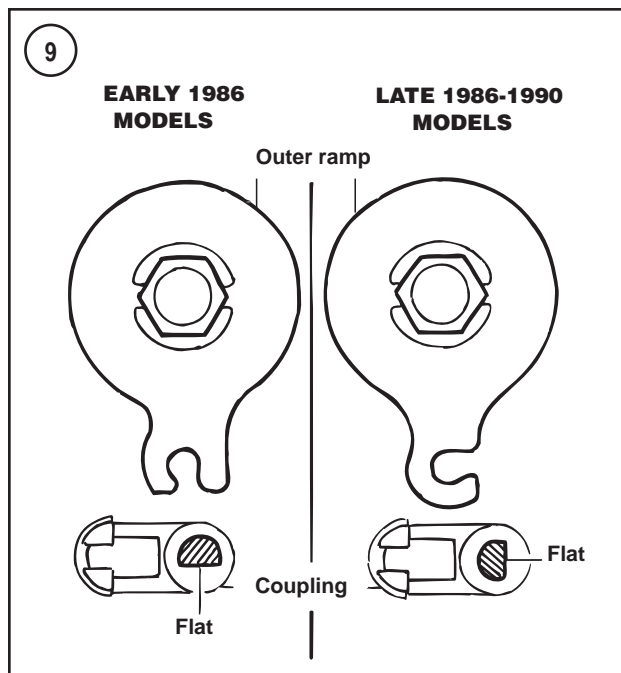

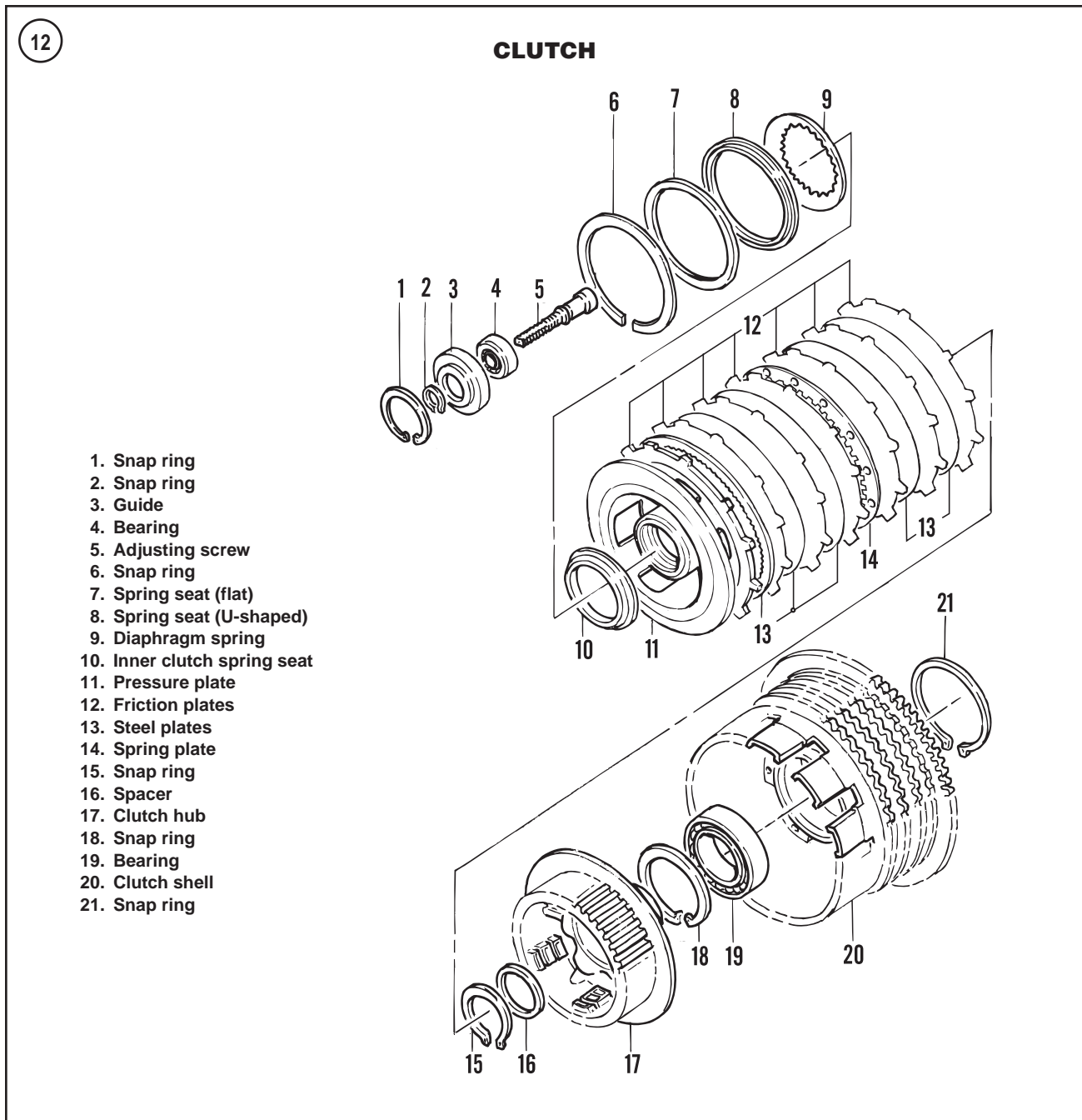

Refer to **Figure 12**.

1. Disconnect the negative battery cable (Chapter Twelve).
2. Remove the primary drive cover as described in this chapter.
3. Remove the clutch adjusting screw snap ring (**Figure 13**) and remove the guide and adjusting screw assembly (**Figure 14**).
4. Install a clutch holder (JIMS tool No. 2234 or equivalent) to prevent engine sprocket rotation, then remove the engine sprocket nut (A, **Figure 15**).
5. Remove the clutch snap ring (B, **Figure 15**) and spacer behind the snap ring. Remove the clutch assembly, primary chain and engine sprocket as an assembly.

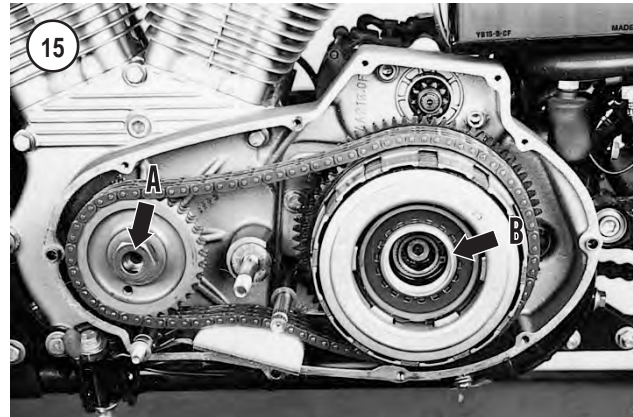

CAUTION

Do not attempt to disassemble the clutch assembly after removing it from the motorcycle. The clutch must be disassembled while mounted on the engine.

6. Installation is the reverse of removal while noting the following:
 - a. Apply threadlock (Loctite 242 or equivalent) to the sprocket shaft threads.
 - b. Tighten the engine sprocket nut to 150-165 ft.-lb. (203-223 N•m).
 - c. Adjust the primary chain (Chapter Three).

Clutch Disassembly on Motorcycle

This procedure describes disassembly of the clutch and clutch plate removal while it is mounted on the motorcycle. Engine sprocket and primary chain removal is not required. Read this procedure completely before starting disassembly.

1. Disconnect the negative battery cable (Chapter Twelve).
2. Remove the primary drive cover as described in this chapter.

WARNING

*Do not attempt to disassemble the clutch assembly without the use of a clutch spring compression tool (part No. 34761-84). The diaphragm spring (6, **Figure 12**) is held under considerable pressure and will fly out if pressure is not first removed.*

3. Install the spring compression tool onto the clutch assembly (**Figure 16**). Secure the compression tool per the manufacturer's instructions.
4. Turn the adjusting screw counterclockwise until the compression tool releases the pressure on the snap ring (**Figure 16**). Remove the snap ring. Remove the nut and compression tool.
5. Refer to **Figure 12**. Disassemble the clutch housing by removing the following parts in order:
 - a. Adjusting screw assembly (**Figure 14**).
 - b. Outer clutch spring seats (**Figure 17**).
 - c. Diaphragm spring (**Figure 18**).

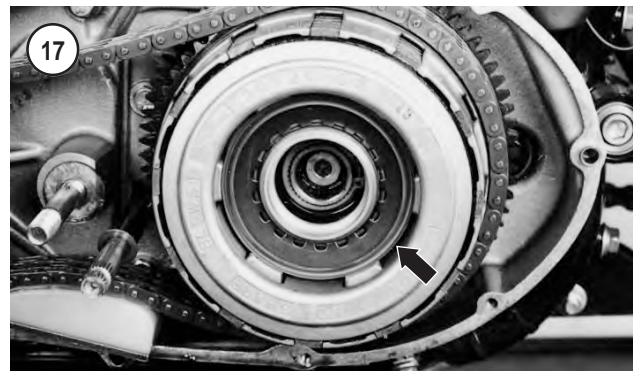
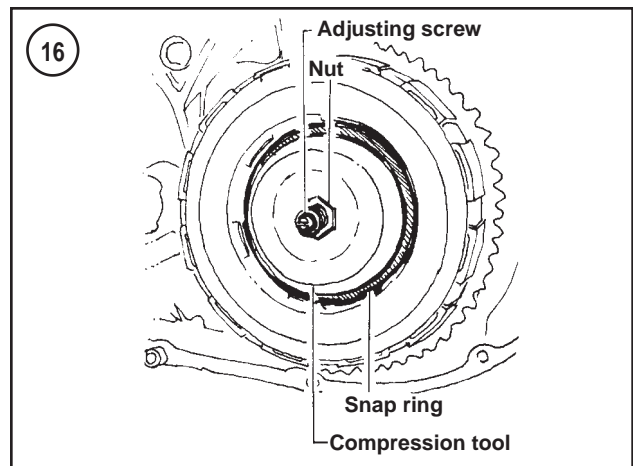

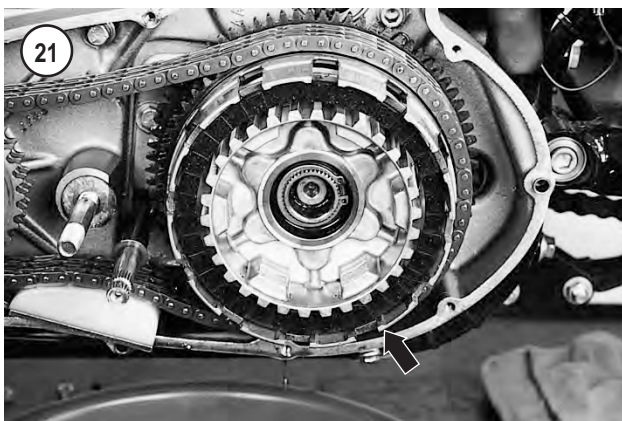
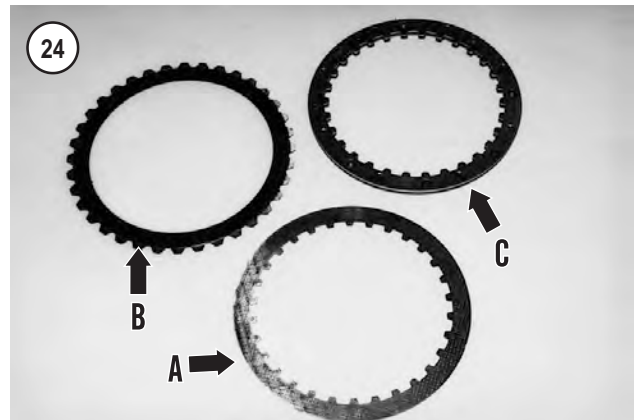
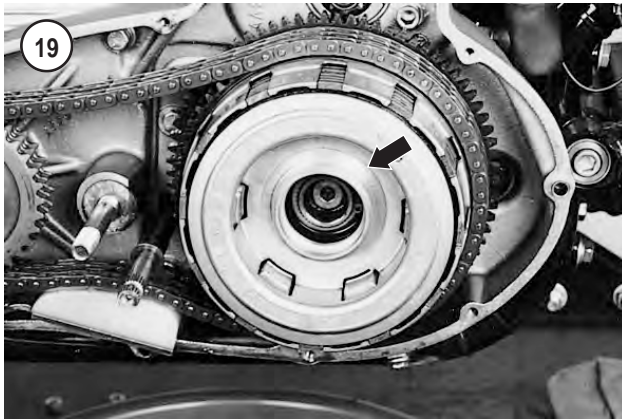

- d. Inner clutch spring seat (Figure 19).
- e. Pressure plate (Figure 20).
6. Remove four friction plates (Figure 21) and three steel plates (Figure 22).
7. Remove the spring plate (Figure 23).
8. Remove the remaining friction and steel plates in the order shown in Figure 12.

NOTE

Further removal steps are not required unless it is necessary to separate the clutch hub and shell assembly. Remove these parts as described in this section.

Clutch Inspection

Refer to Figure 12.

1. Clean all parts, except friction and steel plates and bearings, in a non-oil based solvent and thoroughly dry with compressed air. Place all cleaned parts on lint-free paper towels.
2. Inspect the steel plates (A, Figure 24) for warp as shown in Figure 25. Also measure the thickness of each plate. Replace all clutch plates; if any one plate is warped excessively or is too thin. Refer to Table 1.
3. Inspect the friction plates (B, Figure 24) for wear or surface damage. Measure the thickness of each plate (Figure 26) and compare to specifications in Table 1. If a plate's thickness is within specifications but the oil grooves are worn flush with the plate, replace the plates. Also check the friction plates for

warp (**Figure 27**) and compare to the service limit in **Table 1**. Replace all friction plates if any one plate is too thin or warped excessively.

4. Inspect the spring plate (C, **Figure 24**) for cracks or damage. Check for loose or damaged rivets. Replace the spring plate if necessary.

5. Check the diaphragm spring for cracks or damage. Check also for bent or damaged tabs. Replace the diaphragm spring if necessary.

6. A ball bearing is pressed into the clutch shell and the clutch hub is pressed into the bearing. Hold the clutch hub and rotate the clutch shell by hand. The shell should turn smoothly with no sign of roughness or tightness. If the clutch shell binds or turns roughly, the bearing is damaged and must be replaced. Refer to Step 10.

7. The steel plate inner teeth mesh with the clutch hub splines. Check the splines for cracks or galling. They must be smooth for chatter-free clutch operation. If the clutch hub splines are damaged, the clutch hub must be replaced; refer to Step 10.

8. The friction plates (B, **Figure 24**) have tabs that slide in the clutch shell grooves. Inspect the shell grooves for cracks or wear grooves. The grooves must be smooth for chatter-free clutch operation. If the clutch shell grooves are damaged or worn severely, replace the clutch shell; refer to Step 10.

9. Check the primary chain sprocket and the starter ring gear on the clutch shell for cracks, deep scoring, excessive wear or heat discoloration. If either the sprocket or ring gear is severely worn or damaged, replace the clutch shell; refer to Step 10. If the sprocket is worn, also check the primary chain and the engine sprocket as described in this chapter.

10. If the clutch hub, shell or bearing require replacement, refer to *Clutch Hub and Shell Disassembly/Reassembly* in this section.

Primary Chain

Replace the primary chain if severely worn or damaged. Do not attempt to repair the chain. If the primary chain is worn or damaged, check the engine sprocket and clutch shell sprocket for wear or damage. Replace parts as required.

Adjust the primary chain as described in Chapter Three.

Clutch Hub and Shell Disassembly/Reassembly

1. Remove the clutch plates from the clutch hub and shell assembly, if they have not been previously removed. Refer to *Clutch Disassembly on Motorcycle* in this section.
2. Remove the snap ring from the clutch hub groove (**Figure 28**).

CAUTION

If it is necessary to press or drive the clutch hub out of the shell bearing, the bearing will be damaged and must be replaced.

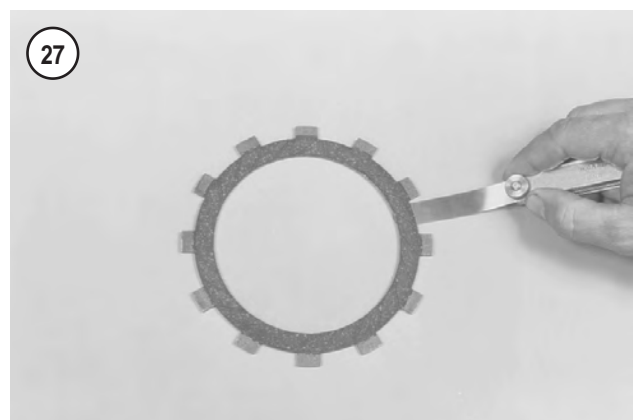
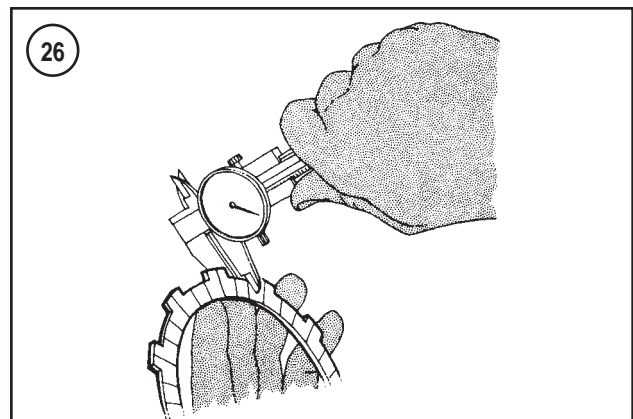
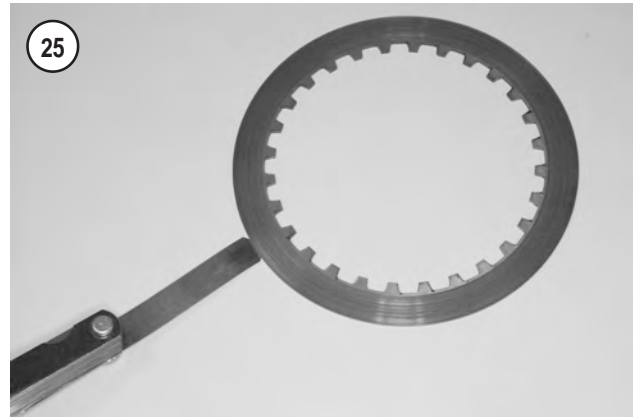

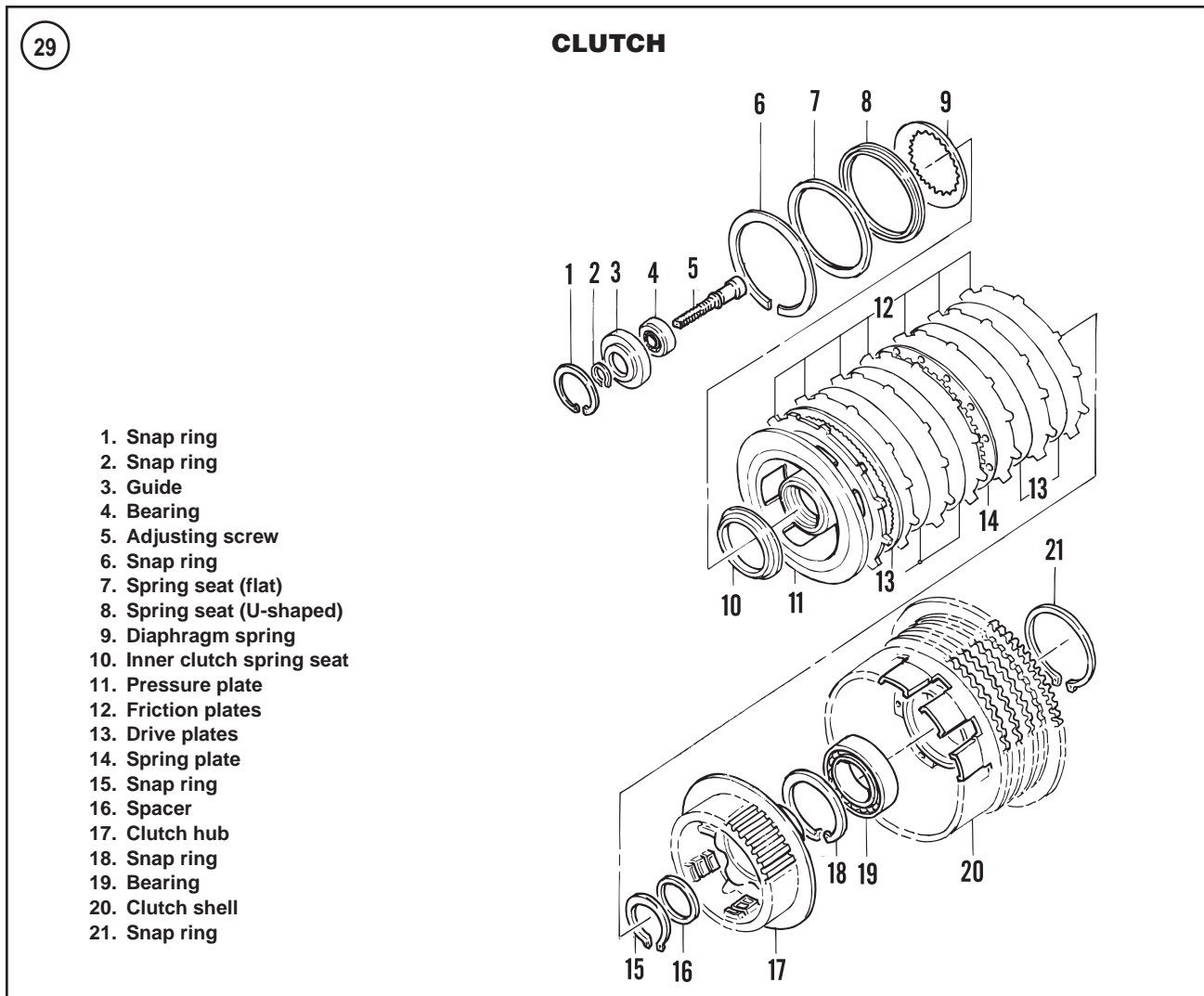

3. Remove the clutch hub from the clutch shell bearing.
4. Locate the snap ring securing the bearing in the clutch shell. Remove the snap ring from the clutch shell groove.
5. Support the clutch shell in a press and press the bearing out of the shell. The bearing must be removed through the front side of the shell. The clutch shell is manufactured with a shoulder on the rear (primary chain) side. Discard the bearing.
6. Discard worn or damaged parts. Clean reusable and new parts, except bearings and snap rings, in a non-oil based solvent and dry thoroughly.
7. Place the clutch shell into the press. Then align the bearing with the clutch shell and press the bearing into the shell until the bearing bottoms against the lower shoulder. When pressing the bearing into the clutch shell, press only on the outer bearing race. Installing the bearing by pressing on its inner race will damage the bearing. Refer to *Service Methods* in Chapter One.
8. Install a new snap ring into the clutch shell groove. Make sure the snap ring seats in the groove completely.
9. Install the clutch hub into the clutch shell bearing. If pressing is required to install the clutch hub into the clutch shell, be sure to support the bearing inner race.

10. Install a new clutch hub snap ring (**Figure 28**). Make sure the snap ring seats in the clutch hub groove completely.

11. After completing assembly, hold the clutch hub and rotate the clutch shell by hand. The shell should turn smoothly with no roughness or binding. If the clutch shell binds or turns roughly, the bearing may have been damaged during reassembly. Correct before installation

Clutch Assembly

If the clutch assembly was not disassembled, refer to *Clutch Installation* in this section.

Before installing the clutch plates, count the number of each plate. The set should include seven friction plates, five drive plates and one spring plate.

Refer to **Figure 29**.

1. Soak all of the clutch plates in clean transmission oil for approximately 5 minutes before installing them.
2. Align the tabs on a friction plate with the clutch shell grooves and install the plate. Then align the inner teeth on

a drive plate with the clutch hub grooves and install the plate. Repeat until all of the clutch plates have been installed. Install the spring plate between the third and fourth friction plates. The last plate installed must be a friction plate.

NOTE

During clutch removal, if the spring compressing tool was not removed from the diaphragm spring and pressure plate, proceed to Step 4. If the spring compressing tool was removed and the diaphragm spring was separated from the pressure plate, continue with Step 3.

3. Assemble the pressure plate and diaphragm spring as follows:

- a. Install the adjusting screw assembly (release plate, snap ring, bearing and adjusting screw) into the pressure plate. Install the release plate by aligning its tabs with the slots in the pressure plate. Secure the release plate by installing the retaining ring into the pressure plate groove. Make sure the retaining ring seats in the groove completely.
- b. The diaphragm spring is concave. Install the diaphragm spring onto the pressure plate so the concave side faces the pressure plate—the convex side must face out.
- c. Install the spring seat with its flat, larger outer diameter side facing toward the diaphragm spring.

WARNING

*A clutch spring compression tool (part No. 34761-84), is required to install the diaphragm spring (9, **Figure 29**). Severe personal injury from the diaphragm spring flying out could occur if the special tool is not used.*

4. To install the diaphragm spring snap ring, use a clutch spring compression tool to perform the following:

- a. Install the clutch spring compression tool onto the clutch assembly (**Figure 30**). Secure the spring compression tool per the manufacturer's instructions.
- b. Position the spring compression tool against the diaphragm spring and thread the tool handle onto the end of the forcing screw. Do not apply pressure against the diaphragm spring at this time.

CAUTION

Turn the compression tool nut only the amount required to compress the diaphragm spring and install the snap ring. Excessive compression of the diaphragm spring may damage the clutch pressure plate.

- c. Turn the compression tool nut clockwise to compress the diaphragm spring.

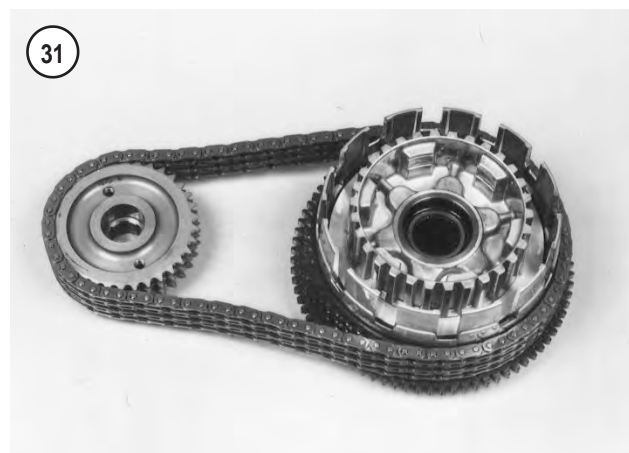
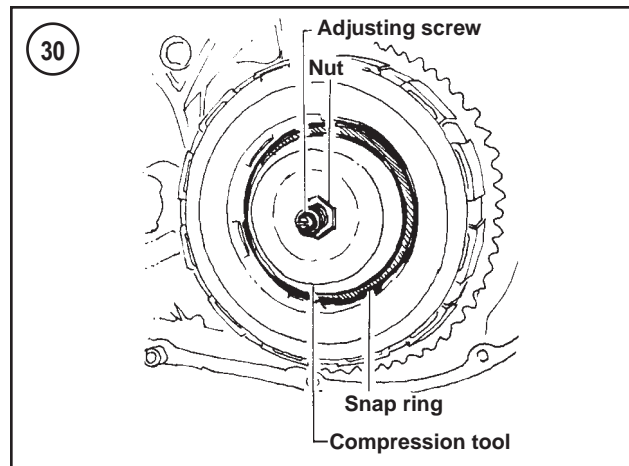

- d. Install the spring seat and snap ring into the groove in the clutch hub prongs.
- e. After making sure the snap ring is seated completely in the clutch hub groove, slowly turn the compressing tool handle counterclockwise while checking that the clutch spring seat lip seats against the snap ring. After all tension has been removed from the compressing tool, remove it from the release plate.

5. Remove the release plate retaining ring. Then remove the adjusting screw assembly.

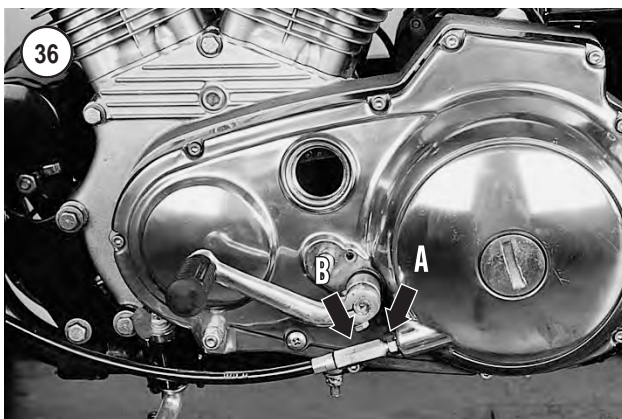
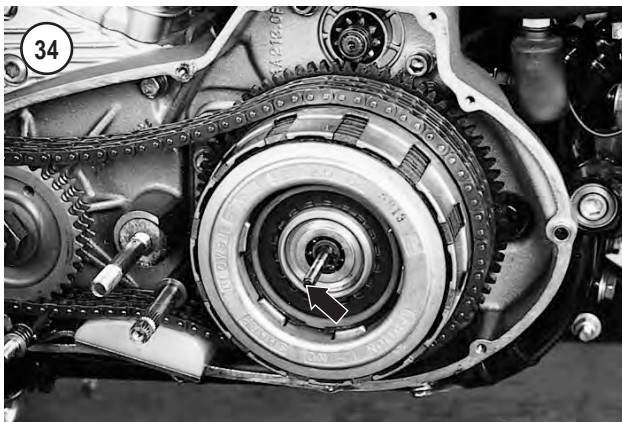
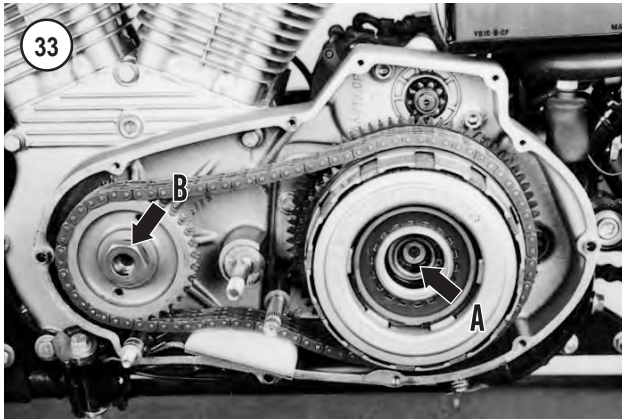

Clutch Installation

1. Assemble the clutch assembly as described in this section.
2. The engine sprocket, primary chain and clutch are installed as an assembly. Assemble the engine sprocket, clutch and primary chain as shown in **Figure 31**.

CAUTION

The alternator rotor is mounted on the clutch shell (**Figure 32**). Inspect the inside of the rotor for small bolts, washers or other metal debris picked up by the magnets. These metal pieces damage the alternator stator assembly.

3. Lift the primary drive assembly as a unit and slide the engine sprocket and clutch into the primary chaincase (**Figure 33**).
4. Install the spacer and the clutch circlip (A, **Figure 33**) and spacer behind the circlip.
5. Use a sprocket locking tool to prevent engine sprocket rotation.

CAUTION

The engine sprocket is tightened to a high torque specification. Be sure to hold the sprocket securely when tightening the nut.

6. Apply of threadlock (Loctite 242 or equivalent) to the engine sprocket nut threads and then install the engine sprocket nut (B, **Figure 33**). Tighten the sprocket nut to 150-165 ft.-lb. (203-223 N•m).
7. Remove the sprocket locking tool.
8. Install the adjusting screw assembly (**Figure 34**) by aligning the two tabs on the release plate perimeter with the two recesses in the pressure plate.
9. Install a new snap ring (**Figure 35**).
10. Install the primary drive cover as described in this chapter.
11. Adjust the primary chain (Chapter Three).
12. Refill the primary chain housing with the correct type and quantity oil (Chapter Three).
13. Reconnect the negative battery cable (Chapter Twelve).

CLUTCH CABLE

Replacement

Refer to **Figure 1** and **Figures 36-38**.

- 1A. On 1986-1987 models, loosen the clutch cable jam nut (A, **Figure 36**) and turn the adjuster (B) to provide maximum cable slack.
- 1B. On 1988-1990 models, slide the rubber boot off the clutch in-line cable adjuster. Loosen the adjuster jam nut (A, **Figure 37**) and turn the adjuster (B) to provide maximum cable slack.

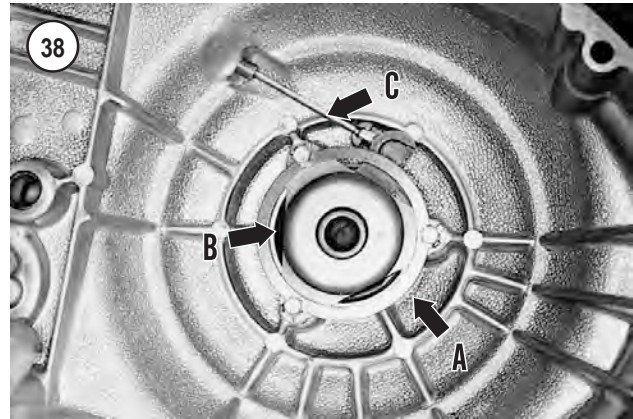
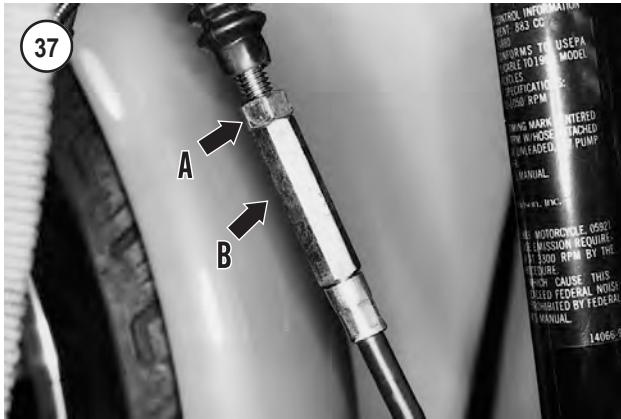

2. Remove the primary drive cover as described in this chapter.
3. Pry the lockplate tabs away from the mounting screws and remove the lockplate (A, **Figure 38**) and screws.
4. Remove the clutch release mechanism (B, **Figure 38**) from the cover and disconnect the cable (C) from the ramp and coupling. Hold the ramps together to prevent the balls from falling out.
5. Turn the lower clutch cable fitting and unscrew it from the primary drive cover.
6. At the clutch lever, remove the pivot pin circlip and remove the pivot pin.
7. Disengage the clutch lever from the handlebar bracket.
8. Disengage the cable end from the fitting in the clutch lever.
9. Note the routing of the clutch cable and the position of all cable clamps, then remove the clutch cable.
10. If necessary, remove the screw and anti-rattle spring from the bottom of the clutch lever.
11. Inspect the bushing(s) in the control lever bracket. Replace if damaged or worn.
12. Inspect the pivot pin and replace if damaged or worn.
13. Inspect the cable retaining pin. Replace it if damaged or worn.
14. Install the clutch cable by reversing the removal steps while noting the following:



- a. On 1988-1990 models, install a new O-ring on the end of the lower cable housing fitting (**Figure 39**).
- b. Install the lower cable housing fitting and tighten to 36-60 in.-lb. (4-7 N•m).
- c. Connect the cable coupling to the outer ramp. Install the clutch release mechanism and lockplate. Tighten the screws securely and bend the lockplate tabs over the screws to lock them.
- d. Adjust the clutch (Chapter Three).

Table 1 CLUTCH SPECIFICATIONS

| | New in. (mm) | Service limit in. (mm) |
|---------------------------------|----------------------------------|-----------------------------------|
| Friction plate thickness | 0.1469-0.1531 (3.731-3.889) | 0.130 (3.30) |
| Steel plate thickness | 0.0609-0.0649 (1.5469-1.6485) | 0.060 (1.524) |
| Warp | — | 0.010 (0.25) |

Table 2 CLUTCH TORQUE SPECIFICATIONS

| | ft.-lb. | in.-lb. | N•m |
|--|----------------|----------------|------------|
| Cable housing fitting | – | 36-60 | 4-7 |
| Engine sprocket nut* | 150-165 | – | 203-223 |
| Left footpeg | 24-36 | – | 33-49 |
| Primary drive chain cover mounting screws | – | 80-110 | 9-12 |
| Shift lever pinch bolt | – | 90-110 | 10-12 |
| *Apply threadlock (Loctite 242 or equivalent). | | | |

CHAPTER SEVEN

PRIMARY DRIVE AND CLUTCH (1991-2003 MODELS)

This chapter covers the primary drive cover, primary drive, clutch assembly and clutch cable.

Table 1 and **Table 2** are at the end of the chapter.

PRIMARY DRIVE COVER (1991-1993 MODELS)

Refer to **Figure 1**.

Removal

1. Disconnect the negative battery cable (Chapter Twelve).
2. Remove the transmission oil drain plug (**Figure 2**) and drain the transmission (Chapter Three).
3. Loosen the locknut (A, **Figure 3**) and turn the primary chain adjuster screw (B) to loosen the chain.
4. Remove the clutch inspection cover (**Figure 4**).
5. Remove the spring and lockplate (**Figure 5**).
6. Turn the clutch adjusting screw clockwise (**Figure 6**) until the nut can be removed, then remove the nut (**Figure 7**).
7. Remove the shift lever and left footpeg assembly (**Figure 8**) as described in Chapter Seventeen.
8. Remove the primary drive cover (**Figure 9**) and gasket. The primary drive cover is retained by different length screws (**Figure 10**). Create a drawing on cardboard in the

shape of the cover, then punch each screw through the cardboard at its location.

9. Remove the dowel pins (**Figure 11**), if necessary.
10. If necessary, remove the clutch mechanism as described in this chapter.
11. If necessary, service the following components as described in this chapter:
 - a. Clutch release mechanism.
 - b. Primary chain adjuster.
 - c. Shift shaft oil seal.

Installation

1. Clean the primary drive cover and engine crankcase gasket surfaces and dry thoroughly.
2. Clean the magnetic drain plug and reinstall it into the primary drive cover. Tighten the drain plug to 14-21 ft.-lb. (19-28 N•m).
3. Assemble the clutch release mechanism and connect the clutch cable as described in this chapter.
4. Install the dowel pins (**Figure 11**), if removed.
5. Using a new gasket, install the primary chain cover onto the crankcase. Install the cover mounting screws into their correct locations, as noted during removal, and tighten them in a crisscross pattern to 80-110 in.-lb. (9-12 N•m).

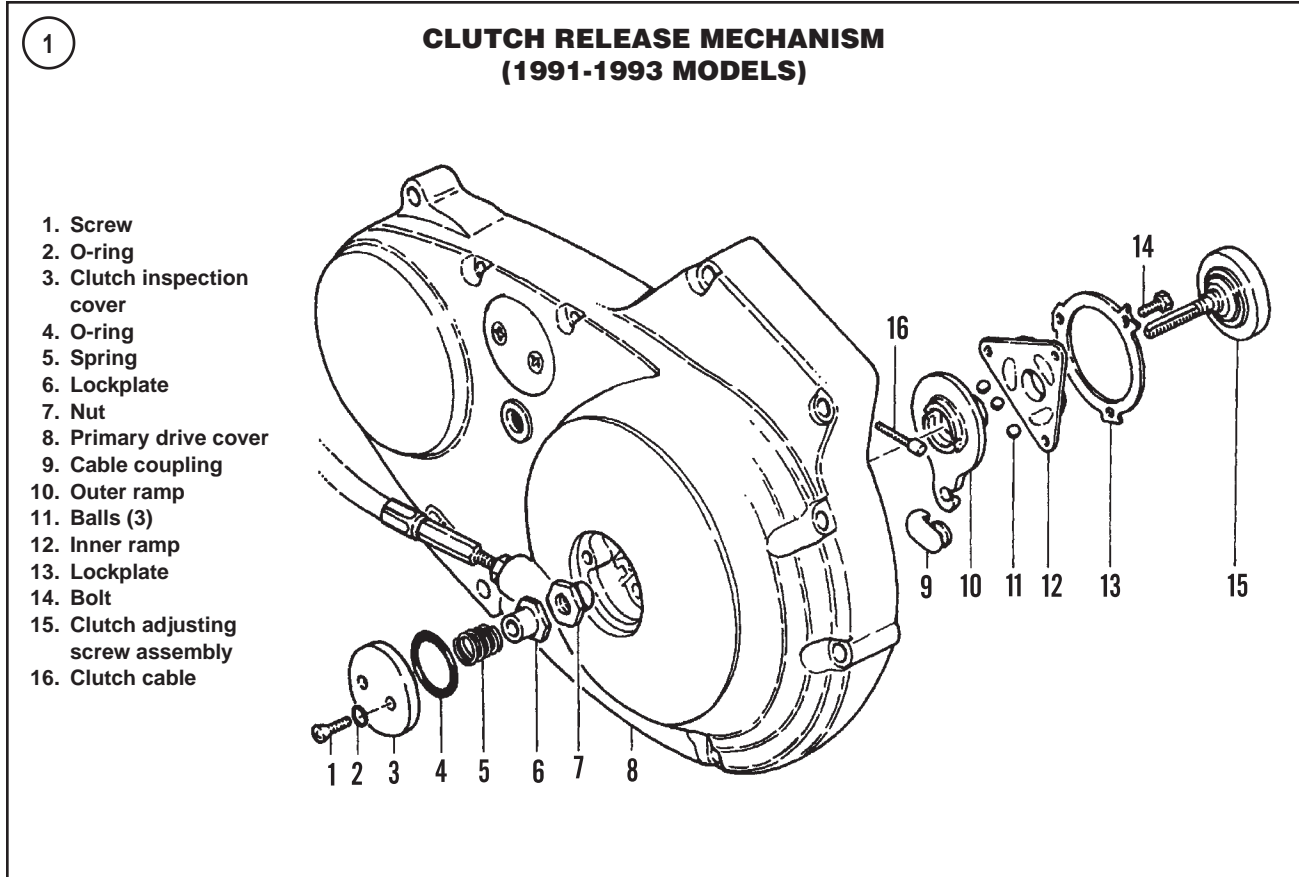

7

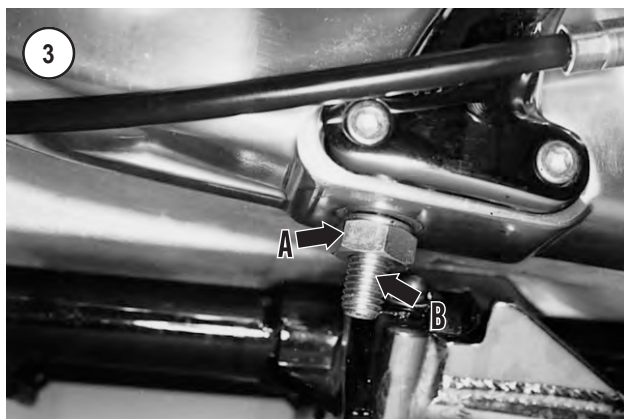
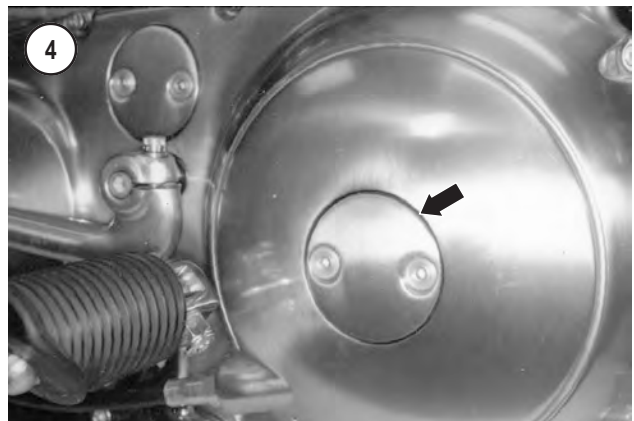

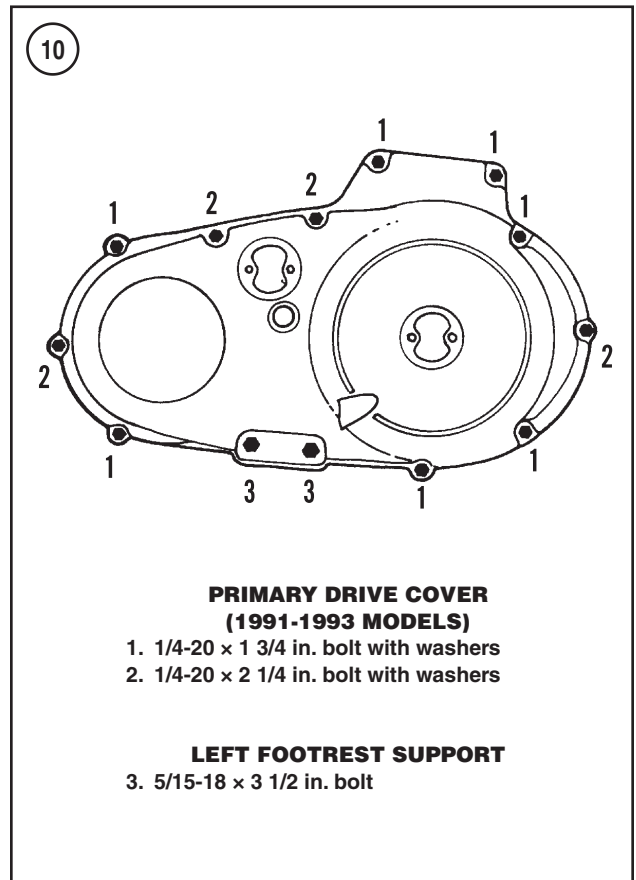

6. Thread the nut (**Figure 7**) onto the clutch adjusting screw until the screw slot is accessible with a screwdriver. Then align and install the hex portion of the nut into the outer ramp recess. Turn the clutch adjusting screw (**Figure 6**) until the nut cannot be removed.

7. Adjust the clutch (Chapter Three). The spring and lockplate shown in **Figure 5** will be installed during the clutch adjustment procedure.

8. Adjust the primary chain (Chapter Three).

9. Refill the transmission oil (Chapter Three).

10. Install the shift lever (**Figure 8**) and tighten the pinch bolt to 80-110 in.-lb. (9-12 N•m).

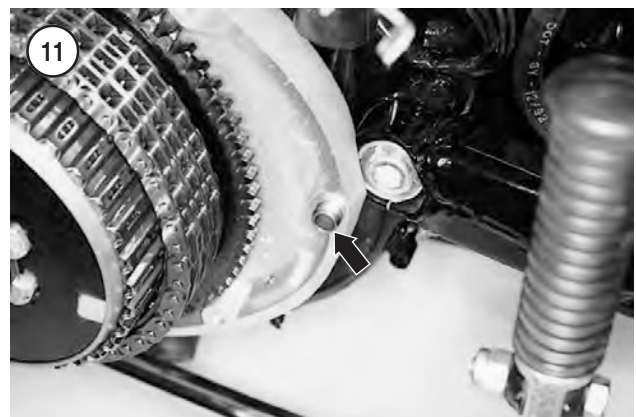

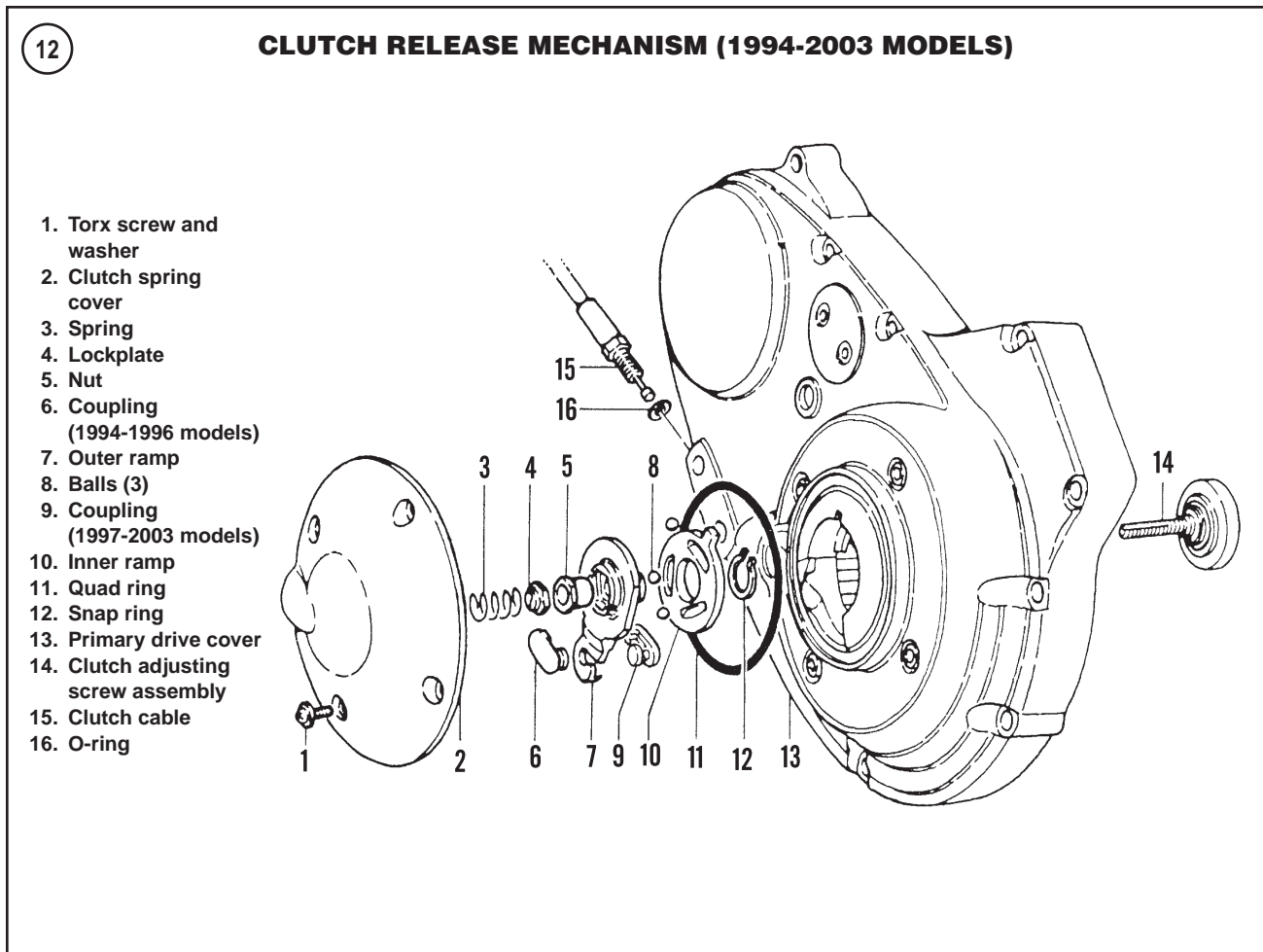

7

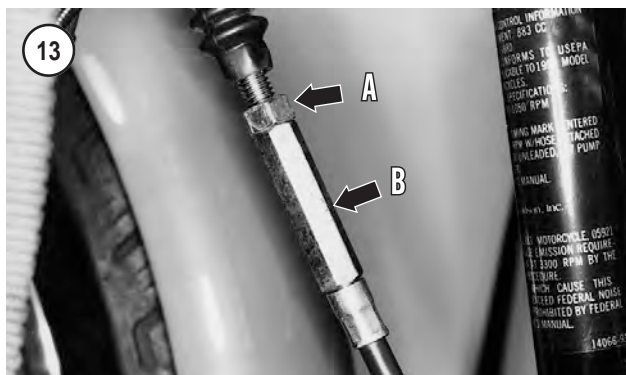

PRIMARY DRIVE COVER (1994-2003)

Refer to **Figure 12**.

Removal

1. Disconnect the negative battery cable (Chapter Twelve).
2. Remove the left side footrest assembly (Chapter Seventeen).
3. Drain the transmission oil (Chapter Three).
4. Loosen the locknut (A, **Figure 13**) and turn the primary chain adjuster screw (B) to loosen the chain.
5. Slide the rubber boot off the clutch in-line cable adjuster.
6. Loosen the adjuster jam nut (A, **Figure 13**) and turn the adjuster (B) to provide maximum cable slack.
7. Remove the clutch inspection cover.
8. Remove the quad ring (A, **Figure 14**).
9. Remove the spring and lockplate (B, **Figure 14**).
10. Turn the clutch adjusting screw (A, **Figure 15**) clockwise and release the ramp (B) and coupling (C). Turn the clutch adjusting screw clockwise to move the ramp assembly forward. Then unscrew the nut (D, **Figure 15**) from the end of the adjusting screw and remove it.

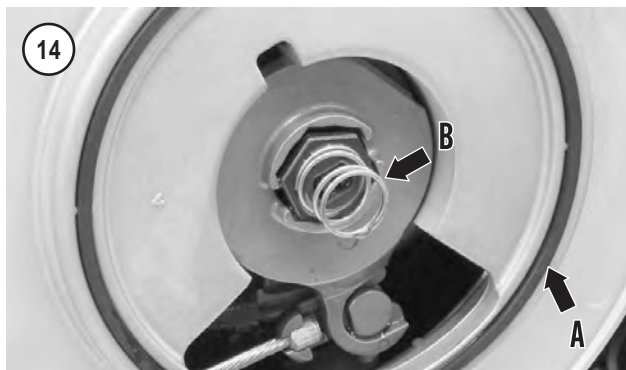

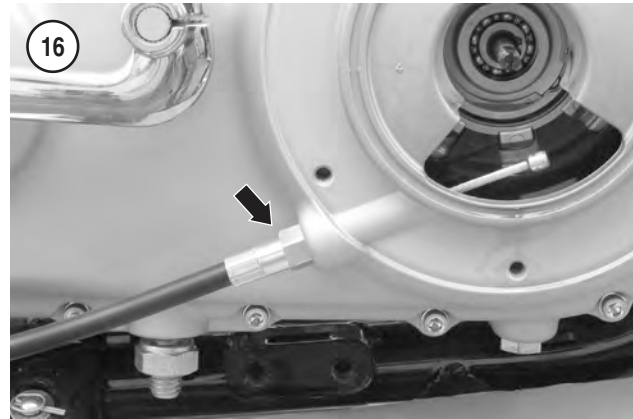
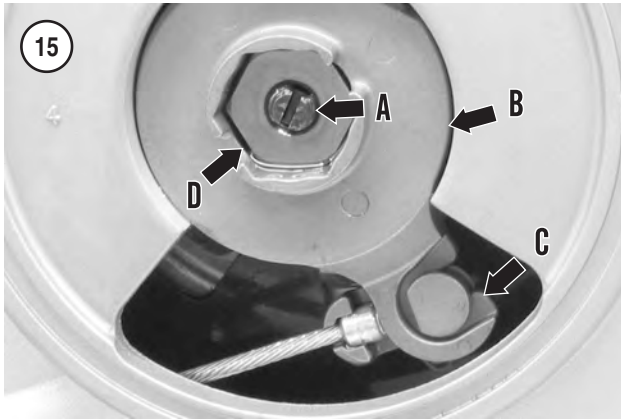

11. Pivot the hook on the ramp to the rear of the cable end coupling. Then disconnect and remove the clutch cable from the slot in the coupling. Remove the coupling and ramp assembly.

12A. On 883C and 1200C models, remove the bolt and washer securing the rod assembly to the shift lever, then remove the shift lever.

12B. On models except 883C and 1200C models, remove the clamp bolt and washer securing the shift lever to the shift shaft, then remove the shift lever.

13. Unscrew the clutch cable housing fitting (**Figure 16**) from the primary drive cover.

14. Remove the primary drive cover mounting bolts, then remove the cover and gasket.

15. Remove the dowel pins, if necessary.

16. If necessary, remove the clutch mechanism as described in this chapter.

17. If necessary, service the following components as described in this chapter:

- a. Clutch release mechanism.
- b. Primary chain adjuster.
- c. Shift shaft oil seal.

Installation

1. Clean the primary drive over and engine crankcase gasket surfaces and dry thoroughly.

2. Using a new gasket, install the primary chain cover onto the crankcase. Refer to **Figure 17** and install the cover mounting screws and tighten in a crisscross pattern to 80-110 in.-lb. (9-12 N•m).

3. Inspect the O-ring on the end of the cable housing fitting (**Figure 18**). Replace if damaged.

4. Install the cable housing fitting and tighten to 36-60 in.-lb. (4-7 N•m).

5A. On 1994-1996 models, install the coupling onto the cable end with the rounded side facing out and the ramp connector button facing in.

5B. On 1997-2003 models, install the coupling onto the cable end with the rounded side facing in and the ramp connector button facing out. With the retaining side of the ramp facing in; install the ramp hook around the coupling button.

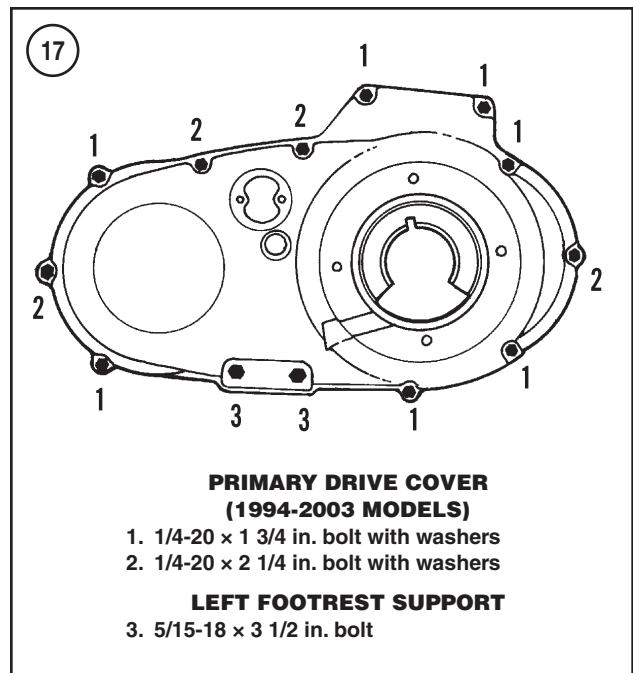

Then rotate the assembly counterclockwise until the tang on the inner ramp fits into the primary drive cover slot.

6. Thread the nut onto the clutch adjusting screw until the slot in the end of the screw is accessible with a screwdriver. Then align and install the hex portion on the nut into the

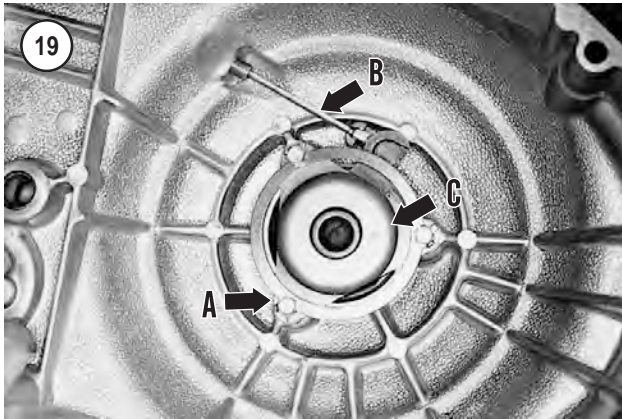

outer ramp recess. Turn the clutch adjusting screw counter-clockwise until resistance is felt, then back off 1/4 turn.

7. Adjust the clutch (Chapter Three). The spring and lockplate (B, **Figure 14**) will be installed during the clutch adjustment procedure.

8. Adjust the primary chain (Chapter Three).

9. Refill the transmission oil (Chapter Three).

10A. On 883C and 1200C models, install the shift lever and reconnect the rod assembly to the shift lever. Tighten the rod bolt to 15in.-lb. (11 N•m).

10B. On all models except 883C and 1200C models, install the shift lever and tighten the clamp bolt to 80-110 in.-lb. (9-12 N•m).

11. Install the left side footrest (Chapter Seventeen).
12. Reconnect the negative battery cable (Chapter Twelve).

CLUTCH RELEASE MECHANISM (1991-1993)

Refer to **Figure 1**.

Removal

1. Remove the primary drive cover as described in this chapter.
2. Pry the lockplate tabs (A, **Figure 19**) away from the mounting screws and remove the lockplate and screws.
3. Remove the clutch release mechanism from the cover and disconnect the cable (B, **Figure 19**) from the ramp and coupling. Remove the clutch mechanism.

Inspection

1. Wash the clutch release mechanism in solvent and dry thoroughly.
2. Inspect the balls and ramp sockets (**Figure 20**) for pitting, severe wear or other damage.
3. Inspect the adjusting screw (**Figure 21**) for thread or bearing damage.
4. Replace the lockplate if the tabs are weak or broken.
5. Replace severely worn or damaged parts as required.

Installation

1. Install the cable coupling onto the end of the clutch cable. Place the coupling in the ramp.
2. Apply grease to the ball and ramp surfaces (**Figure 20**) and insert the balls into the ramp sockets.
3. Assemble the inner and outer ramps (C, **Figure 19**) and install on the primary drive cover. Install the lockplate and the ramp mounting screws. Tighten screws securely. Bend the lockplate tabs over the screws to lock them in place.
4. Install the primary drive cover as described in this chapter.
5. Adjust the clutch (Chapter Three).

CLUTCH RELEASE MECHANISM (1994-2003 MODELS)

Refer to **Figure 12**.

Removal

1. Slide the rubber boot off the clutch in-line cable adjuster.
2. Loosen the adjuster jam nut (A, **Figure 13**) and turn the adjuster (B) to provide maximum cable slack.

3. Remove the clutch spring cover.
4. Remove the quad ring (A, **Figure 14**).
5. Remove the spring and lockplate (B, **Figure 14**).
6. Turn the clutch adjusting screw (A, **Figure 15**) clockwise and release the ramp (B) and coupling (C). Turn the clutch adjusting screw clockwise to move the ramp assembly forward. Then unscrew the nut (D, **Figure 15**) from the end of the adjusting screw and remove it.
7. Pivot the hook on the ramp to the rear of the cable end coupling. Disconnect and remove the clutch cable from the slot in the coupling. Remove the coupling and ramp assembly.
8. Remove the snap ring (**Figure 22**) securing the inner and outer ramp halves. Separate the halves and remove the ramps and balls.

Inspection

1. Wash the clutch release mechanism in solvent and dry thoroughly.
2. Check the balls and ramp sockets (**Figure 23**) for pitting, severe wear or other damage.
3. Check the adjusting screw (**Figure 24**) for thread or bearing damage.
4. Replace the lockplate if the tabs are weak or broken.
5. Replace severely worn or damaged parts as required.

Installation

Refer to **Figure 12**.

1. Apply grease to the ball and ramp surfaces (**Figure 23**) and insert the balls into the outer ramp sockets.
2. Install the inner ramp on the outer ramp hook so the punch mark (A, **Figure 25**) on the inner ramp aligns with the hook of the outer ramp (B).
- 3A. On 1994-1996 models, install the coupling onto the cable end with the rounded side facing out and the ramp connector button facing in.
- 3B. On 1997-2003 models, install the coupling onto the cable end with the rounded side facing in and the ramp connector button facing out. With the retaining side of the ramp facing in, install the ramp hook around the coupling button. Then rotate the assembly counterclockwise until the tang on the inner ramp fits into the primary drive cover slot.
4. Thread the nut onto the clutch adjusting screw until the slot in the end of the screw is accessible with a screwdriver. Then align and install the hex portion on the nut into the outer ramp recess (**Figure 26**). Turn the clutch adjusting screw counterclockwise until resistance is felt, then back off 1/4 turn.
5. Adjust the clutch as described in Chapter Three. The spring and lockplate shown in B, **Figure 14** will be installed during the clutch adjustment procedure.

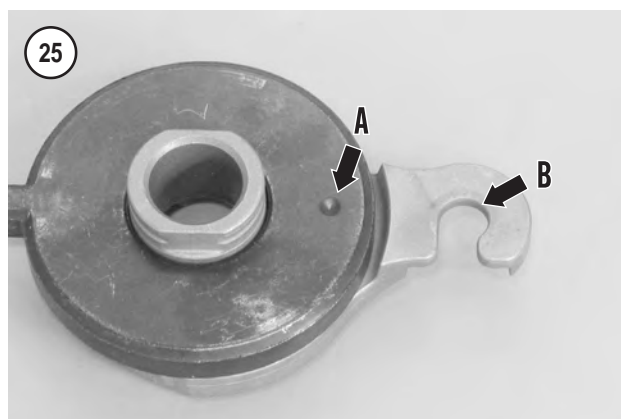

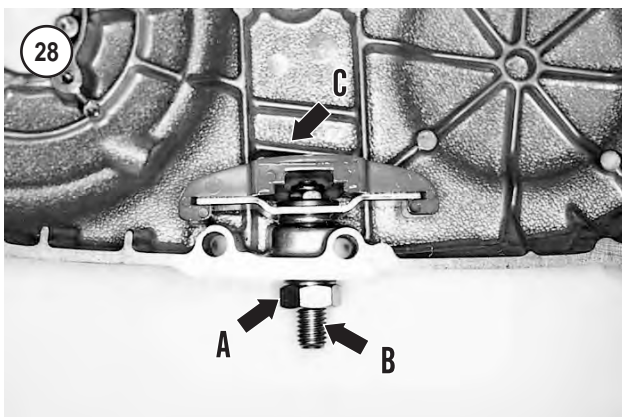
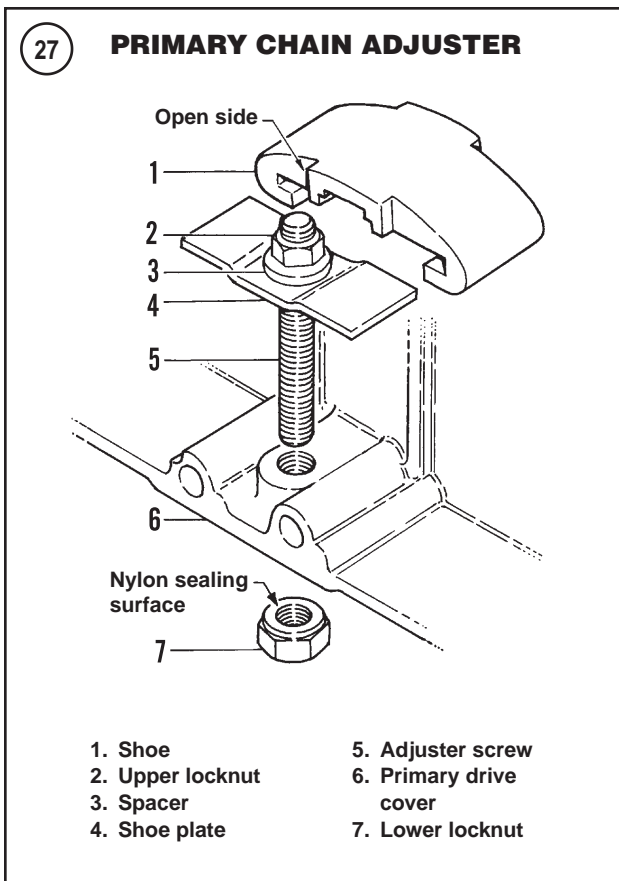
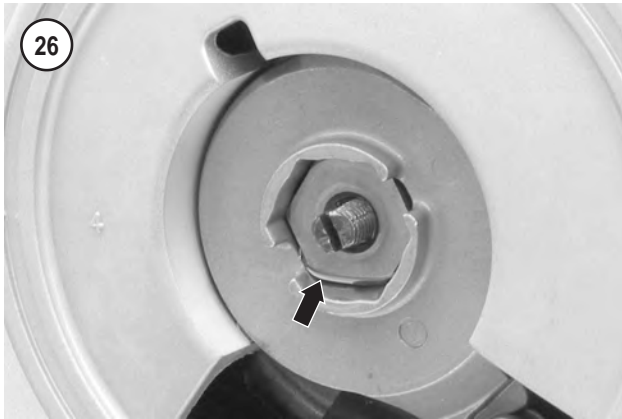

PRIMARY CHAIN ADJUSTER

Refer to **Figure 27**.

The primary chain adjuster assembly is mounted inside the primary drive cover.

Removal

1. Remove the primary drive cover as described in this chapter.
2. Remove the adjuster screw locknut (A, **Figure 28**).
3. Turn the adjuster screw (B, **Figure 28**) to remove it from the threaded boss in the primary drive cover.
4. Slide the adjuster shoe (C, **Figure 28**) off the shoe plate.
5. Remove the upper locknut and shoe plate.

Inspection

1. Clean all parts in solvent and dry thoroughly.
2. Replace the adjuster shoe (C, **Figure 28**) if severely worn or damaged.
3. Replace the shoe plate if bent or otherwise damaged.
4. Replace the locknut(s) and adjuster screw if thread damage is apparent.

Installation

1. Install the shoe plate over the top of the adjuster screw.
2. Place the spacer over the top of the adjuster screw and rest it on top of the shoe plate.
3. Thread the upper primary chain adjuster locknut onto the top of the adjuster screw. Tighten the upper locknut to 120-144 in.-lb. (14-16 N•m).
4. Slide the open side of the adjuster shoe over the shoe plate until the upper locknut is positioned against the closed side of the shoe.
5. Place the adjuster assembly into the primary drive cover so that the closed side of the adjuster shoe (C, **Figure 28**) faces toward the primary drive cover.
6. Thread the adjuster screw (B, **Figure 28**) into the boss at the bottom of the primary drive cover.
7. Thread the lower locknut (A, **Figure 28**) onto the adjuster screw.
8. Install the primary drive cover as described in this chapter.
9. Adjust the primary chain (Chapter Three).

PRIMARY DRIVE/CLUTCH

Refer to **Figure 29**.

Tools

Complete disassembly of the clutch requires the use of a clutch spring compression tool (**Figure 30** [part No. HD-38515A, 38515-90/91 or equivalent]). If the compress-

29

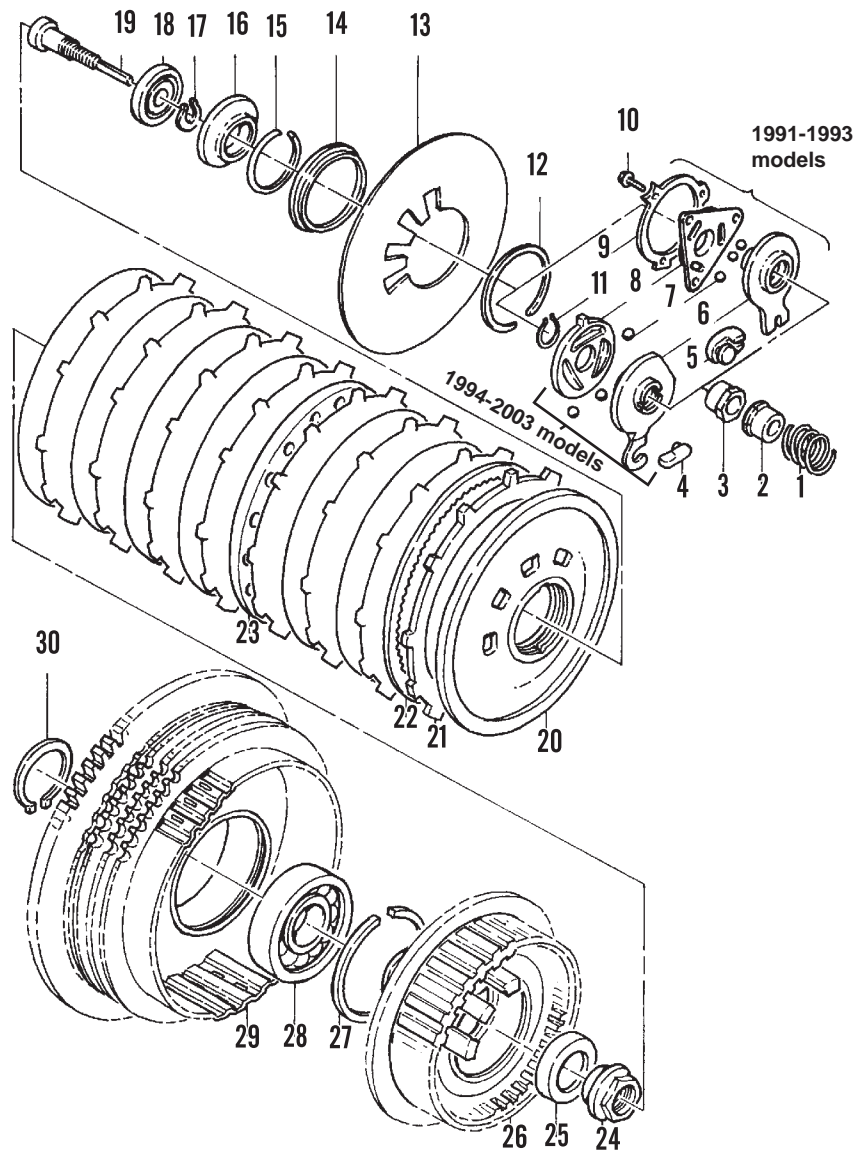
CLUTCH

- | | |
|----------------------|----------------------------|
| 1. Spring | 16. Release plate |
| 2. Locking plate | 17. Retaining ring |
| 3. Nut | 18. Bearing |
| 4. Coupling | 19. Adjusting screw |
| 5. Coupling | 20. Pressure plate |
| 6. Outer ramp | 21. Friction plate |
| 7. Balls (3) | 22. Steel plates |
| 8. Inner ramp | 23. Spring plate |
| 9. Lockplate | 24. Nut |
| 10. Bolt | 25. Washer |
| 11. Snap ring | 26. Clutch hub |
| 12. Snap ring | 27. Retaining ring |
| 13. Diaphragm spring | 28. Bearing |
| 14. Spring seat | 29. Clutch shell/ring gear |
| 15. Retaining ring | 30. Retaining ring |

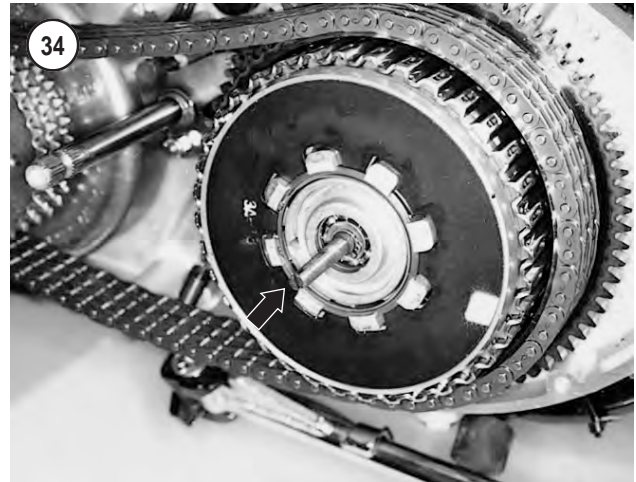
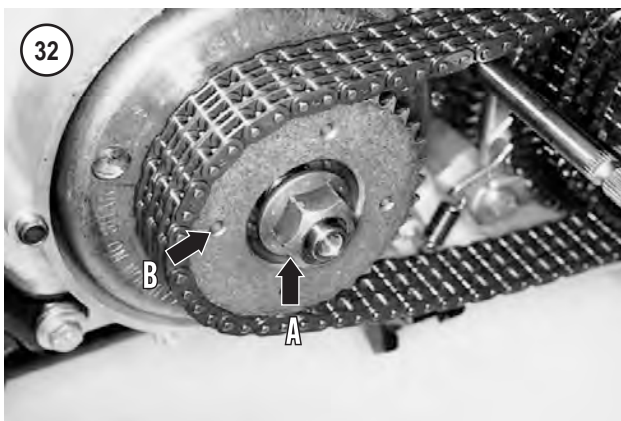
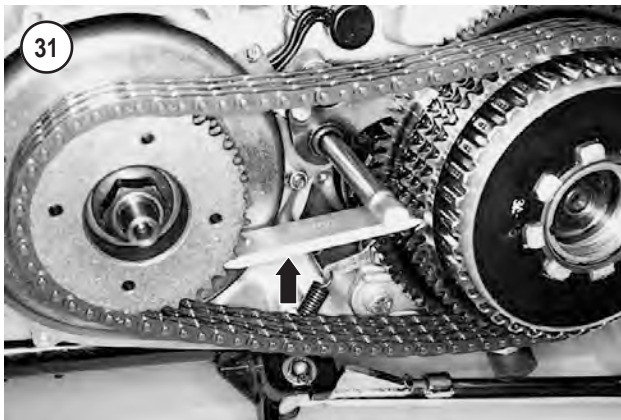

tion tool is not available, remove the clutch intact from the motorcycle and take it to a dealership for disassembly or service. Do *not* attempt to disassemble the clutch without the tool.

Clutch/Primary Chain/Engine Sprocket Removal (Clutch is Not Disassembled)

This procedure describes removal of the clutch, primary chain and engine sprocket, which allows later clutch disassembly as described in *Clutch Hub and Shell Disassembly/Reassembly* in this section. If clutch disassembly with the clutch mounted on the motorcycle is desired, refer to *Clutch Disassembly on Motorcycle* in this section.

1. Shift the transmission into 5th gear.
2. Disconnect the negative battery cable (Chapter Twelve).
3. Remove the primary drive cover as described in this chapter.
4. Install the sprocket locking link (part No. HD-38362 or equivalent) between the engine sprocket and clutch shell as shown in **Figure 31**.
5. Remove the engine sprocket nut (**A**, **Figure 32**).
6. Loosen the engine sprocket by pulling it (do not remove it). If the engine sprocket is tight, break it loose with a puller and two bolts installed on the sprocket face (**B**, **Figure 32**).
7. Remove the snap ring (**Figure 33**) holding the release plate/adjusting screw in position.
8. Remove the release plate/adjusting screw assembly (**Figure 34**).
9. The clutch nut (**Figure 35**) has left-hand threads. Turn the clutch nut clockwise to loosen it. Then remove the clutch nut and washer (**Figure 36**).
10. Remove the locking link (**Figure 31**).
11. Remove the engine sprocket, primary chain and clutch as an assembly (**Figure 37**).



Clutch Disassembly on Motorcycle

This procedure describes disassembly of the clutch while it is mounted on the motorcycle. Engine sprocket and primary chain removal is not required. Read this procedure completely before starting disassembly.

1. Disconnect the negative battery cable (Chapter Twelve).
2. Remove the primary drive cover as described in this chapter.

WARNING

Do not attempt to disassemble the clutch without using a clutch spring compression tool. (Figure 30 [part No. HD-38515A, part No. 38515-90/91 or equivalent]). The diaphragm spring snap ring (12, Figure 29) is held under considerable pressure and will fly out if pressure is not first removed.

3. To remove the diaphragm spring snap ring, perform the following:
 - a. Thread the clutch spring compression tool forcing screw onto the clutch adjusting screw as shown in Figure 38.
 - b. Position the spring compression tool (Figure 39) against the diaphragm spring and thread the tool handle onto the end of the forcing screw.

CAUTION

Turn the clutch compression tool handle only the amount required to compress the diaphragm spring and remove the snap ring. Excessive compression of the diaphragm spring may damage the clutch pressure plate.

- c. Hold the compression tool forcing screw with a wrench (Figure 40) and turn the tool handle clockwise to compress the diaphragm spring.
- d. Remove the snap ring (Figure 41) and spring seat (Figure 42) from the groove in the clutch hub.
- e. Remove the diaphragm spring, pressure plate, clutch adjusting screw and spring compressing tool as an assembly; see Figure 43.

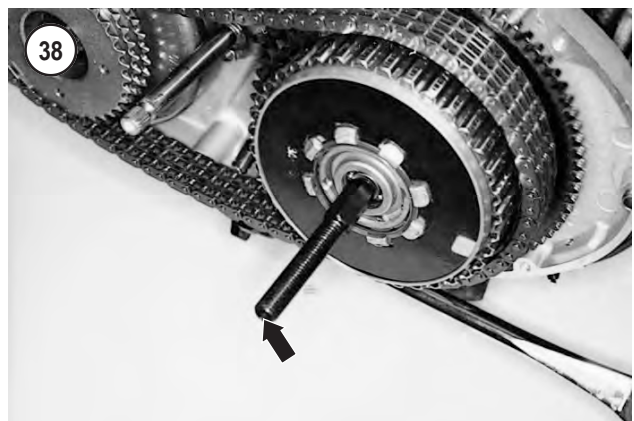
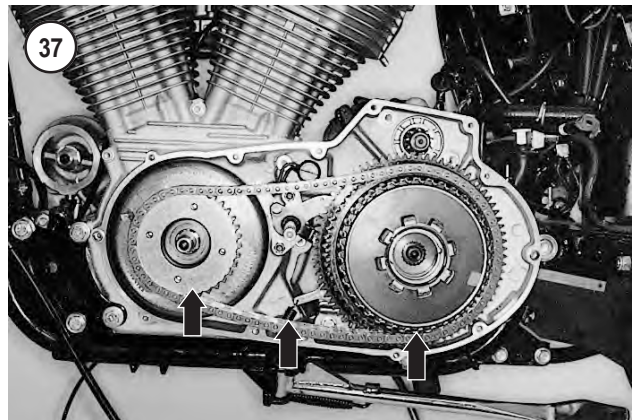

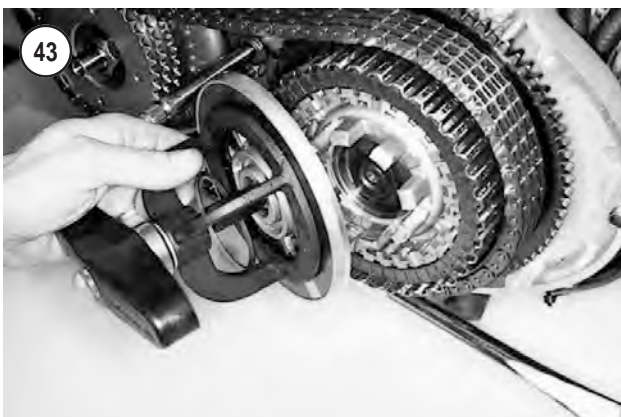

NOTE

Do not loosen the spring compressing tool to remove the diaphragm spring or pressure plate unless these parts require close inspection or replacement. Loosening and removing the clutch compression tool requires repositioning of the diaphragm spring during reassembly. This step will not be required as long as the compression tool is not removed from these parts.

4. Remove the friction and steel clutch plates (**Figure 44**) and the spring plate, from the clutch assembly in the order shown in **Figure 29**. Note the spring plate installed between the fourth and fifth friction plates (**Figure 45**).

NOTE

Further removal steps are not required unless it is necessary to separate the clutch hub and shell assembly. Remove these parts as described in **Clutch Hub and Shell Disassembly/Reassembly** in this section.

Clutch Inspection

1. Clean all parts, except friction plates and bearings, in a non-oil based solvent and thoroughly dry with compressed air. Place all cleaned parts on lint free paper towels.
2. Check each steel plate (A, **Figure 46**) for visual damage such as cracks or wear grooves. Then place each plate on a surface plate, such as piece of glass, and check for warp

with a feeler gauge. Replace the steel plates as a set if any one plate is warped more than 0.006 in. (0.15 mm).

3. Inspect the friction plates (B, **Figure 46**) for worn or grooved lining surfaces. Replace the friction plates as a set if any one plate is damaged. If the friction plates do not show visual wear or damage, wipe each plate thoroughly with a lint-free cloth to remove as much oil from the plates as possible. Measure each plate individually and compare to the measurements in **Table 1**. Stack each of the eight friction plates on top of each other and measure the thickness of the assembly. Replace the friction plates as an assembly if the combined thickness of the eight plates is less than 0.661 in. (16.79 mm).

4. Measure each steel plate and compare the thickness to the specification in **Table 1**. Replace if not within specification.

5. Check the spring plate (C, **Figure 46**) for cracks or damage. Check for loose or damaged rivets. Replace the spring plate if necessary.

6. Check the clutch diaphragm spring for cracks or damage. Check also for bent or damaged tabs. Replace the diaphragm spring if necessary.

7. A ball bearing is pressed into the clutch shell and the clutch hub is pressed into the bearing. Hold the clutch hub and rotate the clutch shell by hand. The shell should turn with no sign of roughness or tightness. If the clutch shell binds or turns roughly, the bearing is damaged and must be replaced. Refer to Step 10.

8. The steel clutch plate inner teeth mesh with the clutch hub splines. Check the splines for cracks or galling. They must be smooth for chatter-free clutch operation. If the clutch hub splines are damaged, the clutch hub must be replaced; refer to Step 10.

9. The friction plates (B, **Figure 46**) have tabs that slide in the clutch shell grooves. Inspect the shell grooves for cracks or wear grooves. The grooves must be smooth for chatter-free clutch operation. If the clutch shell grooves are damaged or worn severely, replace the clutch shell; refer to Step 10.

10. Check the primary chain sprocket and the starter ring gear on the clutch shell for cracks, deep scoring, excessive wear or heat discoloration. If either the sprocket or ring gear is severely worn or damaged, replace the clutch shell; refer to Step 11. If the sprocket is worn, also check the primary chain and the engine sprocket as described in this chapter.

11. If the clutch hub, shell or bearing require replacement, refer to *Clutch Hub and Shell Disassembly/Reassembly* in this section.

Primary Chain

Replace the primary chain if severely worn or damaged. Do not attempt to repair the chain. If the primary chain is worn or damaged, check the engine sprocket and clutch shell sprocket for wear or damage. Replace parts as required.

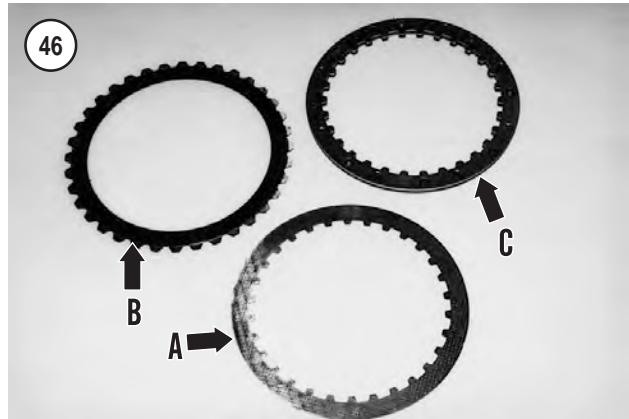

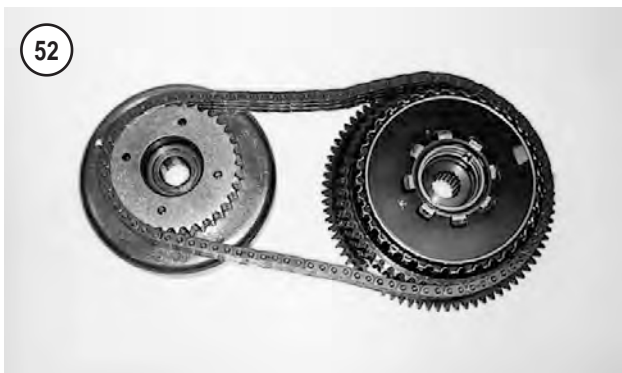
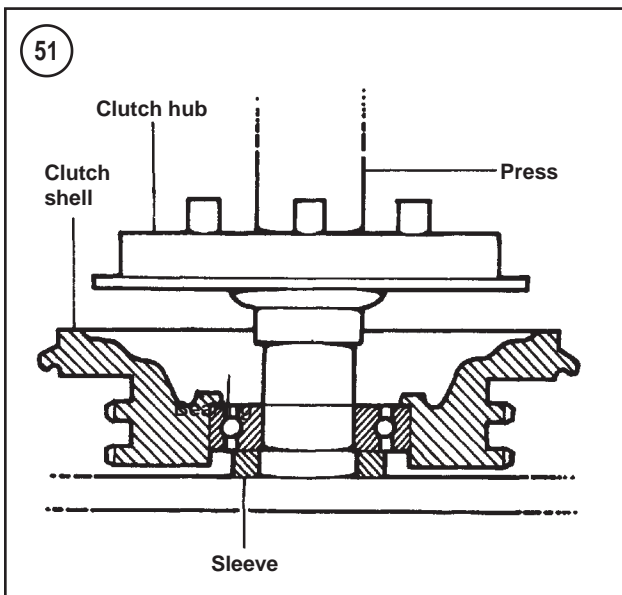

Clutch Hub and Shell Disassembly/Reassembly

The clutch hub and shell should not be separated unless replacement of the hub, shell or bearing is required. Disassembly of the hub and shell will damage the ball bearing; bearing replacement will be required during reassembly.

A press is required for this procedure.

1. Remove the clutch plates from the clutch hub and shell assembly, if they have not been previously removed. Refer to *Clutch Disassembly on Motorcycle* in this section.

2. Remove the snap ring from the clutch hub groove (**Figure 47**).
3. Support the clutch hub and shell in a press (**Figure 48**) and press the clutch hub out of the bearing. See **Figure 49**. Remove the clutch shell from the press.
4. Locate the snap ring (**Figure 50**) securing the bearing in the clutch shell and remove it.
5. The bearing must be removed through the front side of the shell. The clutch shell is manufactured with a shoulder on the rear (primary chain) side. Support the clutch shell in the press and press the bearing out of the shell. Discard the bearing.
6. Discard worn or damaged parts. Clean reusable and new parts, except bearings and snap rings, in non-oil based solvent and dry thoroughly.
7. Place the clutch shell into the press. Align the bearing with the clutch shell and press the bearing into the shell until the bearing bottoms out against lower shoulder. When pressing the bearing into the clutch shell, press only on the outer bearing race. Refer to *Service Procedures* in Chapter One for additional information.
8. Install a new bearing snap ring into the clutch shell groove (**Figure 50**). Make sure the snap ring seats in the groove completely.
9. Press the clutch hub into the clutch shell as follows:

CAUTION

*Failure to support the inner bearing race properly will cause bearing and clutch shell damage. Refer to **Figure 51** to make sure the inner bearing race is supported properly.*

- a. Place the clutch shell in a press. Support the inner bearing race with a sleeve as shown in **Figure 51**.
 - b. Align the clutch hub with the bearing and press the clutch hub into the bearing until the clutch hub shoulder seats against the bearing.
 - c. Install a new clutch hub snap ring (**Figure 47**). Make sure the snap ring seats in the clutch hub groove completely.
10. After completing assembly, hold the clutch hub and rotate the clutch shell by hand. The shell should turn smoothly with no roughness or binding. If the clutch shell binds or turns roughly, the bearing may have been damaged during reassembly. Correct before installing.

Clutch Assembly

After assembly, the clutch will be installed back onto the motorcycle. If the clutch assembly was not disassembled, refer to *Clutch Installation* in this section.

Refer to **Figure 29**.

NOTE

Before installing the clutch plates, count the number of each plate. The set should include eight friction plates, six steel plates and one spring plate.

1. Soak all of the clutch plates in clean transmission oil for approximately 5 minutes before installing them.
2. Align the tabs on a friction plate with the clutch shell grooves and install the plate. Then align the inner teeth on a steel plate with the clutch hub grooves and install the plate. Repeat until all of the clutch plates have been installed. Install the spring plate (**Figure 45**) between the fourth and fifth friction plates. The last plate installed must be a friction plate.

NOTE

During clutch removal, if the spring compressing tool was not removed from the diaphragm spring and pressure plate, proceed to Step 4. If the spring compressing tool was removed and the clutch diaphragm spring was separated from the pressure plate, continue with Step 3.

3. Assemble the pressure plate and clutch diaphragm spring as follows:

- a. Install the adjusting screw assembly (release plate, snap ring, bearing and adjusting screw) into the pressure plate. Install the release plate by aligning its tabs with the slots in the pressure plate. Secure the release plate by installing the retaining ring into the pressure plate groove. Make sure the retaining ring seats in the groove completely.
- b. The diaphragm spring is concave. Install the diaphragm spring onto the pressure plate so the concave side faces the pressure plate—the convex side must face out.
- c. Install the spring seat with its flat, larger outer diameter side facing toward the diaphragm spring.

WARNING

Because of the force required to compress the diaphragm spring when installing the snap ring, a clutch spring compression (part No.HD-38515A, 38515-90/91 or equivalent) must be used. Severe personal injury from the diaphragm spring flying out could occur if the special tool is not used.

4. To install the diaphragm spring snap ring, use a clutch spring compression tool to perform the following:

- a. Thread the spring compression tool forcing screw onto the clutch adjusting screw.
- b. Position the spring compression tool against the diaphragm spring and thread the tool handle onto the end of the forcing screw. Do not apply pressure against the diaphragm spring at this time.
- c. Align the square holes in the pressure plate and diaphragm spring with the prongs on the face of the clutch hub. Then place the spring seat, snap ring, diaphragm spring, pressure plate, adjusting screw assembly and compressing tool onto the clutch hub (**Figure 43**).

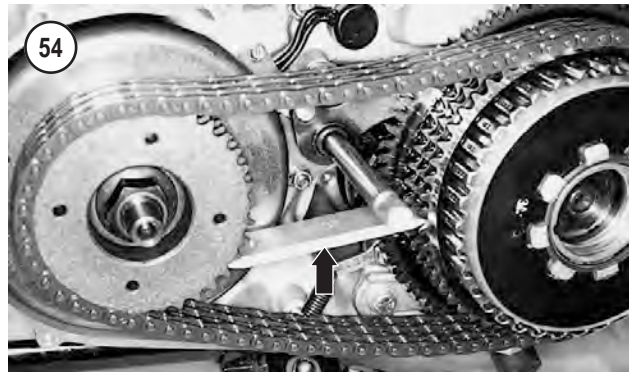
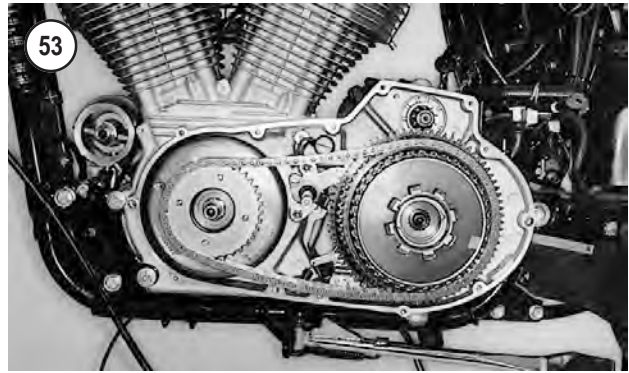

CAUTION

Turn the compression tool handle only the amount required to compress the diaphragm spring and install the snap ring. Excessive compression of the diaphragm spring may damage the clutch pressure plate.

- d. Hold the compression tool forcing screw with a wrench and turn the tool handle clockwise to compress the diaphragm spring.
- e. Install the spring seat and snap ring into the groove in the clutch hub.
- f. After making sure the snap ring is seated completely in the clutch hub groove, turn the compressing tool handle counterclockwise while checking that the clutch spring seat lip seats inside the snap ring. After all tension has been removed from the compressing tool, remove it from the release plate.



5. Remove the release plate retaining ring. Then remove the adjusting screw assembly (release plate, retaining ring, bearing and adjusting screw).

Clutch Installation

CAUTION

The rotor is mounted on the engine sprocket. Carefully inspect the inside of the rotor for small bolts, washers or other metal debris that may have been picked up by the magnets. This debris can cause severe damage to the alternator stator assembly.



1. Assemble the clutch assembly as described in this section.
2. The engine sprocket, primary chain and clutch are installed as an assembly. Assemble the engine sprocket, clutch and primary chain as shown in **Figure 52**.
3. Lift the primary drive assembly as a unit and slide the engine sprocket and clutch into the primary chaincase. See **Figure 53**.
4. Install a sprocket locking link (**Figure 54**) (part No. HD-38362 or equivalent) between the engine sprocket and clutch shell.

CAUTION

The engine sprocket is tightened to a high torque specification. Be sure to hold the sprocket securely when tightening the nut.



5. Apply 2-3 drops of Loctite 262 (red) to the engine sprocket nut threads and install the nut (**Figure 55**) onto the sprocket shaft. Tighten the engine sprocket nut to the torque specified in **Table 2**.
6. Install the clutch nut Belleville washer onto the mainshaft so that the word OUT on the washer faces away from the engine (**Figure 56**).
7. Apply threadlock (Loctite 262 or equivalent) to the clutch nut threads and install the nut onto the mainshaft by turning the nut counterclockwise. Tighten the clutch nut (**Figure 57**) to 70-80 ft.-lb. (96-108 N•m).
8. Remove the sprocket locking link (**Figure 54**).
9. Install the adjusting screw assembly (**Figure 58**) by aligning the two tabs on the release plate perimeter with the two recesses in the pressure plate.
10. Install a new retaining ring (**Figure 59**).
11. Install the primary drive cover as described in this chapter.
12. Adjust the primary chain (Chapter Three).
13. Refill the primary chain housing (Chapter Three).
14. Reconnect the negative battery cable (Chapter Twelve).



CLUTCH CABLE

Replacement

1991-1993 models

Refer to **Figure 60**.

60

**CLUTCH RELEASE MECHANISM
(1991-1993 MODELS)**

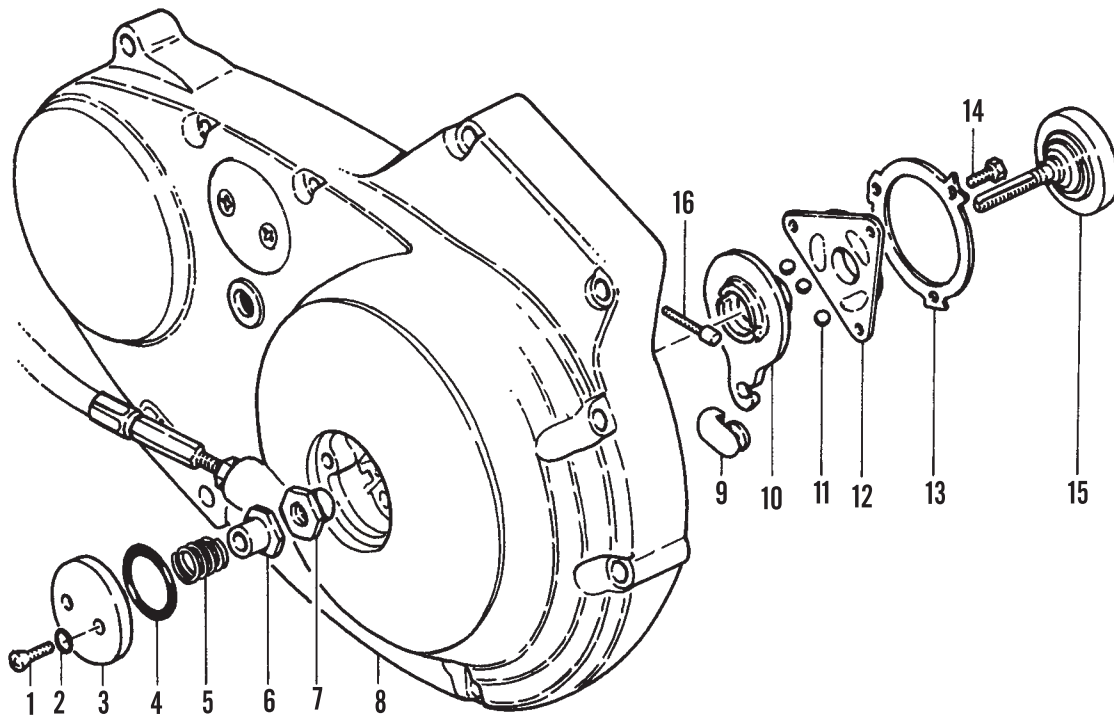

- | | |
|------------------------|-------------------------------------|
| 1. Screw | 9. Cable coupling |
| 2. O-ring | 10. Outer ramp |
| 3. Clutch spring cover | 11. Ball (3) |
| 4. O-ring | 12. Inner ramp |
| 5. Spring | 13. Lockplate |
| 6. Lockplate | 14. Bolt |
| 7. Nut | 15. Clutch adjusting screw assembly |
| 8. Primary drive cover | 16. Clutch cable |

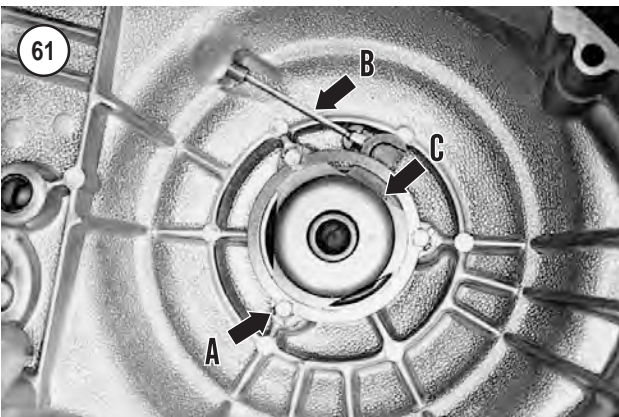

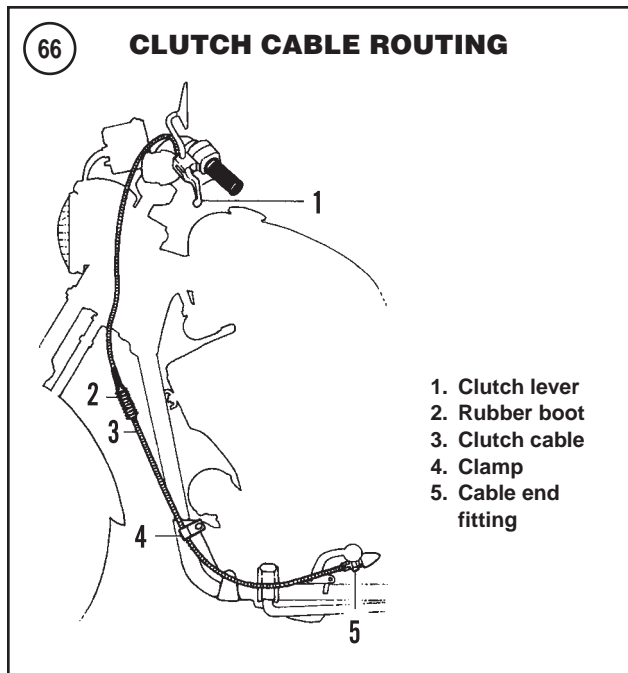
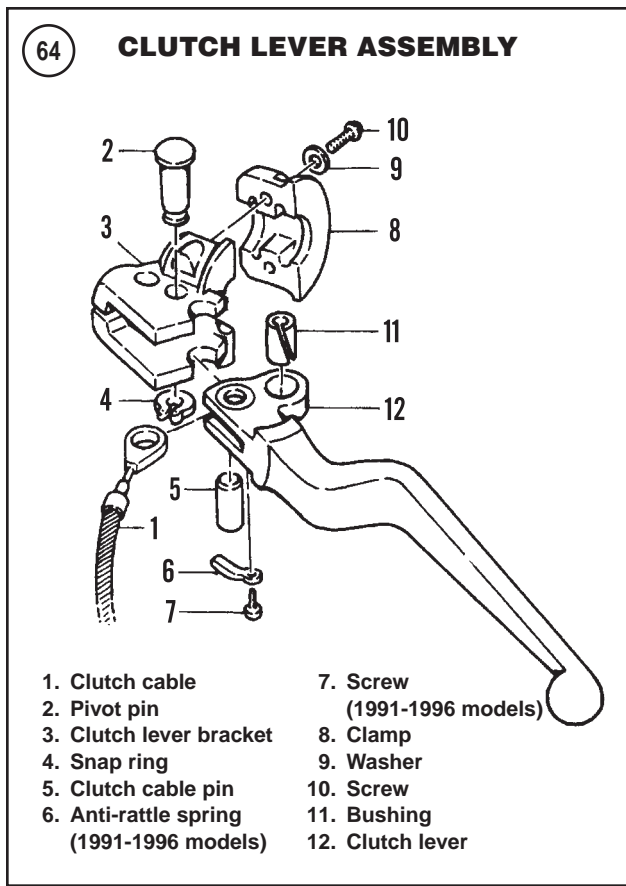

1. Remove the primary drive cover as described in this chapter.
2. Pry the lockplate tabs (A, **Figure 61**) away from the mounting screws and remove the lockplate and screws.
3. Remove the clutch release mechanism from the cover and disconnect the cable (B, **Figure 61**) from the ramp and coupling. Remove the release clutch mechanism (C, **Figure 61**).
4. Turn the clutch cable (**Figure 62**) counterclockwise and remove it from the primary drive cover.
5. Remove the O-ring (**Figure 63**) from the lower cable end fitting.
6. At the clutch lever, remove the pivot pin circlip and remove the pivot pin (2, **Figure 64**).
7. Slide the clutch lever out of the bracket (3, **Figure 64**).
8. Remove the clutch cable and disconnect the clutch cable from the lever (12, **Figure 64**).
9. Remove the screw and anti-rattle spring from the bottom of the clutch lever (6, **Figure 64**).
10. Note the cable routing before removing it. The new cable must be routed along the same path. Slide the clutch cable through the guide clip (**Figure 65**) and remove the clutch cable.
11. Slide the O-ring over the lower cable end fitting (**Figure 63**) and insert the cable into the primary drive cover. Turn the cable (**Figure 62**) clockwise and tighten it securely.
12. Connect the lower end of the clutch cable to the cable coupling. Connect the cable coupling to the outer ramp (**Figure 60**).
13. Install the clutch release mechanism and lockplate onto the primary drive cover with the mounting screws. Tighten the screws securely. Bend the lockplate tabs over the screw heads to lock them.
14. Install the primary drive cover as described in this chapter.
15. Route the clutch cable as shown in **Figure 66**.

67

CLUTCH RELEASE MECHANISM (1994-2003 MODELS)

1. Screw and washer
2. Clutch spring cover
3. Spring
4. Lockplate
5. Nut
6. Coupling (1994-1996 models)
7. Outer ramp
8. Ball (3)
9. Coupling (1997-2003 models)
10. Inner ramp
11. Quad ring
12. Snap ring
13. Primary drive cover
14. Clutch adjusting screw assembly
15. Clutch cable
16. O-ring

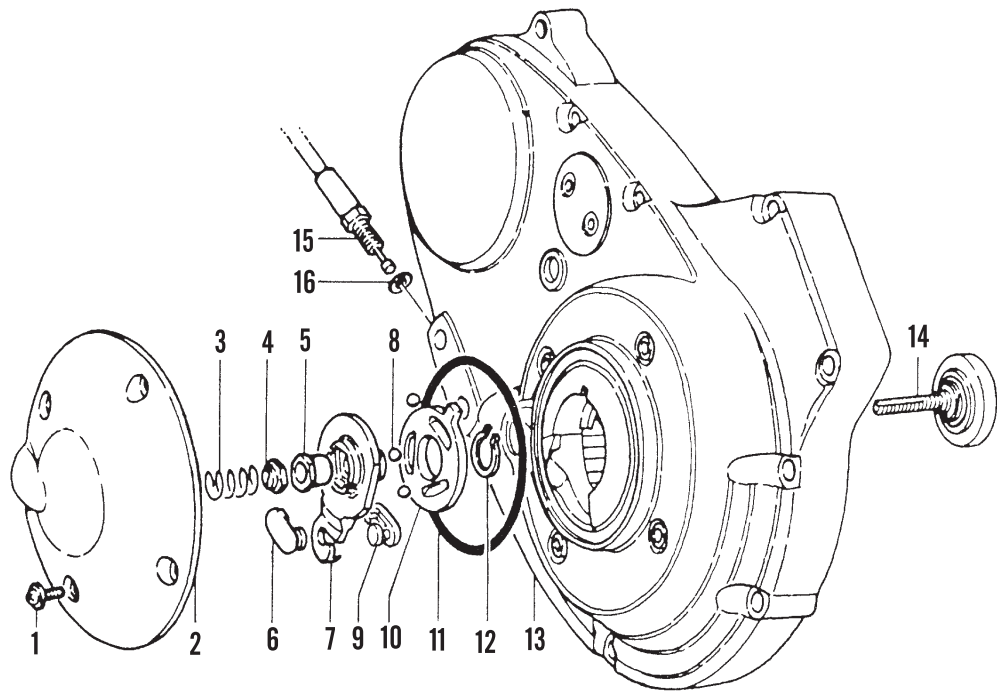

16. Install the anti-rattle spring and screw onto the clutch lever (12, **Figure 64**).
17. Connect the clutch cable to the clutch lever and secure it with the clutch cable pin (5, **Figure 64**).
18. Install the clutch lever into the bracket (3, **Figure 64**).
19. Wipe the pivot pin shoulder with a small amount of anti-seize compound. Install the pivot pin through the clutch bracket and lever and secure it with the snap ring (4, **Figure 64**).
20. Adjust the clutch (Chapter Three).

1994-2003 modelsRefer to **Figure 67**.**CAUTION**

*When removing the clutch spring cover (2, **Figure 67**), do not remove or damage the quad ring (11) in the primary drive cover.*

1. Remove the clutch spring cover.
2. Remove the spring and lockplate.
3. Turn the clutch adjusting screw clockwise and release the ramp and coupling mechanism.

4. Turn the clutch adjusting screw clockwise to move the ramp assembly forward. Then unscrew the nut from the end of the adjusting screw and remove it.
5. Pivot the hook on the ramp to the rear of the cable end coupling. Then disconnect and remove the clutch cable from the coupling slot.
6. Turn the clutch cable (**Figure 62**) counterclockwise and remove it from the primary drive cover.
7. Remove the O-ring (**Figure 63**) from the lower cable end fitting.
8. At the clutch lever, remove the pivot pin snap ring (4, **Figure 64**) and remove the pivot pin (2).
9. Slide the clutch lever out of its bracket (3, **Figure 64**).
10. Remove the clutch cable and disconnect the clutch cable from the lever (12, **Figure 64**).
11. On 1994-1996 models, remove the screw (7, **Figure 64**) and anti-rattle spring (5) from the bottom of the clutch lever.
12. Note the cable routing before removing it. The new cable must be routed along the same path. Slide the clutch cable through the guide clip (**Figure 65**) and remove the clutch cable.
13. Slide the O-ring over the lower cable end fitting (**Figure 63**) and insert the cable into the primary drive cover. Turn the cable (**Figure 62**) clockwise and tighten it securely.

14A. On 1994-1996 models, fit the coupling over the clutch cable with the rounded side facing out and the ramp connector button facing in.

14B. On 1997-2003 models, fit the coupling over the clutch cable with the rounded side facing in and the ramp connector button facing out. With the retaining side of the ramp facing in, install the ramp hook around the coupling button. Then rotate the assembly counterclockwise until the tang on the inner ramp fits into the primary drive cover slot.

15. Thread the nut onto the clutch adjusting screw until the slot in the end of the screw is accessible with a screwdriver. Then align and install the hex portion on the nut into the outer ramp recess. Turn the clutch adjusting screw counterclockwise until resistance is felt, then backoff 1/4 turn.

16. Adjust the clutch as described in Chapter Three. The spring and lockplate shown in **Figure 67** will be installed during the clutch adjustment procedure.

17. Route the clutch cable as shown in **Figure 66**.

18. Install the anti-rattle spring (6, **Figure 64**) and screw (7) onto the clutch lever (12).

19. Connect the clutch cable to the clutch lever and secure it with the clutch cable pin (5, **Figure 64**).

20. Install the clutch lever into the bracket.

21. Apply a small amount of anti-seize compound to the pivot pin shoulder. Then install the pivot pin through the clutch bracket and lever and secure it with the snap ring (4, **Figure 64**).

22. Adjust the clutch (Chapter Three).

Table 1 CLUTCH SPECIFICATIONS

| | New in. (mm) | Service limit in. (mm) |
|---|--------------------------------|-----------------------------------|
| Friction plates | | |
| Thickness | | |
| Individual plates | 0.0835-0.0897 (2.121-2.278) | — |
| Friction plate pack* | — | 0.6610 (16.79) |
| Steel plate thickness | 0.0609-0.0649 (1.547-1.648) | — |
| Warp (all plates) | — | 0.006 (0.15) |
| *Refer to text for measurement procedure. | | |

Table 2 CLUTCH TORQUE SPECIFICATIONS

| | ft.-lb. | in.-lb. | N.m |
|--|----------------|----------------|------------|
| Chain tensioner stud nut | 20-25 | — | 27-34 |
| Clutch cable housing fitting | — | 36-60 | 4-7 |
| Clutch lever clamp bolts | — | 60-80 | 7-9 |
| Clutch nut* | 70-80 | — | 95-108 |
| Clutch release mechanism screws | 22-40 | — | 2.5-4.5 |
| Engine sprocket nut* | | | |
| 1991-1997 models | 150-165 | — | 203-224 |
| 1998-2003 models | 190-210 | — | 258-285 |
| Inspection cover screws | — | 40-60 | 5-7 |
| Primary chain adjuster locknuts | | | |
| Upper | — | 120-144 | 14-16 |
| Lower | 20-25 | — | 27-34 |
| Primary drive cover mounting screws | — | 80-110 | 9-12 |
| Shift lever pinch bolt | — | 80-110 | 9-12 |
| Shift rod bolt | 15 | — | 11 |
| Transmission drain plug | 14-21 | — | 19-28 |
| *Apply threadlock (Loctite 262 or equivalent). | | | |

CHAPTER EIGHT

FOUR-SPEED TRANSMISSION (1986-1990 MODELS)

This chapter covers the four-speed transmission, internal gearshift assemblies and shift mechanism. **Tables 1-8** are at the end of this chapter.

When the clutch is engaged, the mainshaft is driven by the clutch hub, which is driven by the primary chain sprocket/clutch outer housing. Power flows from the mainshaft through the selected gear combination to the countershaft, which drives the main drive gear and transmission sprocket.

To gain access to the transmission and internal shift mechanism, it is not necessary to remove the engine or disassemble the crankcase. The transmission components are contained behind an access door on the left crankcase half.

TRANSMISSION

Transmission Removal

1. Drain the transmission/primary drive oil (Chapter Three).
2. Remove the clutch and primary chain (Chapter Six).
3. Remove the drive sprocket (Chapter Thirteen).
4. Remove the stator (Chapter Twelve).
5. Remove the thrust washer (**Figure 1**).
6. Remove the transmission access cover bolts. See **Figure 2**.
7. Remove the access cover (**Figure 2**) with the transmission and shift mechanism assembly attached. See **Figure 3**.

8. Remove the shift lever (**Figure 4**).

Transmission Installation

1. Install the shift shaft into the crankcase so that the shift lever arm is centered as shown in **Figure 5**.

NOTE

*Mark the shift shaft at the 12 o'clock position as shown in **Figure 6**. Marking the shaft provides a reference mark to determine if the shift lever arm position changes when installing the transmission.*

2. Install the transmission access cover (**Figure 3**). Then rotate the countershaft to check the shift shaft is engaged with the shifter pawl. To do so, lightly rotate the shift shaft. A noticeable resistance to movement indicates proper engagement.
3. Install the access cover bolts (**Figure 2**). The short bolt must be installed in the upper right hole. Tighten all access cover bolts to 14-19 ft.-lb. (19-26 N•m).

CAUTION

Do not use the old stator Torx screws. New Torx screws have a pellet formed locking compound on their threads. When new Torx screws are installed, the pellet breaks and

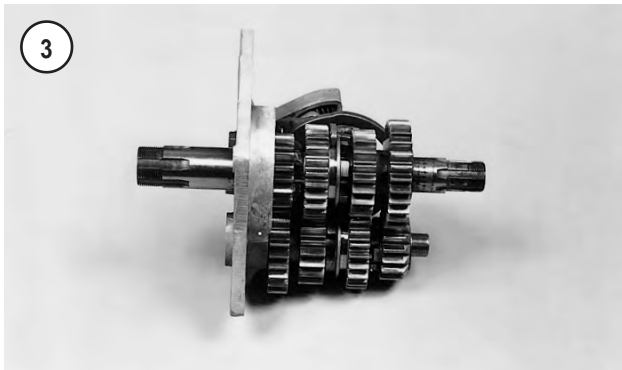
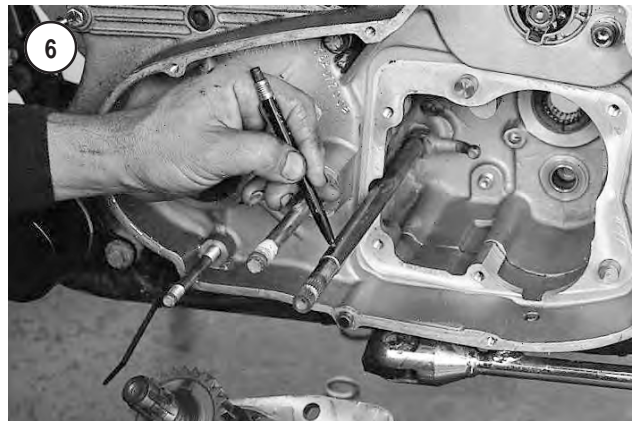
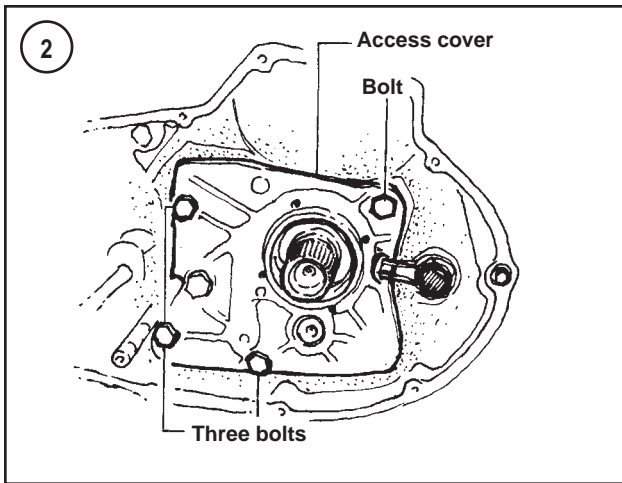
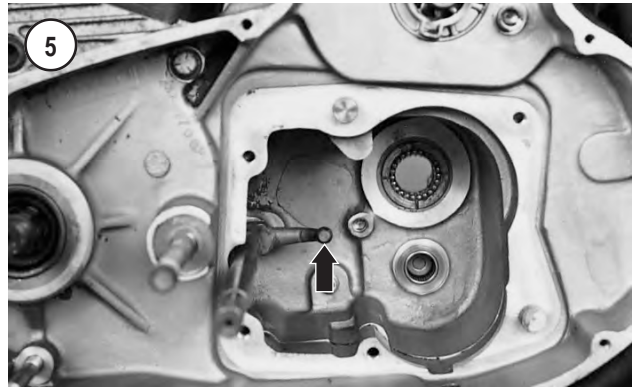

releases the locking compound on the bolt threads. The locking compound on the old bolts cannot be reused; if installed, the old bolts may loosen during engine operation.

4. Install the alternator stator as described in Chapter Twelve.
5. Install the clutch (Chapter Six).
6. Install the drive sprocket (Chapter Thirteen).
7. Install the rear chain. Adjust it as described in Chapter Three.
8. Refill the transmission/primary oil (Chapter Three).

Transmission Disassembly

Refer to **Figure 7**.

1. Pull the mainshaft assembly (**Figure 8**) from the clutch gear.
2. Remove the following from the countershaft:
 - a. First gear washer (**Figure 9**).
 - b. First gear (**Figure 10**).
 - c. Third gear washer (**Figure 11**).
3. Remove the shift fork shaft (**Figure 12**).
4. Remove the shift fork (**Figure 13**) from the countershaft third gear.
5. Remove the finger rollers (**Figure 14**) from the shift fork.
6. Remove countershaft third gear (**Figure 15**).
7. Remove mainshaft second gear (**Figure 16**).

7

TRANSMISSION

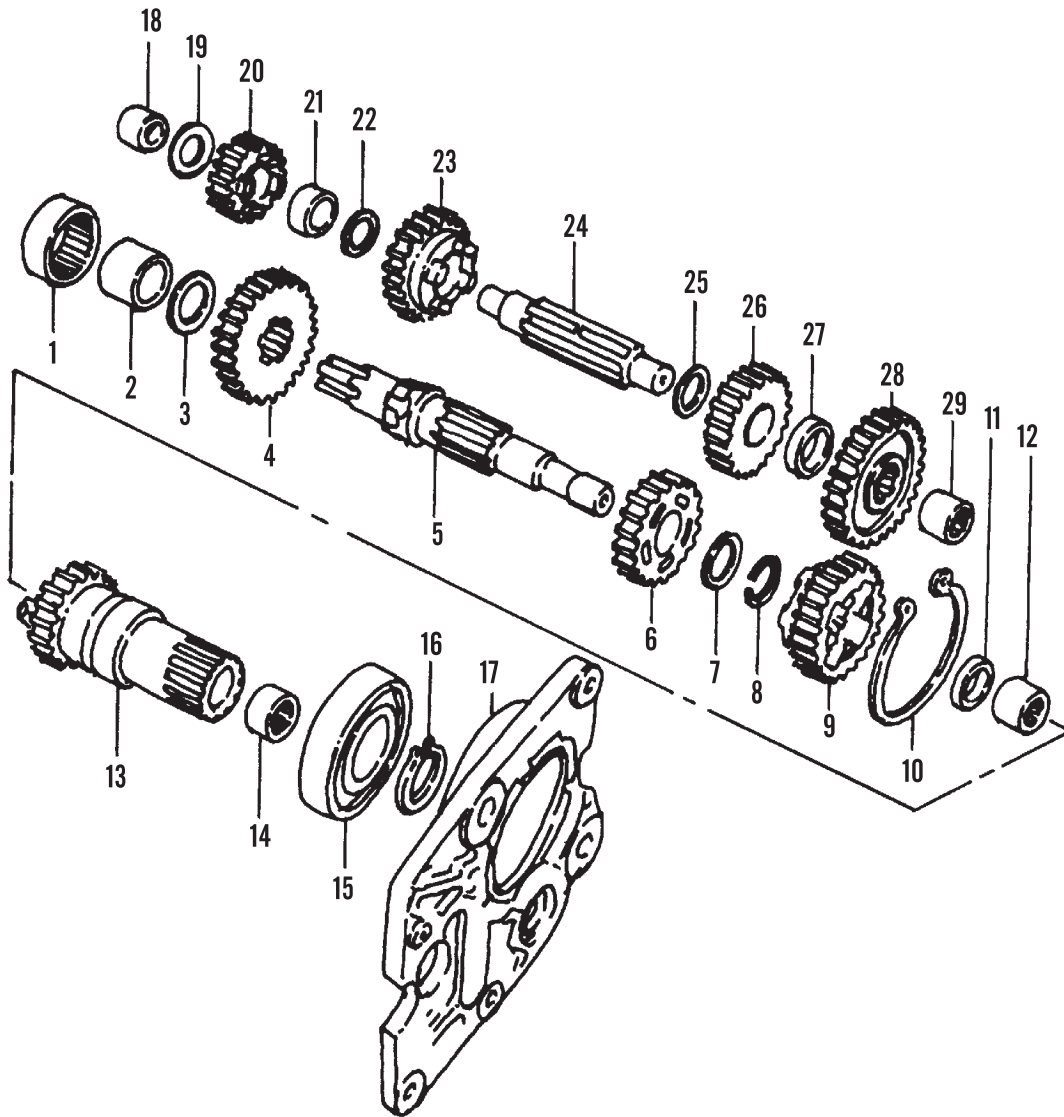

- | | |
|--------------------------|-------------------------------------|
| 1. Needle bearing | 16. Circlip |
| 2. Inner race | 17. Access cover |
| 3. Thrust washer | 18. Countershaft bearing closed end |
| 4. First mainshaft gear | 19. Washer |
| 5. Mainshaft | 20. First countershaft gear |
| 6. Third mainshaft gear | 21. Bearing |
| 7. Washer | 22. Washer |
| 8. Circlip | 23. Third countershaft gear |
| 9. Second mainshaft gear | 24. Countershaft |
| 10. Circlip | 25. Thrust washer |
| 11. Thrust washer | 26. Second countershaft gear |
| 12. Bearing | 27. Spacer |
| 13. Clutch gear | 28. Fourth countershaft gear |
| 14. Needle bearing | 29. Countershaft bearing open end |
| 15. Bearing | |

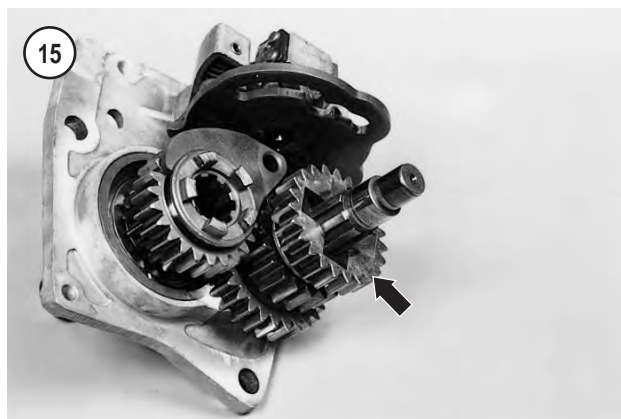
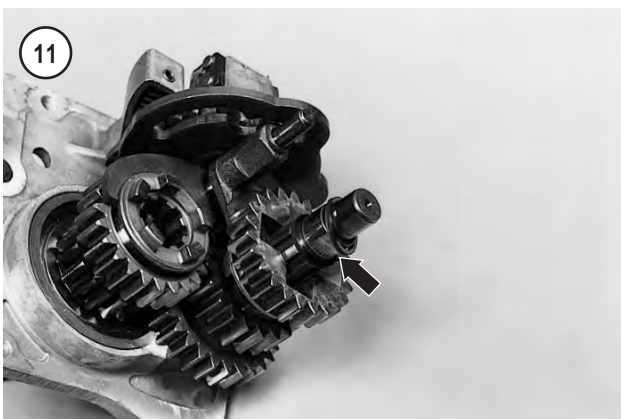
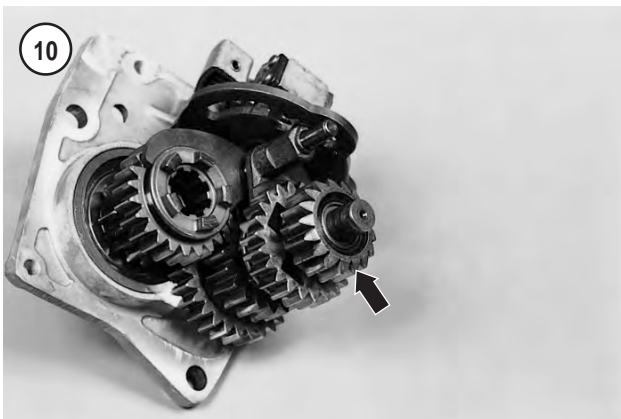
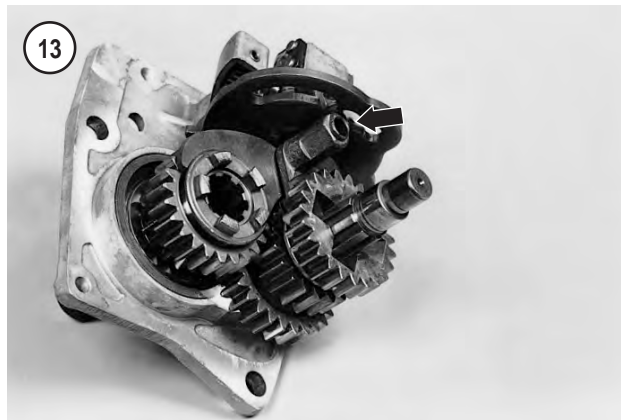
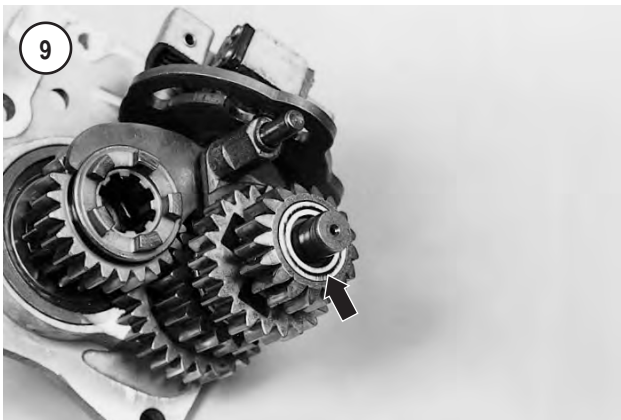
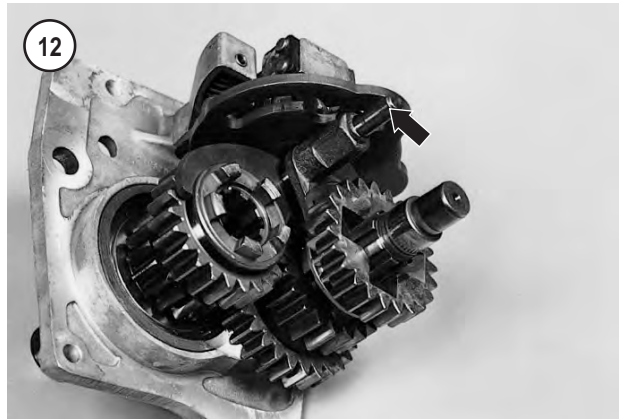
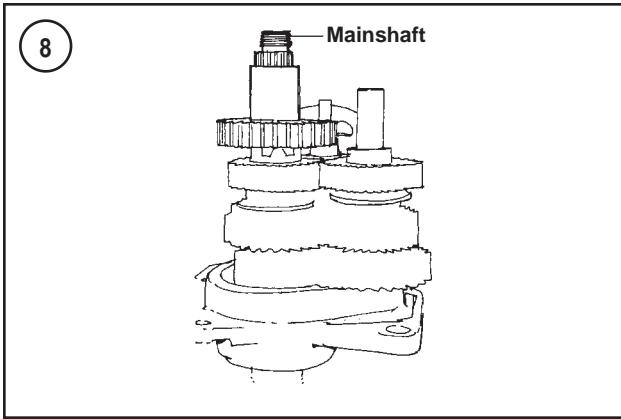

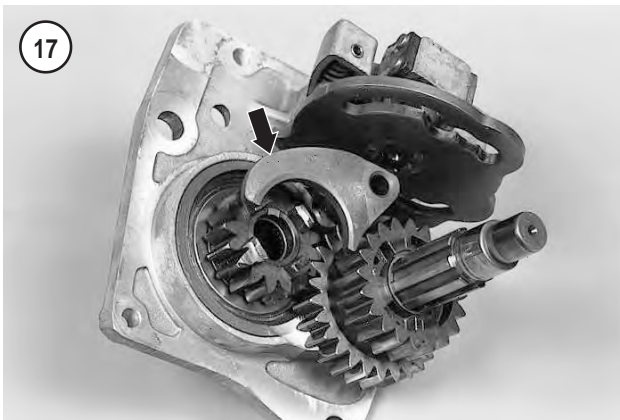

8. Remove the shift fork (**Figure 17**). Then remove the finger rollers (**Figure 14**) from the shift fork.
9. Pull the countershaft (**Figure 18**) from the access cover.
10. Remove the following from the countershaft:
 - a. Fourth gear (**Figure 19**).
 - b. Spacer (**Figure 20**).
 - c. Second gear (**Figure 21**).
 - d. Thrust washer (**Figure 22**).
11. Remove the following from the mainshaft:
 - a. Circlip (8, **Figure 7**).
 - b. Washer (7, **Figure 7**).
 - c. Third gear (6, **Figure 7**).
 - d. Thrust washer (3, **Figure 7**).

NOTE

To remove the mainshaft first gear (4, **Figure 7**), the bearing inner race (2) must be pressed off the shaft. Complete disassembly is only required for part replacement.

12. Support the first gear in a press. Then press against the mainshaft and remove the bearing inner race and first gear. First gear will be loose once the bearing inner race is free of the mainshaft.
13. Refer to **Figure 23**. Remove the clutch gear from the access cover as follows:
 - a. Remove the snap ring (**Figure 24**).



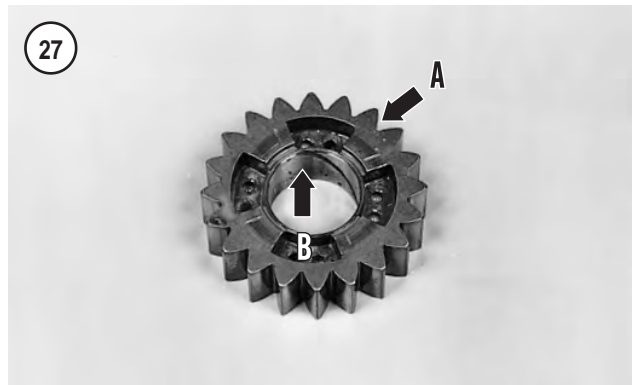
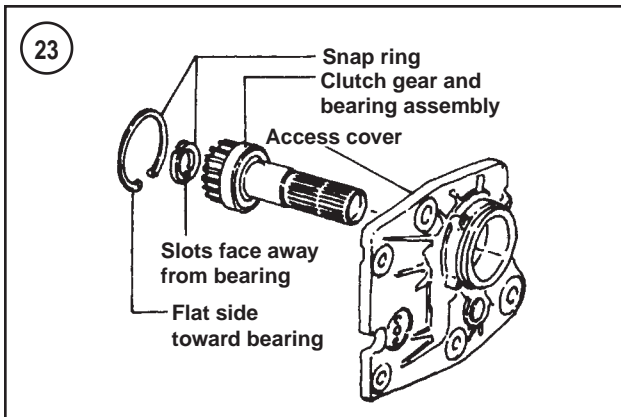

b. Tap the clutch gear shaft and bearing (**Figure 25**) out of the access cover. See **Figure 26**.



Transmission Inspection

1. Examine gears (A, **Figure 27**) for worn or chipped teeth, pitting, scoring or other damage. If the gears appear okay, make the following checks:

- a. Install the splined gears on their respective shafts and check for binding or excessive play (**Table 1**).
- b. Install stationary gears on their respective shafts and place them at their point of operation. Spin these gears and check for binding or rocking. Rocking is caused by excessive inside diameter bushing wear (B, **Figure 27**).
- c. Replace gears as necessary.

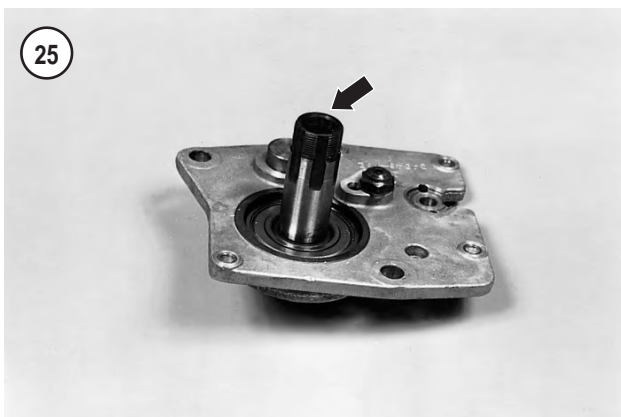

NOTE

*Early 1986 883 models use different transmission gears than later 1986 883 models. All 1100 models use the later type transmission gear sets. Only later type gears can be used in 1100 transmissions. The only way to determine which gear set is installed in a 1986 883 model is to measure the gears outside diameter as shown in **Figure 28** and compare the measurements to **Table 2**.*

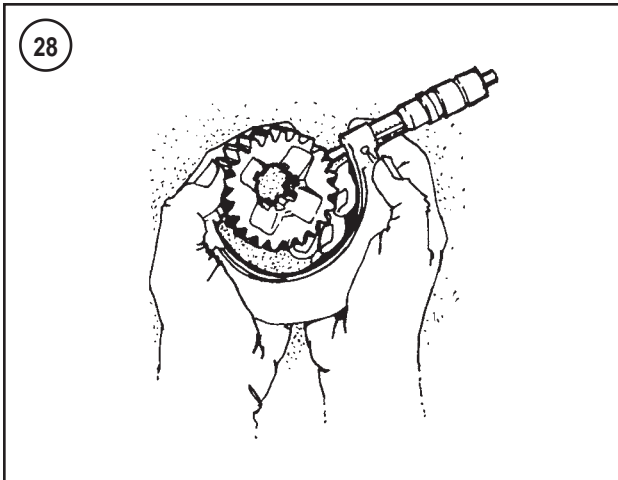
**NOTE**

When replacing a worn gear(s) it is advisable to also replace the mating gear(s) to prevent accelerated wear to the new gear(s).

NOTE

When replacing gears, note that all 1987 models are equipped with close ratio gears. To install close ratio gears in a 1986 model, refer to **Close Ratio Gear Installation** in this section.

2. Examine the dog clutches (**Figure 29**) for chips and rounded edges or wear.
3. Check the shafts (**Figure 30**) for worn splines and worn or damaged circlip grooves.

CAUTION

The needle bearings installed in the transmission gears, access cover and crankcase housing are press-fit. Replacement of these bearings requires a press or special bearing replacement tools. Driving in the bearings will damage them. If the proper tools are not available, refer replacement to a dealership.

4. Inspect the needle bearings for wear, needle damage or roughness. Replace the bearings if necessary.
5. Replace worn or damaged thrust washers.

CAUTION

Excessive transmission shaft runout will cause vibration and excessive gear wear.

6. Mount the mainshaft or countershaft in a suitable centering device. Rotate each shaft and measure bend with a dial indicator. Replace either shaft if it is bent more than 0.003 in. (0.08 mm).
7. Check the shift fork shaft for cracks, deep scoring or wear. Check the shaft for bending by rolling it on a piece of glass or other flat surface. If the forks do not roll smoothly, the shaft is bent.

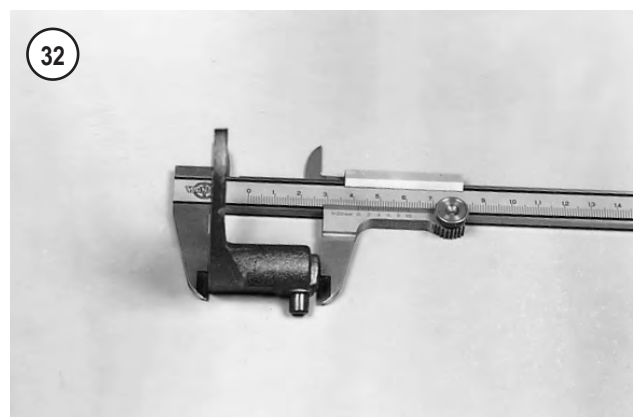

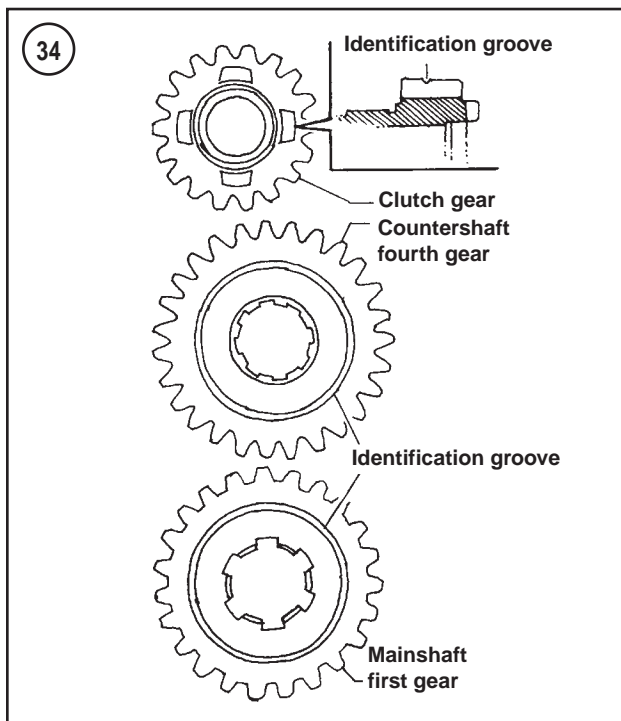
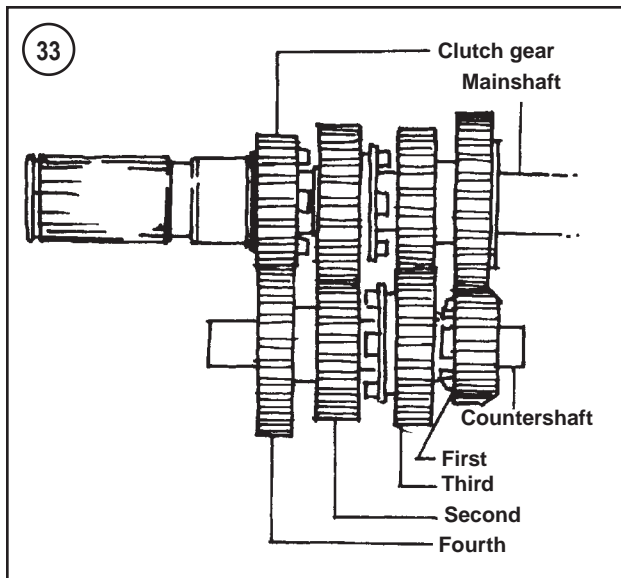

8. Check the shift forks (**Figure 31**) for cracks, deep scoring or excessive wear.
9. Shift fork length varies. If replacing a shift fork, be sure to replace it with one of the same length (**Figure 32**).

Close Ratio Gear Installation

An internal gear ratio change was made starting on 1987 models. All 1987-1990 models are installed with close ratio gears. Refer to **Table 3** for a complete listing of gear ratios. Owners of 1986 models who wish to install close ratio gears should note the following:

1. The close ratio gear set is composed of three new gears: mainshaft first gear, countershaft fourth gear and the clutch gear. See **Figure 33**.
2. Close ratio gears are identified with grooves machined into the face of the gears. **Figure 34** identifies the new gears and their markings. Note that the clutch gear will have its groove cut into the dog faces.
3. Refer to **Figure 33** and note the following installation conditions:
 - a. The new mainshaft first gear can be used with any 17-tooth countershaft first gear.
 - b. A new clutch gear and countershaft fourth gear must be installed as a pair.
 - c. Service and installation procedures remain the same as for 1986 models.

Access Cover Inspection/Bearing Replacement

CAUTION

The needle bearings installed in the transmission gears, access cover and crankcase housing are press-fit. Replacement of these bearings requires a press or special bearing replacement tools. Driving in the bearings will damage them. If the proper tools are not available, refer replacement to a dealership.

1. Check the clutch gear ball bearing (**Figure 35**).
2. Check the needle bearing (**Figure 36**) for wear or roughness.

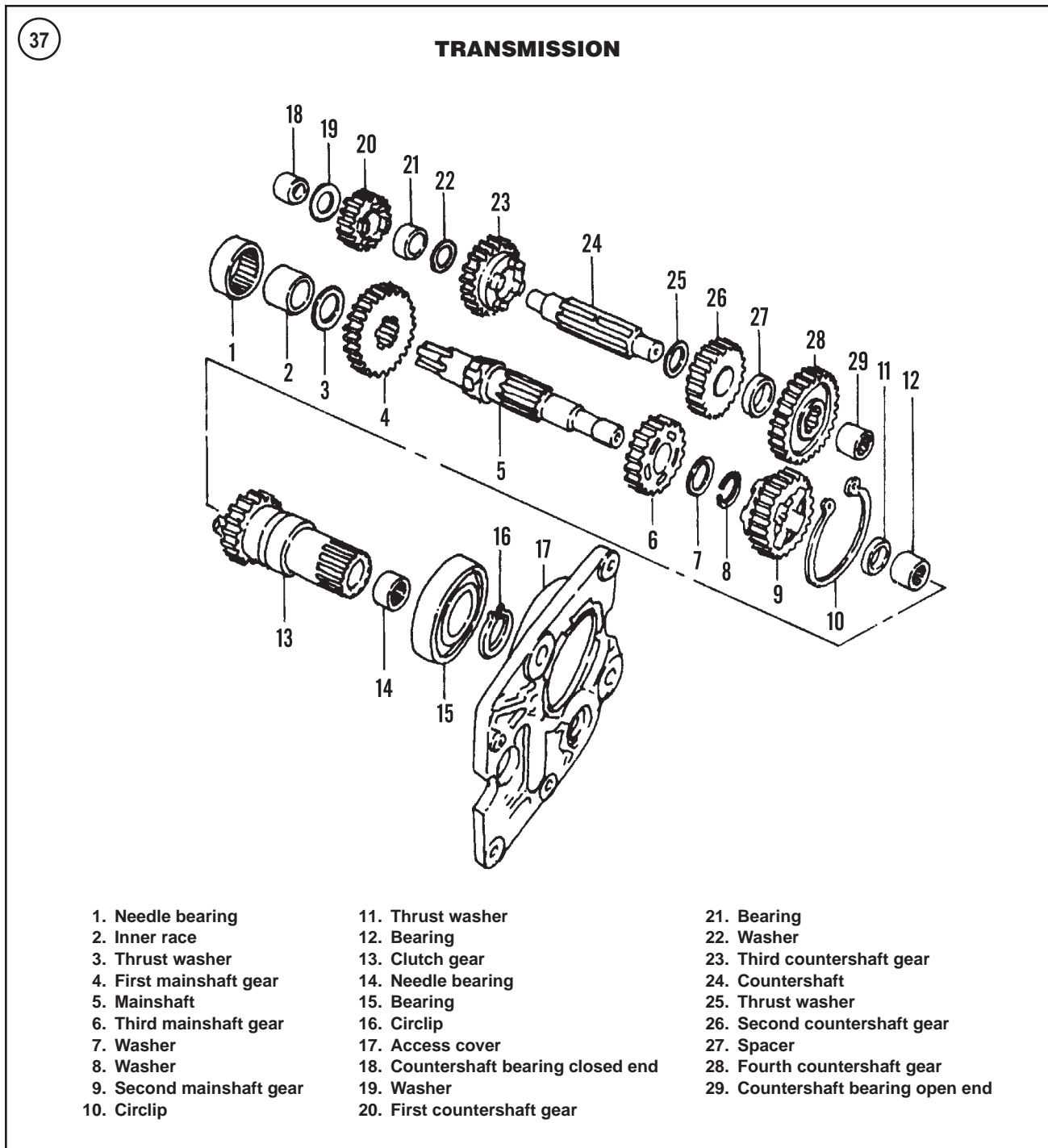
**NOTE**

Remove the circlip (16, **Figure 37**) before replacing the bearing (15).

CAUTION

Always install new circlips when reassembling the transmission and gear shifter assemblies.

3. Check the clutch gear ball bearing surface in the access cover for wear or damage. Replace the access cover if necessary.

Transmission Assembly

Refer to **Figure 37**.

1. Install the shift mechanism onto the access cover as described in this chapter.
2. Install the mainshaft thrust washer so that the grooves on the washer face toward the transmission.
3. Slide the clutch gear and bearing assembly through the access cover until the bearing bottoms on the cover shoulder.

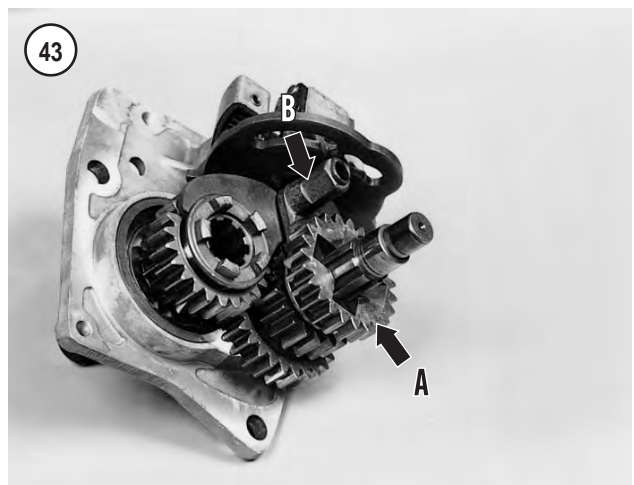

4. Install a new snap ring (**Figure 23**) so that the flat side faces the bearing.
5. Assemble the following components on the countershaft in the following order:
 - a. Second gear thrust washer (**Figure 22**).
 - b. Second gear (**Figure 21**).
 - c. Spacer (**Figure 20**).
6. Install the countershaft 4th gear so that the recess portion (**Figure 38**) faces toward the spacer. See **Figure 39**.
7. Make sure the countershaft second gear turns freely on countershaft.
8. Install the countershaft assembly (**Figure 40**) into the access cover so that the countershaft fourth gear engages with the mainshaft clutch gear.
9. Install a finger roller (**Figure 41**) on each shift fork stud.
10. Install the mainshaft second gear with its shift fork (**Figure 42**). Position the shift fork so that the finger roller stud faces toward the transmission access cover. Make sure the shift fork finger engages the gear slot.
11. Install the countershaft third gear (A, **Figure 43**) and corresponding shift fork (B). Engage the shift fork finger roller into the gear slot (**Figure 44**).

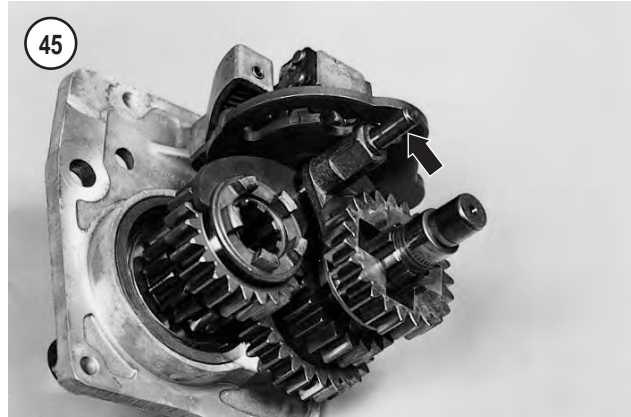
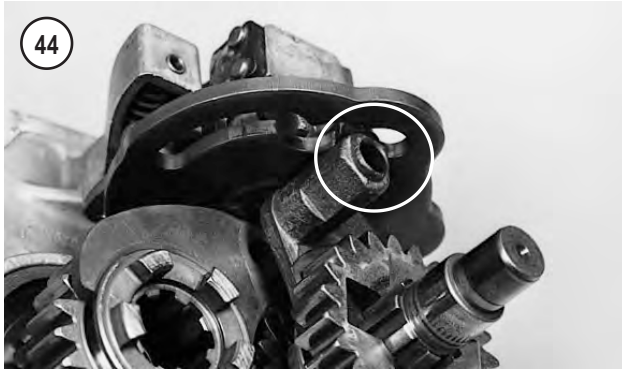

12. Install the shift fork shaft (**Figure 45**) so it passes through both shift forks and bottoms into the access cover. Make sure the shift forks engage the shifter cam after installing the shift fork shaft.

13. Install the variable washer (**Figure 46**) onto the countershaft.

14. Install the countershaft first gear (**Figure 47**) and the washer (**Figure 48**).

NOTE

If the inner race and first gear were not pressed off the mainshaft, proceed to Step 16.

15. Refer to **Figure 37**. If the inner race (2, **Figure 37**) and first gear (4) were pressed off of the mainshaft, perform the following:

- a. Slide first gear (4, **Figure 37**) on the mainshaft so that its oil retention groove faces toward the bearing inner race (2).
- b. Align the inner race over the mainshaft so that the letter side faces up. Press against this side only.
- c. Press the inner race (2, **Figure 37**) onto the mainshaft until it touches first gear.
- d. When the inner race is properly installed, the mainshaft first gear will have no end play. Check by attempting to twist the gear upward.
- e. Install the mainshaft thrust washer (3, **Figure 37**) over the inner race and against first gear.

16. Slide third gear (6, **Figure 37**) and its washer (7) onto the mainshaft. Install a new circlip (8, **Figure 37**) in the groove next to the washer (7).

17. Install the mainshaft assembly through second gear and into the clutch gear assembly. See **Figure 49**.

18. Perform the *Transmission Gear Spacing Check* as described in this section.

Transmission Gear Spacing Check

Measure transmission gear spacing using a feeler gauge and the transmission gear spacing tool (part No. HD-35820 [**Figure 50**]). **Figure 51** identifies the check points.

1. Slide the countershaft washer (19, **Figure 37**) and first gear (20) off the countershaft.

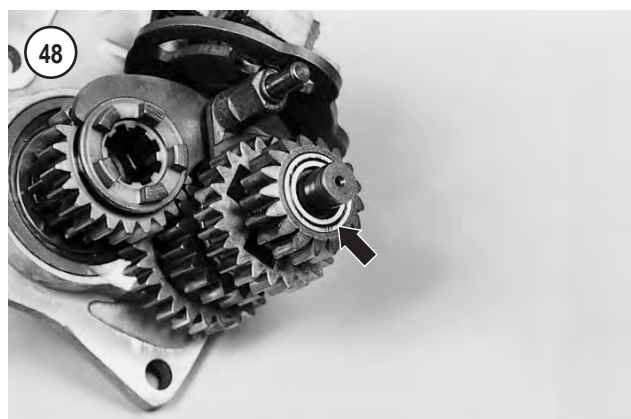
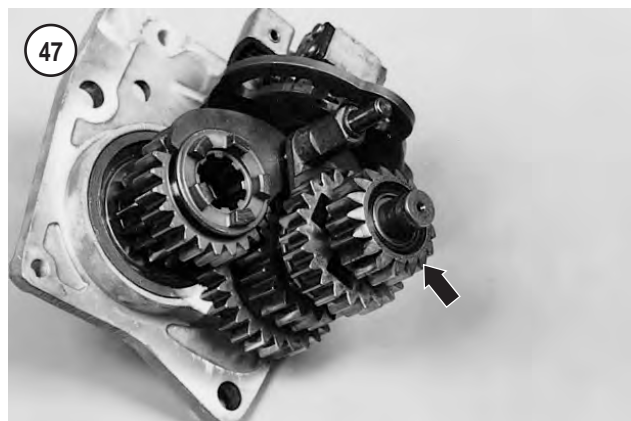
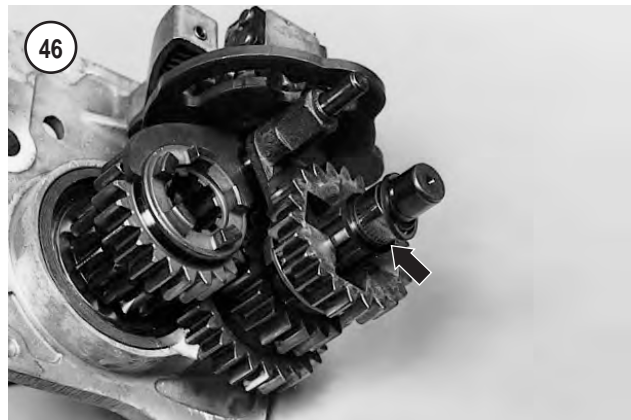

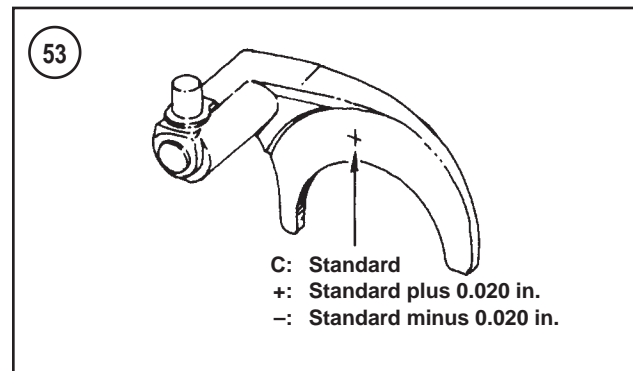
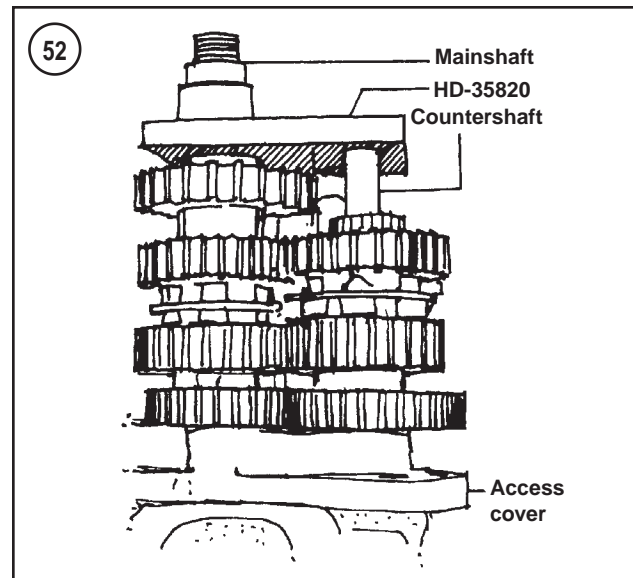
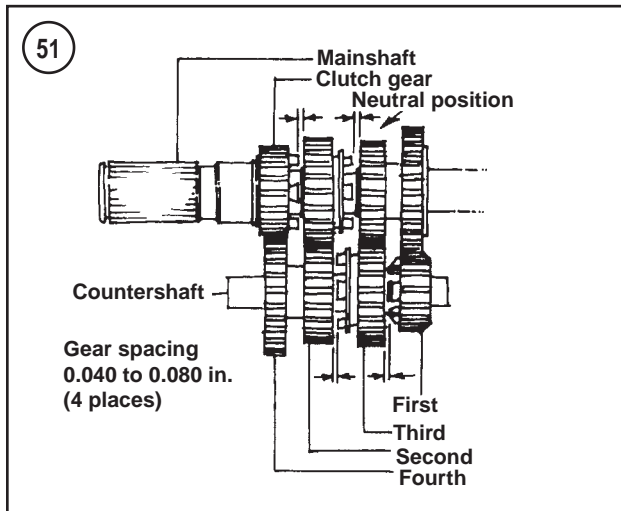
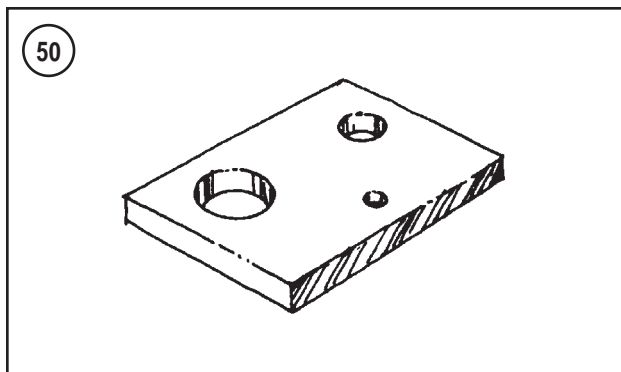
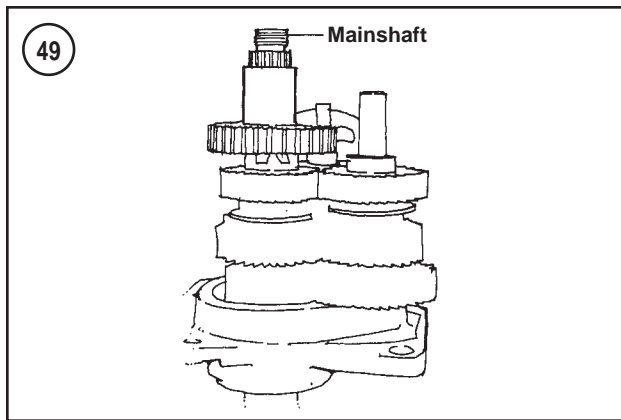

2. Place the access cover in a vise or support it on wood blocks so that the transmission shafts face up.
3. Align the transmission gear spacing tool holes with the mainshaft, countershaft and shift fork shaft holes and install the tool. Press down on the tool so that it is positioned as shown in **Figure 52**.
4. Shift the transmission into neutral.
5. Measure the minimum clearance between the mainshaft second gear and the clutch gear dogs using a 0.040 in. feeler gauge. The feeler gauge should move freely between the gears without moving them.

6. Insert a 0.080 in. feeler gauge between mainshaft third gear and the dogs on mainshaft second gear (**Figure 51**). The maximum limit is correct if the feeler gauge does not fit or if there is a slight drag when the feeler gauge is inserted and withdrawn.

7. Lift the mainshaft second gear shift fork and raise second gear. Make sure that the shift fork is flush against second gear. Then insert a 0.080 in. feeler gauge between mainshaft second gear and the clutch gear dogs (**Figure 51**). The maximum limit is correct if the feeler gauge does not fit or if there is a slight drag when the feeler gauge is inserted and withdrawn.

8. Repeat Step 7 and measure the clearance with a 0.040 in. feeler gauge. If the 0.040 feeler gauge is too tight, the minimum clearance is incorrect.

9. If any gear space checked in Steps 5-8 is incorrect, replace the mainshaft second gear shift fork. Shift forks are available in three sizes standard plus 0.020 in., standard, and standard minus 0.020 in. **Figure 53** identifies shift fork markings.

10. Shift the transmission into neutral.

11. Measure the minimum clearance between countershaft second gear and the third gear dogs (**Figure 51**) with a 0.040 in. feeler gauge. The feeler gauge should move freely between the gears without moving them.

12. Lift the countershaft third gear shift fork and raise third gear. Make sure that the shift fork is flush against second gear. Then insert a 0.080 in. feeler gauge between countershaft third gear and countershaft second gear (**Figure 51**). The maximum limit is correct if the feeler gauge does not fit or if there is a slight rag when the feeler gauge is inserted and withdrawn.

13. If any gear space checked in Step 11 and Step 12 is incorrect, replace the countershaft third gear shift fork. Shift forks are available in three sizes: standard plus 0.020 in., standard, and standard minus 0.020 in. **Figure 53** identifies shift fork markings.

14. Remove the transmission gear spacing tool (**Figure 52**) and turn it over. Align the tool holes with the mainshaft and shift fork shaft and install it (**Figure 54**).

15. Shift the transmission into neutral.

16. Measure from the top of countershaft third gear to the countershaft spline shoulder (**Figure 55**).

17. Compare the measurement taken in Step 16 with the measurements in **Table 4**. Then measure the countershaft washer (19, **Figure 37**) originally installed in your transmission and cross-reference it with the washer part numbers in **Table 5**. If the correct washer is used, the countershaft gear spacing is correct. If the washer is different, select the washer(s) from the list in **Table 4** that corresponds to the measurement taken in Step 16.

NOTE

*If the variable thrust washer is changed, check and reshim the countershaft end play as required. See **Mainshaft and Countershaft End Play Check and Adjustment** in this section.*

Mainshaft and Countershaft End Play Check and Adjustment

1. Temporarily install the assembled transmission assembly as described in the *Transmission Installation* in this section. It is not necessary to install the shift shaft.

2. Install the access cover bolts (**Figure 56**) and tighten to 14-19 ft.-lb. (19-26 N•m).

3. Install a dial indicator so that its tip rests against the end of the mainshaft on the clutch side of the engine. Move the mainshaft back and forth by hand and measure end play. Record the measurement.

4. Cross-reference the end play measurement taken in Step 3 with the list in **Table 6** and install the correct mainshaft thrust washer (3, **Figure 37**).

5. Install a dial indicator so that the tip rests against the end of the countershaft on the clutch side of the engine. Then bend a piece of strong wire or welding rod and wedge it into the hole in end of countershaft (clutch side). Push and pull countershaft and measure end play with a dial indicator. Record the measurement.

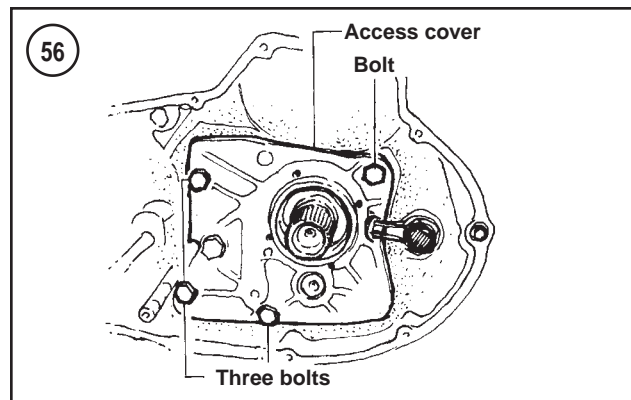
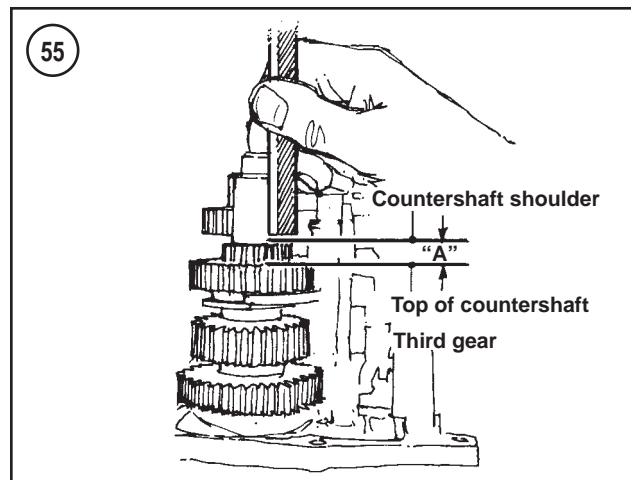
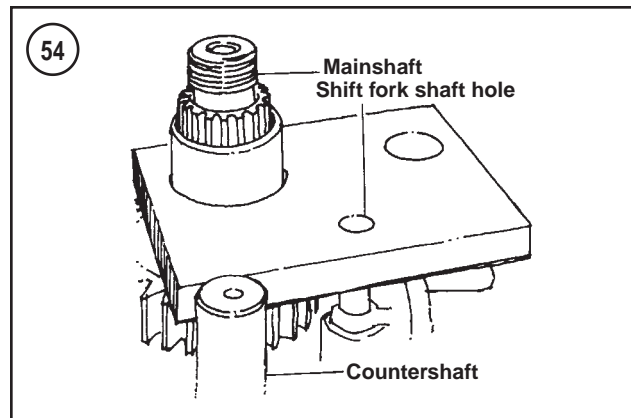

6. Cross-reference the end play measurement taken in Step 5 with the list in **Table 7** and install the correct variable fit-ness washer(s) (19, **Figure 37**).

7. Remove the transmission as described in this chapter and install the correct thrust washer(s) if necessary.

SHIFTER MECHANISM

Disassembly/Assembly

Refer to **Figure 57**.

57

SHIFTER MECHANISM

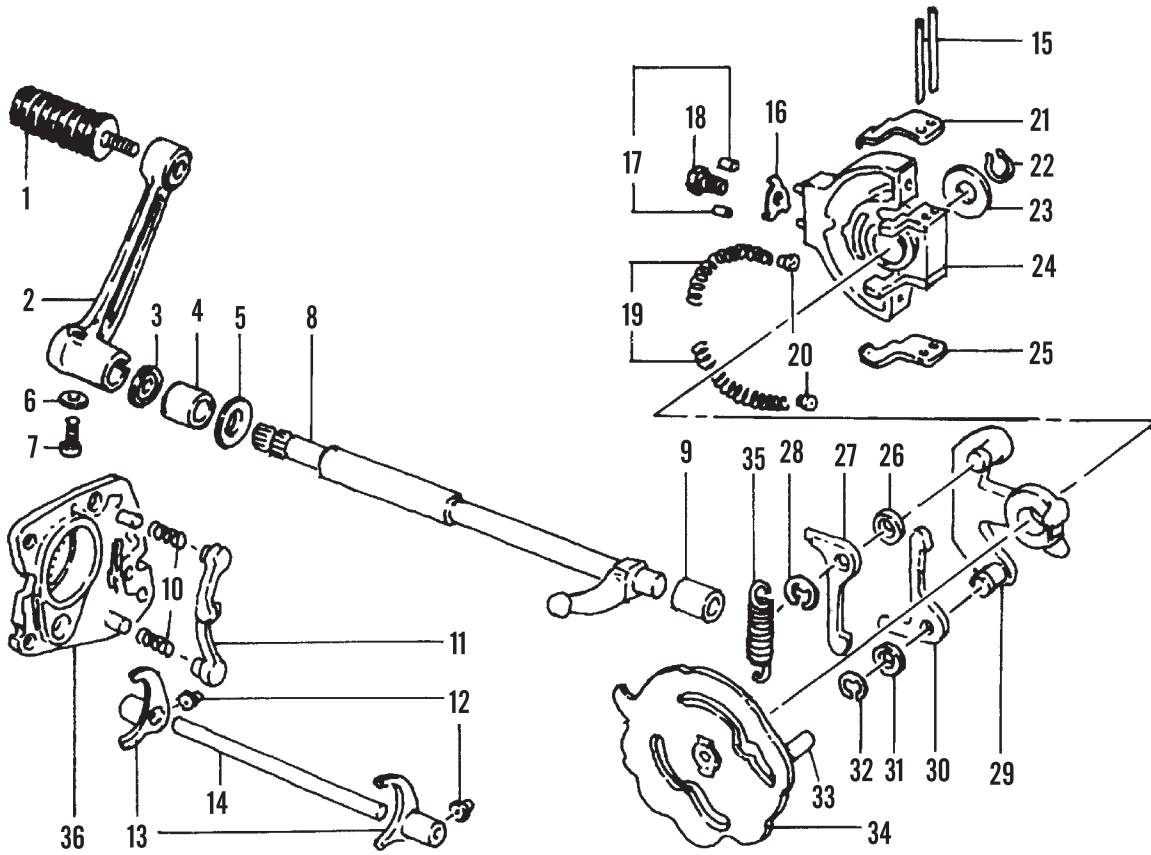

- | | |
|----------------------|-----------------------------------|
| 1. Lever | 19. Pawl carrier springs |
| 2. Shift lever | 20. Carrier spring retainer plugs |
| 3. Oil seal | 21. Upper pawl lifter arm |
| 4. Bushing | 22. Circlip |
| 5. Thrust washer | 23. Thrust washer |
| 6. Washer | 24. Pawl carrier support |
| 7. Screw | 25. Lower pawl lifter arm |
| 8. Shift lever | 26. Pawl spacer |
| 9. Bushing | 27. Pawl |
| 10. Spring | 28. E-clip |
| 11. Cam follower | 29. Pawl carrier |
| 12. Finger rollers | 30. Pawl |
| 13. Shift forks | 31. Spacer |
| 14. Shift fork shaft | 32. Retaining ring |
| 15. Pins | 33. Neutral switch pin |
| 16. Lockplate | 34. Shifter cam |
| 17. Cam support pin | 35. Pawl springs |
| 18. Cam capscrew | 36. Access cover |

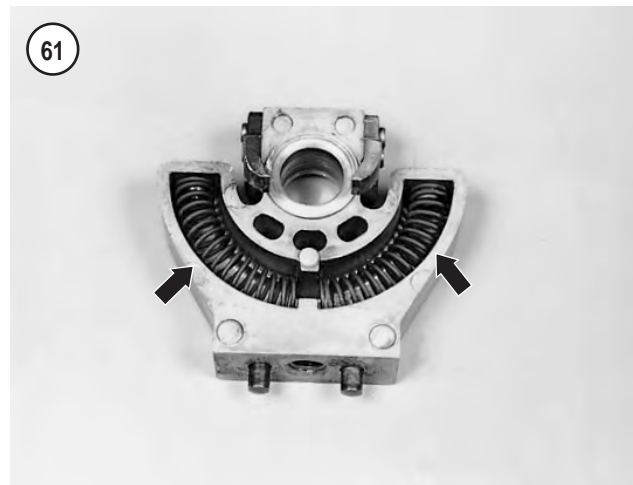
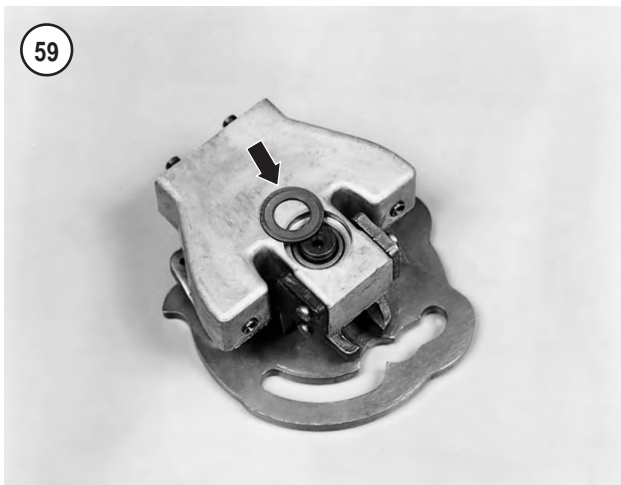
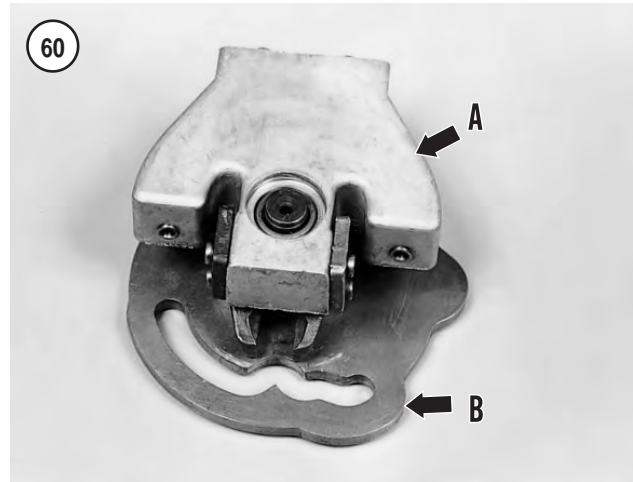
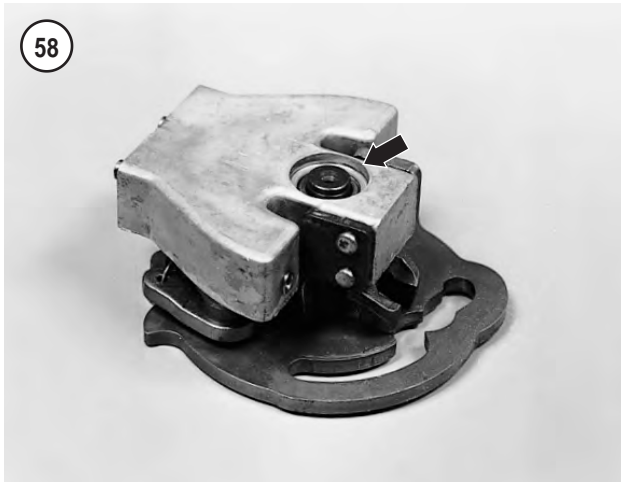

59

61

NOTE

Take careful note of location and orientation of each component as it is removed.

1. Remove the transmission and shift forks from the access cover as described in this chapter.

NOTE

It is not necessary to remove the clutch gear from the access cover when removing the shift mechanism.

2. Remove the cam capscrew (18, **Figure 57**) and lockplate (16) from the front of the access cover. Then remove the cam follower (11, **Figure 57**) and springs (10).

3. Lift the pawl carrier support (24, **Figure 57**) away from the access cover.

4. Remove the circlip (**Figure 58**) and thrust washer (**Figure 59**) from the outside of the pawl carrier support.

5. Lift the pawl carrier support (A, **Figure 60**) off of the shifter cam (B, **Figure 60**).

6. Remove the pawl carrier springs (**Figure 61**).

62

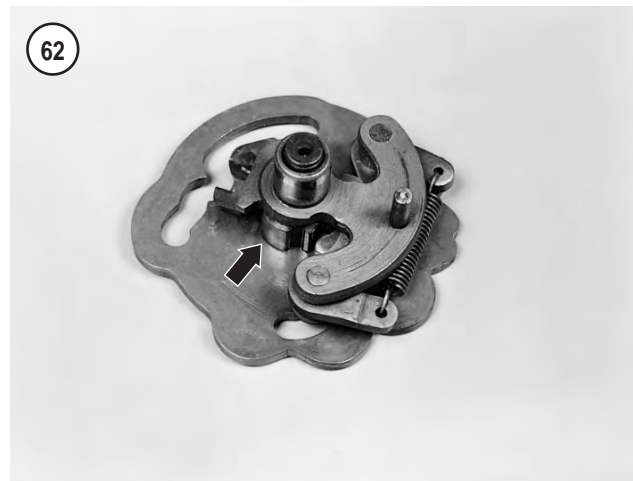

7. Remove the retainer plugs from the end of the pawl carrier springs (20, **Figure 57**).

8. Disassemble the pawl carrier as follows:

- a. Lift the pawl carrier (**Figure 62**) off of the shifter cam.
- b. Remove the E-clip (**Figure 63**) and remove the pawl spacer (**Figure 64**).

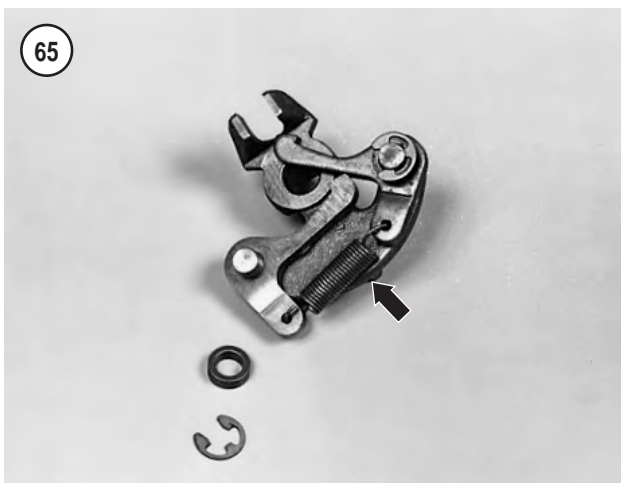
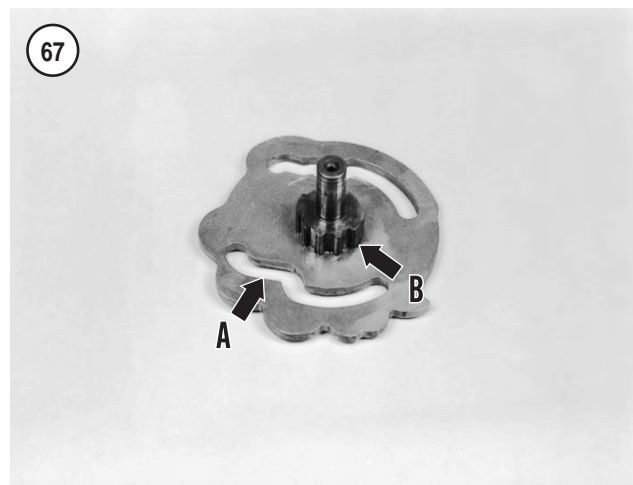

- c. Disconnect the pawl spring (**Figure 65**) and remove the pawl (**Figure 66**).
 - d. Repeat for the opposite pawl.
9. Inspect the shift mechanism as described in this section.
10. Assembly is the reverse of disassembly, noting the following.

- a. Install pawls on the pawl carrier, using spacers so that the spring hook holes align. Note that one spacer will be underneath the pawl and the other spacer will be on outside of the pawl. See 26 and 31, **Figure 57**. Retract one pawl at a time, then install the shifter cam into pawl carrier.
- b. Install the assembly into the pawl carrier support so that the ear of the pawl is between the ends of the pawl carrier springs.
- c. Install a new E-clip and washer.
- d. Make sure that the pawls engage the cam ratchet.

Inspection

1. Clean all parts in solvent, then blow dry.
2. Examine the shifter cam for worn or grooved cam slots (A, **Figure 67**). Excessive wear will result in difficult shifting.
3. Check the shifter cam gear (B, **Figure 67**) for wear or damage.
4. Examine the pawl carrier yoke (**Figure 68**) where it engages the lever arm shaft. A severely worn yoke will cause the transmission to jump out of gear.

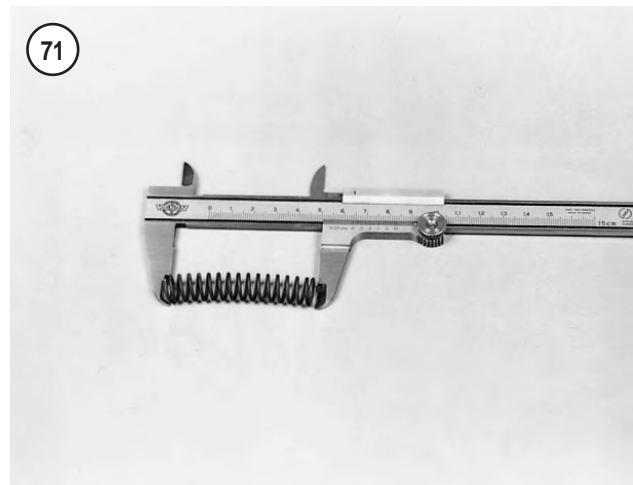
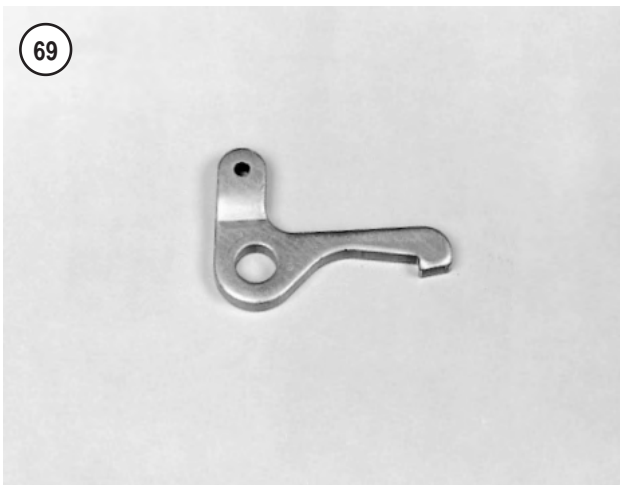
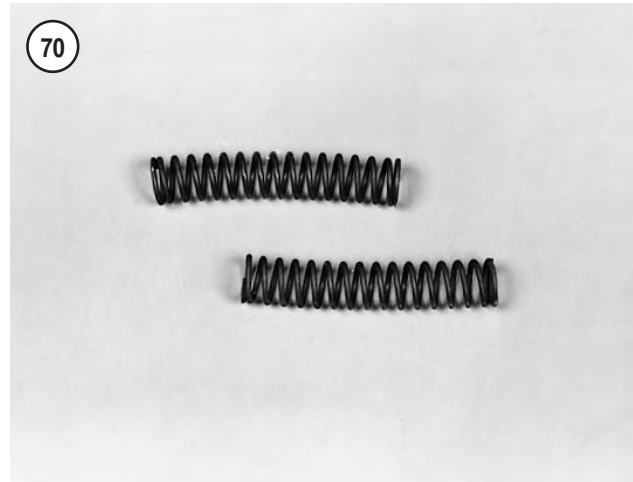

5. Replace the pawl spring(s) if it is longer than 1.75 in. (44.4 mm) between hooks.
6. Examine the shifter pawls (**Figure 69**) for grooves, cracks, wear or breaks. Replace if necessary.
7. Examine the pawl carrier springs (**Figure 70**) for fatigue or breaks. Replace them if they are shorter than 2.6562 in. (67.467 mm). See **Figure 71**.
8. Check the pawl carrier support (**Figure 72**) for breaks or minute surface cracks.
9. Check cam follower (11, **Figure 57**) for wear, especially on its thrust surfaces.
10. Check the shift lever for bending or wear.
11. Loosely assemble the shifter cam, pawl carrier and the pawl carrier support. After assembly, check bearing action for play.
12. Replace worn or damaged parts.

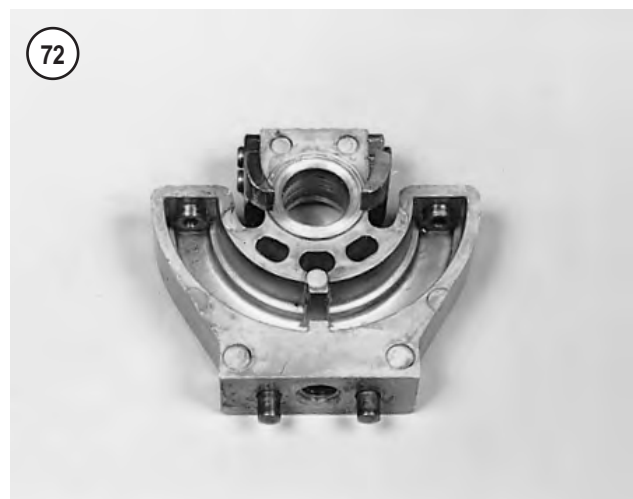

Table 1 TRANSMISSION SERVICE SPECIFICATIONS

| | New in. (mm) | Service Limit in. (mm) |
|---|----------------------------------|-----------------------------------|
| Clutch face clearance | | |
| Mainshaft 4th and 2nd gear | 0.040 (1.02) | 0.080 (2.03) |
| Mainshaft 3rd and 2nd gear | 0.040 (1.02) | 0.080 (2.03) |
| Clutch gear needle bearing journal diameter | 0.7495-0.7500 (19.037-19.050) | 0.7485 (19.012) |
| Countershaft | | |
| Needle bearing journal diameter | | |
| Access door | 0.7500-0.7495 (19.050-19.037) | 0.7490 (19.025) |
| Right crankcase side or end | 0.6875-0.6870 (17.463-17.450) | 0.6865 (17.437) |
| Countershaft end play | 0.004 (0.10) | 0.015 (0.38) |
| 1st gear needle bearing journal diameter | 0.6875-0.6870 (17.463-17.450) | 0.6865 (17.437) |
| Gear face clearance | | |
| Countershaft 1st and 3rd gear | 0.040 (1.02) | 0.080 (2.03) |
| Countershaft 2nd and 3rd gear | 0.040 (1.02) | 0.080 (2.03) |
| Mainshaft end play | 0.006 (0.15) | 0.020 (0.51) |
| Mainshaft 3rd gear end play | 0.006-0.020 (0.15-0.51) | |
| Mainshaft and countershaft runout | — | 0.003 (0.08) |

8

Table 2 EARLY AND LATE STYLE GEAR OUTSIDE DIAMETERS

| Gear | Number or teeth | Outside diameter in. (mm) |
|--------------------------|------------------------|--------------------------------------|
| Early style gears | | |
| Countershaft 2nd gear | 20 | 2.448-2.452 (62.18-62.28) |
| Countershaft 3rd gear | 23 | 2.648-2.657 (67.26-67.49) |
| Mainshaft 2nd gear | 23 | 2.648-2.657 (67.26-67.49) |
| Mainshaft 3rd gear | 20 | 2.448-2.452 (62.18-62.28) |
| Late style gears | | |
| Countershaft 2nd gear | 20 | 2.423-2.428 (61.54-61.67) |
| Countershaft 3rd gear | 23 | 2.622-2.627 (66.60-66.73) |
| Mainshaft 2nd gear | 23 | 2.622-2.627 (66.60-66.73) |
| Mainshaft 3rd gear | 20 | 2.423-2.428 (61.54-61.67) |

Table 3 GEAR RATIOS

| | 1986 models | 1987-1990 models |
|-----------------------------|--------------------|-------------------------|
| Internal gear ratios | | |
| 1st | 2.52 | 2.29 |
| 2nd | 1.82 | 1.66 |
| 3rd | 1.38 | 1.25 |
| 4th | 1.00 | 1.00 |

(continued)

Table 3 GEAR RATIOS (continued)

| | 1986 models | 1987-1990 models |
|---------------------|-------------|------------------|
| Overall gear ratios | | |
| 1st | 10.00 | 9.12 |
| 2nd | 7.25 | 6.59 |
| 3rd | 5.48 | 4.98 |
| 4th | 3.97 | 3.97 |

Table 4 COUNTERSHAFT GEAR SPACER SELECTION CHART

| Measurement (in.) | Number of washers | Part No. |
|-------------------|-------------------|----------|
| 0.335-0.339 | 1 | 35860-86 |
| 0.330-0.334 | 2 | 35865-86 |
| 0.325-0.329 | 1 | 35865-86 |
| | 1 | 35864-86 |
| 0.320-0.324 | 1 | 35865-86 |
| | 1 | 35863-86 |
| 0.315-0.319 | 1 | 35864-86 |
| | 1 | 35863-86 |
| 0.310-0.314 | 2 | 35863-86 |
| 0.305-0.309 | 1 | 35863-86 |
| | 1 | 35862-86 |
| 0.300-0.304 | 1 | 35863-86 |
| | 1 | 35861-86 |
| 0.295-0.299 | 1 | 35862-86 |
| | 1 | 35861-86 |
| 0.290-0.294 | 2 | 35861-86 |
| 0.285-0.289 | 1 | 35861-86 |
| | 1 | 35860-86 |
| 0.280-0.284 | 2 | 35860-86 |
| 0.275-0.279 | 1 | 35864-86 |
| | 2 | 35863-86 |
| 0.270-0.274 | 3 | 35863-86 |
| 0.265-0.269 | 2 | 35863-86 |
| | 1 | 35862-86 |
| 0.260-0.264 | 1 | 35863-86 |
| | 2 | 35862-86 |
| 0.255-0.259 | 1 | 35864-86 |
| | 2 | 35861-86 |
| 0.250-0.254 | 1 | 35863-86 |
| | 2 | 35861-86 |
| 0.245-0.249 | 1 | 35862-86 |
| | 2 | 35861-86 |
| 0.240-0.244 | 3 | 35861-86 |
| 0.235-0.239 | 2 | 35861-86 |
| | 1 | 35860-86 |

Table 5 COUNTERSHAFT WASHERS

| Thickness | Part No. |
|-----------|----------|
| 0.055 in. | 35860-86 |
| 0.050 in. | 35861-86 |
| 0.045 in. | 35862-86 |
| 0.040 in. | 35863-86 |
| 0.035 in. | 35864-86 |
| 0.030 in. | 35865-86 |

Table 6 MAINSHAFT END PLAY THRUST WASHER SELECTION

| End play | Washer thickness | Part No. |
|-----------------|------------------|----------|
| 0.114-0.108 in. | 0.099-0.094 in. | 35380-84 |
| 0.107-0.102 in. | 0.093-0.088 in. | 35381-84 |
| 0.101-0.097 in. | 0.087-0.082 in. | 35382-84 |
| 0.096-0.092 in. | 0.082-0.077 in. | 35383-84 |
| 0.091-0.086 in. | 0.081-0.070 in. | 35384-84 |
| 0.085-0.079 in. | 0.070-0.065 in. | 35385-84 |

Table 7 COUNTERSHAFT END PLAY THRUST WASHER SELECTION

| Measurement (in.) | Number of washers | Part No. |
|-------------------|-------------------|----------|
| 0.172-0.176 | 3 | 35860-86 |
| 0.167-0.171 | 1 | 35861-86 |
| | 2 | 35860-86 |
| 0.162-0.166 | 1 | 35860-86 |
| | 2 | 35861-86 |
| 0.157-0.161 | 3 | 35861-86 |
| 0.152-0.156 | 1 | 35862-86 |
| | 2 | 35861-86 |
| 0.147-0.151 | 2 | 35862-86 |
| | 1 | 35861-86 |
| 0.142-0.146 | 3 | 35862-86 |
| 0.137-0.141 | 1 | 35863-86 |
| | 2 | 35862-86 |
| 0.132-0.136 | 2 | 35863-86 |
| | 1 | 35862-86 |
| 0.127-0.131 | 3 | 35863-86 |
| 0.122-0.126 | 1 | 35864-86 |
| | 2 | 35863-86 |
| 0.117-0.121 | 2 | 35860-86 |
| 0.112-0.116 | 1 | 35861-86 |
| | 1 | 35860-86 |
| 0.107-0.111 | 2 | 35861-86 |
| 0.102-0.106 | 1 | 35862-86 |
| | 1 | 35861-86 |
| 0.097-0.101 | 2 | 35862-86 |
| 0.092-0.096 | 1 | 35863-86 |
| | 1 | 35862-86 |
| 0.087-0.091 | 2 | 35863-86 |
| 0.082-0.086 | 1 | 35863-86 |
| | 1 | 35864-86 |
| 0.077-0.081 | 2 | 35864-86 |
| 0.072-0.076 | 1 | 35865-86 |
| | 1 | 35864-86 |
| 0.067-0.071 | 2 | 35865-86 |
| 0.062-0.066 | 1 | 35860-86 |
| 0.057-0.061 | 1 | 35861-86 |
| 0.052-0.056 | 1 | 35862-86 |
| 0.047-0.051 | 1 | 35863-86 |
| 0.042-0.046 | 1 | 35864-86 |

8

Table 8 TRANSMISSION TORQUE SPECIFICATIONS

| | ft.-lb. | in.-lb. | N•m |
|--------------------------------|---------|---------|-------|
| Transmission access door bolts | 14-19 | – | 19-26 |

CHAPTER NINE

FIVE-SPEED TRANSMISSION (1991-2003 MODELS)

This chapter covers the five-speed transmission, internal gearshift assemblies and shift mechanism. **Tables 1** and **Table 2** are at the end of this chapter.

When the clutch is engaged, the mainshaft is driven by the clutch hub, which is driven by the primary chain sprocket/clutch outer housing. Power flows from the mainshaft through the selected gear combination to the countershaft, which drives the main drive gear and transmission sprocket.

To gain access to the transmission and internal shift mechanism, it is not necessary to remove the engine or disassemble the crankcase. The transmission components are contained behind an access door on the left crankcase half.

TRANSMISSION

Removal

Refer to **Figure 1**.

1. Remove the exhaust system (Chapter Eleven).
2. Drain the transmission oil (Chapter Three).
3. Remove the drive sprocket and drive chain or belt (Chapter Thirteen).
4. Remove the engine sprocket, clutch and primary drive chain (Chapter Eight).
5. Shift the transmission into first gear.

6. Disconnect the detent lever spring (**Figure 2**) from the post groove.

7. Remove the snap ring (A, **Figure 3**) from the groove in the end of the shift drum. Discard the snap ring as a new one must be installed during reassembly.

8. Slide the detent plate (B, **Figure 3**) off the shift drum pins.

9. Loosen the two shift shaft locknuts (A, **Figure 4**). Then remove the locknuts and washers.

10. Remove the shift shaft assembly (B, **Figure 4**) from the crankcase.

11. Remove the countershaft retainer screw (**Figure 5**). Then remove the screw and countershaft retainer collar (**Figure 6**).

12. Remove the transmission access door mounting bolts (**Figure 7**).

13. Remove the access door with the transmission and shift mechanism attached. See **Figure 8**.

14. Remove the two dowel pins (**Figure 9**).

15. If further disassembly is necessary, perform the following as described in this chapter:

a. *Shift Forks and Shift Drum.*

b. *Mainshaft and Countershaft.*

16. If necessary, remove the main drive gear as described in *Main Drive Gear* in this chapter.

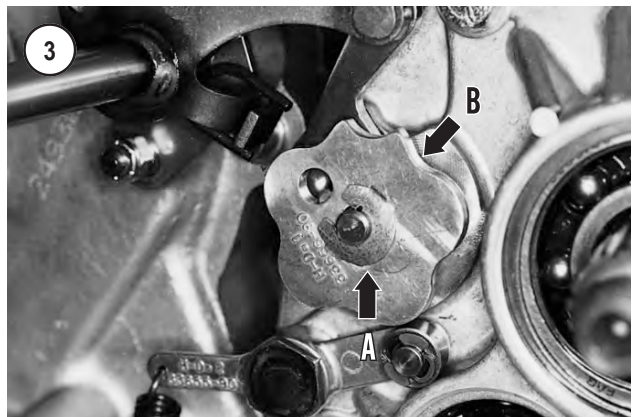
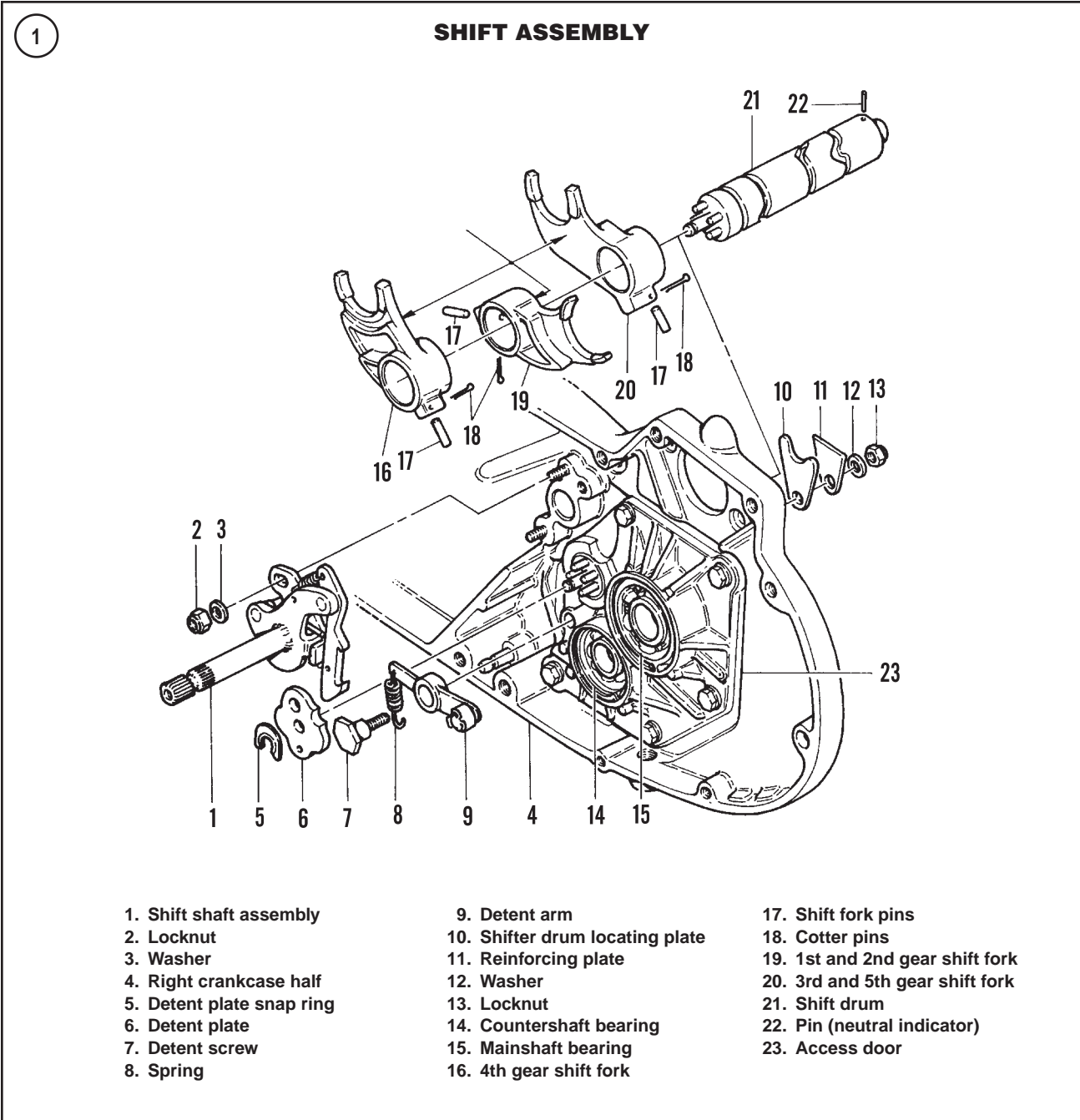

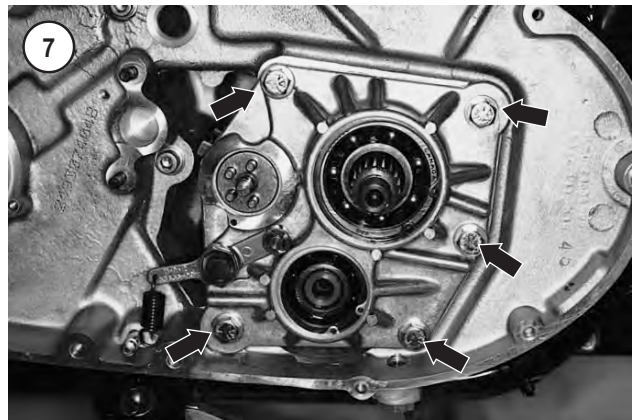

Inspection

1. Clean the transmission cavity (**Figure 9**) with cleaning solvent and dry with compressed air.
2. Inspect the access door bearings as described in this chapter.
3. Remove all thread sealant residue from the drive sprocket nut and main drive gear threads.

Installation

A No. 32 (0.116 in.) drill bit will be required when installing the transmission assembly.

Refer to **Figure 1**.

1. If the shift forks, shift drum and transmission were removed and disassembled, assemble them onto the access door as described in the following sections in this chapter:
 - a. *Mainshaft and Countershaft.*
 - b. *Shift Forks and Shift Drum Assembly.*
2. If removed, install the main drive gear as described in *Main Drive Gear* in this chapter.
3. Lubricate the transmission gears and shifter assembly with new transmission oil prior to installation.
4. Install the two dowel pins (**Figure 9**), if removed.
5. Align the transmission assembly with the access door opening and install the transmission/shifter assembly (**Figure 8**) while noting the following:

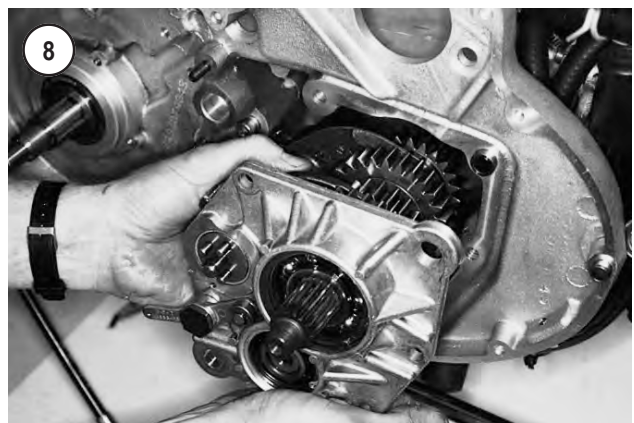

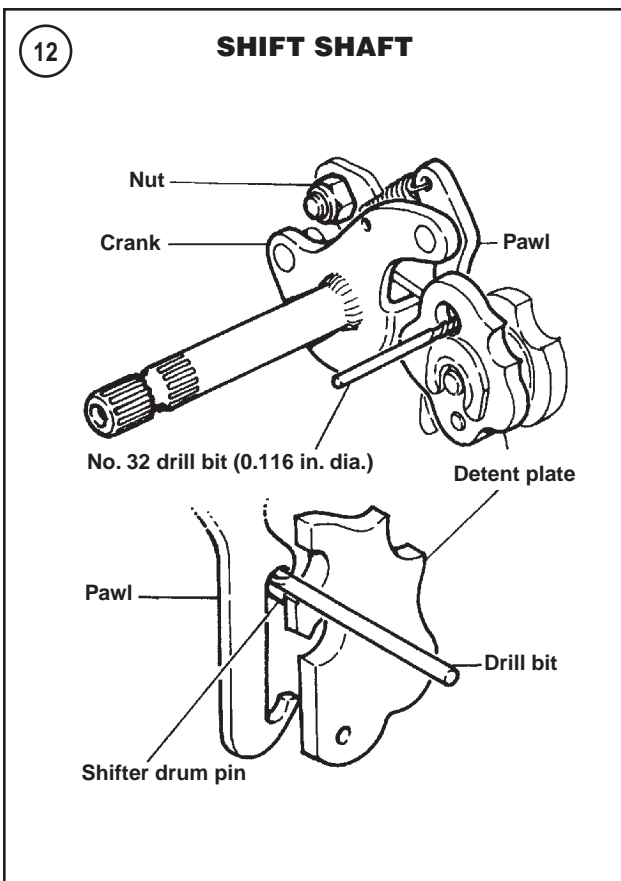
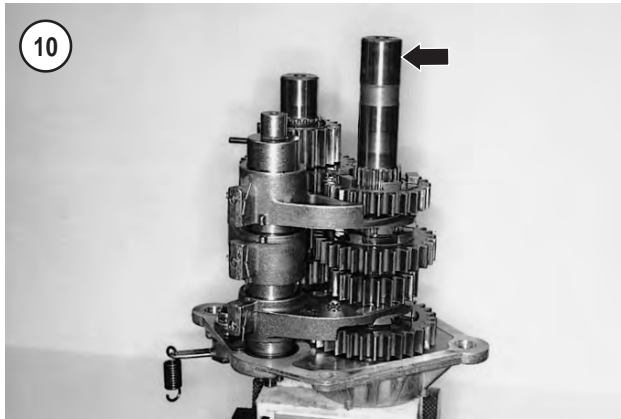

- a. The mainshaft (**Figure 10**) should enter fifth gear (**Figure 11**).
 - b. The drum shift shaft and countershaft should enter their respective crankcase bearings.
6. Apply threadlock (Loctite 242 or equivalent) to the transmission access door mounting bolts prior to installation. Install the bolts (**Figure 7**) and washers and tighten to 156-204 in.-lb. (18-23 N•m).
7. Install the countershaft retainer collar (**Figure 5**) as follows:
- a. The retainer collar has one flat side and one beveled side.
 - b. Install the retainer collar, with its beveled side facing out, onto the countershaft (**Figure 6**).
 - c. Shift the transmission into first gear.
 - d. Apply threadlock (Loctite 242 or equivalent) onto the retainer collar screw prior to installation. Install the countershaft retainer collar screw and tighten to 156-204 in.-lb. (18-23 N•m).
8. Install the shift shaft assembly by first lifting the shift pawl (**Figure 12**) over the shift drum pins and then aligning the shift shaft mounting holes with the two crankcase studs (A, **Figure 4**). Install the washers and nuts (A, **Figure 4**); hand tighten the nuts only.
9. Connect the detent arm spring onto the post groove as shown in **Figure 2**.
10. Make sure the shift pawl spring is connected to the pawl (**Figure 13**).
11. Install the detent plate onto the shift drum, aligning the holes in the plate with the pins in the drum (**Figure 14**).
12. Install a new detent plate snap ring (**Figure 15**) into the groove in the end of the shift drum. Use the installation tool (TRUARC part No. PR-0310 or equivalent) to install the new snap ring. Make sure the snap ring is correctly seated in the shift drum groove.
13. Adjust the shifter pawl as follows:
- a. Shift the transmission into third gear.
 - b. Install a No. 32 drill bit (0.116 in.) through the hole in the detent plate and between the shift pawl and drive pin at the end of the shift drum shaft as shown in **Figure 12** and A, **Figure 16**.



NOTE

Pressing down on the shift shaft crank helps to align the shift pawl with the shift drum pins. However, do not push excessively as this may cause the shift drum to rotate.

- c. Press down on the top of the shift shaft crank (**Figure 12**) to remove all clearance between the drill bit and shift pawl.
 - d. While applying pressure to the shift shaft crank, tighten the lower shift shaft locknut (B, **Figure 16**) to 90-110 in.-lb. (10-12 N•m).
 - e. Tighten the upper shift shaft nut (C, **Figure 16**) to 90-110 in.-lb. (10-12 N•m).
 - f. Remove the drill bit.
14. Install the engine sprocket, clutch and primary drive chain (Chapter Eight).
 15. Refill the transmission oil (Chapter Three).
 16. Install the drive sprocket and the drive chain or drive belt (Chapter Thirteen).
 17. Install the exhaust system (Chapter Eleven).
 18. Start the engine and check for oil leaks.
 19. Test drive the motorcycle slowly, checking that the transmission shifts properly.

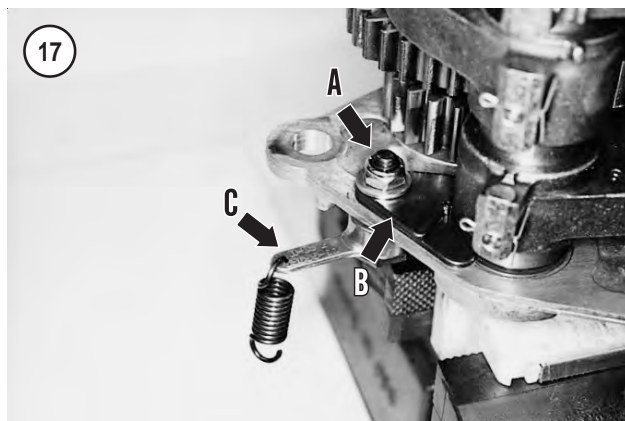
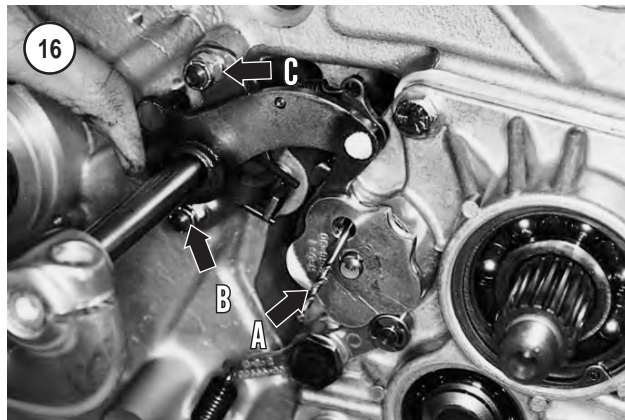

SHIFT FORKS AND SHIFT DRUM

Disassembly

Refer to **Figure 1**.

1. Remove the transmission assembly as described in *Transmission* in this chapter.
2. Secure the transmission access door in a vise with soft jaws. Then remove the following parts:
 - a. Detent nut and washer (A, **Figure 17**).
 - b. Reinforcing plate (B, **Figure 17**).
 - c. Detent screw, arm and spring (C, **Figure 17**).
 - d. Shift drum locating plate (**Figure 18**).
3. Remove the cotter pin (**Figure 19**) from each shift fork. Discard the cotter pins.
4. Remove the shift fork pin from each shift fork (**Figure 20**).



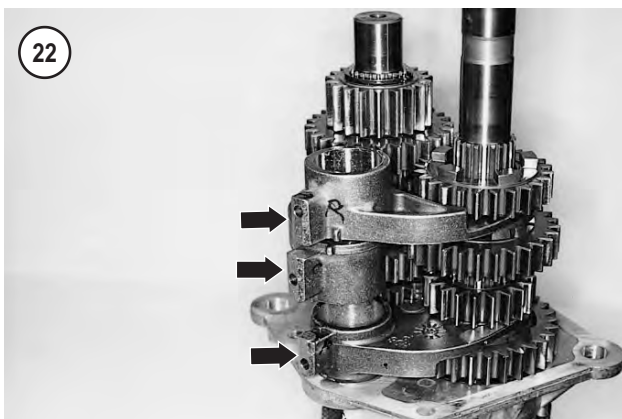
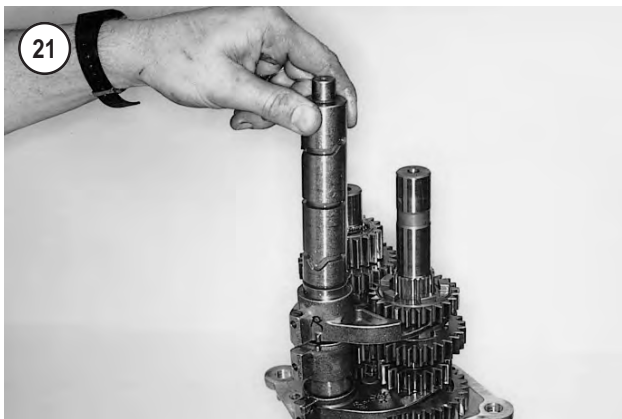
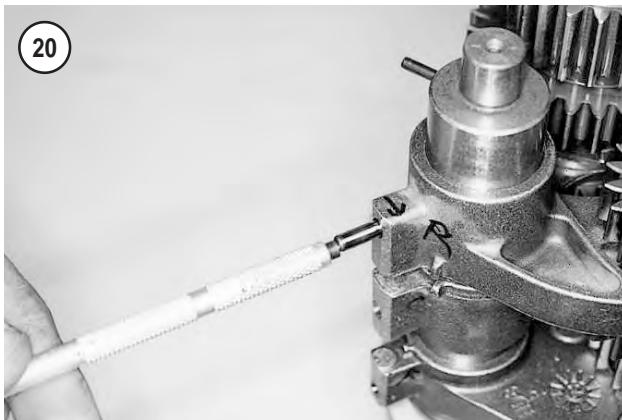
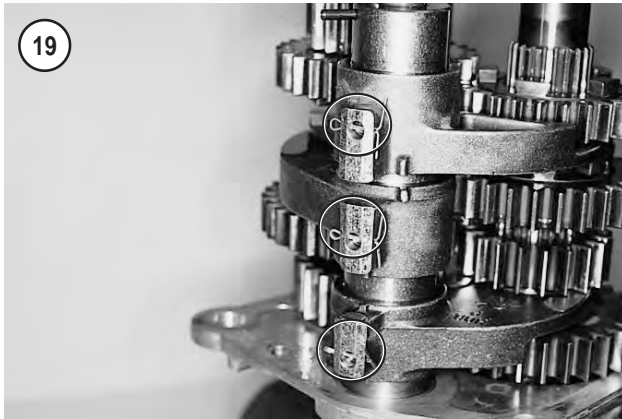

5. Slide the shift drum (Figure 21) out of the access door and remove it.
6. Remove the three shift forks (Figure 22).

Inspection

1. Clean all of the parts in solvent, except the access door bearings, and dry with compressed air.
2. Inspect each shift fork (Figure 23) for severe wear, cracks, bending or other damage. Check that each shift fork slides on the shift drum smoothly (Figure 24).
3. Check for any arc-shaped wear or burned marks on the shift forks. This wear pattern indicates that the shift fork has come in contact with the gear. The fork fingers have become excessively worn and the fork must be replaced.
4. Check the shift drum grooves (A, Figure 25) for wear or roughness. If any groove profile shows excessive wear or damage, replace the shift drum.
5. Check the shift drum pins (Figure 26) for cracks or severe wear.
6. Check the shift fork pins for cracks or severe wear.
7. Roll the shift drum on a flat surface, such as a piece of plate glass, and check it for any warp or damage.
8. Inspect the shift shaft assembly (Figure 27) for the following defects:
 - a. Bent shift shaft (A, Figure 27).
 - b. Damaged shift shaft splines (B, Figure 27).

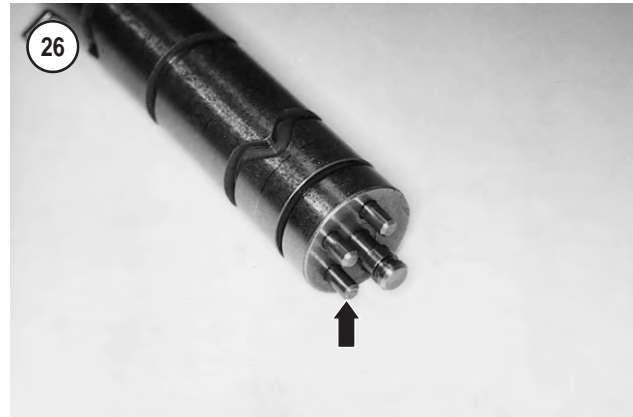
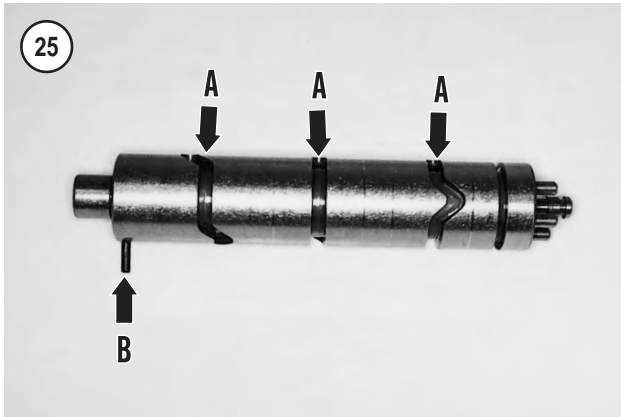

- c. Worn or damaged shift pawl (**Figure 28**).
 - d. Weak or damaged return springs.
9. Inspect the detent arm assembly (**Figure 29**) for the following defects:
- a. Worn or damaged detent screw (A, **Figure 29**).
 - b. Worn or damaged detent arm (B, **Figure 29**).
 - c. Worn or damaged shift drum locating plate (C, **Figure 29**).
 - d. Worn or damaged reinforcing plate (D, **Figure 29**).
10. Check the detent plate (**Figure 30**) for severe wear or damage.
11. Refer to *Access Door Bearings* in this chapter to clean, inspect and replace bearings.
12. Replace worn or damaged parts as required.



Assembly

Refer to **Figure 1**.

1. Clamp the transmission access door in a vise with soft jaws.
2. Lubricate each shift fork bore with new transmission oil prior to installation.

NOTE

Refer to **Figure 31** when identifying and installing the shift forks.

3. Install shift fork No. 1 (third and fifth gear), with its flat side facing toward the access door, into the mainshaft second gear groove (A, **Figure 32**).
4. Install shift fork No. 2 (first and second gear), with its flat side facing away from the access door, into the countershaft third gear groove (B, **Figure 32**).
5. Install shift fork No. 3 (fourth gear), with its flat side facing away from the access door, into the mainshaft first gear groove (C, **Figure 32**).
6. Align the shift drum, with its neutral indicator pin (B, **Figure 25**) facing up, with the shift forks. Then insert the shift drum (**Figure 21**) through the shift forks and the bearing in the access door.
7. Lubricate the shift fork pins with new transmission oil prior to installation.

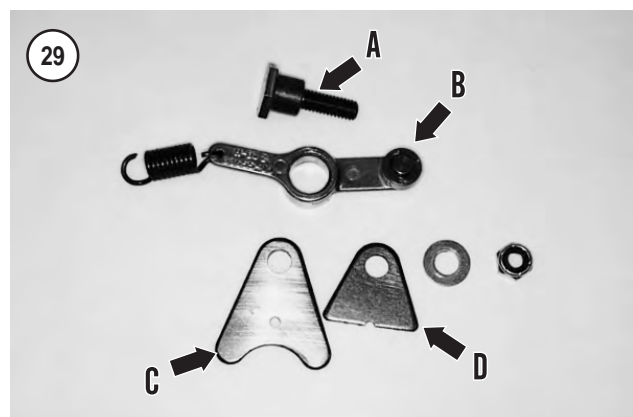

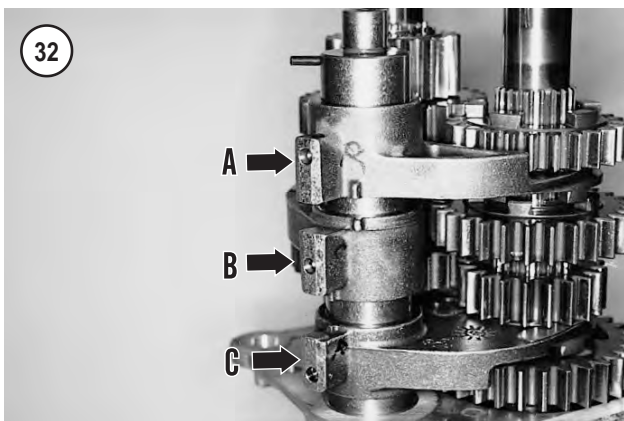
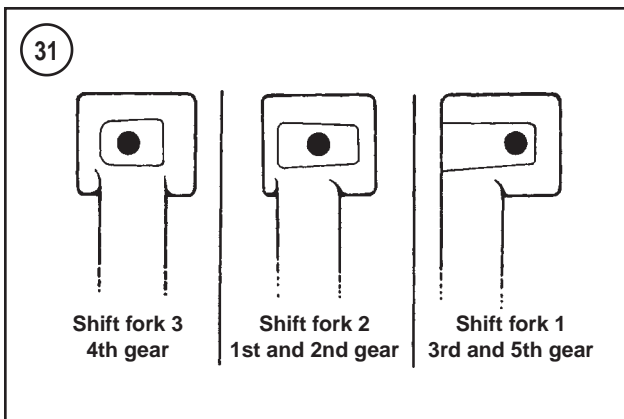
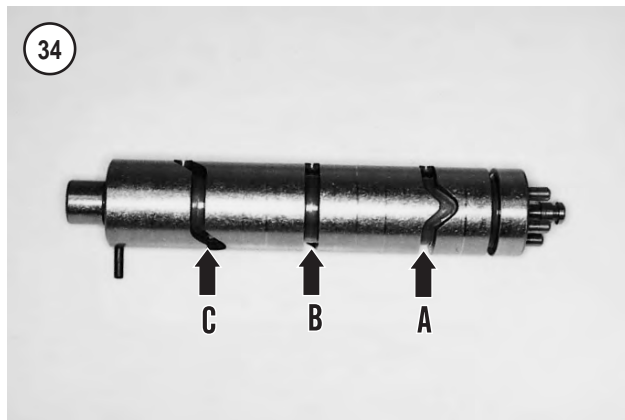

CAUTION
 The cotter pins must be installed through the shift forks as shown in **Figure 33**. Otherwise, the cotter pins may be damaged during transmission operation.

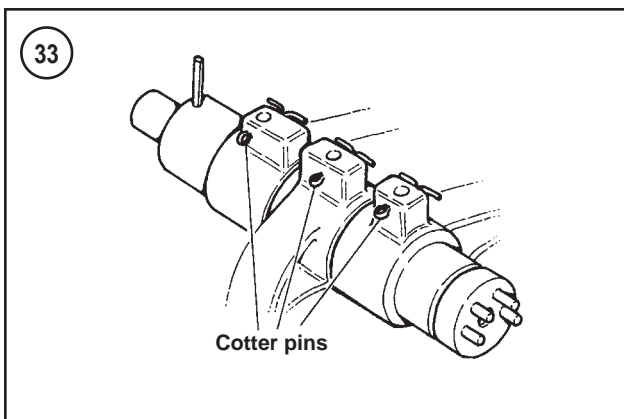

8. Align the lower shift drum groove (A, **Figure 34**) with the pin hole in shift fork No. 3 (fourth gear); refer to C, **Figure 32**. Install the shift fork pin through the shift fork so it drops into the shift drum groove; turn the shift drum while pushing on the pin with a small screwdriver. Then install a new cotter pin.

9. Align the center shift drum groove (B, **Figure 34**) with the pin hole in shift fork No. 2 (first and second gear); refer to B, **Figure 32**. Install the shift fork pin through the shift fork so it drops into the shift drum groove; turn the shift drum while pushing on the pin with a small screwdriver. Then install a new cotter pin.

10. Align the upper shift drum groove (C, **Figure 34**) with the pin hole in shift fork No. 1 (third and fifth gear); refer to A, **Figure 32**. Install the shift fork pin through the shift fork so it drops into the shift drum groove; turn the shift drum while pushing on the pin with a small screwdriver. Then install a new cotter pin.

NOTE
 Refer to **Figure 33** and **Figure 35** for the correct installation of the shift fork cotter pins.

11. Install the shift drum locating plate (**Figure 36**) into the shift drum groove, making sure the hole in the plate fits over the roll pin in the access door (**Figure 37**).
12. Install the reinforcing plate (A, **Figure 38**) on top of the shift drum locating plate, making sure to engage the notch in the reinforcing plate with the roll pin in the access door.
13. Slide the detent screw (A, **Figure 39**) through the detent arm (B, **Figure 39**). Then insert the detent screw through the access door and through the two plates previously installed; see **Figure 38**. Install the washer and nut (B, **Figure 39**). Tighten the detent screw to 156-204 in.-lb. (18-23 N•m).

NOTE

*Do not install the detent plate (6, **Figure 1**) and snap ring (5) at this time. These parts are installed during transmission installation and shift pawl adjustment.*

14. Install the transmission as described in this chapter.

MAINSHAFT AND COUNTERSHAFT

Refer to **Figure 40**.

Disassembly

NOTE

Identify and store all parts as they are disassembled so they will be installed in their same locations.

1. Remove the transmission as described in this chapter.
2. Remove the shift forks and shift drum as described in this chapter.
3. Clamp the transmission in a vise with soft jaws as shown in **Figure 41**. The transmission shafts are identified as follows:
 - a. Countershaft (A, **Figure 41**).
 - b. Mainshaft (B, **Figure 41**).
4. Remove the snap ring (**Figure 42**) positioned next to countershaft fifth gear.
5. Remove the following gears in order:
 - a. Countershaft fifth gear (**Figure 43**).
 - b. Mainshaft second gear (**Figure 44**).
 - c. Countershaft second gear (**Figure 45**).
6. Remove the countershaft second gear split bearing (**Figure 46**).
7. Remove the countershaft thrust washer (A, **Figure 47**).
8. Remove the snap ring (B, **Figure 47**) positioned next to countershaft third gear.
9. Remove countershaft third gear (**Figure 48**).
10. Remove the snap ring (**Figure 49**) and thrust washer located next to mainshaft third gear. See **Figure 50**.
11. Remove the mainshaft third gear (**Figure 51**).



12. Remove the mainshaft third gear split bearing (**Figure 52**).
13. Remove the mainshaft thrust washer (**Figure 53**).
14. Press the countershaft out of its access door bearing as follows:
 - a. Remove the access door from the vise and install the countershaft gear support plate (part No. HD-37404) under countershaft fourth gear as shown in **Figure 54**.
 - b. Support the countershaft gear support plate on some metal blocks in a press so the countershaft can be pressed out without any interference. Center the countershaft under the press ram. See **Figure 55**.
 - c. Place a mandrel on top of the countershaft and press the countershaft out of the access cover. Catch the countershaft assembly (**Figure 56**) so it does not fall onto the floor.
15. Remove the following components from the countershaft:
 - a. Bevel spacer (**Figure 57**).
 - b. Countershaft fourth gear (**Figure 58**).
 - c. Snap ring (A, **Figure 59**) and thrust washer (B) positioned next to first gear.
 - d. Countershaft first gear (C, **Figure 59**).
 - e. Split bearing (A, **Figure 60**).
 - f. Thrust washer (B, **Figure 60**).
 - g. Snap ring (C, **Figure 60**).

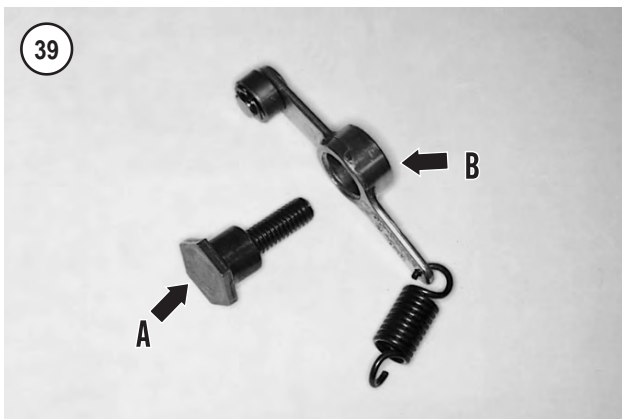

16. Remove the snap ring and mainshaft first gear (Figure 61).

17. Press the mainshaft out of its access door bearing as follows:

- a. Support mainshaft fourth gear in a press as shown in Figure 62. Make sure the mainshaft can be pressed out without any interference. Center the mainshaft under the press ram.
- b. Place a mandrel on top of the mainshaft and press the mainshaft out of the access cover. Catch the mainshaft so that it does not fall to the floor.

18. Remove the following components from the mainshaft:

- a. Spacer (19, Figure 40).
- b. Mainshaft fourth gear (18, Figure 40).
- c. Split bearing (16, Figure 40).
- d. Thrust washer (14, Figure 40).
- e. Snap ring (13, Figure 40).

Inspection

The manufacturer does not provide dimensional or service specifications.

Replace parts that are excessively worn or damaged as described in this section.

1. Clean all components in solvent and dry with compressed air.

NOTE

Defective gears should be replaced. It is a good idea to replace the mating gears as a set.

2. Check each gear tooth for excessive wear, burrs, galling and pitting. Check each gear for missing teeth. Make sure the gear lugs are in good condition.
3. Install each splined gear (Figure 63) on its respective shaft and check for excessive play or binding.
4. Check each sliding gear (Figure 64) for scoring, galling or seizure marks. Spin the gear on its shaft; it should turn freely.
5. Check the groove in each sliding gear (Figure 63) for severe wear or damage. If the groove is worn or damaged, check the mating shift fork for damage. Replace the gear if necessary.
6. Check the bearing surface on each shaft. These surfaces must be smooth. See Figure 65 and Figure 66.
7. Check the shaft splines (Figure 67) for severe wear or damage.
8. Inspect the snap ring grooves (Figure 68) in each shaft. Each groove must have sharp square shoulders. If any are worn or damaged, the shaft(s) must be replaced. See the damaged splines in Figure 69.
9. Check the split bearings (Figure 70) for severe wear or damage.
10. Check the thrust washers for galling, scoring, cracks or other damage. If the washers are not smooth, replace them.
11. Check the countershaft (Figure 65) and mainshaft (Figure 66) for bending, damaged splines or other abnormal wear.

Assembly

Refer to Figure 40.

CAUTION

Replace all snap rings to ensure proper gear alignment and engagement. Do not expand a snap ring more than necessary to slide it over the shaft.

1. Apply a light coat of new transmission oil to all sliding gear and shaft sliding surfaces and split bearings (Figure 70) prior to installing any part.
2. If removed, install the access door bearings as described in this chapter.
3. Press the mainshaft into its bearing as follows:

CAUTION

The bearing driver must press against the inner bearing race or bearing damage results.

- a. Place a bearing driver (A, Figure 71) in a press that matches the mainshaft bearing inner race diameter. Place the bearing inner race on the driver so that the access door inner surface faces up as shown in B, Figure 71.

40

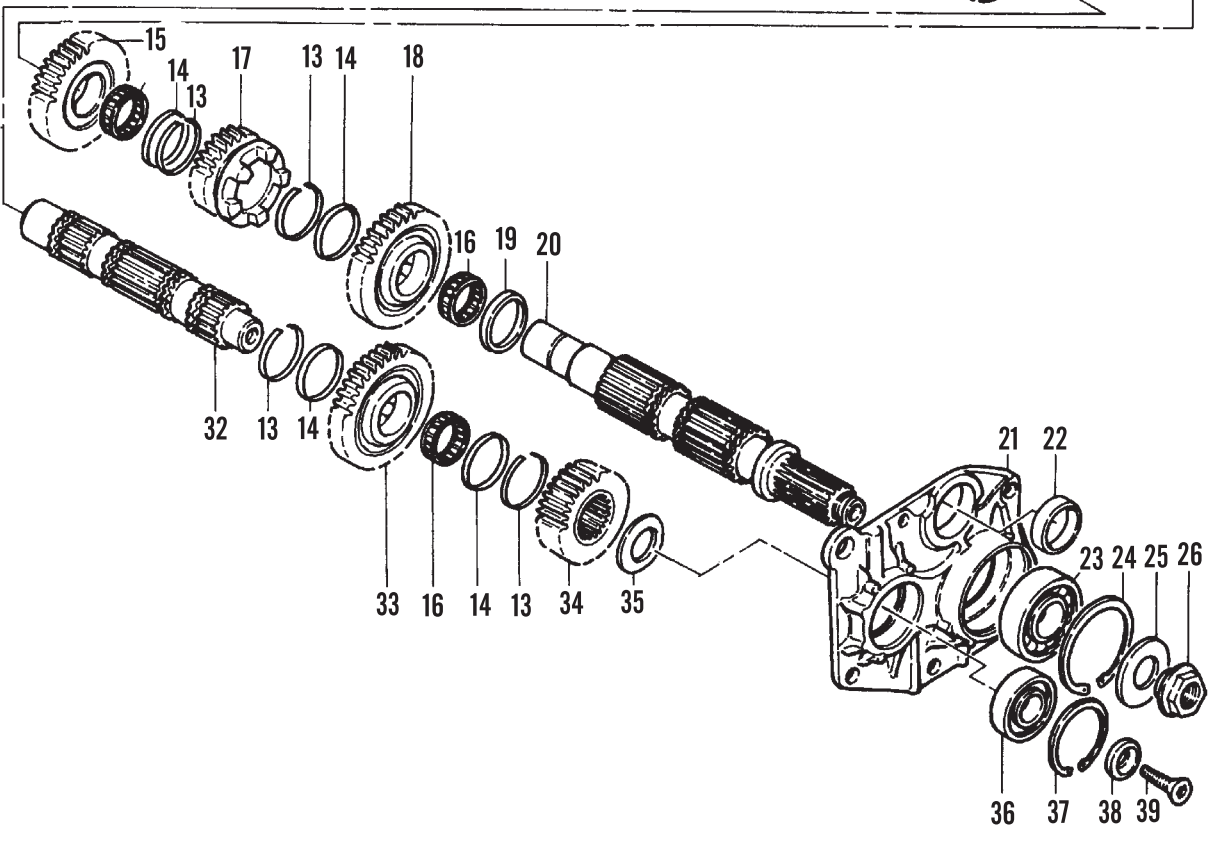
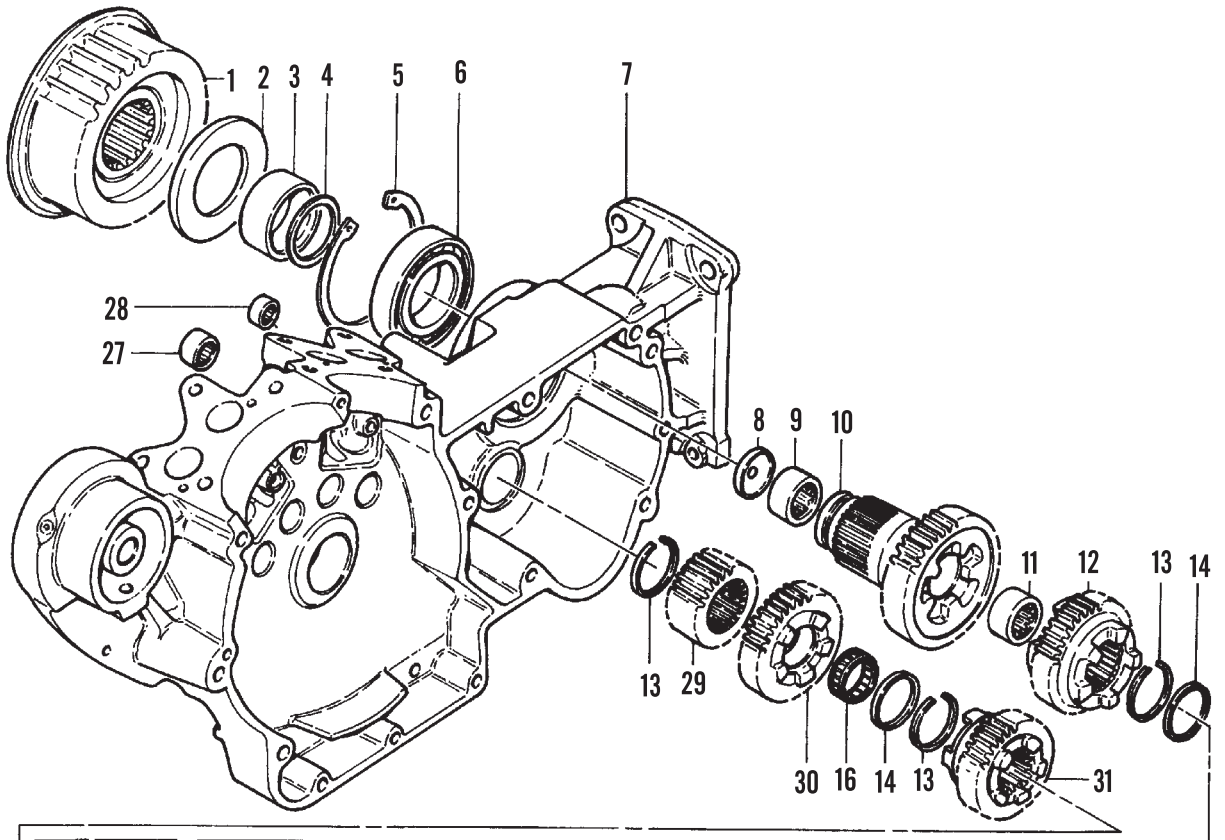

TRANSMISSION

1. Drive sprocket
2. Oil seal
3. Spacer (drive belt)
4. Quad ring
5. Snap ring
6. Bearing
7. Right crankcase half
8. Seal
9. Needle bearing
10. Main drive gear
11. Needle bearing
12. Mainshaft second gear
13. Snap ring
14. Thrust washer
15. Mainshaft third gear
16. Split bearing
17. Mainshaft first gear
18. Mainshaft fourth gear
19. Spacer
20. Mainshaft
21. Access door
22. Bushing
23. Bearing
24. Snap ring
25. Spring washer
26. Mainshaft nut
27. Countershaft needle bearing
28. Shift shaft needle bearing
29. Countershaft fifth gear
30. Countershaft second gear
31. Countershaft third gear
32. Countershaft
33. Countershaft first gear
34. Countershaft fourth gear
35. Beveled washer
36. Bearing
37. Snap ring
38. Retainer collar
39. Screw

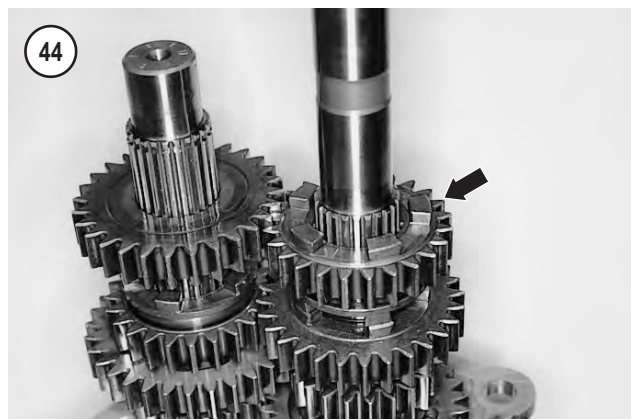
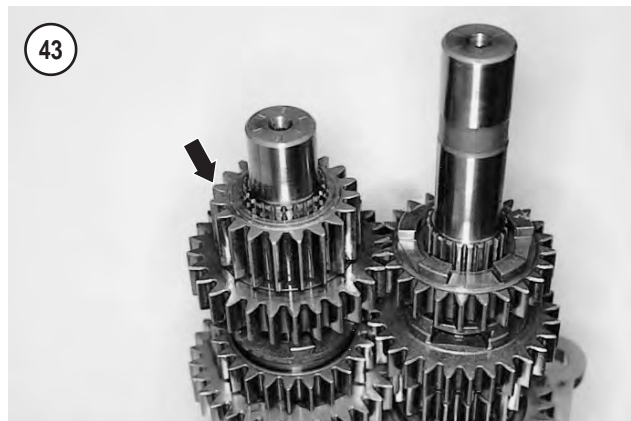
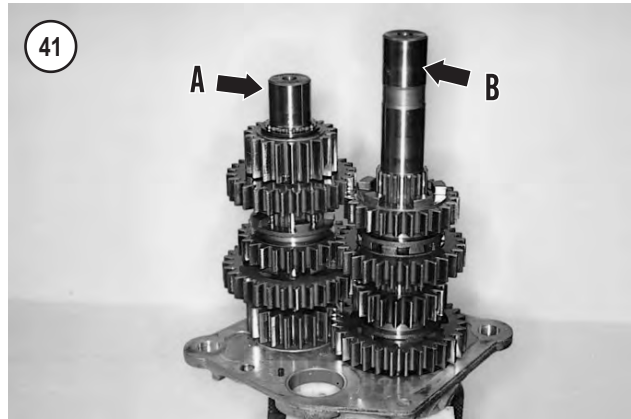

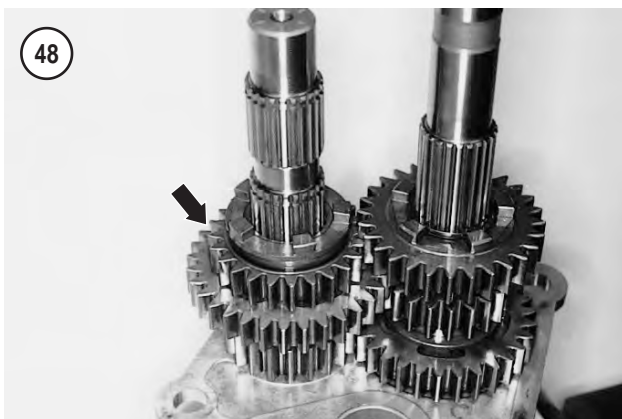
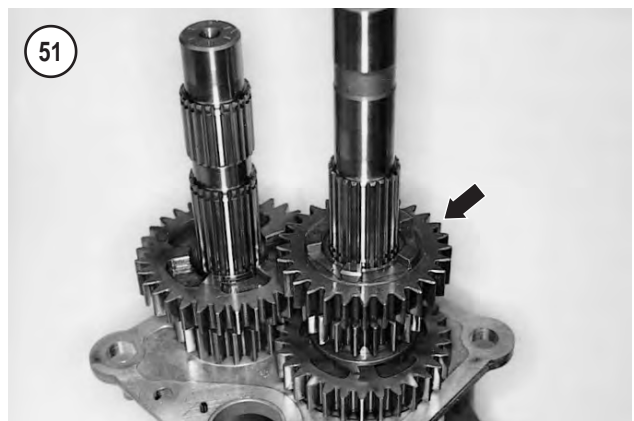
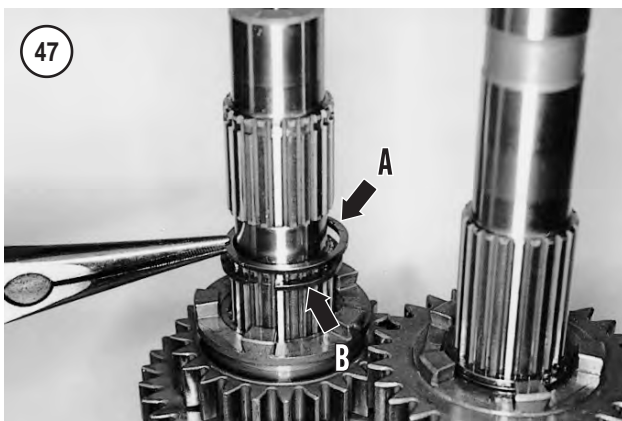
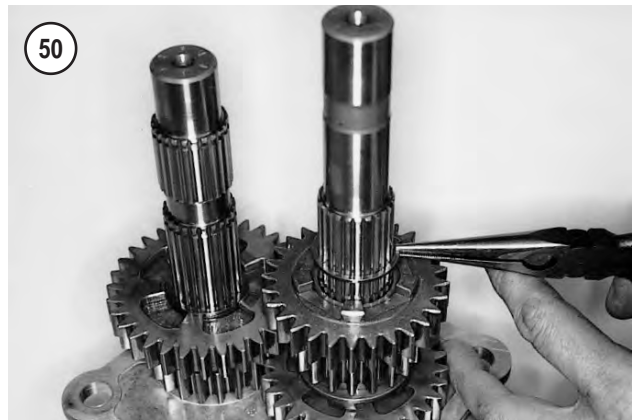
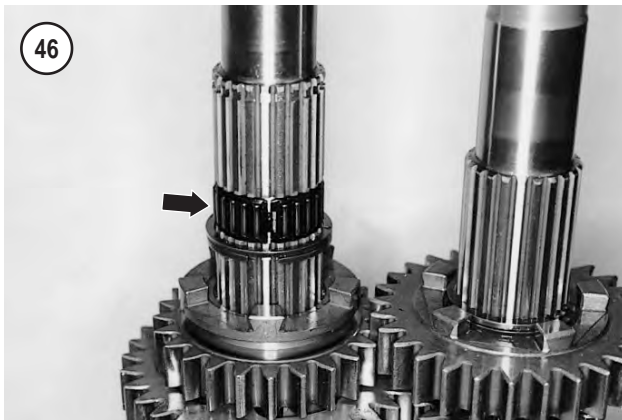
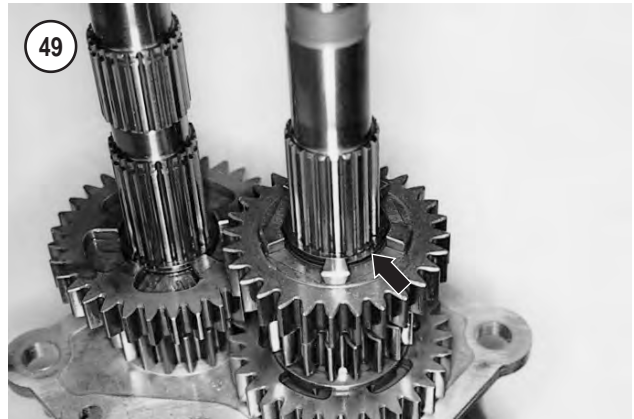
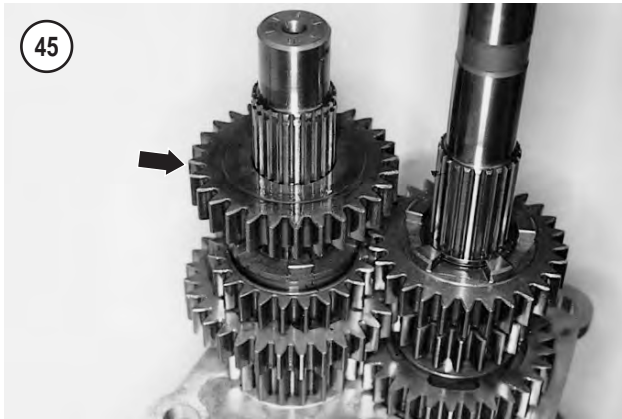

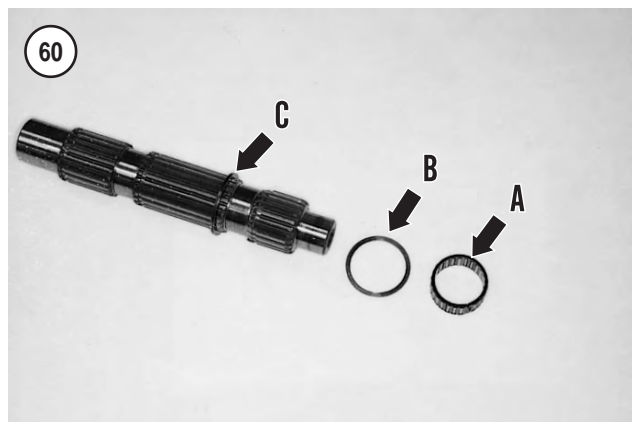
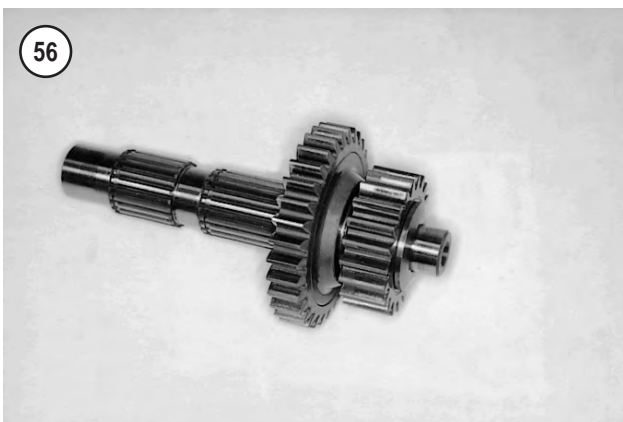
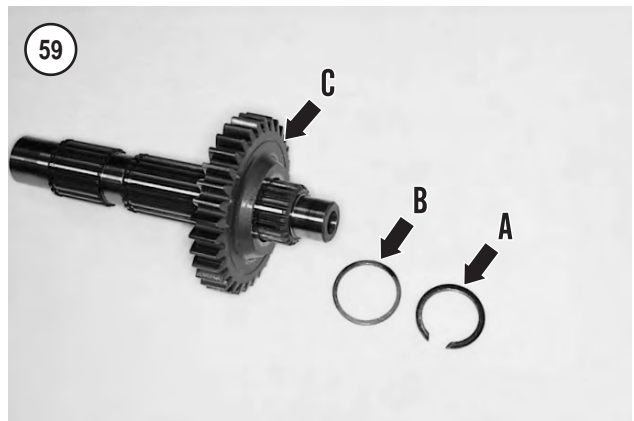
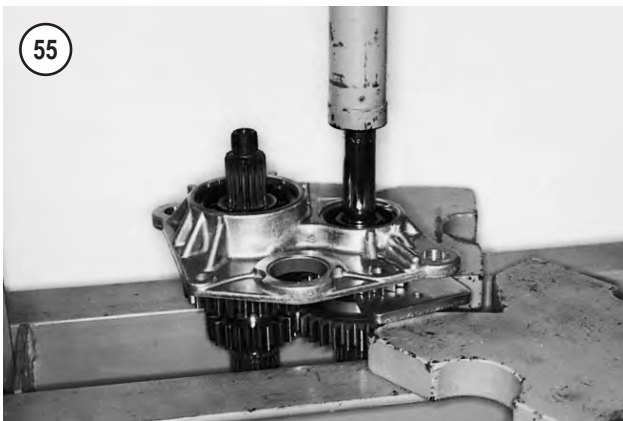
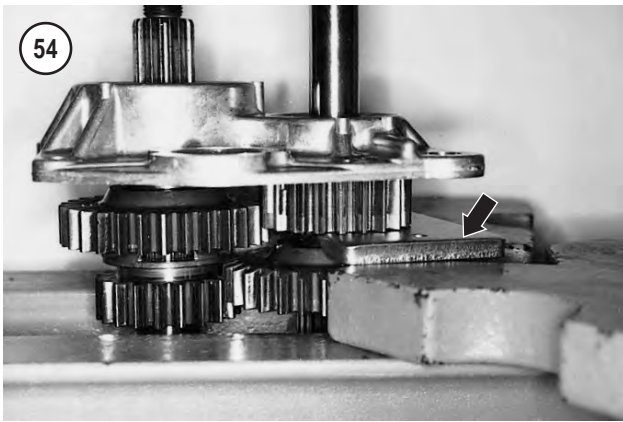
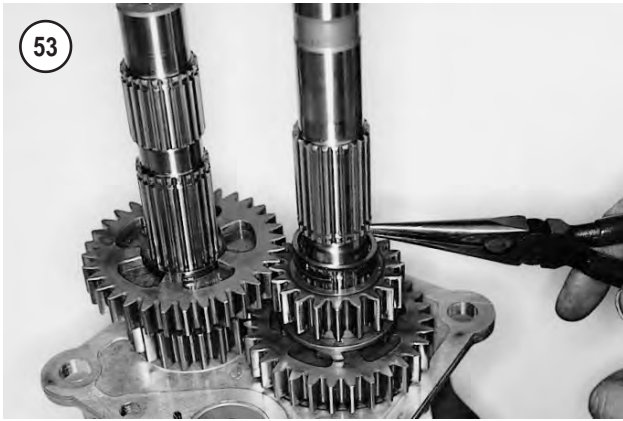

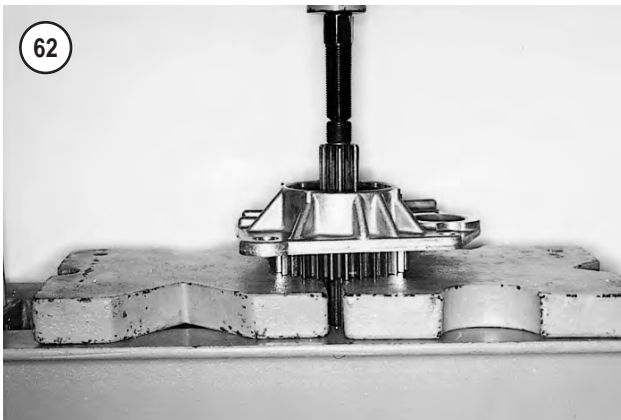
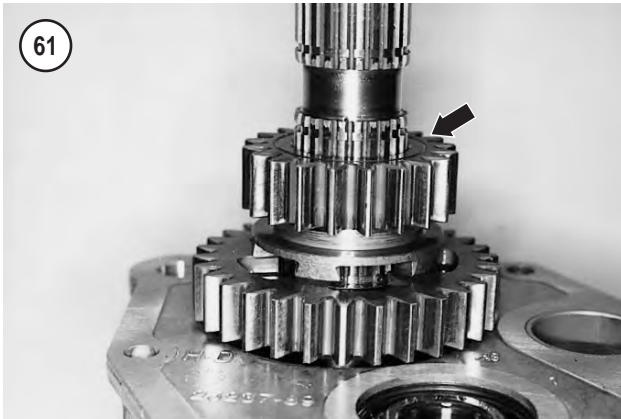

- b. Insert the mainshaft splined end (C, **Figure 71**) through the bearing and center it with the press ram (**Figure 72**).
 - c. Press the mainshaft into the bearing until the mainshaft shoulder bottoms out against the bearing.
 - d. Remove the mainshaft/access door assembly from the press and support it in a vise with soft jaws.
4. Slide the spacer (**Figure 73**) down the mainshaft and seat it against the bearing (A, **Figure 74**).
 5. Install the mainshaft fourth gear split bearing and seat it next to the spacer (B, **Figure 74**)

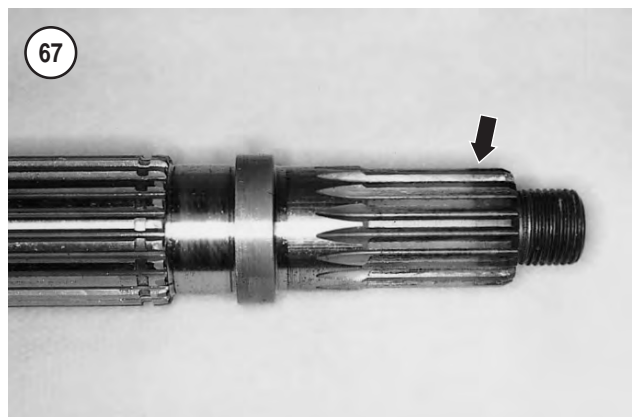

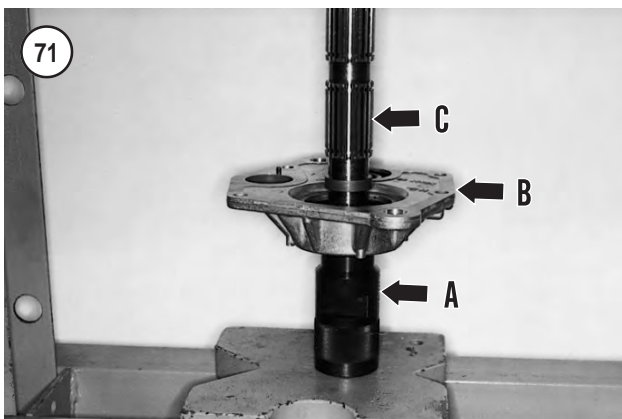
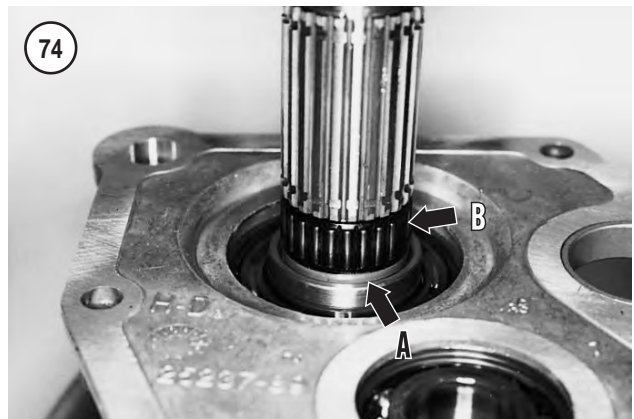
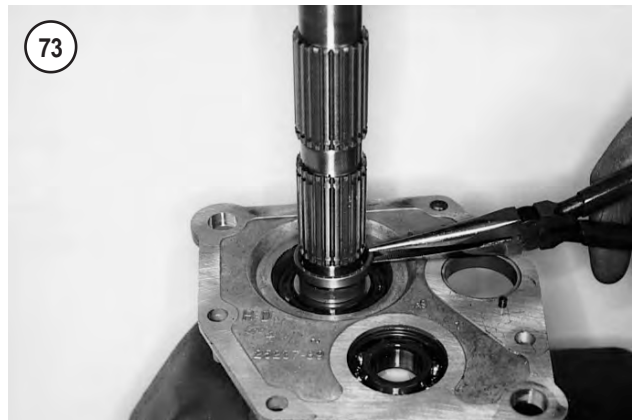
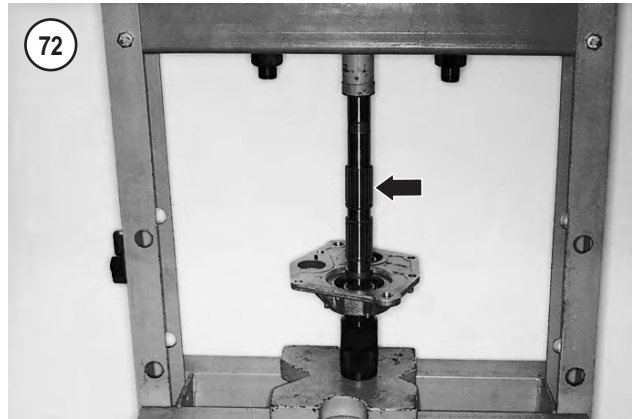
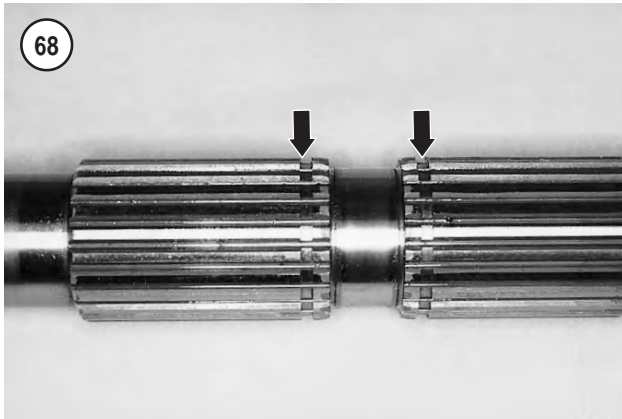

6. Install mainshaft fourth gear with its shoulder (**Figure 75**) facing toward the access door bearing. Slide the gear over the bearing (**Figure 76**).

7. Install the thrust washer (**Figure 77**) and snap ring. Seat the snap ring in the groove next to 4th gear (**Figure 78**). Because of the gear's recess, push the snap ring into its groove with a screwdriver.

8. Install mainshaft first gear (**Figure 79**) so the gear dogs face toward the access door.

9. Install a snap ring into the second countershaft groove on the end of the shaft with the internal threads (**Figure 80**).

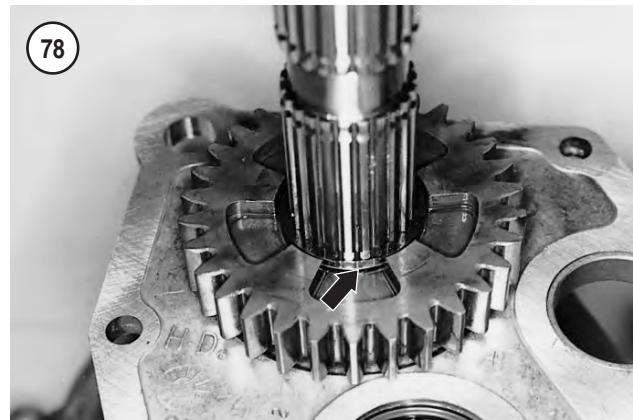
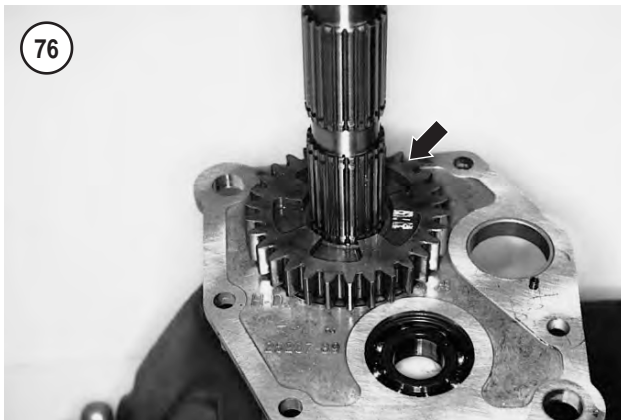
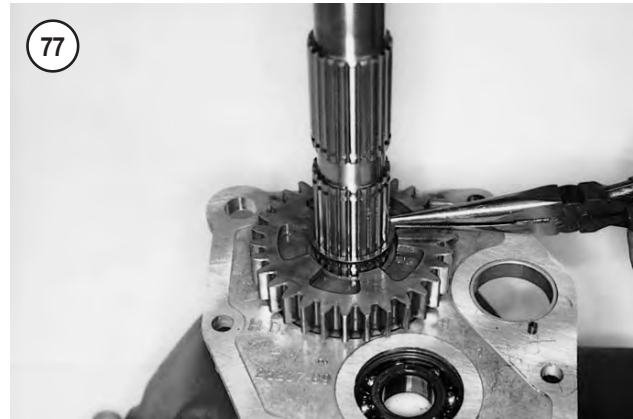

10. Install the thrust washer next to the retaining ring (A, **Figure 81**).

11. Install the split bearing next to the thrust washer (B, **Figure 81**).

12. Install the countershaft first gear so the gear's shoulder faces toward the open snap ring groove. Slide the gear (**Figure 82**) over the bearing.

13. Install the thrust washer (A, **Figure 83**) and seat it next to the gear.

14. Install the snap ring (B, **Figure 83**) into the groove next to the thrust washer. See **Figure 84**.

15. Install countershaft fourth gear (A, **Figure 85**) so the side with the single radial groove faces the thrust washer installed in Step 14.

16. Install the bevel washer (B, **Figure 85**) over the countershaft so its beveled side faces away from the gear. Seat the washer next to fourth gear.

17. Press the countershaft (**Figure 86**) into its access door bearing as follows:

- a. Support the countershaft in a press so that the assembled gear end faces up. Place the bottom of the countershaft on a press block. See A, **Figure 87**.
- b. Place the access door (B, **Figure 87**) countershaft bearing over the countershaft while at the same time meshing the countershaft and mainshaft gears. Hold both gear shafts straight up.

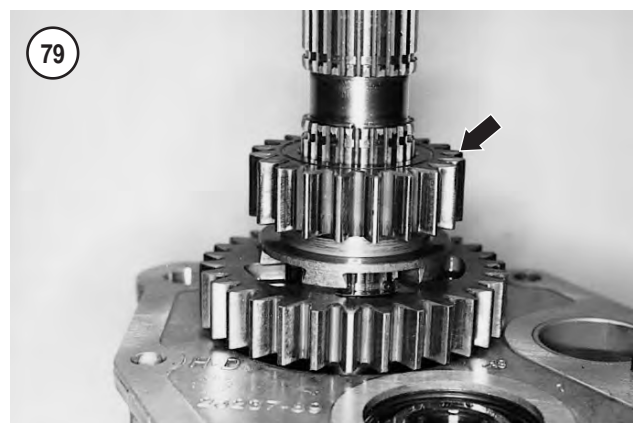

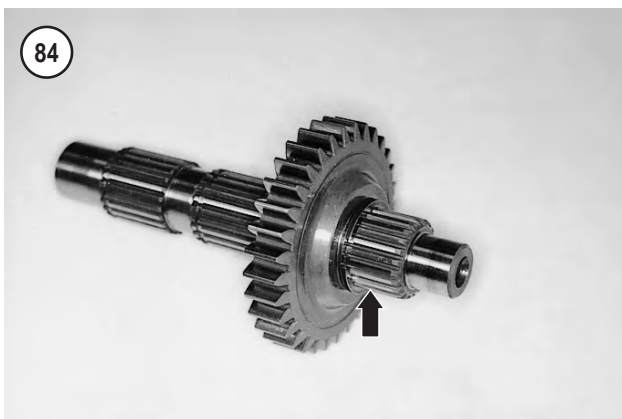
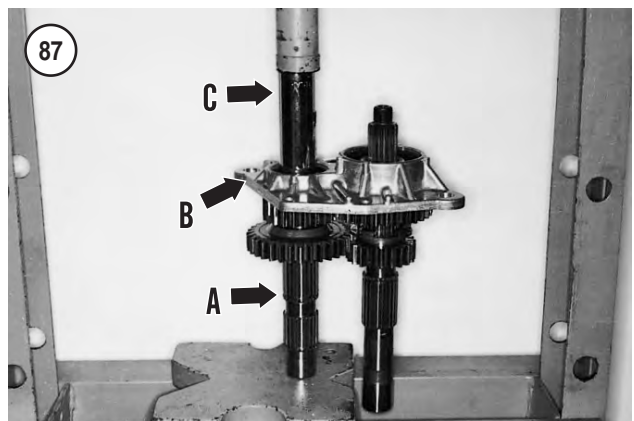
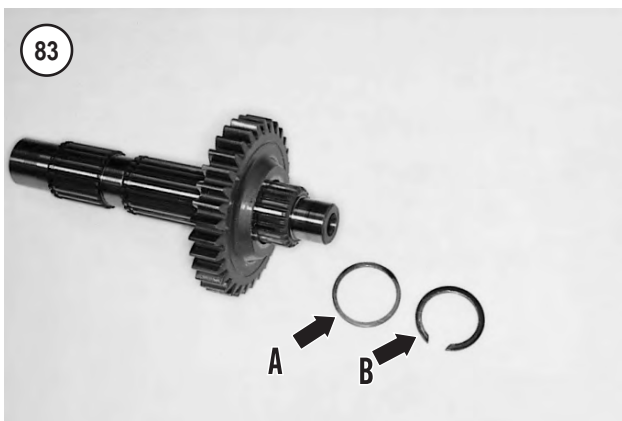
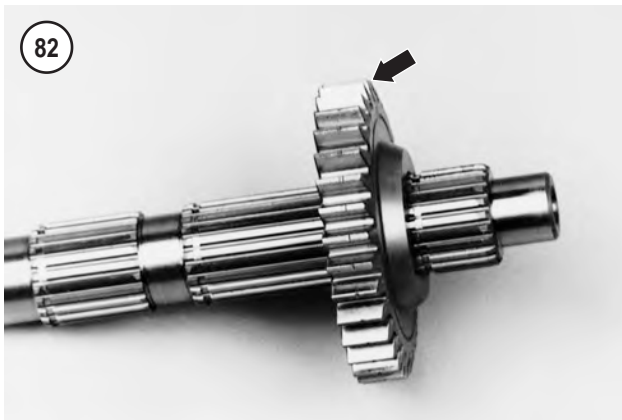
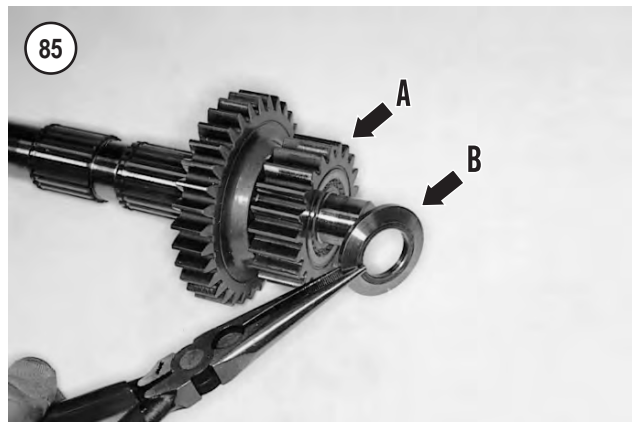

CAUTION

The bearing driver must press against the inner bearing race or bearing damage will result.

- c. Place a bearing driver (C, **Figure 87**) over the inner countershaft bearing race. Center the bearing driver underneath the press ram.
- d. Bring the press ram into position over the countershaft, checking that both shafts are straight up and that both gear sets are properly meshed, then press the bearing onto the countershaft until the beveled spacers bottom out against the bearing.

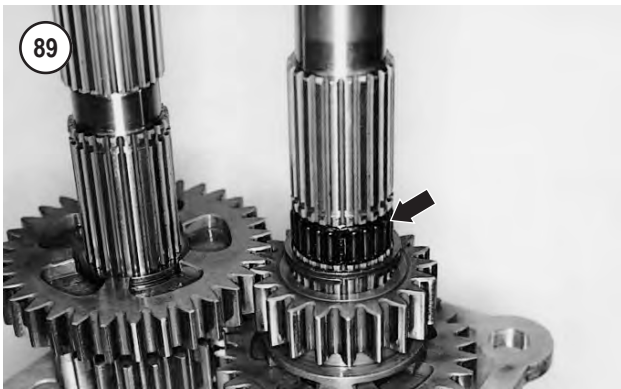
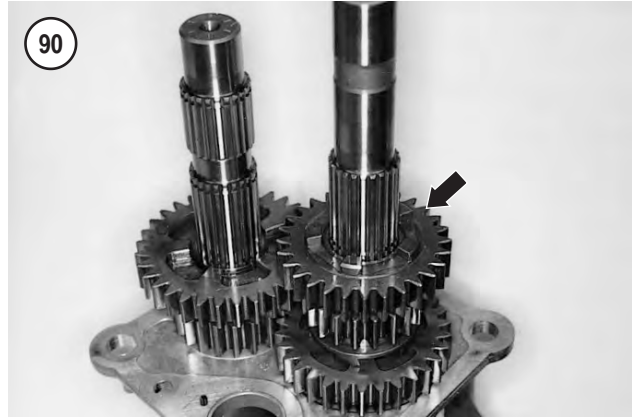
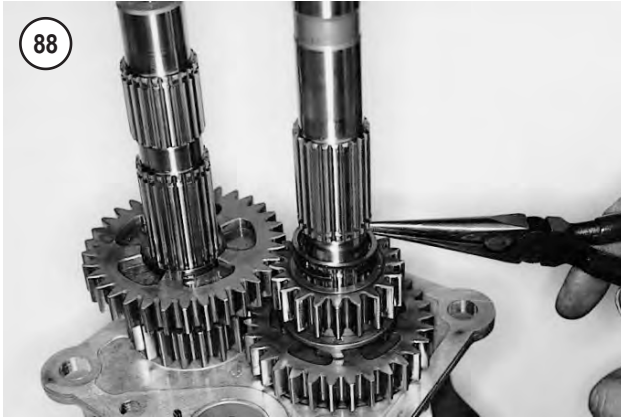

- e. Release the press ram and check countershaft fourth gear. When properly installed, countershaft fourth gear should have no end play.

18. Secure the access door in a vise with soft jaws.
19. Install the snap ring and thrust washer (**Figure 88**) onto the mainshaft. Seat the snap ring in the groove next to mainshaft first gear.
20. Install the mainshaft third gear split bearing (**Figure 89**) next to the thrust washer.
21. Install mainshaft third gear (**Figure 90**) over the split bearing so that the gear dogs face up.
22. Install the thrust washer and snap ring. Seat the snap ring (**Figure 91**) in the groove next to mainshaft third gear.
23. Install countershaft third gear (**Figure 92**) so its gear dogs face away from the access cover.
24. Install the countershaft snap ring (A, **Figure 93**) and thrust washer (B). Seat the snap ring in the groove next to the countershaft third gear.
25. Install the countershaft split bearing (**Figure 94**) next to countershaft third gear.
26. Install countershaft second gear (**Figure 95**) over the split bearing. Install the gear so its gear dogs face the access cover.
27. Install mainshaft second gear (**Figure 96**) so that the side with the shift fork groove is toward the access cover.
28. Install countershaft fifth gear (**Figure 97**).

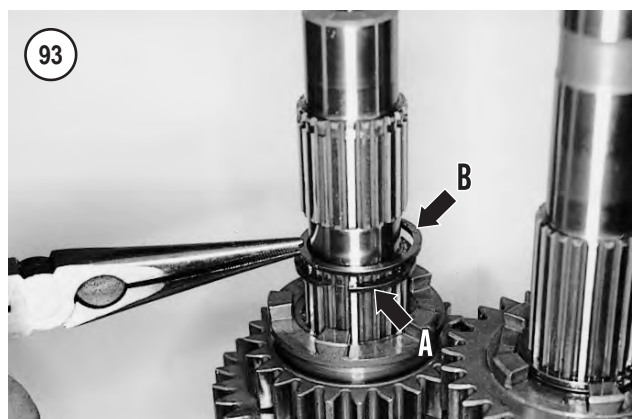
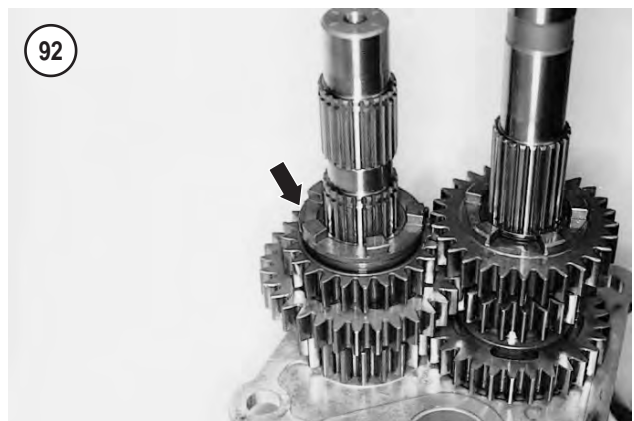

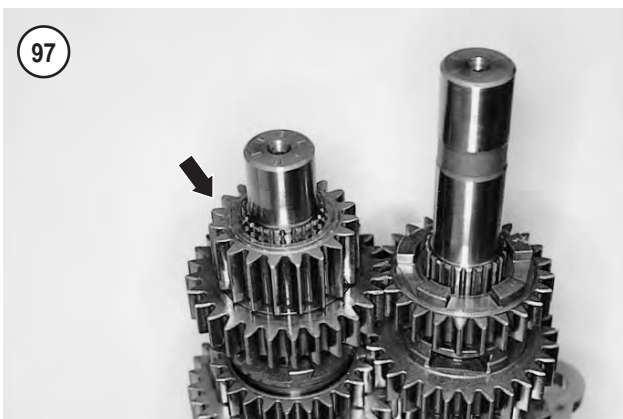
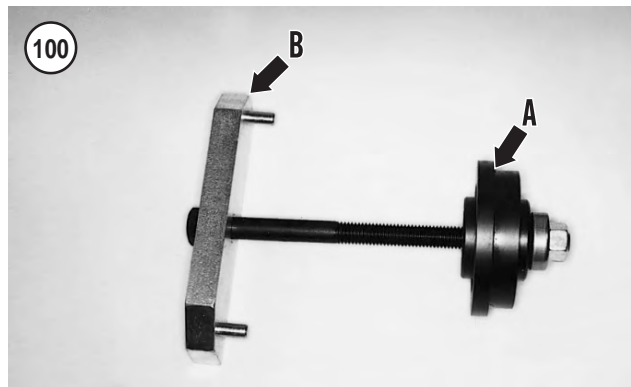
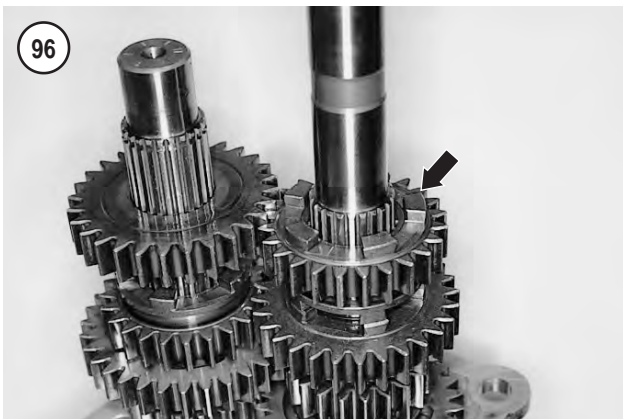
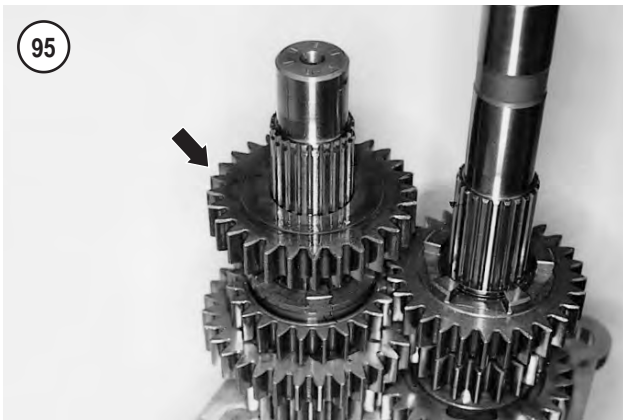
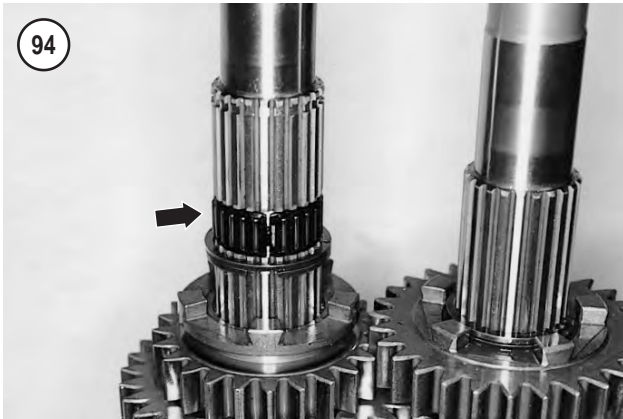

29. Install the snap ring into the groove next to countershaft fifth gear (**Figure 98**).

30. Install the shift forks and shift drum as described in this chapter.

MAIN DRIVE GEAR

Two tools are required to remove and install the main drive gear located in the right crankcase half. Removing the main drive gear without these tools, may cause crankcase and/or main drive gear damage.

1. Main drive gear remover and installer (part No. HD-35316A). See **Figure 99** and A, **Figure 100**.
2. Cross plate (part No. HD35316-91). See B, **Figure 100**.

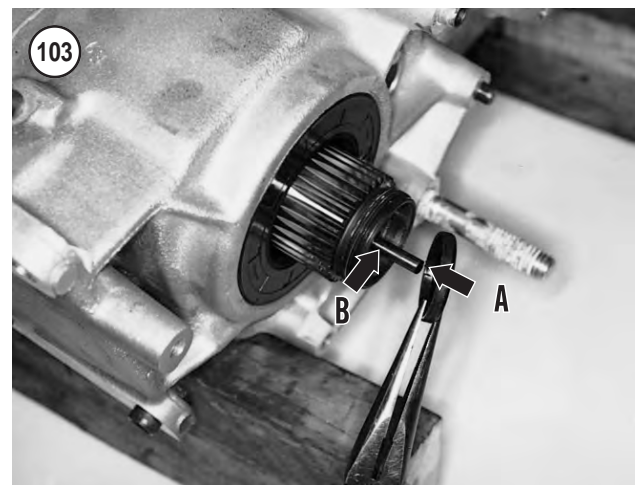
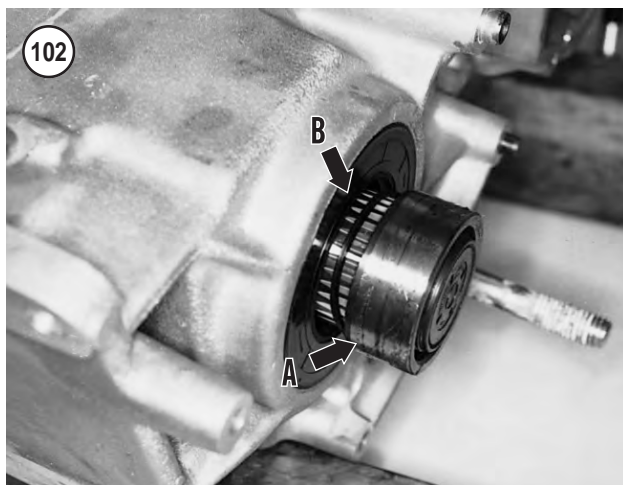
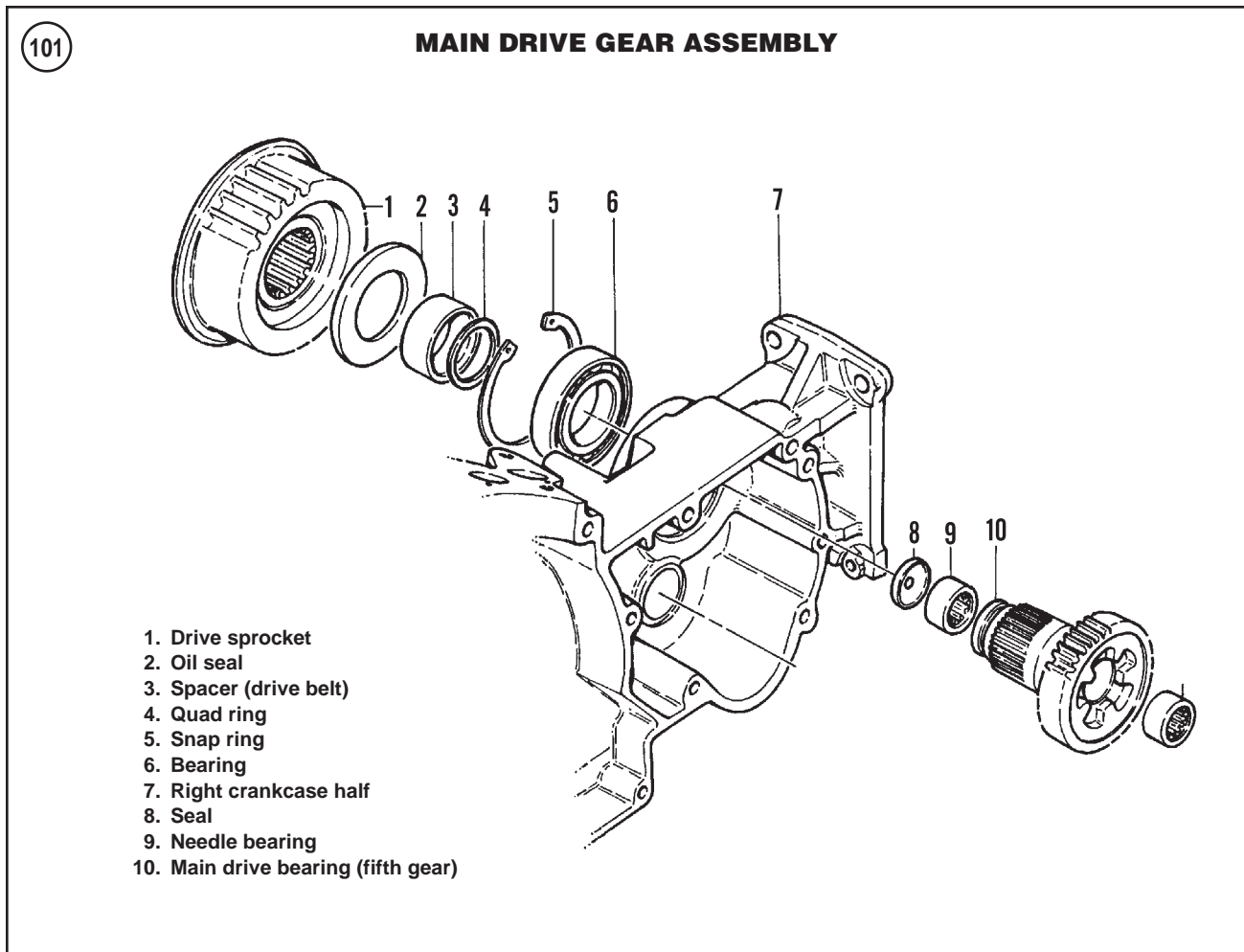

Refer to **Figure 101**.

Removal

1. Remove the transmission as described in this chapter.
2. Remove the spacer ring (A, **Figure 102**) and quad ring (B) from the main drive gear.

3. Tap out the seal (A, **Figure 103**) that is mounted in the end of the main drive gear. Use a drift inserted through the main drive gear as shown in B, **Figure 103**. Discard the seal.

4. Assemble the main drive gear remover and installer and the cross plate as shown in **Figure 104**. Refer to **Figure 105** and **Figure 106**.

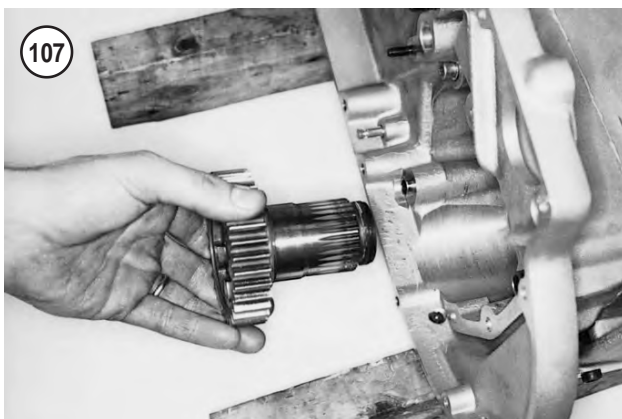
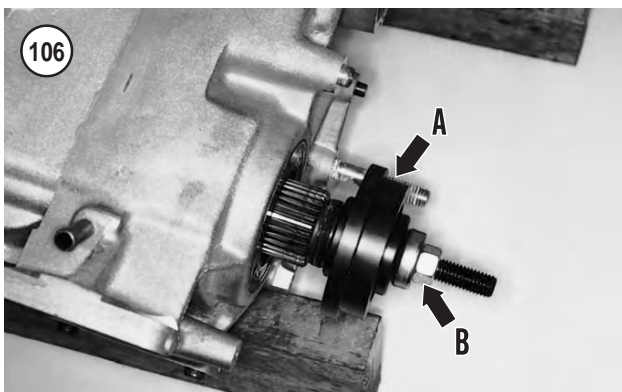
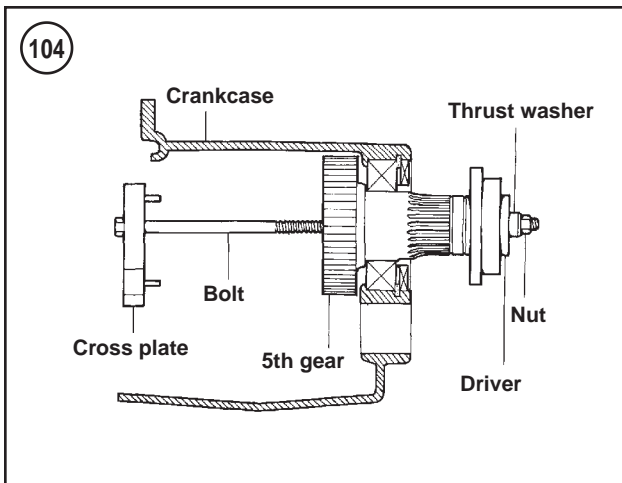

CAUTION
Whenever the main drive gear is removed, the main drive gear bearing must be replaced.

NOTE
Insert the two cross plate pins into the pin holes in the transmission housing. This will center the cross plate over the main drive gear.

5. Tighten the puller nut (B, **Figure 106**) to push the main drive gear from the main drive gear bearing. Remove the nut and puller bolt, and then remove the main drive gear (**Figure 107**) from the transmission portion of the engine crankcase. Disassemble and remove the puller and cross plate assembly. Discard the bearing
6. Pry the main drive gear oil seal (2, **Figure 101**) out of the right crankcase half.
7. Replace the main drive gear bearing as described in *Right Transmission Case Bearings* in this chapter.

Inspection

1. Clean the main drive gear in solvent and dry with compressed air.
2. Check each gear tooth (**Figure 108**) for excessive wear, burrs, galling and pitting. Check for missing gear teeth.
3. Check the gear splines for severe wear, galling or other damage.
4. Inspect the two main drive gear needle bearings (**Figure 109**) for severe wear or damage. Insert the mainshaft into the main drive gear to check bearing wear. If necessary, replace the bearings as described in this section.

Main Drive Gear Needle Bearing Replacement

Both mainshaft drive gear needle bearings (9, **Figure 101**) must be installed to a specific depth (**Figure 110**). Bearing installation can be aided with the inner/outer main drive gear needle bearing installation tool (part No. HD-37842 for 1991-1994 models and part No. HD-37842A for 1995-2003

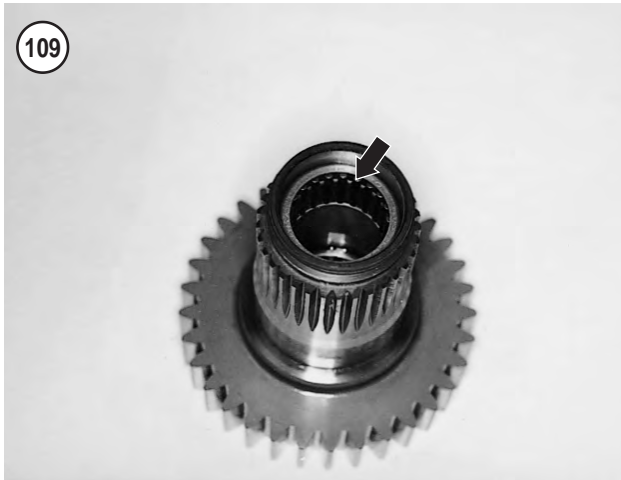

models). This tool installs the bearing to the specified depth. If not using the tool, it is necessary to measure bearing depth when installing the new bearings

Always replace both main drive gear needle bearings at the same time.

CAUTION

Do not install a main drive gear needle bearing that has been removed. Removal damages the bearings.

1. Support the main drive gear in a press and press out both needle bearings.
2. Clean the bearing bore in solvent and dry thoroughly.

NOTE

Install both needle bearings with their manufacturer's name and size code facing out.

3A. The inner/outer main drive gear needle bearing installation tool is stamped with two sets of numbers. The side stamped 0.080 is for pressing in the inner end bearing and is the same for all years. The side stamped 0.285 (1991-1994 models) or 0.315 (1995-2003 models) is for pressing the outer end bearing. **Figure 110** identifies the main drive gear inner and outer ends.

- a. Install the main drive gear in a press with the outer end facing up. Align the new bearing with the main drive gear and install the installation tool. Be sure the side stamped 0.285 (1991-1994 models) or 0.315 (1995-2003 models) is inserted into the bearing. Press the bearing until the tool bottoms.
- b. Turn the main drive gear over so that the inner end faces up. Align the new bearing with the main drive gear and install the installation tool with the side marked 0.080 inserted into the bearing. Press the bearing until the tool bottoms.

3B. If bearing installation tools are not available, perform the following. **Figure 110** identifies the main drive gear inner and outer ends.

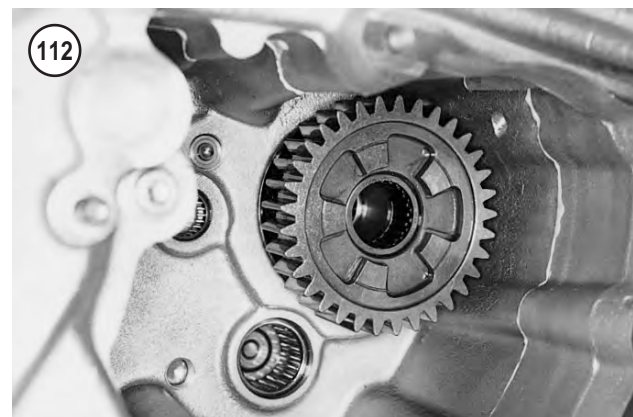
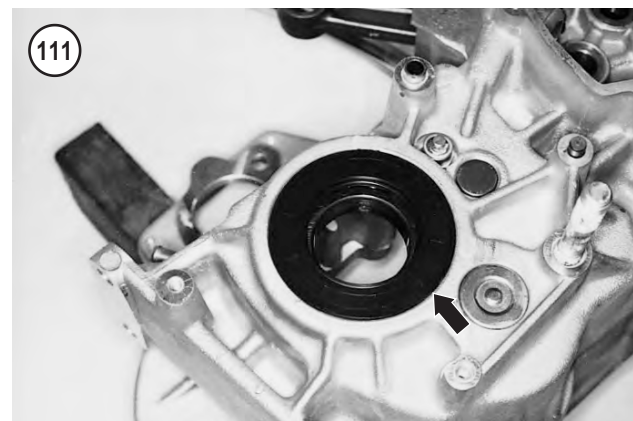
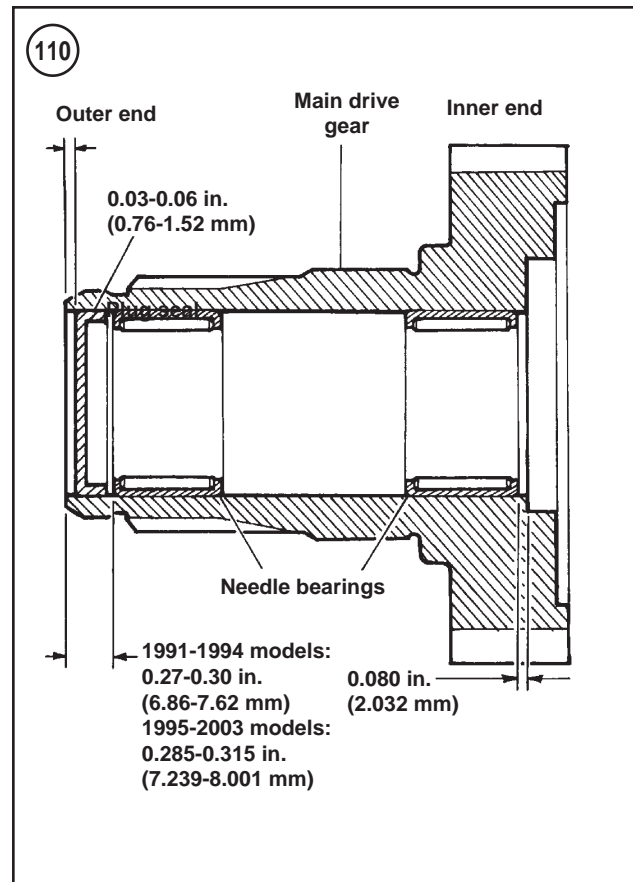

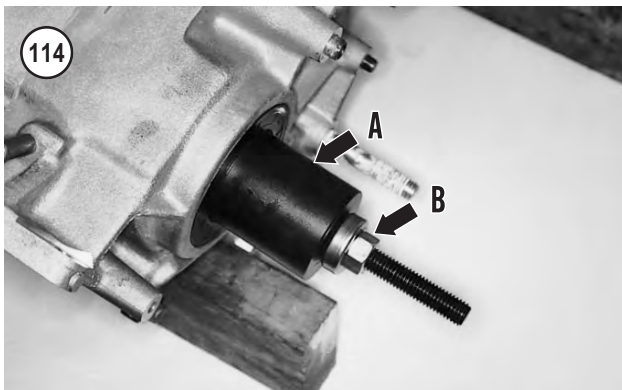

- a. Using a suitable mandrel, press in the outer end bearing to the depth indicated in **Figure 110**.
- b. Using a suitable mandrel, press in the inner end bearing to a depth of 0.080 in. (2.032 mm). See **Figure 110**.

Main Drive Gear Installation

1. Replace the main drive gear bearing (6, **Figure 101**) as described in *Right Transmission Case Bearings* in this chapter.
2. Coat the oil seal lips with transmission oil prior to installation.
3. Slide the oil seal (2, **Figure 101**), with its lips facing toward the crankcase, over the spacer. Tap the oil seal (**Figure 111**) into the crankcase until its outer surface is flush with or slightly below (0.030 in. [0.76 mm] maximum) the oil seal bore inside surface.
4. Insert the main drive gear (**Figure 107**) into the main drive gear bearing in the transmission portion of the engine crankcase as far as it will go (**Figure 112**). Then hold it in place and assemble the main drive gear remover and installer tool as shown in **Figure 113** and A, **Figure 114**.

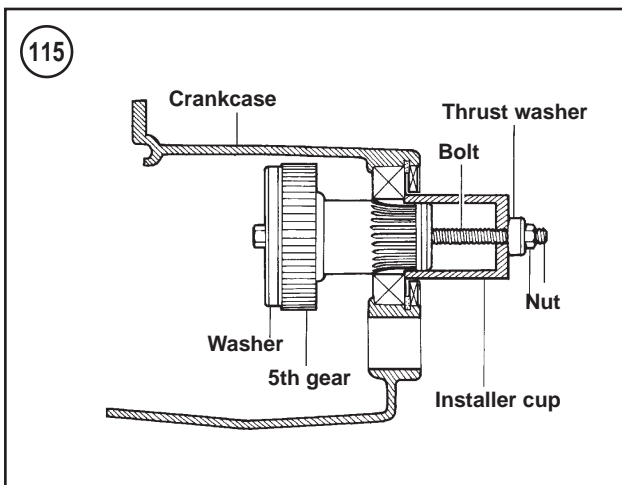

CAUTION

*Note how the installer cup, shown in **Figure 115**, supports the main drive gear bearing inner race. If using a different tool setup, make sure the inner bearing race is supported in the same way. Otherwise, the bearing will be damaged when the main drive gear is pressed into place.*



5. Tighten the puller nut (B, **Figure 114**) to pull the main drive gear through the bearing. Continue until the gear shoulder bottoms against the inner bearing race.
6. Remove the installer tool.
7. Install a new seal (**Figure 116**) into the end of the main drive gear until its outer surface is 0.03-0.06 in. (0.76-1.52 mm) below the bearing bore inside surface as indicated in **Figure 110**.
8. Install a new quad ring (A, **Figure 117**) over the threaded portion of fifth gear and position it next to the gear taper.

9. Slide the spacer (B, **Figure 117**), with its chamfered end facing the quad ring, over fifth gear and seat it against the bearing. See **Figure 118**.
10. Install the transmission as described in this chapter.

ACCESS DOOR BEARINGS

The access door is equipped with the following:

1. Mainshaft bearing (A, **Figure 119**).
2. Countershaft bearing (B, **Figure 119**).
3. Shift drum bushing (C, **Figure 119**).

Mainshaft/Countershaft Bearings Inspection

WARNING

Do not spin the bearings with compressed air. Compressed air will spin the bearings at speeds in excess of their designed capacity. This may cause the bearing to fly apart, which may cause eye damage or other injuries.

1. Clean both bearings in kerosene. Hold the inner bearing race with your fingers and dry the bearing with compressed air.
2. Turn the inner bearing race slowly. The bearing should turn smoothly with no roughness, binding or excessive play. If these conditions are noted, reclean and dry the bearing. If these conditions still persist, replace the bearing as described in this section.
3. If the bearing does not turn smoothly, check for damage. Also check the bearing fit in the bearing bore; both bearings must be a tight fit. If the bearing is a loose fit, check the access door for cracks or other damage.
4. Replace the bearings, if necessary, as described in this section.
5. If the bearings can be reused, lubricate them thoroughly with new transmission oil, then place the access door in a plastic bag and seal it until transmission reassembly.

Shift Drum Bushing Inspection

1. Clean the bushing (C, **Figure 119**) with solvent or kerosene. Dry with compressed air.
2. Inspect the bushing for scoring, overheating, galling or excessive wear.
3. Replace the bushing, if necessary, as described in this section.

Mainshaft/Countershaft Bearing Replacement

This procedure can be used to replace both bearings.

1. Remove the bearing circlip.
2. Support the access door, with its inside surface facing up, in a press.

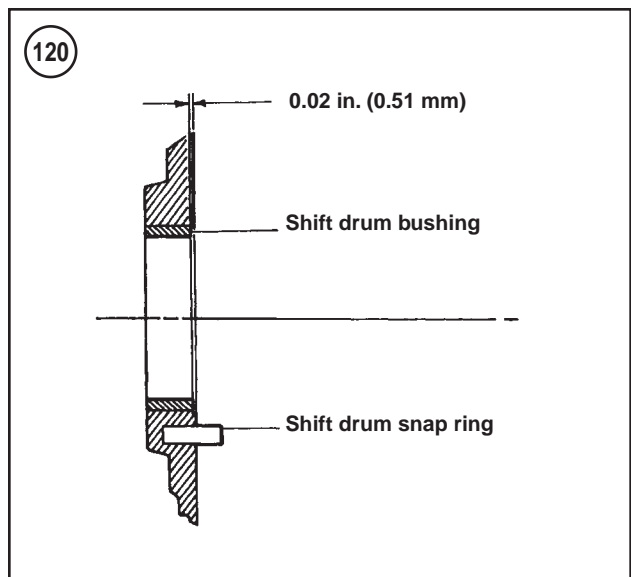
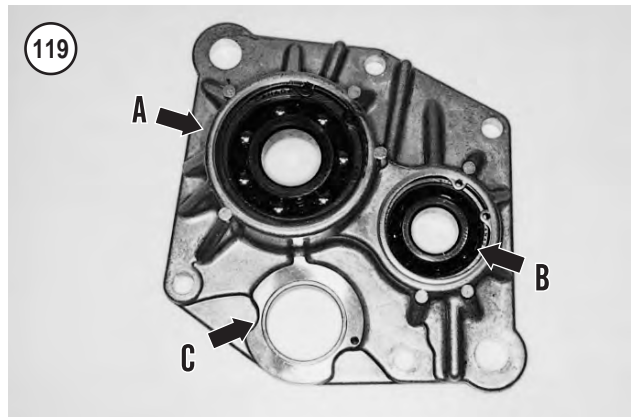

CAUTION

Make sure the access door is positioned so that it is not resting on the shift drum retaining pin. Otherwise, the access door will be damaged when pressure is applied to it.

3. Using a suitable mandrel or bearing driver, press the bearing out of the access door.



8. Install a new circlip, with the beveled side facing away from the bearing, into the access door groove. Make sure the circlip is fully seated in the groove.
9. Repeat for the opposite bearing.

Shift Drum Bushing Replacement

1. Support the access door in a press and press out the bushing from either side.
2. Clean the bushing bore in kerosene and dry with compressed air.
3. Support the access door, with its outside surface facing down, in a press.
4. Press in the bushing until its outer surface is flush with or 0.02 in. (0.51 mm) below the bushing bore inside surface as shown in **Figure 120**.

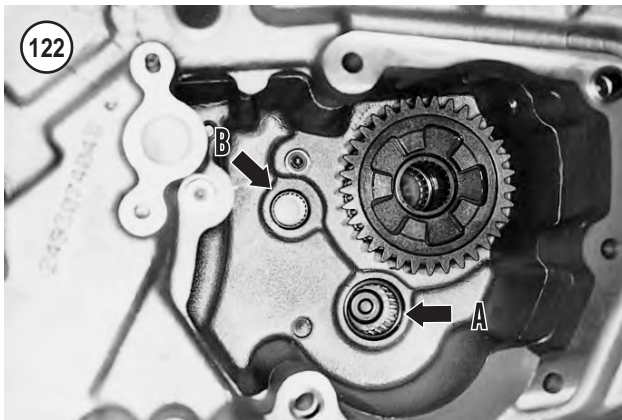

RIGHT TRANSMISSION CASE BEARINGS

The right transmission case is equipped with the following bearings:

1. Main drive gear bearing (A, **Figure 121**).
2. Countershaft needle bearing (A, **Figure 122**).
3. Shift drum needle bearing (B, **Figure 122**).

Each of these bearings can be replaced with the engine crankcase assembled and installed in the frame.

Main Drive Gear Bearing Inspection

Because the main drive gear bearing (A, **Figure 121**) is damaged when the main drive gear is removed, do not attempt to reuse the bearing. Replace the bearing as described in this section.

Countershaft and Shift Drum Needle Bearings Inspection

1. Clean both needle bearings (A and B, **Figure 122**) in kerosene and dry with compressed air.
2. Check the needle bearings for worn, loose or damaged rollers. Check the roller cage and outer shell for damage.
3. Check each bearing for a loose fit in its bore. If the bearing is a loose fit, check the access door for cracks or other damage.
4. Replace the bearings, if necessary, as described in this section.
5. If the bearings can be reused, lubricate them thoroughly with new transmission oil.

Main Drive Gear Bearing Replacement

Refer to **Figure 101**.

1. Pry the main drive gear bearing oil seal (**Figure 123**) out of the crankcase. Pad the screwdriver to avoid damaging the crankcase.



4. Clean the bearing bore and dry with compressed air.
5. Check the circlip groove for severe wear, cracks or other damage. If the groove is damaged, replace the access door.
6. Support the access door, with its outside surface facing up, in a press.

NOTE

Install both bearings with the manufacturer's name and size code facing out.

7. Place a bearing driver on the outer bearing race and press the bearing into the access cover until the bearing bottoms out.

2. Remove the circlip (B, **Figure 121**) from the crankcase groove. This circlip is located behind the main drive gear oil seal.
3. Drive the main drive gear bearing out of the crankcase, working from inside the transmission housing, with a suitable bearing driver. Discard the bearing.
4. Clean the bearing bore and dry with compressed air. Check the bore for nicks or burrs. Check the circlip groove for damage.

NOTE

*The main drive gear remover and installer and cross plate tool, used to remove the main drive gear, are used to install the new bearing. Refer to **Main Drive Gear** for further information on these tools.*

NOTE

Install the bearings with the manufacturer's name and size code facing out.

5. Install the new bearing onto the main drive gear remover and installer and cross plate tools as shown in **Figure 124**.

NOTE

*Insert the two cross plate pins into the pin holes in the transmission housing (**Figure 125**). This will center the cross plate with the main drive gear bearing.*

6. Tighten the puller nut to pull the bearing into the crankcase. Continue until the bearing bottoms out against the bearing bore surface.
7. Disassemble and remove the puller tool assembly.
8. Install the circlip, with its beveled side facing into the crankcase groove. Make sure the circlip is fully seated in the groove.

NOTE

*The main drive gear bearing oil seal is installed during the transmission installation procedure. Refer to **Transmission** in this chapter.*

9. Lubricate the bearing with new transmission fluid.

Countershaft Needle Bearing Replacement

1. Drive the countershaft needle bearing (A, **Figure 122**) out of the crankcase, working from inside the transmission housing, with a suitable bearing driver. Discard the bearing.
2. Clean the bearing bore and dry with compressed air. Check the bearing bore for nicks or burrs.
3. Align the new bearing, with its closed side facing out, with the crankcase bearing bore.
4. Drive in the new bearing until its outer surface is flush with or 0.030 in. (0.76 mm) below the bushing bore inside surface.

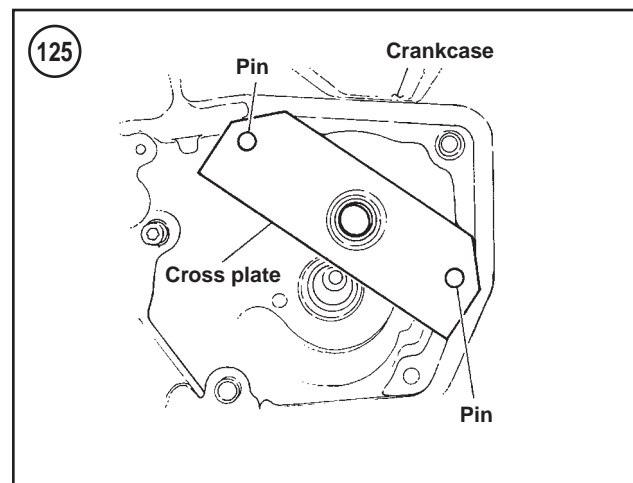
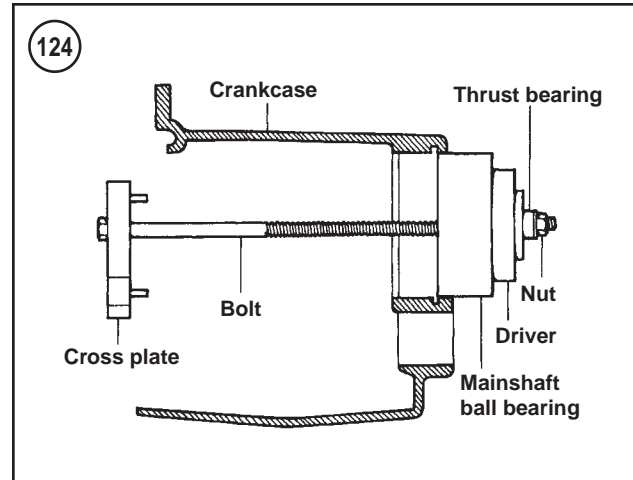

5. Lubricate the bearing with new transmission fluid.

Shift Drum Needle Bearing Replacement

1. Drive the shift drum needle bearing (B, **Figure 122**) out of the crankcase, working from inside the transmission housing, with a suitable bearing driver. Discard the bearing.
2. Clean the bearing bore and dry with compressed air. Check the bearing bore for nicks or burrs.
3. Align the new bearing, with its closed side facing out, with the crankcase bearing bore.
4. Drive in the new bearing until its outer surface is flush with or 0.030 in. (0.76 mm) below the bushing bore inside surface.
5. Lubricate the bearing with new transmission fluid.

SHIFT MECHANISM

To inspect and service the shift shaft assembly, the transmission must be disassembled as described in this chapter. The shift lever can be removed by loosening the pinch bolt. Tighten the pinch bolt to 90-110 in.-lb. (10-12 N•m).

Table 1 TRANSMISSION SPECIFICATIONS

| | |
|--|--------|
| Primary drive sprockets (engine-to-transmission) | |
| Number of gear teeth | |
| Engine sprocket | 35 |
| Clutch sprocket | 56 |
| Ratio | 1.60:1 |
| Final drive sprockets | |
| (transmission-to-rear wheel)–1991-1992 models | |
| Number of sprocket teeth | |
| Transmission sprocket | |
| Chain drive | 21 |
| Belt drive | |
| 883 models | 27 |
| 1200 models | 29 |
| Rear wheel sprocket | |
| Chain drive | 48 |
| Belt drive | 61 |
| Ratio | |
| 883 Standard and Hugger models | 2.29:1 |
| 883 Deluxe models | 2.26:1 |
| 1200 models | 2.10:1 |
| Secondary drive belt | |
| Number of teeth | |
| 883 Deluxe models | |
| 1991 models (yellow color code) | 127 |
| 1992-2003 models (orange color code) | 128 |
| 1200 models (orange color code) | 128 |
| Final drive sprockets | |
| (transmission-to-rear wheel)–1993-2003 models | |
| Number of sprocket teeth | |
| Transmission sprocket | |
| 883 models | 27 |
| 1200 models | 29 |
| Rear wheel sprocket | |
| | 61 |
| Ratio | |
| 883 models | 2.26:1 |
| 1200 models | 2.10:1 |
| Overall gear ratios (U.S. models) | |
| 1991-1992 883 Standard and Hugger models | |
| 1st | 10.16 |
| 2nd | 7.41 |
| 3rd | 5.44 |
| 4th | 4.45 |
| 5th | 3.66 |
| 1991-1992 883 Deluxe and all 1993-1994 883 models | |
| 1st | 10.04 |
| 2nd | 7.32 |
| 3rd | 5.38 |
| 4th | 4.39 |
| 5th | 3.61 |
| 1995-2003 883 models | |
| 1st | 9.71 |
| 2nd | 7.12 |
| 3rd | 5.18 |
| 4th | 4.26 |
| 5th | 3.61 |
| 1991-1994 1200 models | |
| 1st | 9.35 |
| 2nd | 6.82 |
| 3rd | 5.01 |
| 4th | 4.09 |
| 5th | 3.36 |
| 1995-2003 1200 models | |
| 1st | 9.04 |
| 2nd | 6.62 |
| 3rd | 4.82 |
| 4th | 3.97 |
| 5th | 3.36 |

(continued)

Table 1 TRANSMISSION SPECIFICATIONS (continued)

| | |
|---|------|
| Overall gear ratios (HDI models) | |
| 1993-2003 883 models | |
| 1st | 9.71 |
| 2nd | 7.12 |
| 3rd | 5.18 |
| 4th | 4.26 |
| 5th | 3.61 |
| 1993-1996 1200 models | |
| 1st | 9.04 |
| 2nd | 6.62 |
| 3rd | 4.85 |
| 4th | 3.96 |
| 5th | 3.25 |
| 1997-2003 1200 models | |
| 1st | 9.04 |
| 2nd | 6.62 |
| 3rd | 4.82 |
| 4th | 3.97 |
| 5th | 3.36 |
| Overall gear ratios (Switzerland models) | |
| 1993-1996 883 models | |
| 1st | 9.05 |
| 2nd | 6.60 |
| 3rd | 4.85 |
| 4th | 3.96 |
| 5th | 3.25 |
| 1993-1996 1200 models | |
| 1st | 8.43 |
| 2nd | 6.14 |
| 3rd | 4.51 |
| 4th | 3.68 |
| 5th | 3.03 |

Table 2 TRANSMISSION TORQUE SPECIFICATIONS

| | ft.-lb. | in.-lb. | N•m |
|--|----------------|----------------|------------|
| Transmission access door bolts* | – | 156-204 | 18-23 |
| Countershaft retainer collar screw* | – | 156-204 | 18-23 |
| Detent screw/nut | – | 156-204 | 18-23 |
| Shift lever pinch bolt | – | 90-110 | 10-12 |
| Lower shift shaft locknut | – | 90-110 | 10-12 |
| Upper shift shaft nut | – | 90-110 | 10-12 |
| *Apply threadlock (Loctite 242 or equivalent). | | | |

CHAPTER TEN

FUEL, EMISSION CONTROL AND EXHAUST SYSTEMS (1986-1987 MODELS)

This chapter covers fuel, emissions control and exhaust systems. Air filter service is covered in Chapter Three. **Table 1** and **Table 2** are at the end of the chapter.

Refer to *Safety* in Chapter One prior to working on the fuel system.

AIR FILTER BACKPLATE

Removal/Installation

Refer to **Figure 1**.

1. Remove the air filter element (Chapter Three).
2. Remove the three screws (**Figure 2**).
3. Remove the two bolts (**Figure 3**) and pull the backplate slightly away from the carburetor.
4. Disconnect the vent hose from the back of the backplate, then remove the backplate.
5. If necessary, replace the carburetor gasket (**Figure 4**).
6. Install by reversing the preceding steps while noting the following:
 - a. Tighten the backplate-to-cylinder head bolts to 120-144 in.-lb. (14-16 N•m).
 - b. Tighten the backplate-to-carburetor screws to 36-60 in.-lb. (4-7 N•m).

CARBURETOR

Operation

The carburetor atomizes fuel, and mixes it in correct proportions with the air drawn in through the air intake. At the primary throttle opening (idle), a small amount of fuel is siphoned through the pilot jet by the incoming air. As the throttle is opened further, the air stream begins to siphon fuel through the main jet and needle jet. The tapered needle increases the effective flow capacity of the needle jet as it is lifted, and occupies progressively less of the area of the jet. At full throttle, the carburetor venturi is fully open and the needle is lifted far enough to permit the main jet to flow at full capacity.

The choke circuit is a starting enrichment valve system. The choke knob under the fuel tank on the left side of the engine opens an enrichment valve. In the open position, the slow jet discharges a stream of fuel into the carburetor venturi enriching the mixture when the engine is cold.

The accelerator pump circuit reduces engine hesitation by injecting a fine spray of fuel into the carburetor intake passage during sudden acceleration.

Removal/Installation

1. Remove the air filter backplate as described in this chapter.

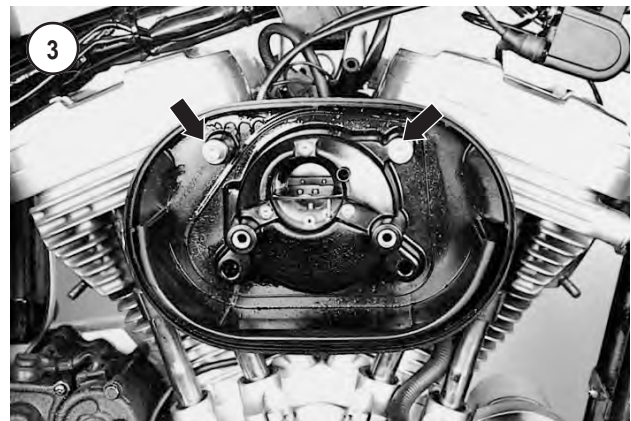
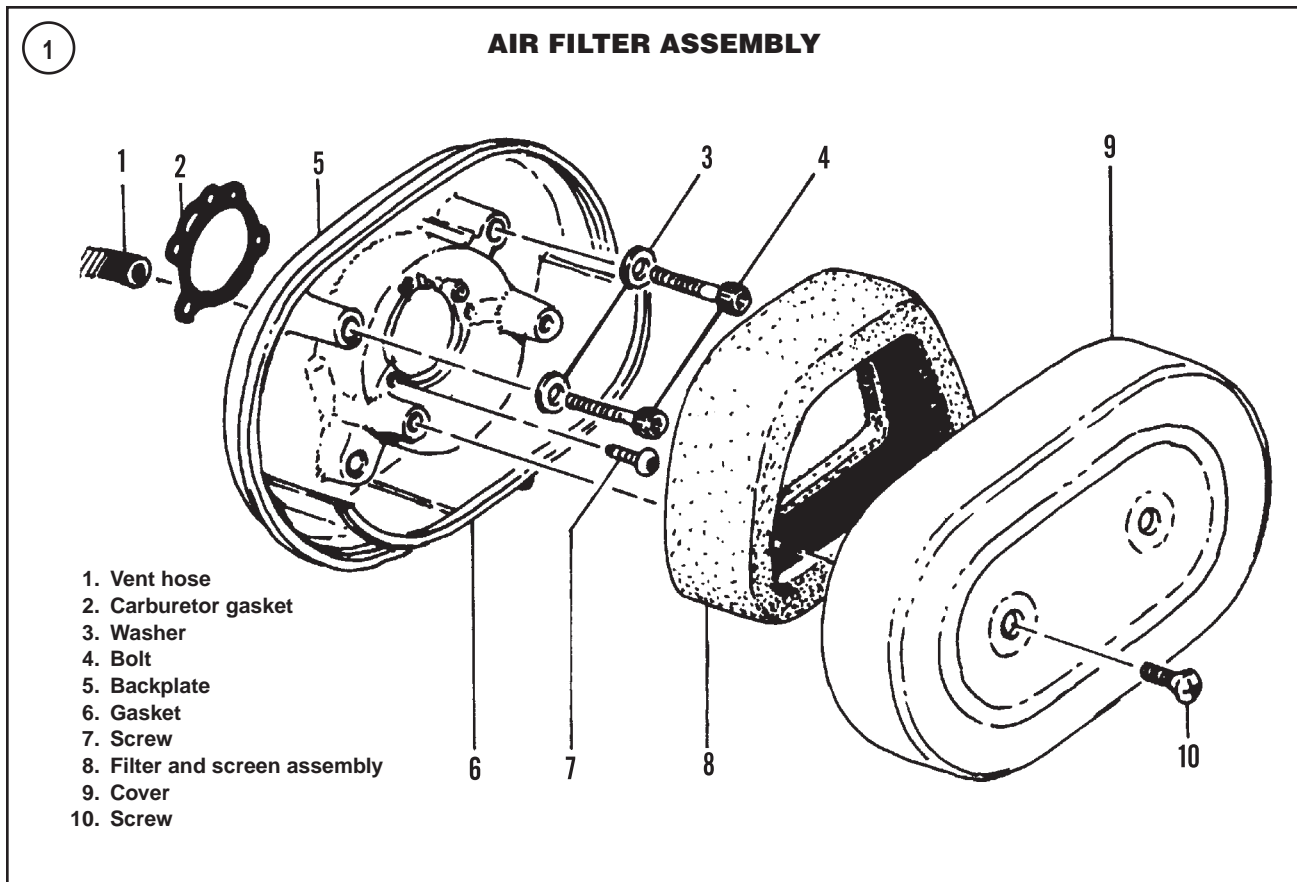

2. Turn the fuel supply off and disconnect the fuel line from the carburetor.

3. Remove the fuel tank as described in this chapter.

4. Label and disconnect the vacuum lines from the carburetor (**Figure 5**).

5. Disconnect the throttle cables from the carburetor (**Figure 6**).

6. Loosen the choke cable (**Figure 7**) setscrew at the carburetor and slide it out of its holder.

7. Drain as much of the gasoline from the carburetor assembly as possible. Store the carburetor to keep it clean until it is serviced or reinstalled.

8. Remove the carburetor mounting nuts and washers and remove the carburetor.





9. If necessary, remove the intake manifold as described in this chapter.

10. Cover the exposed manifold opening to prevent the entry of small objects.

11. Install by reversing the removal steps while noting the following:

- a. Tighten the intake manifold-to-carburetor nuts to 180-204 in.-lb. (20-23 N•m).
- b. Adjust the throttle cable (Chapter Three).
- c. Adjust the choke cable as described in *Periodic Maintenance* in Chapter Three.
- d. Adjust the idle speed as described in *Ignition Timing* in Chapter Three.

Disassembly/Assembly

Refer to **Figure 8**.

1. Remove the accelerator pump housing (**Figure 9**) at the bottom of the float bowl. Then remove the spring (**Figure 10**) and diaphragm (**Figure 11**).
2. Remove the O-ring (**Figure 12**) from the accelerator pump housing cover.
3. Remove the float bowl (**Figure 13**).
4. Remove the rubber boot (**Figure 14**) and O-ring (**Figure 15**) from the float bowl.
5. Remove the main jet (**Figure 16**).
6. Remove the plug (**Figure 17**) and remove the pilot jet (**Figure 18**).
7. Remove the float pin screw (**Figure 19**) and withdraw the float pin and float (**Figure 20**) as an assembly.
8. Detach the fuel valve from the float (**Figure 21**).
9. If necessary, tap the main nozzle (**Figure 22**) out with a punch.
10. Detach and remove the accelerator pump rod (**Figure 23**).
11. The throttle (**Figure 24**) and choke (**Figure 25**) valve assemblies are matched to the individual carburetor during manufacturing. If these parts are damaged, the carburetor must be replaced. Do not remove them.
12. Installation is the reverse of the preceding steps while noting the following:
 - a. Check and adjust the float level before installing the float bowl. Refer to *Fuel Level Measurement* in this section.
 - b. Align the accelerating pump rod with the rubber boot and the pump housing during reassembly. Refer to **Figure 26**.

Inspection/Cleaning

CAUTION

Do not clean rubber, plastic or other non-metal parts in carburetor cleaner. The chemical will destroy these parts.

1. Clean all metal parts in a suitable carburetor cleaner. Follow the manufacturer's instructions.
2. Remove all parts from the cleaner and blow dry with compressed air. Make sure all residue has been removed from the float bowl (**Figure 27**). Blow out the jets with compressed air. Do not use a drill or piece of wire to clean them as minor gouges in a jet can alter the flow rate and the air/fuel mixture.
3. If the float is suspected of leaking, put it in a small container of water and push it down. If the float sinks or if bubbles appear indicating a leak, replace the float.
4. Check the float needle (**Figure 28**) and seat contact areas. Both contact surfaces should appear smooth without any damage. Replace both needle and seat as a set if any one part is damaged.

8

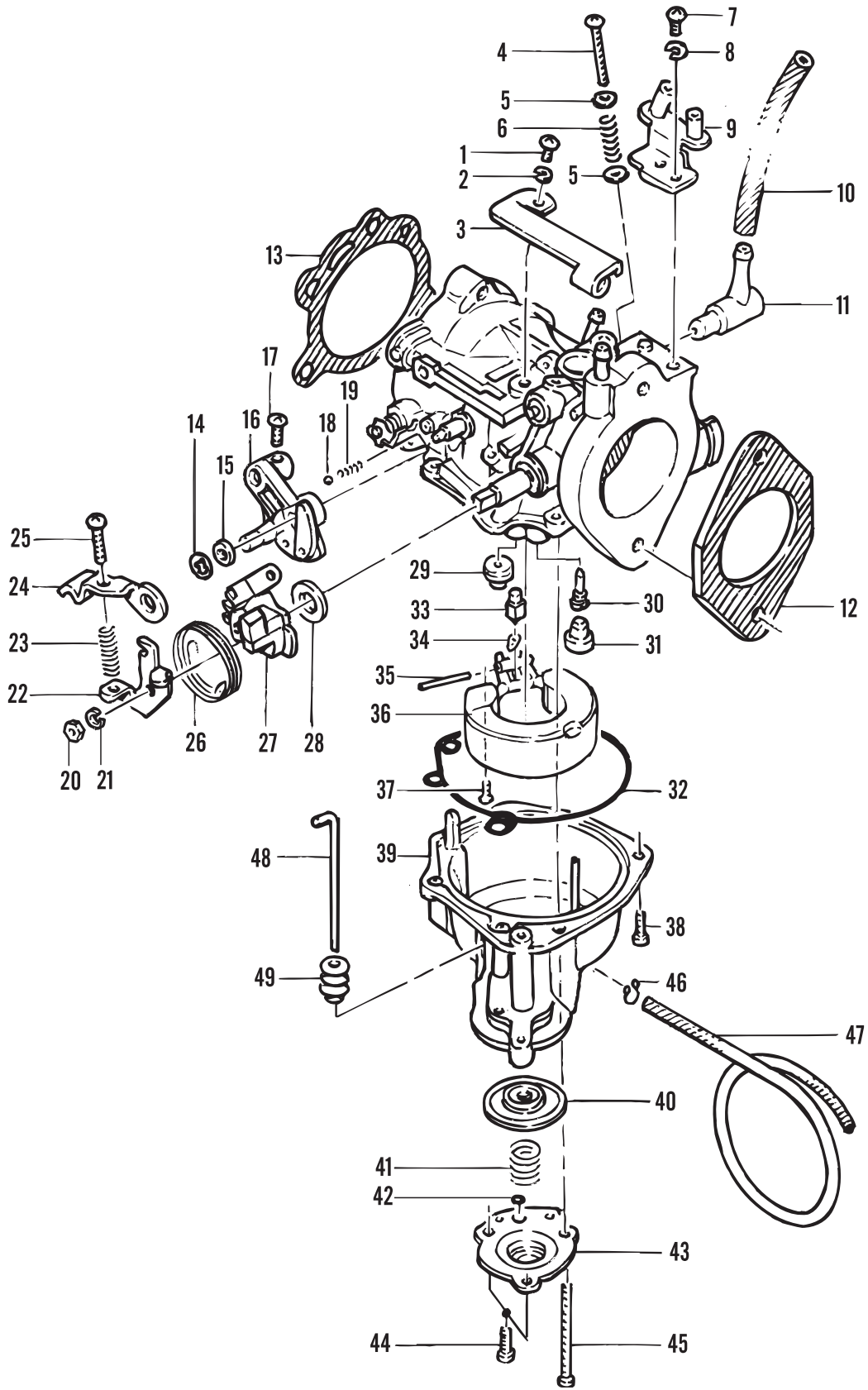

CARBURETOR

1. Screw
2. Washer
3. Choke cable bracket
4. Throttle stop screw
5. Washer
6. Spring
7. Screw
8. Washer
9. Throttle cable bracket
10. Fuel hose
11. Fitting
12. Gasket
13. Gasket
14. Clip
15. Washer
16. Fast idle cam
17. Screw
18. Detent ball
19. Spring
20. Nut
21. Lockwasher
22. Bracket
23. Spring
24. Fast idle lever
25. Screw
26. Spring
27. Rocker arm
28. Washer
29. Main jet
30. Low speed jet
31. Plug
32. Gasket
33. Fuel inlet valve
34. Clip
35. Float pin
36. Float
37. Float pin retaining screw
38. Screw
39. Float bowl
40. Accelerator pump diaphragm
41. Spring
42. O-ring
43. Accelerator pump housing
44. Screw
45. Screw
46. Clip
47. Overflow hose
48. Accelerator pump rod
49. Boot

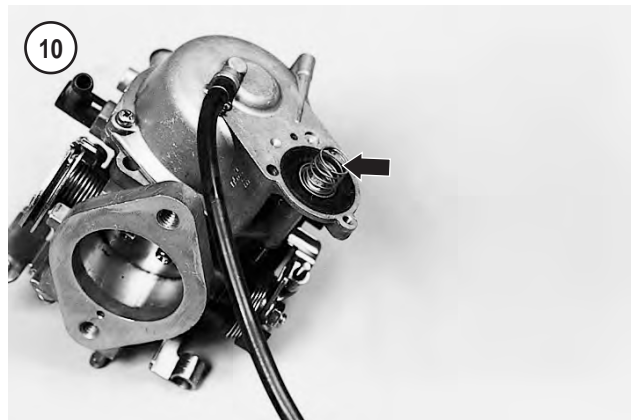
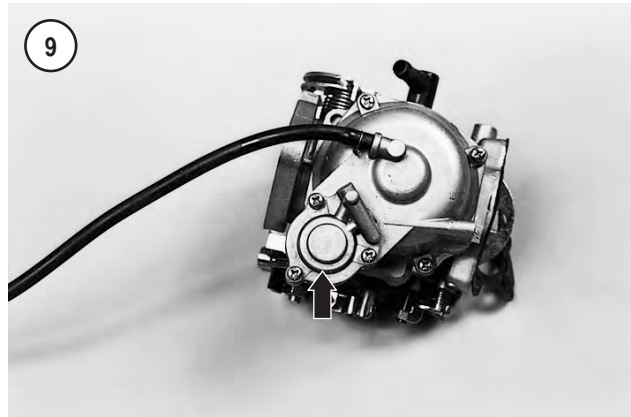

10

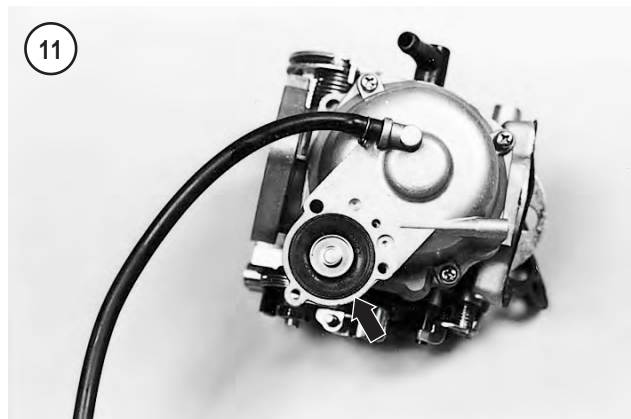

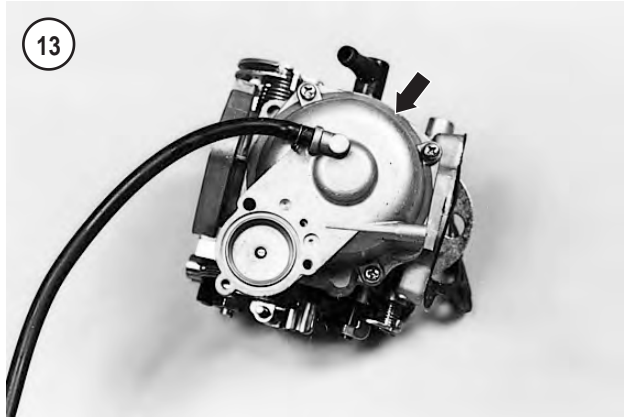

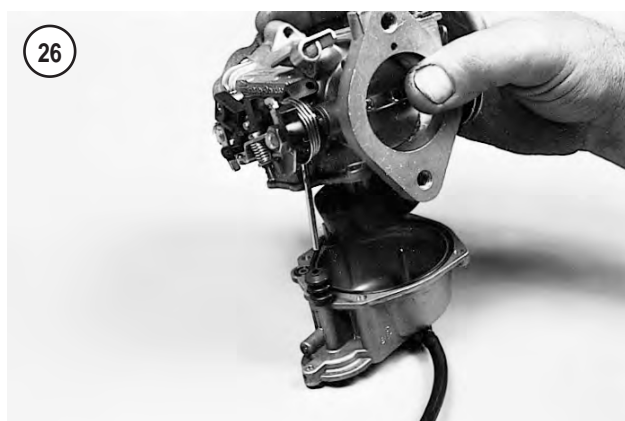
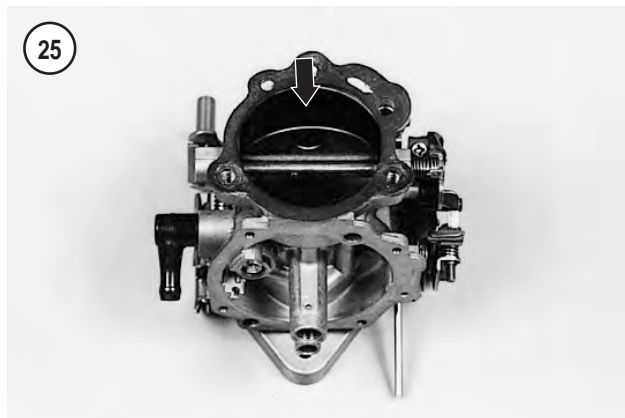

10

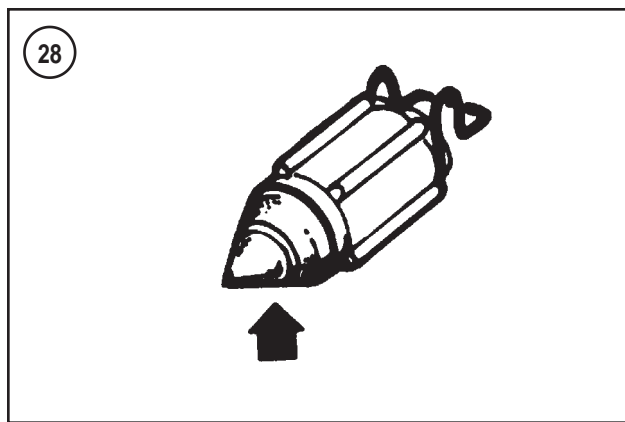



5. Inspect the accelerator pump diaphragm (**Figure 29**) for holes and cracks. Replace if necessary.
6. Replace the accelerator pump rod if bent or worn thin at any point.
7. Replace all O-rings. Replace all gaskets.

Fuel Level Measurement

1. Remove the carburetor as described in this section.

NOTE

*It is not necessary to remove the accelerator pump cover (A, **Figure 30**) when removing the float bowl. However, it is necessary to remove the one long accelerator pump/float bowl screw (45, **Figure 8**).*

2. Remove the float bowl (B, **Figure 30**).
3. Turn the carburetor to position the float bowl as indicated in **Figure 31**. Measure the float height from the float bowl gasket surface to the top float surface. The measurement should be 0.63-0.67 in. (16.0-17.0 mm). If incorrect, perform the following:
 - a. Remove the float pin screw (**Figure 32**) and withdraw the float pin and float (**Figure 33**) as an assembly.
 - b. Detach the fuel valve from the float (**Figure 21**).
 - c. Bend the float tang (**Figure 34**) to adjust.
 - d. Reinstall the float and recheck the float height.
4. Reinstall the float bowl and install the carburetor as described in this section.

INTAKE MANIFOLD

Removal/Installation

Refer to **Figure 35**.

1. Remove the carburetor as described in this chapter.

NOTE

It may be necessary to use a ball-end type or shortened Allen wrench for access to the intake manifold bolts.

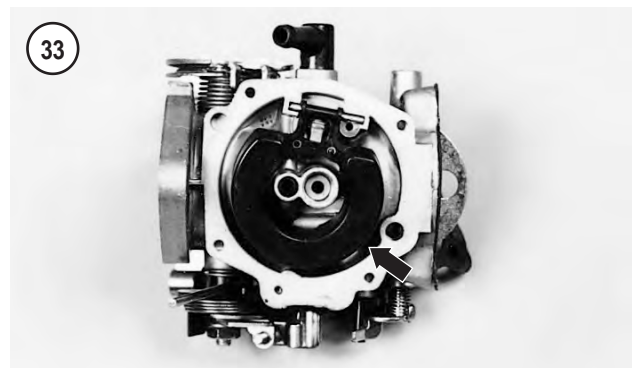
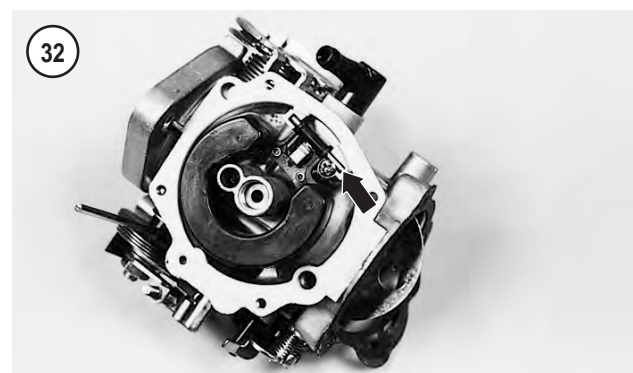
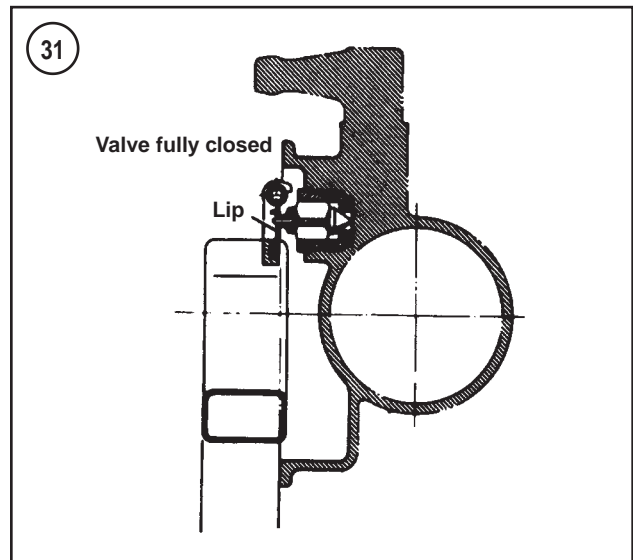
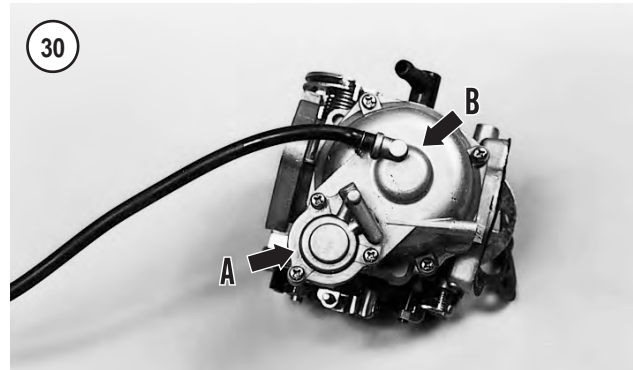

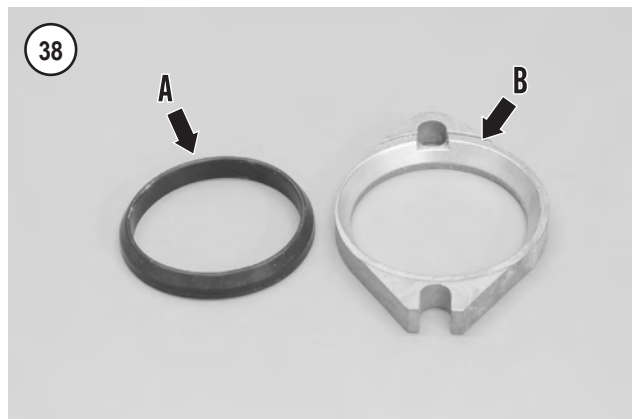
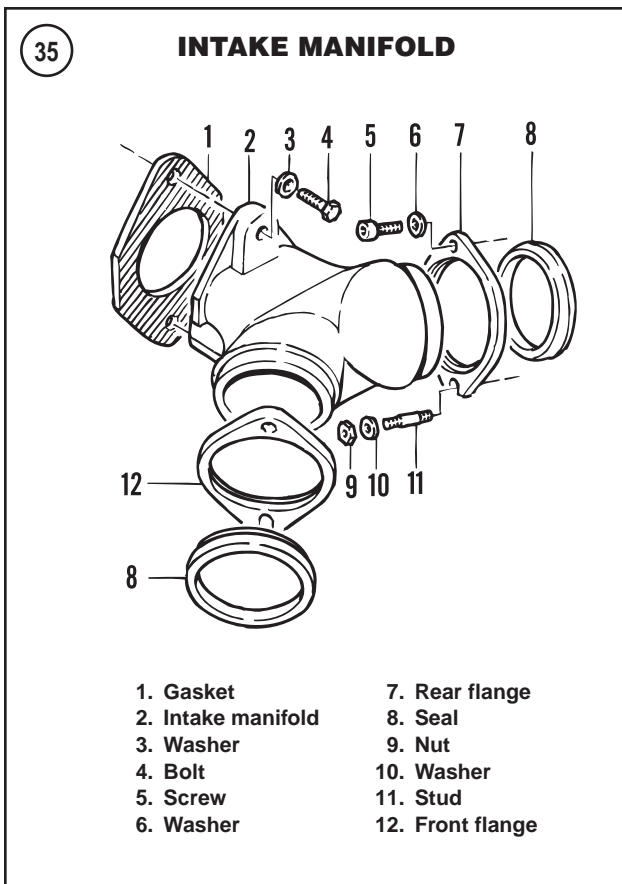

10

2. Remove the bolts and nuts securing the intake manifold (Figure 36) to the cylinder heads.

NOTE

The front and rear intake manifold flanges are different. If the flanges are not marked (Figure 37), label them with an F and R to re-install them in the correct location.

3. Remove the intake manifold, flanges and manifold seals.

4. Inspect the intake manifold. Inspect the intake manifold seals (A, Figure 38) for wear, deterioration or other damage. Replace the seals as a set if necessary.

5. Install the carburetor and spacer on the intake manifold. Tighten the intake manifold-to-carburetor mounting bolts to 180-204 in.-lb. (20-23 N•m).

6. Install the flanges and seals onto the intake manifold. Note that the seals (A, Figure 38) and flanges (B) have a tapered side. Fit the seal taper into the flange taper. Be sure the correct flange (F or R) is located at the front or rear of the manifold.

7. Install the intake manifold onto the cylinder head intake ports. The slotted ends of the flanges must point to the left.

8. Make sure the front and rear seals seat squarely against the cylinder head mating surfaces.

9. Install the intake manifold mounting bolts and nuts. Tighten the bolts and nuts to 72-120 in.-lb. (8-14 N•m).

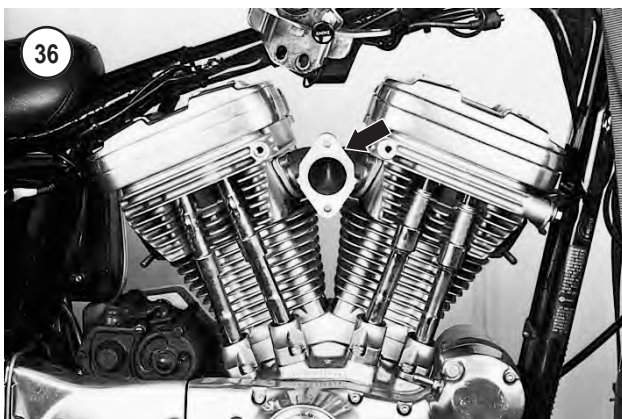

10. Complete carburetor installation as described in this chapter.

FUEL HOSE AND CLAMPS

CAUTION

Discard removed crimp-type hose clamps. Do not attempt to reuse removed clamps.

The fuel supply hose between the fuel valve and carburetor is secured at the hose ends with non-reusable hose clamps (A, **Figure 39**). Use diagonal pliers or other suitable tool to separate the clamp bands, then remove the clamp. Use hose clamp pliers (part No. HD- 97087-65B or equivalent) to compress the clamp bands during installation. A screw-type hose clamp may be substituted in place of the original equipment hose clamp.

NOTE

*End cutting pliers (B, **Figure 39**) may be modified to compress the band clamps. Be sure to test the performance of the tool by checking the fit and integrity of the installed clamp.*

THROTTLE AND IDLE CABLES

Removal/Installation

Refer to **Figure 40**.

1. Remove the fuel tank as described in this chapter.
2. Remove the air filter backplate as described in this chapter.
3. Loosen the two cable adjuster locknuts and turn the cable adjusters (**Figure 41**) to obtain as much cable slack as possible.
4. Remove the throttle housing screws and separate the upper and lower housings.
5. Unhook the cables from the throttle grip and lower housing. Account for the ferrules from the ends of both cables.
6. Disconnect the throttle cables at the carburetor. See **Figure 42**.
7. Tie a piece of heavy string or cord to the end of the throttle cable at the carburetor. Wrap this end with masking or duct tape. Do not use an excessive amount of tape as it will be pulled through the frame loop during removal. Tie the other end of the string to the frame. The piece of string attached in the next step will be used to pull the new throttle cable back through the frame so it can be routed in the exact same position.
8. Pull the cable and attached string out through the frame loop, past the electrical harness and from behind the headlight housing. Make sure the attached string follows the same path as the cable through the frame.
9. Remove the tape and untie the string from the old cable.
10. Tie the string to the new throttle cable and wrap it with tape.

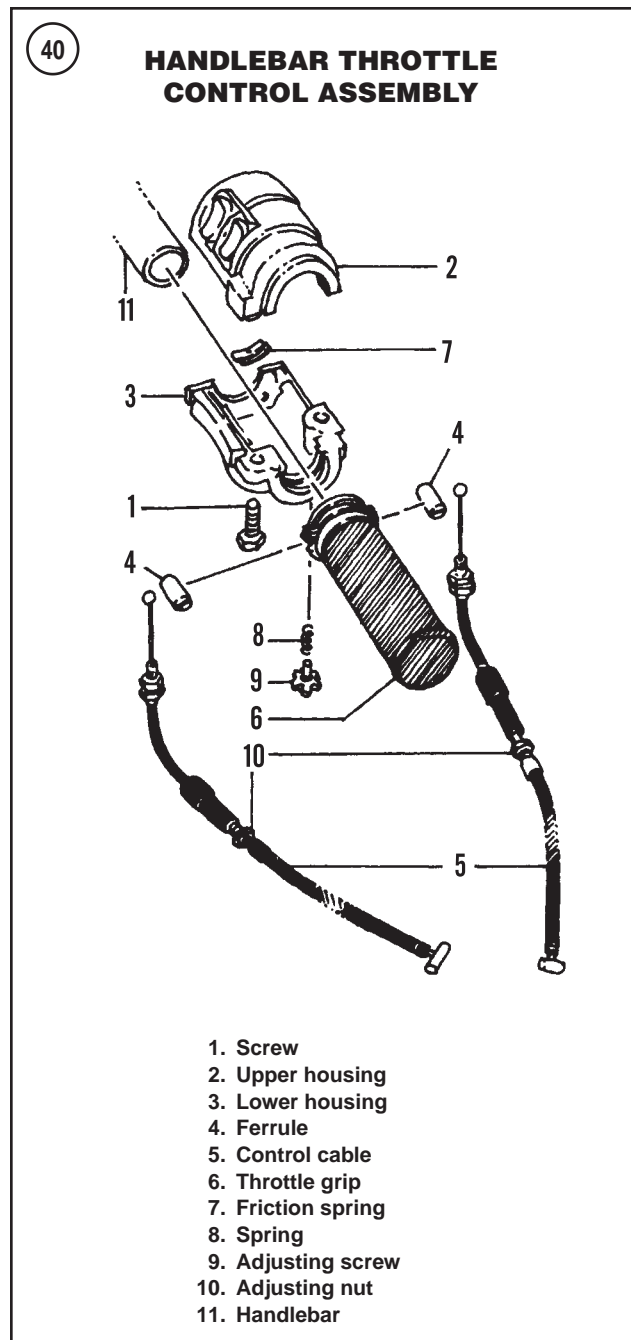
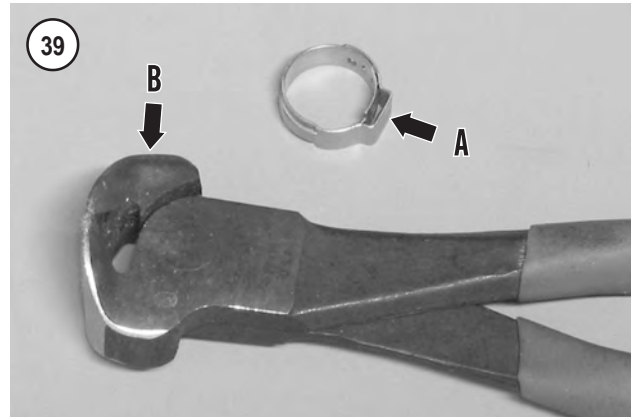

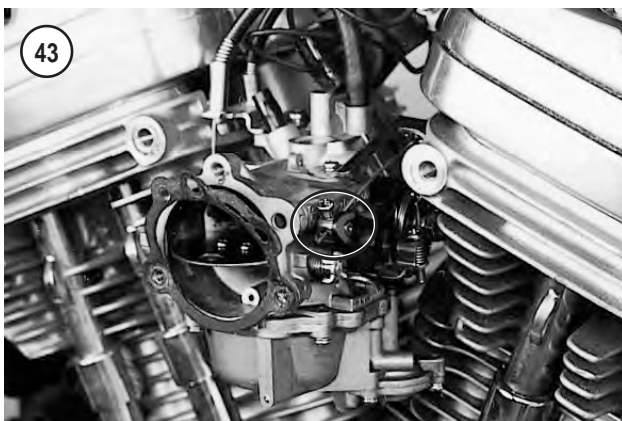

11. Pull the string back through the frame, routing the new cable through the same path as the old cable.
12. Remove the tape and untie the string from the cable and the frame.
13. Lubricate the new cables as described in the *Periodic Lubrication* in Chapter Three.
14. Slip the cable in through the carburetor bracket. Then, while holding the lever up with one hand, engage the cable at the carburetor lever.
15. Attach the throttle cables to the throttle/switch housing and install the housing.
16. Repeat for the other cable.
17. Operate the throttle grip and make sure the carburetor throttle linkage is operating correctly and with no binding. If operation is incorrect, check that the cables are attached correctly and there are no tight bends in the cables.
18. Adjust the throttle cables as described in Chapter Three.
19. Install all throttle attaching bolts or brackets.
20. Install the fuel tank.
21. Start the engine and turn the handlebar from side-to-side. Do not operate the throttle. If the engine speed increases as the handlebar assembly is turned, the throttle cables are routed incorrectly. Remove the fuel tank and recheck the cable routing.
22. Install the air filter backplate.

CHOKE CABLE

Removal/Installation

1. Remove the fuel tank as described in this chapter.
2. Remove the air filter backplate as described in this chapter.
3. Loosen the choke cable (**Figure 43**) setscrew on the carburetor and slide it out of its holder.
4. Loosen the choke nut at the choke knob (**Figure 44**) and remove the nut and choke knob.
5. Remove the choke cable.
6. Install by reversing the preceding steps.
7. Adjust the choke cable as described in this section.

Adjustment

1. Remove the air filter backplate as described in this chapter.
2. Check that the choke valve (**Figure 45**) operates in the positions shown by the choke knob in **Figure 46**.
3. If necessary, adjust the choke by loosening the nuts at the choke knob and adjusting the length of the cable. Tighten the nuts and recheck.

FUEL TANK

WARNING

Some fuel may spill from the fuel tank hose during this procedure. Because gasoline is extremely flammable and explosive, perform this procedure away from all open flames, including appliance pilot lights and sparks. Do not smoke or allow anyone to smoke in the work area, as an explosion and fire may occur. Always work in a well-ventilated area. Wipe up any spills immediately. Refer to **Safety** in Chapter One.

WARNING

Route the fuel tank vapor hoses so they cannot contact hot engine or exhaust components.

Removal/Installation

Refer to **Figure 47**.

1. Disconnect the battery negative lead (Chapter Twelve).
2. Turn the fuel valve (**Figure 48**) to the off position.
3. Remove the hose clamp and disconnect the fuel hose from the valve.
4. Drain the fuel tank as follows:
 - a. Connect a drain hose to the fuel valve and secure it with a hose clamp. Insert the end of the drain hose into a gas can.
 - b. Turn the fuel valve (**Figure 48**) to the reserve position so the fuel will start to flow into the gas can.
 - c. When fuel stops flowing through the hose, turn the fuel valve off and disconnect the drain hose.
5. Remove the front mounting bolt and washer (**Figure 49**).
6. Remove the rear mounting bolt and washer (**Figure 50**).
7. Lift and remove the fuel tank.

WARNING

Store the fuel tank in a safe place away from open flames or where it could be damaged.

8. Drain any remaining fuel into a gas can.
9. Inspect the fuel tank as described in this section.
10. Installation is the reverse of removal while noting the following:
 - a. Tighten the front and rear mounting bolts to 19 ft.-lb. (26 N•m).
 - b. Reconnect the fuel hose to the fuel valve and secure it with a new hose clamp as described in this chapter.
 - c. Refill the tank and check for leaks.

Inspection

1. Inspect the fuel hose and vent hose for cracks, deterioration or damage. Replace damaged hoses with the same type and size materials. The fuel lines must be flexible and able to withstand engine heat and vibration.

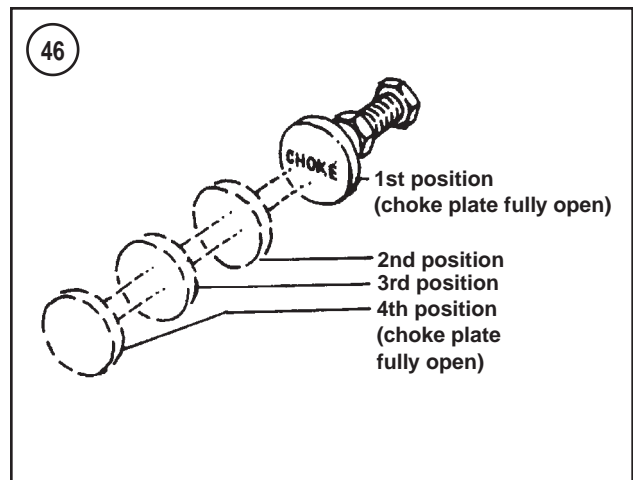

2. Check the fuel hose insulating sleeve for damage. Replace if necessary.
3. Check for damaged mounting brackets.
4. Inspect the fuel tank for leaks.
5. Remove the filler cap and inspect the tank for rust or contamination. If present, thoroughly flush and clean the tank. Replace the tank, if necessary.

FUEL SHUTOFF VALVE

The fuel shutoff valve is mounted on the left side of the fuel tank (**Figure 48**). A replaceable fuel filter is mounted at the top of the fuel shutoff valve.

Removal

Refer to **Figure 51**.

1. Remove the fuel tank as described in this chapter.
2. Place the fuel tank on a protective pad and position it so fuel will not spill out when removing the fuel shutoff valve.
3. Loosen the fuel valve nut and remove the fuel shutoff valve from the fuel tank. Drain residual gasoline from the tank after valve removal.

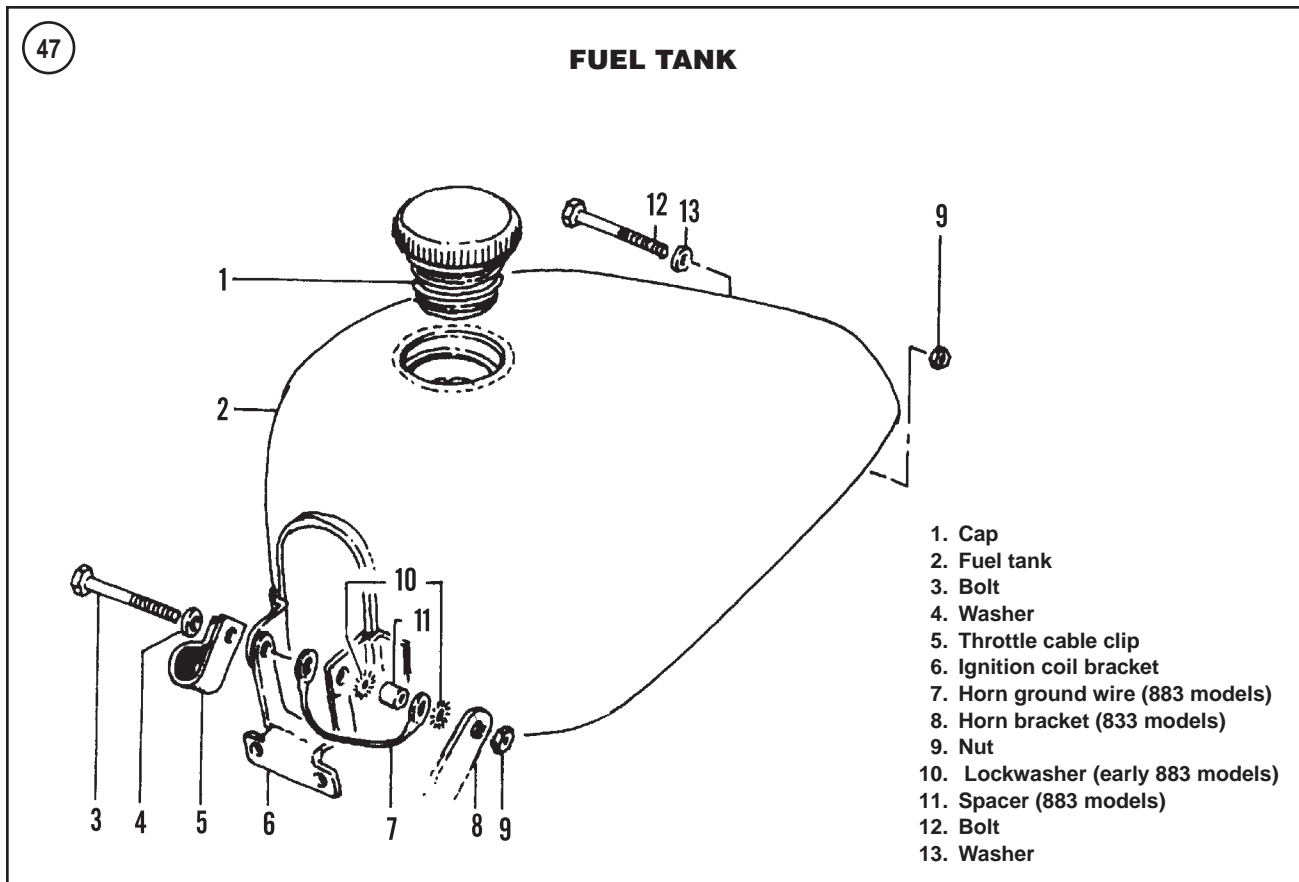

Cleaning and Inspection

1. Inspect the filter strainer mounted on top of the fuel valve (**Figure 51**). Remove contamination from the filter. Replace the filter if it is damaged.
2. Install a new filter gasket before installing the filter onto the fuel valve.
3. Remove all sealant residue from the fuel tank and fuel valve threads.

Installation

1. Install a new filter gasket onto the fuel shutoff valve, then install the filter.

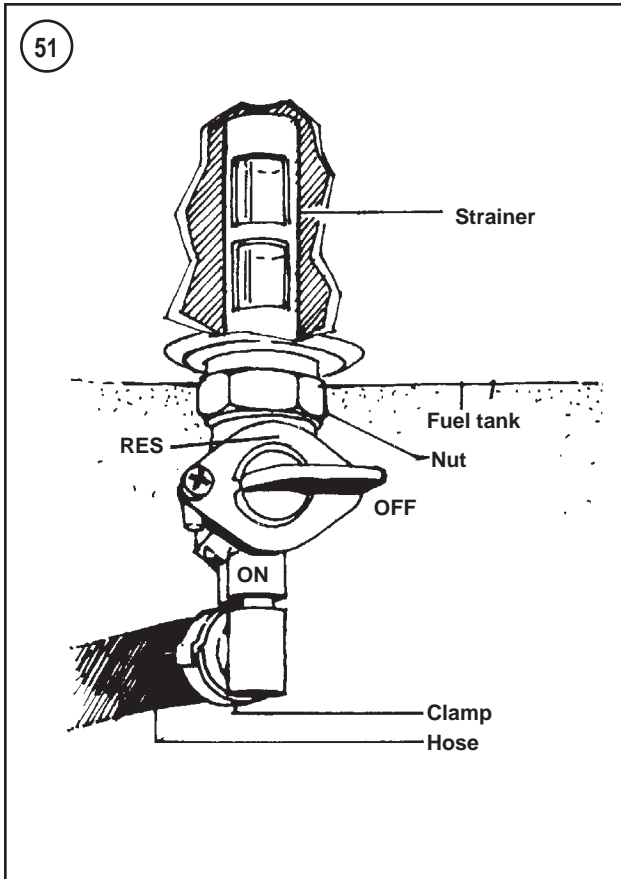

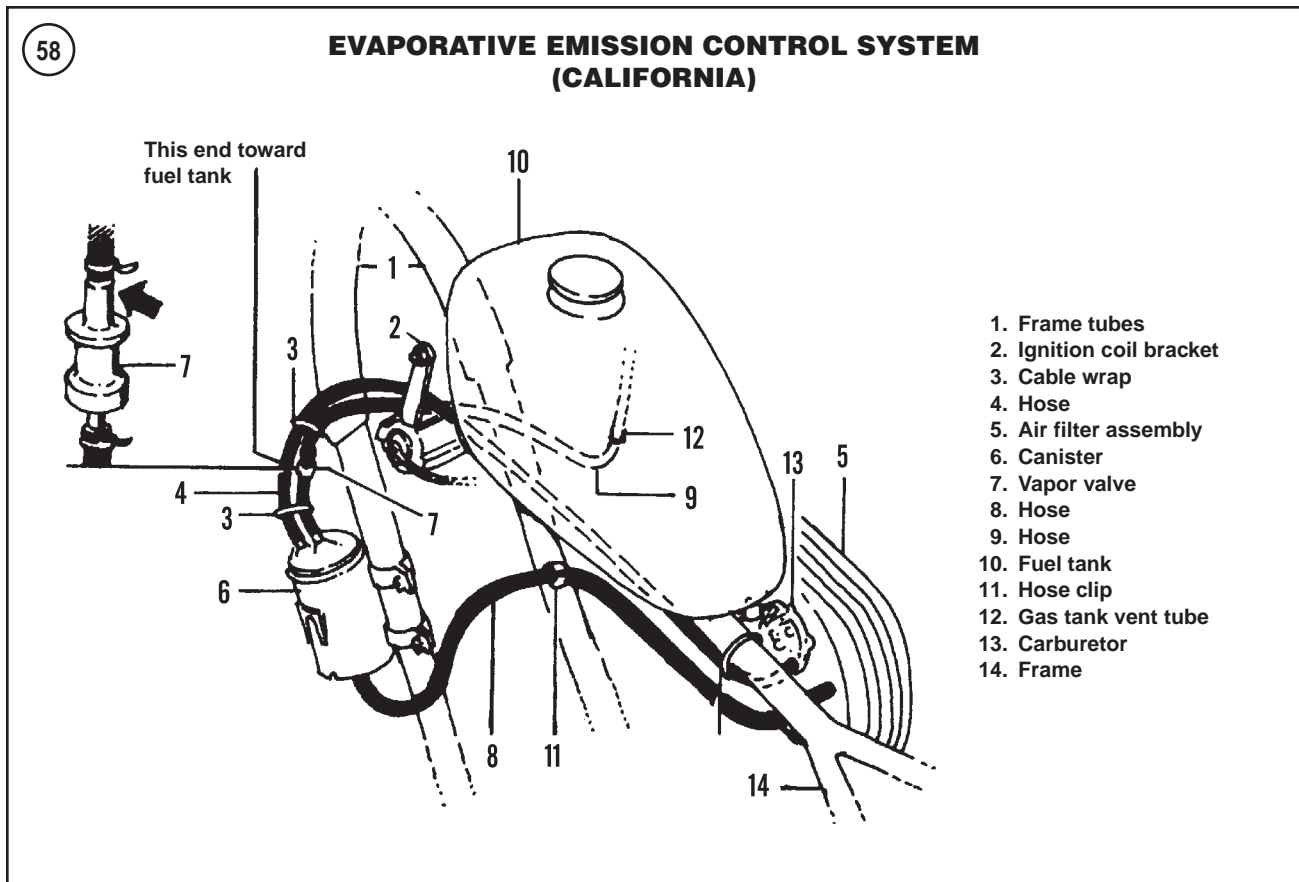

2. Coat the fuel valve threads with pipe sealant.
3. Insert the fuel valve into the tank and tighten the nut securely.
4. Install the fuel tank as described in this chapter.

EXHAUST SYSTEM

Removal/Installation

1. Place the motorcycle on the sidestand.
2. Loosen the muffler clamps and brackets (**Figure 52**).
3. Remove the muffler mount bolts (**Figure 53**).
4. Slide the mufflers (**Figure 54**) off the exhaust pipes.
5. Loosen and remove the exhaust pipe nuts from the cylinder head studs (**Figure 55**).
6. Remove the exhaust pipe assembly (**Figure 56**).
7. Install by reversing the preceding removal steps while noting the following:
 - a. Replace the exhaust port gaskets (**Figure 57**) if worn or damaged. During installation, make sure the gaskets are installed in the cylinder heads correctly.
 - b. Install all parts and finger tighten fasteners only. Then tighten the exhaust nuts at the cylinder head and work back to the mufflers. This will minimize exhaust leaks at the cylinder heads. Make sure all fasteners are tightened securely.

Inspection

1. Inspect all pipes for rust or corrosion.
2. Remove all rust from exhaust pipes and muffler mating surfaces.
3. Replace rusted or damaged exhaust system components.
4. Replace damaged exhaust pipe snap rings.
5. Replace damaged heat shields.

EVAPORATIVE EMISSION CONTROL SYSTEM (CALIFORNIA MODELS)

The evaporative emission control system prevents gasoline vapor from escaping into the atmosphere. When the engine is not running, the system directs the fuel vapor from the fuel tank through the vapor valve and into the carbon canister.

When the engine is running, these vapors are drawn through a purge hose and into the carburetor where they burn in the combustion chambers. The vapor valve also prevents gasoline vapor from escaping from the carbon canister if the motorcycle falls onto its side.

Carbon Canister Inspection

Refer to **Figure 58** and **Figure 59** for component placement and hose routing. Before removing the hoses from any of the parts, mark the hose and fitting.

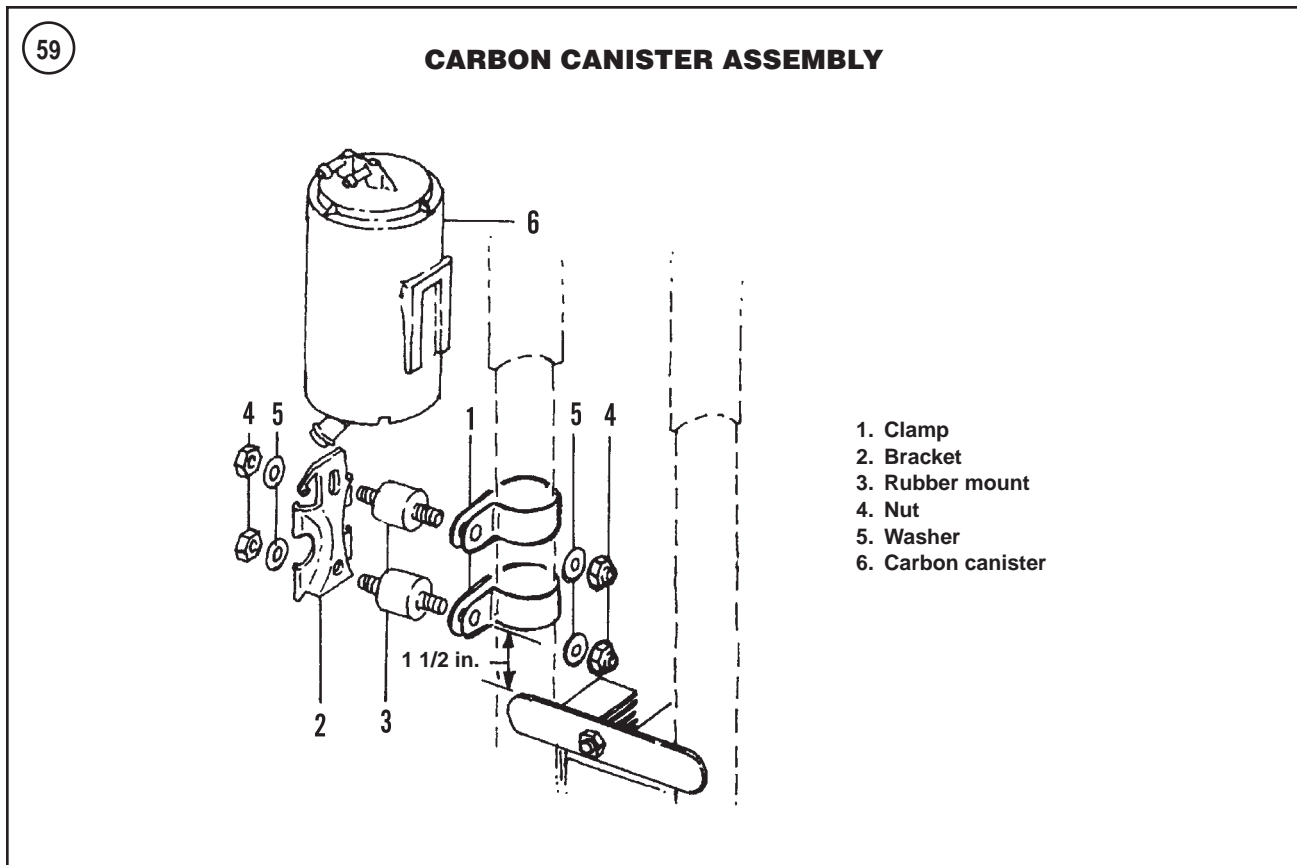

WARNING

Make sure the fuel tank vapor hoses are routed so they cannot contact hot engine or exhaust components.

1. Check all emission control lines and hoses to make sure they are correctly routed and connected.
2. Make sure there are no kinks in the lines or hoses. Also inspect the hoses and lines routed near engine hot spots for excessive wear or burning.
3. Check the physical condition of all lines and hoses in the system. Check for cuts, tears or loose connections. These lines and hoses are subjected to various temperatures and operating conditions, and eventually become brittle and crack. Replace damaged lines and hoses.
4. Check all components in the emission control system for damage, such as broken fittings.
5. If canister replacement is required, mark the hoses and prior to disconnecting the hoses from the canister.

Vapor Valve Replacement

The vapor valve (7, **Figure 58**) is part of the fuel pressure relief system. The fuel tank vapor expands as the fuel tank temperature rises. The vapor valve relieves excess pressure within the tank.

The lower hose is connected to the carbon canister.

1. Label the upper hose and lower hose where they are connected to the vapor valve fittings.
2. Disconnect the hoses from the vapor valve and remove the vapor valve.

WARNING

The vapor valve must be mounted in a vertical position in order to operate correctly.

3. Position the vapor valve with the long neck fitting at the top and attach the upper and lower hoses to the vapor valve.

Table 1 CARBURETOR SPECIFICATIONS

| | 883 models | 1 100 models |
|-----------------------------|---------------------------------|---------------------------------|
| Carburetor jet sizes | | |
| 1986 models | | |
| Main jet | 155 | 155 |
| Pilot jet | 52 | 52 |
| 1987 models | | |
| Main jet | 155 | 150 |
| Pilot jet | 52 | 52 |
| Float height | 0.63-0.67 in. (16.0-17.0 mm) | 0.63-0.67 in. (16.0-17.0 mm) |

Table 2 FUEL, EMISSION CONTROL AND EXHAUST SYSTEM TORQUE SPECIFICATIONS

| | ft.-lb. | in.-lb. | N•m |
|--|----------------|----------------|------------|
| Backplate-to-carburetor screws | – | 36-60 | 4-7 |
| Backplate-to-cylinder head bolts | – | 120-144 | 14-16 |
| Fuel tank mounting bolts | 19 | – | 26 |
| Intake manifold mounting bolts and nuts | – | 72-120 | 8-14 |
| Intake manifold-to-carburetor nuts | – | 180-204 | 20-23 |

CHAPTER ELEVEN

FUEL, EMISSION CONTROL AND EXHAUST SYSTEMS (1988-2003 MODELS)

This chapter covers fuel, emissions control and exhaust systems. Air filter service is covered in Chapter Three. **Tables 1** and **Table 2** are at the end of the chapter.

Refer to *Safety* in Chapter One prior to working on the fuel system.

AIR FILTER BACKPLATE

Removal/Installation

NOTE

*Early models are equipped with a foam-type filter. Later models are equipped with a paper-mesh filter as shown in **Figure 1**.*

1. Remove the air filter element (Chapter Three).
2. Remove the backplate bolts (A, **Figure 2**).

CAUTION

Do not remove the screws from the backplate unless the backplate requires replacement. Completely removing the screw damages the backplate insert sleeve threads.

3. Loosen the screws (B, **Figure 2**) 1 or 2 turns at a time in a crisscross pattern until they disengage from the carburetor holes. Remove the backplate and screws.

4. On California models, label and then disconnect the hoses from the backplate (**Figure 1**). Disconnect the butterfly valve solenoid wiring 4-pin connector.

5. If necessary, replace the carburetor gasket.

6. Install by reversing the preceding steps while noting the following:

- a. Install the backplate-to-carburetor screws first to align the backplate, but do not tighten the screws. On HDI models, use the air filter retaining screws, which also serve to secure the backplate to the carburetor.
- b. After aligning the backplate to the carburetor, loosely install the backplate-to-cylinder head bolts.
- c. Tighten the backplate-to-carburetor screws to 36-60 in.-lb. (4-7 N•m). On HDI models, tighten the air filter retaining screws to 20 in.-lb. (2 N•m).
- d. Tighten the backplate-to-cylinder head bolts to 120-144 in.-lb. (14-16 N•m).

CARBURETOR

Operation

The carburetor atomizes fuel in correct proportions with the air drawn in through the air intake. At the primary throttle opening (idle), a small amount of fuel is siphoned through the pilot jet by the incoming air. As the throttle is opened further, the air stream begins to siphon fuel through

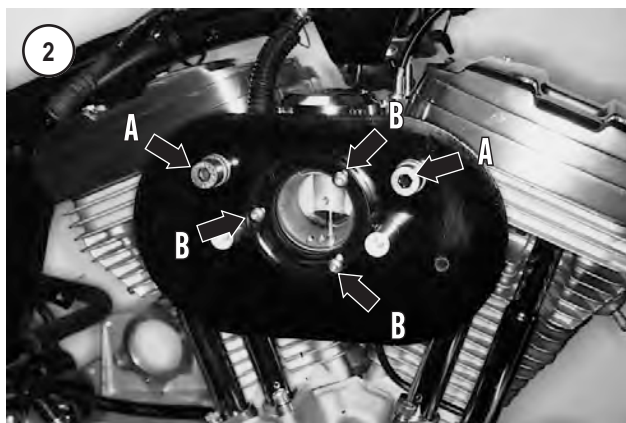
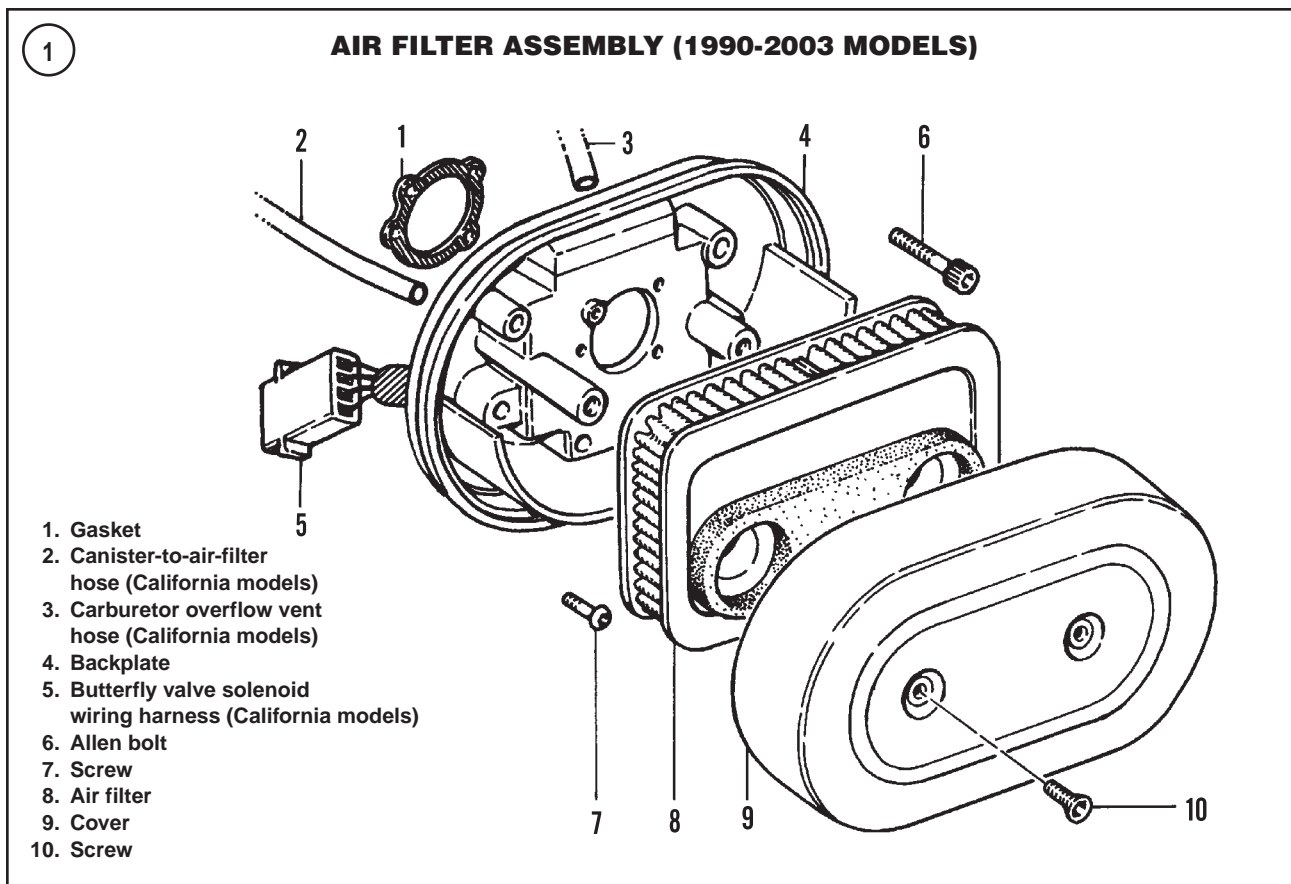

the main jet and needle jet. The tapered needle increases the effective flow capacity of the needle jet as it is lifted, and occupies progressively less of the area of the jet. At full throttle, the carburetor venturi is fully open and the needle is lifted far enough to permit the main jet to flow at full capacity.

The choke circuit is a starting enrichment valve system. The choke knob under the fuel tank on the left side of the engine opens an enrichment valve. In the open position, the slow jet discharges a stream of fuel into the carburetor venturi enriching the mixture when the engine is cold.

The accelerator pump circuit reduces engine hesitation by injecting a fine spray of fuel into the carburetor intake passage during sudden acceleration.



Removal/Installation

1. Remove the air filter (Chapter Three).
2. Remove the air filter backplate as described in this chapter.
3. Turn the fuel valve off.

NOTE

It is easier to remove the enricher cable while it is attached to the carburetor.

4. Remove the enricher bracket mounting screw (**Figure 3**) and allow the bracket to rest on top of the intake manifold.

5. Push the rubber boots (**Figure 4**) off the throttle cable adjusters.
6. Loosen the throttle friction screw .
7. Loosen both throttle cable adjuster jam nuts (A, **Figure 5**), then turn the cable adjusters (B).

NOTE

*Refer to **Fuel Hose And Clamps** in this chapter when disconnecting the fuel hose.*

8. Label and then disconnect the fuel supply hose from the carburetor fitting.
- 9A. On 1988-1990 models, loosen the hose clamp, then pull the carburetor out of the manifold.
- 9B. On 1991-2003 models, twist and pull the carburetor off the seal ring and intake manifold.
10. Identify and label all carburetor hoses for correct reinstallation. Then disconnect the hoses from the carburetor.
11. There are two different throttle cables. Label the two cables at the carburetor before disconnecting them. One is the throttle control cable (A, **Figure 6**) and the other is the idle control cable (B). Disconnect the throttle control cable and the idle control cable from the carburetor cable guide and the throttle pulley.
12. Drain the gasoline from the carburetor.
13. If necessary, service the intake manifold as described in this chapter.
14. Inspect the manifold seal ring (**Figure 7**) for wear, hardness, cracks or other damage. Replace if necessary.
15. Cover the intake manifold opening.

Installation

1. If removed, seat the manifold seal ring (**Figure 7**) onto the intake manifold. Make sure it is correctly seated to avoid a vacuum leak.
2. Route the starting enrichment valve cable between the cylinders and towards the mounting bracket on the left side.
3. Connect the idle cable to the carburetor as follows:
 - a. The idle cable has the small spring (C, **Figure 6**) on the end of the cable.
 - b. Insert the idle cable sheath into the rear cable bracket guide on the carburetor.
 - c. Attach the end of the idle cable (B, **Figure 6**) to the throttle pulley.
4. Connect the throttle cable to the carburetor as follows:
 - a. Insert the throttle cable sheath into the front cable bracket guide on the carburetor.
 - b. Attach the end of the throttle cable (A, **Figure 6**) to the throttle pulley.
5. Operate the throttle a few times. Make sure the throttle pulley operates smoothly with no binding. Also make sure both cable ends are seated squarely in the cable bracket guides and in the throttle pulley.
6. Connect any disconnected hoses to the carburetor.

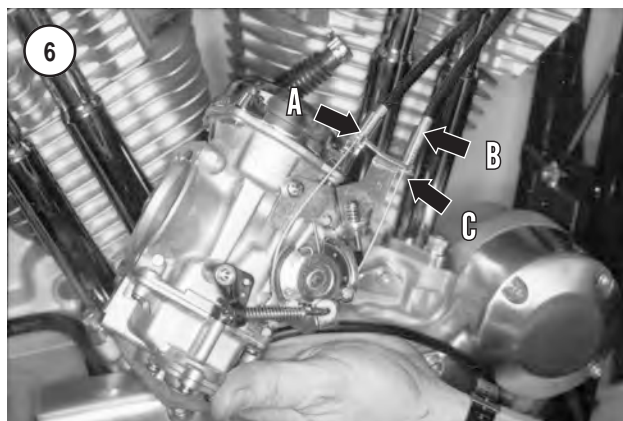
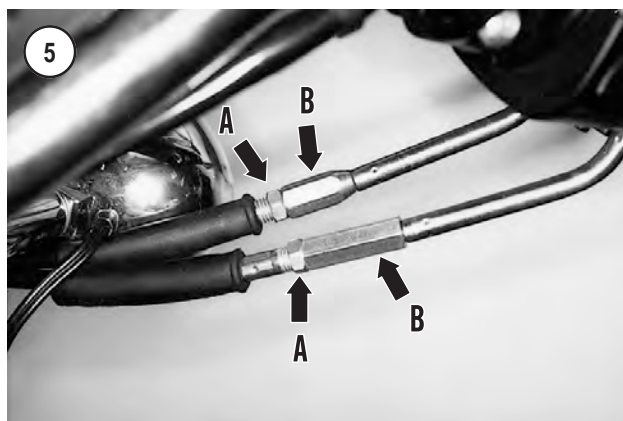

CAUTION

The carburetor must fit squarely onto the intake manifold. If it is misaligned, it may damage the manifold seal ring, resulting in a vacuum leak.

NOTE

To ease installation of the carburetor, apply a light coat of liquid dish soap to the carburetor spigot before insertion into the manifold seal ring .

- 7A. On 1988-1990 models, insert the enricher cable (**Figure 3**) between the cylinders and above the intake man-



ifold. Install the hose clamp around the carburetor spigot, then install the carburetor into the intake manifold until it bottoms (**Figure 8**). Position the carburetor so it sits square and vertical with the manifold. Tighten the hose clamp.

7B. On 1991-2003 models, insert the enricher cable (**Figure 3**) between the cylinders and above the intake manifold. Align the carburetor with the intake manifold and push the carburetor into the manifold seal ring until it bottoms (**Figure 8**). Position the carburetor so it sits square and vertical with the manifold.

8. Secure the enricher bracket to the cylinder head bracket with its mounting screw (**Figure 3**).

9. Install the air filter backplate as described in this chapter.

WARNING

Make sure that all evaporative emission control hoses are routed so they cannot contact any hot engine or exhaust component. These hoses contain flammable vapors. If a hose melts from contacting a hot part, leaking vapors may ignite, causing severe motorcycle damage and rider injury.

CAUTION

Interchanging the vacuum hose connections will reduce engine performance

10. On California models, reconnect all evaporative emissions control system hoses following notes made prior to

disassembly. Refer to the *Evaporative Emissions Control System* in this chapter to confirm the correct connection of each hose.

11. Adjust the throttle and enricher cables (Chapter Three).

Disassembly

Refer to **Figure 9**.

1. Unscrew and remove the enricher cable (**Figure 10**).
2. If not previously removed, remove the throttle cable bracket screw and lockwasher and remove the bracket (**Figure 11**).

3A. On 1988 models, remove the float bowl from the carburetor. Account for the float bowl O-ring.

NOTE

An accelerator pump is installed on 1989-2003 models. Note the position of the throttle and pump rods when removing the float bowl.

3B. On 1989-2003 models, remove the float bowl as follows:

- Remove the screws and washers securing the float bowl (**Figure 12**) to the carburetor. Remove the float bowl from the carburetor while allowing the pump rod (**Figure 13**) to withdraw from the boot on the bowl.
- Disconnect the pump rod from the lever assembly on the carburetor (**Figure 14**).
- Pull the boot (**Figure 15**) off the float bowl.

4A. On 1988-1991 models, remove the float pin (**Figure 16**) and lift off the float and needle valve assembly (**Figure 17**).

4B. On 1992-2003 models, remove the float pin (**Figure 18**) and lift off the float and needle valve assembly (**Figure 19**).

5. The main jet is screwed into the top of the needle jet holder. Either remove the main jet (**Figure 20**) and then the needle jet holder (**Figure 21**) or remove the needle jet holder with the main jet attached.

6. Remove the needle jet from the needle jet bore (**Figure 22**) in the carburetor.

CAUTION

If the screwdriver used to remove the pilot jet is too small it may damage the top of the jet. If necessary, grind a screwdriver tip to fit.

7. Remove the pilot jet (**Figure 23**).

8. Remove the remaining cover screws and washers and remove the cover (**Figure 24**) and spring (**Figure 25**).

9. Remove the vacuum piston (**Figure 26**) from the carburetor housing. Do not damage the jet needle sticking out of the bottom of the vacuum piston.

10. Remove the spring seat (A, **Figure 27**) and jet needle (B) from the vacuum piston.

11. On 1989-2003 models, remove the accelerator pump diaphragm using the following procedure:

- Remove the screws and lockwashers holding the pump cover (**Figure 28**) to the float bowl and remove the cover.

9

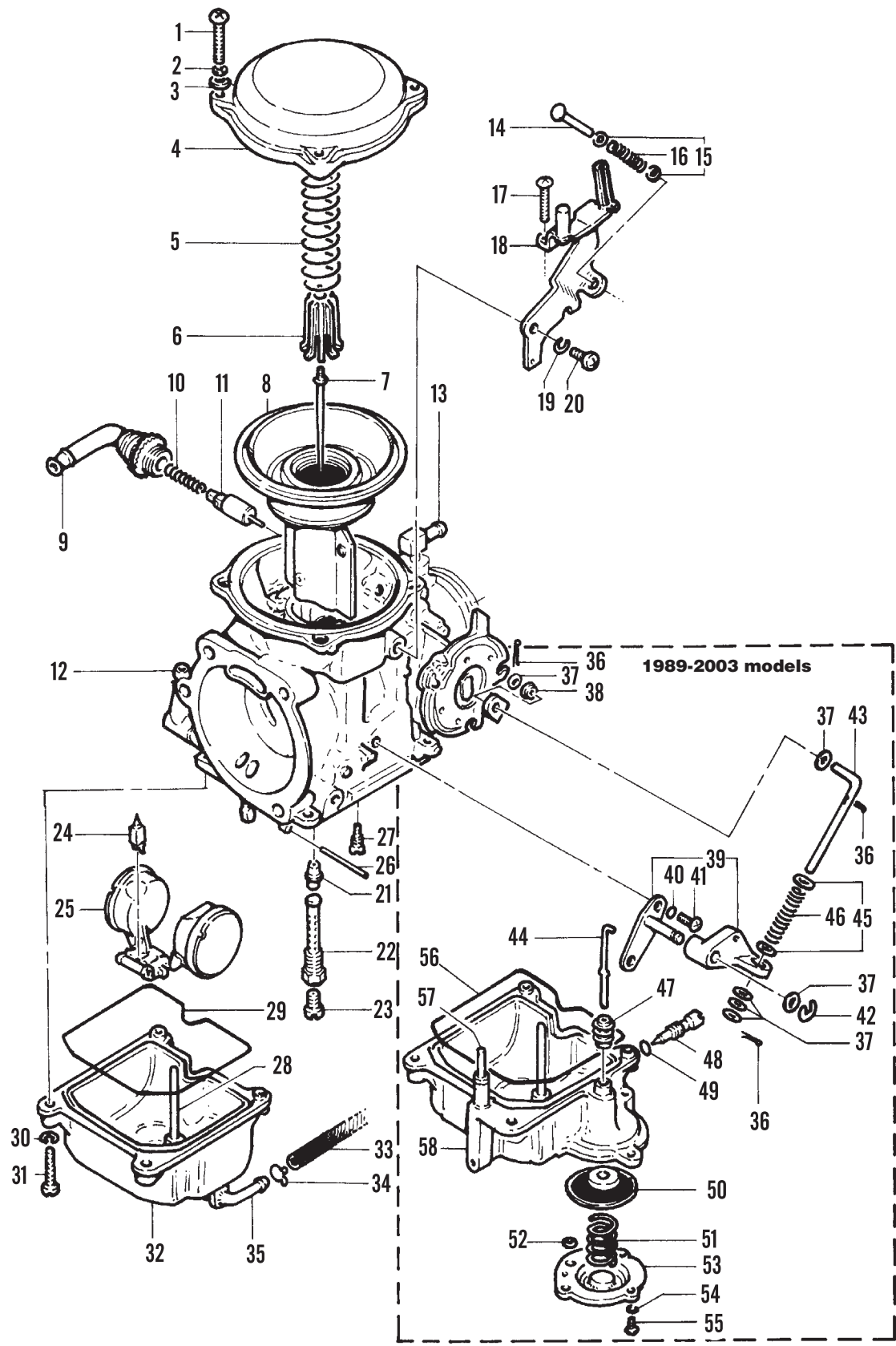

CARBURETOR

- | | |
|----------------------------|---|
| 1. Screw | 31. Screw |
| 2. Lockwasher | 32. Float bowl (1988 models) |
| 3. Flat washer | 33. Hose (1988 models) |
| 4. Cover | 34. Clamp (1988 models) |
| 5. Spring | 35. Fuel overflow fitting (1988 models) |
| 6. Spring seat | 36. Cotter pin |
| 7. Jet needle | 37. Washer |
| 8. Vacuum piston | 38. Roller |
| 9. Cable guide | 39. Pump lever assembly |
| 10. Spring | 40. Lockwasher |
| 11. Enrichener valve | 41. Screw |
| 12. Body | 42. E-clip |
| 13. Vacuum fitting | 43. Throttle rod |
| 14. Idle adjustment screw | 44. Pump rod |
| 15. Washers | 45. Washers |
| 16. Spring | 46. Spring |
| 17. Screw | 47. Boot |
| 18. Throttle cable bracket | 48. Drain screw |
| 19. Lockwasher | 49. O-ring |
| 20. Screw | 50. Diaphragm |
| 21. Needle jet | 51. Spring |
| 22. Needle jet holder | 52. O-ring |
| 23. Main jet | 53. Cover |
| 24. Fuel valve and clip | 54. Lockwasher |
| 25. Float | 55. Screw |
| 26. Pin | 56. O-ring |
| 27. Pilot jet | 57. Accelerator pump nozzle |
| 28. Overflow pipe | 58. Float bowl |
| 29. O-ring | |
| 30. Lockwasher | |

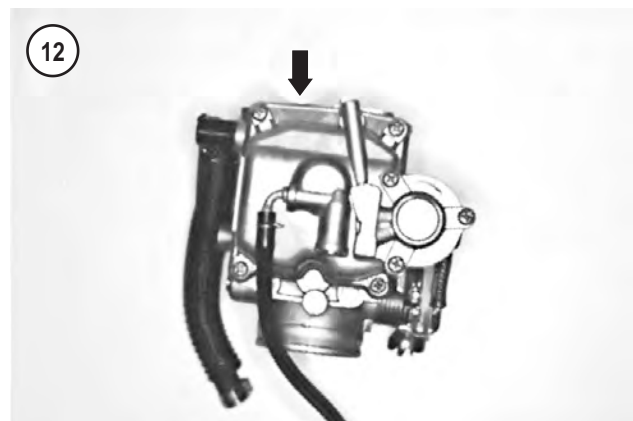

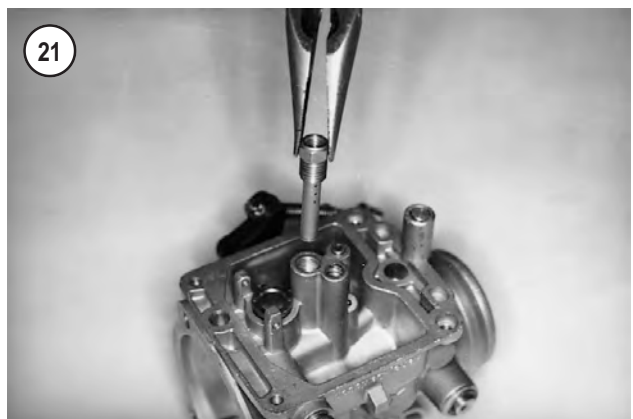
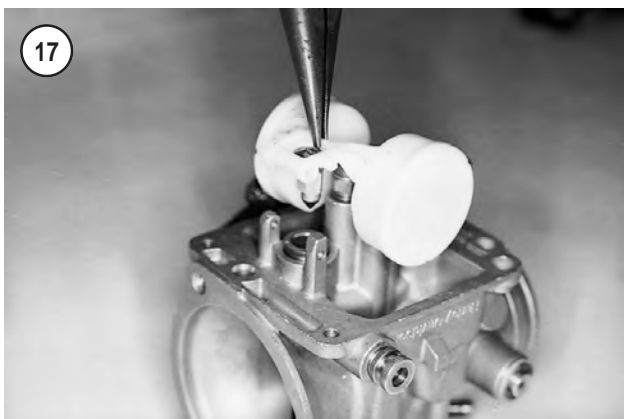
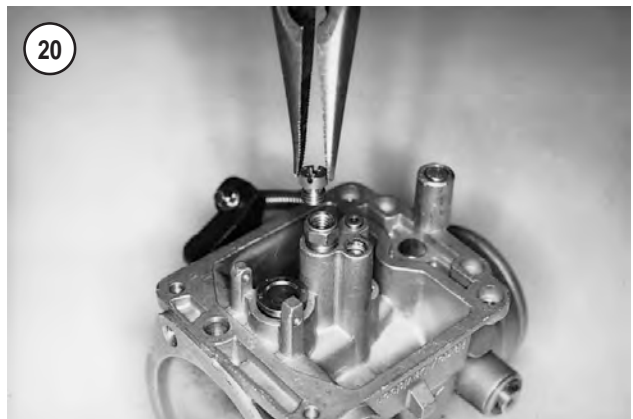
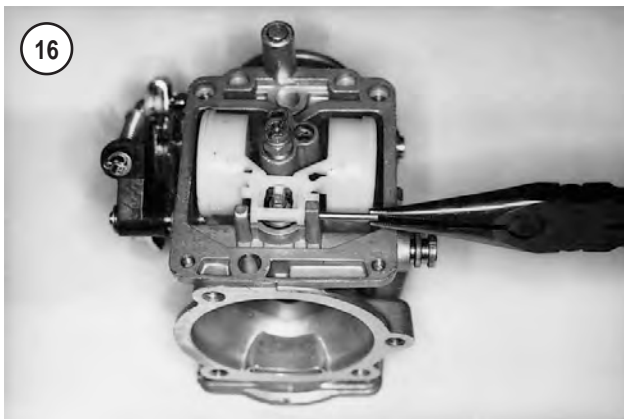
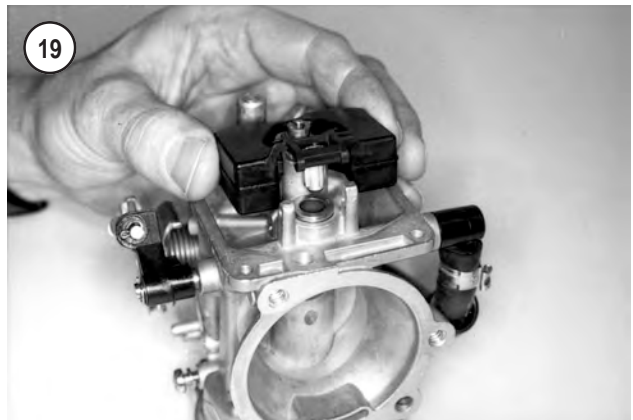

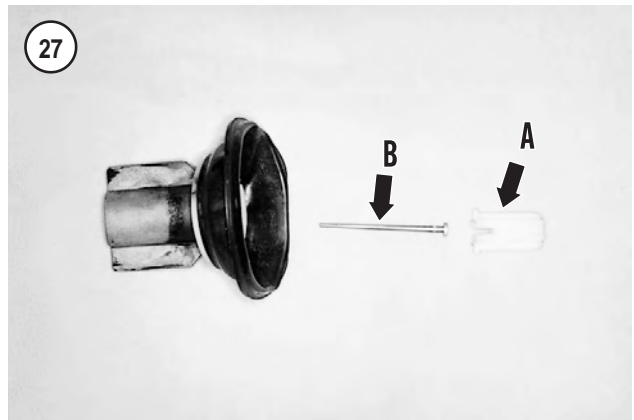
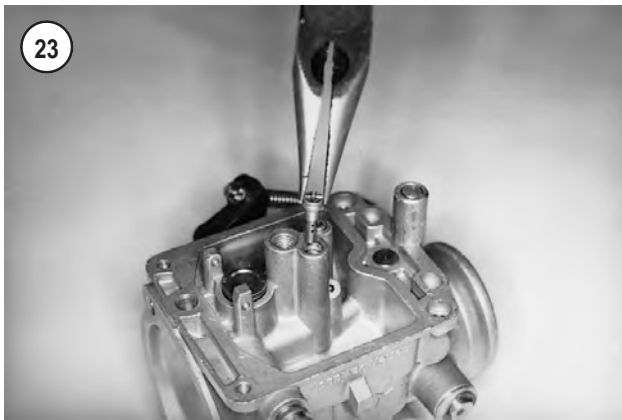
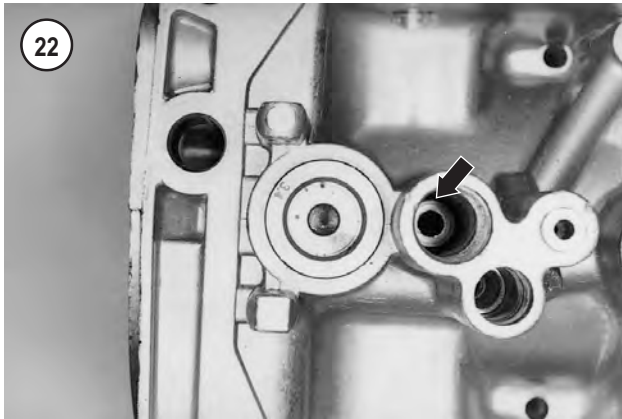

- b. Remove the pump cover O-ring (**Figure 29**).
- c. Remove the spring (A, **Figure 30**) and diaphragm (B).

NOTE
 Replacement parts are not available for the throttle plate (**Figure 31**) assembly. Do not loosen the screws or remove the throttle plate.

Inspection

CAUTION
 Do not clean rubber, plastic or other non-metal parts in carburetor cleaner. The chemical will destroy these parts.

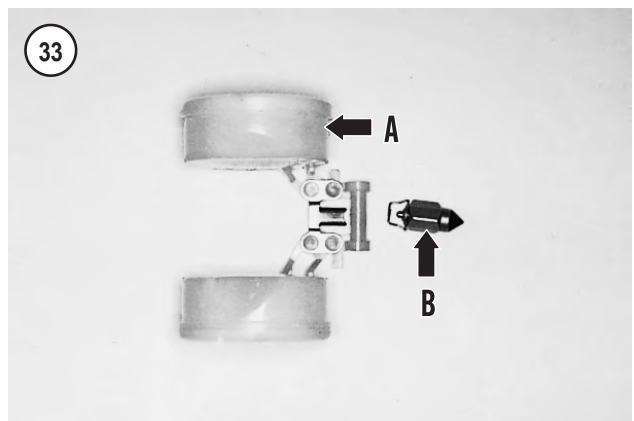
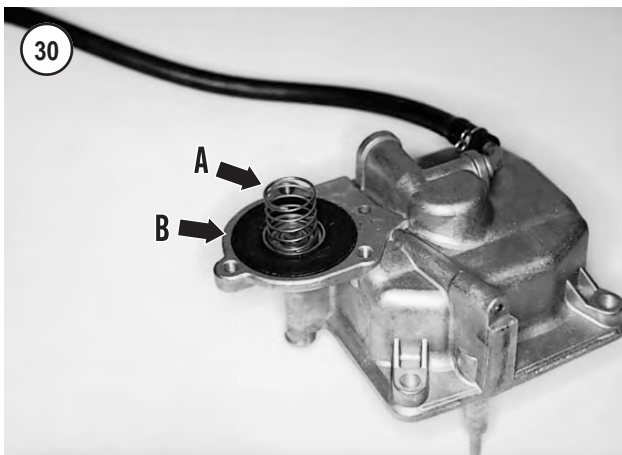
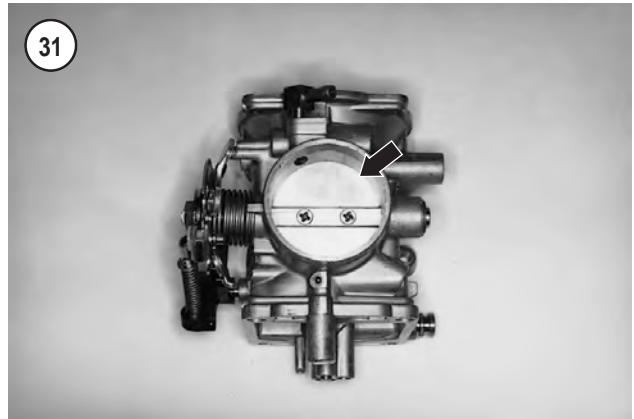
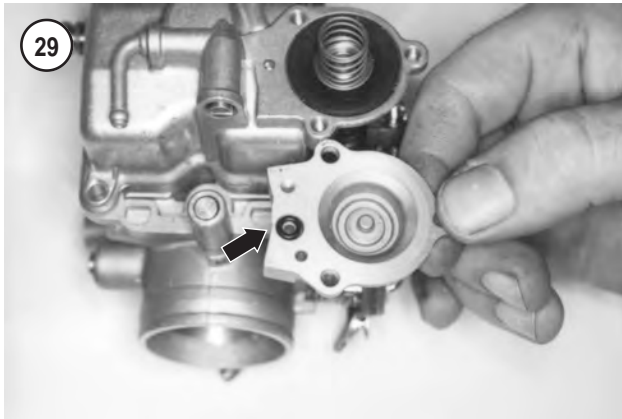

1. Clean all metal parts in carburetor cleaner. Follow the manufacturer's instructions.
2. Remove all parts from the cleaner and blow dry with compressed air. Blow out the jets (**Figure 32**) with compressed air. Do not use a piece of wire or small drill bit to clean them, as minor gouges in a jet can alter the flow rate and upset the air/fuel mixture.
3. Make sure the needle jet holder (**Figure 32**) bleed tube orifices are clear.
4. Make sure all fuel and air openings are clear. Blow them out with compressed air if necessary.
5. Check the float assembly for leaks; see A, **Figure 33** (1988-1991 models) or **Figure 34** (1992-2003 models). Place the float in a container full of water and push it down. It should float and there should be no bubbles. Replace the float assembly if it leaks.
6. Check the float needle (B, **Figure 33**) and seat (**Figure 35**) contact areas closely. Both contact surfaces should be smooth with no gouging or other damage. Replace the needle if damaged. The seat is a permanent part of the carburetor housing; if damaged, replace the housing.
7. A damaged accelerator pump diaphragm (**Figure 36**) will cause poor acceleration. Hold the diaphragm up to a strong light and check the diaphragm for pin holes, cracks or other damage. Replace if necessary.

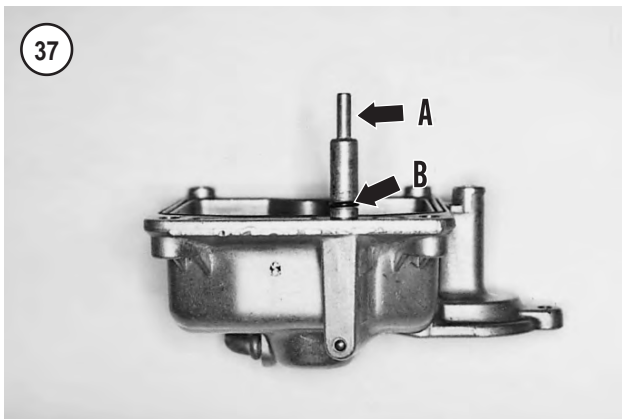

8. Remove the accelerator pump nozzle (A, **Figure 37**) and O-ring (B) from the float bowl. Clean the nozzle with compressed air.

9. Replace the pump rod if bent or worn.

10. Inspect all O-rings and replace if necessary. When replacing an O-ring, make sure the new O-ring fits in its groove properly. See **Figure 38**, typical.

11. Inspect the pilot jet (**Figure 32**) for wear or damage. Check the slot in the top of the jet for cracks or breaks. Replace if damaged.

12. Inspect the vacuum piston (**Figure 39**) as follows:

- a. Check the spring (**Figure 25**) for fatigue, stretching, distortion or other damage.
- b. Check the vacuum passage through the bottom of the piston for contamination. Clean passage if blocked.
- c. The sides of the piston ride in grooves machined in the carburetor bore. Check these sides for roughness, nicks, cracks or distortion. If the piston sides are damaged, check the mating grooves in the carburetor for damage. Minor roughness can be removed with emery cloth or by buffing. If the sides are severely damaged, replace the vacuum piston.
- d. Hold the vacuum piston up to a light and check the diaphragm (**Figure 40**) for holes, tearing, cracks, age deterioration or other damage. Check the diaphragm where it is mounted against the piston. If the diaphragm is damaged, replace the vacuum piston.

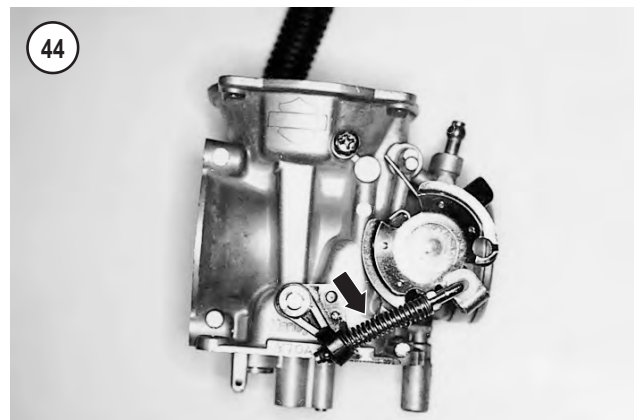
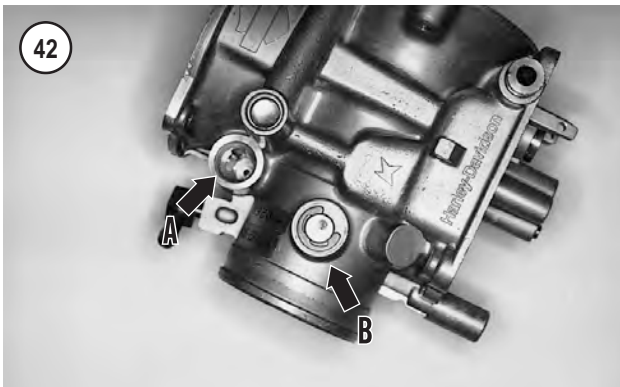
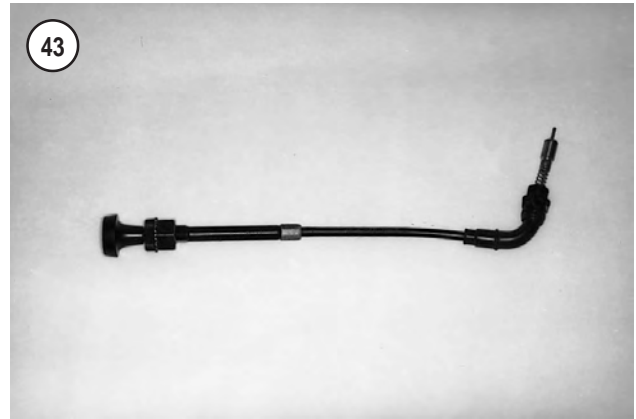

e. Check the jet needle (B, **Figure 27**) for bending or damage.

13. Inspect the enricher system as follows:

- a. Check for a rough or damaged enricher valve. Check the needle (**Figure 41**) on the end of the enricher valve for bending or contamination.
- b. Check the enricher valve spring for fatigue, stretching or distortion.
- c. The enricher valve chamber (A, **Figure 42**) in the carburetor must be clean. Clean the chamber, making sure the enricher valve air inlet and the air/fuel passages are clear.
- d. Check the enricher valve cable (**Figure 43**) for kinks or other damage.

14. Check the throttle rod (**Figure 44**) and all external carburetor components for missing or damaged parts.

15. Check that the throttle valve shaft E-clip (B, **Figure 42**) is properly secured in the groove on the end of the shaft.

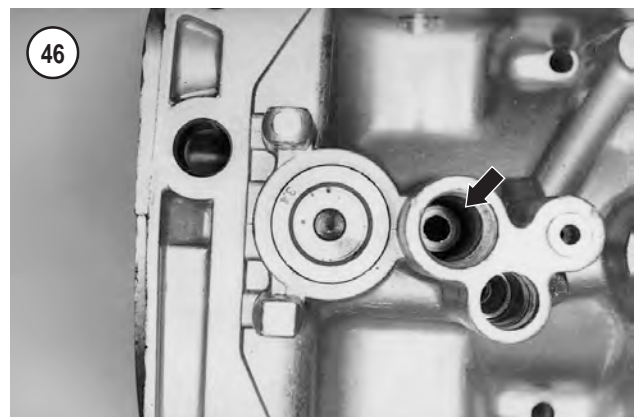
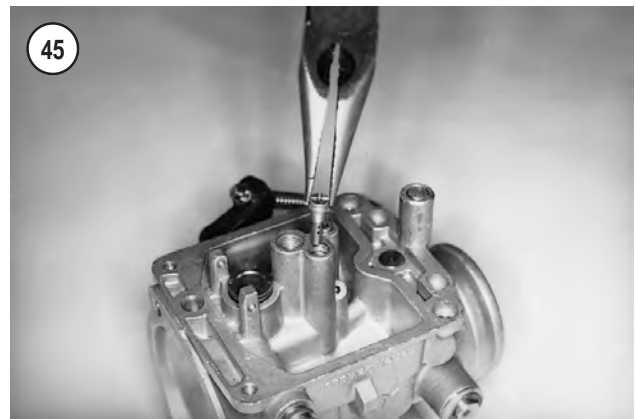

Assembly

Refer to **Figure 9**.

1. Prior to assembly, refer to *Inspection* in this section. Clean all parts before assembly.

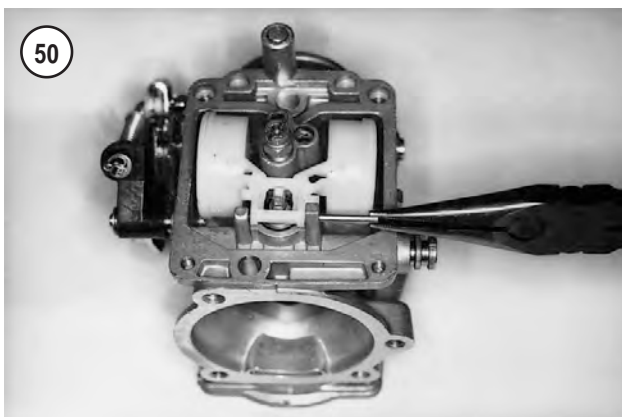
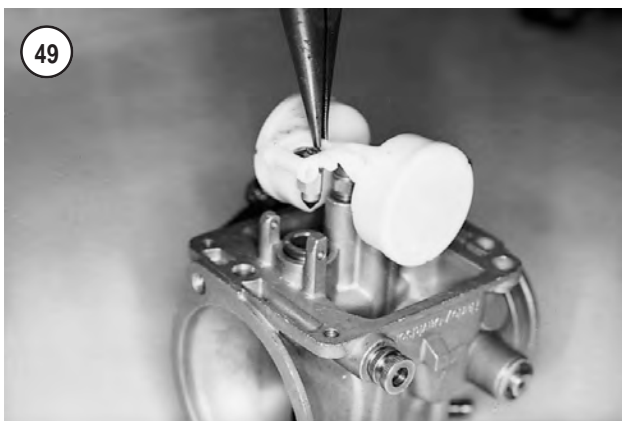
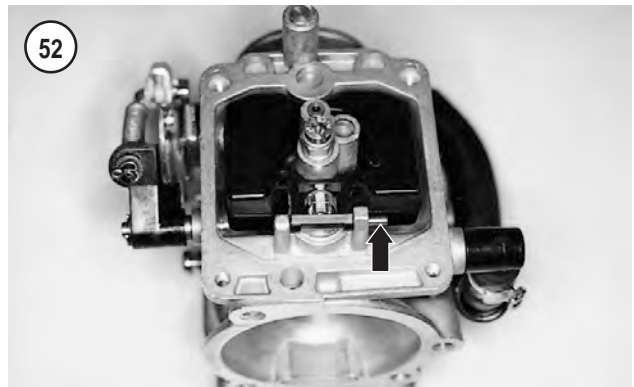
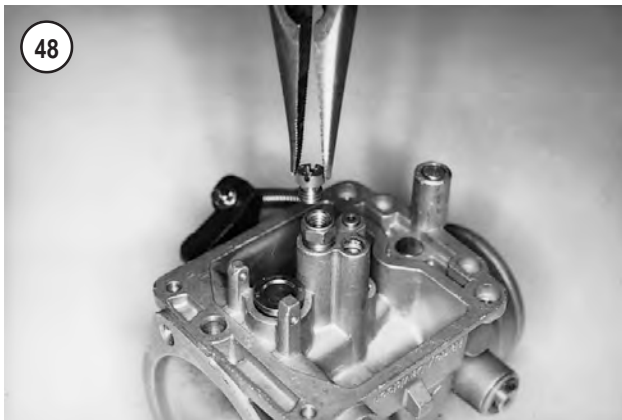
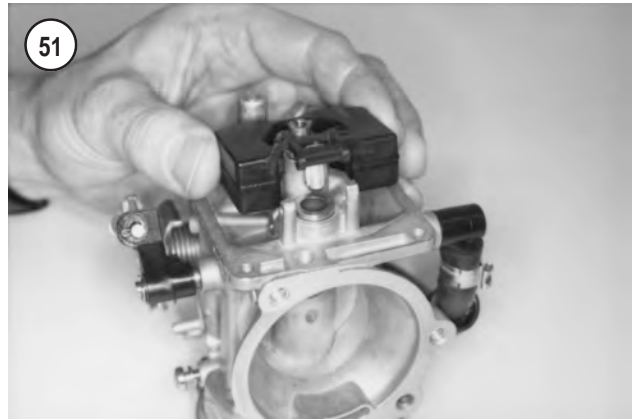
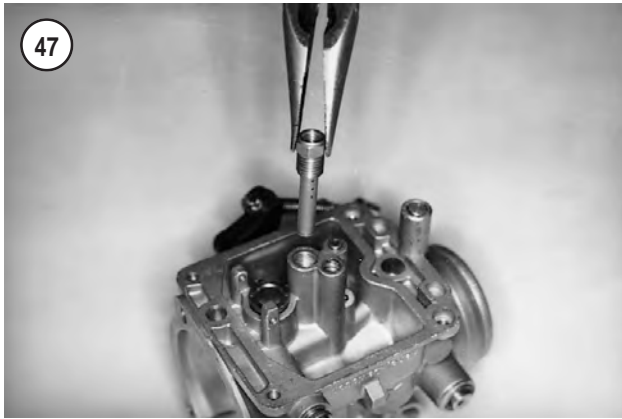

NOTE

*Before installing new jets, check the jet size and compare it to the old jet. Refer to **Table 1** for original equipment jet sizes.*

2. Place the pilot jet (**Figure 45**) into the passage and tighten it with the same screwdriver used during removal.
3. The needle jet has two different sides and can be installed incorrectly. Install the needle jet into its passage (**Figure 46**) so that the end with the larger opening faces up toward the vacuum piston chamber.
4. Install the needle jet holder (**Figure 47**) into the main jet passage and tighten it securely.
5. Install the main jet (**Figure 48**) onto the end of the needle jet holder and tighten securely.
- 6A. On 1988-1991 models, install the float as follows:
 - a. Install the fuel valve onto the float (**Figure 49**) and position the float onto the carburetor so the valve drops into its seat.
 - b. Align the float pivot arm with the two carburetor mounting posts and slip the pin through the float pivot arm and mounting posts (**Figure 50**).
- 6B. On 1992-2003 models, install the float as follows:
 - a. Install the fuel valve onto the float (**Figure 51**) and position the float onto the carburetor so that the valve drops into its seat.
 - b. Align the float pivot arm with the two carburetor mounting posts and slip the pin through the float pivot arm and mounting posts (**Figure 52**).

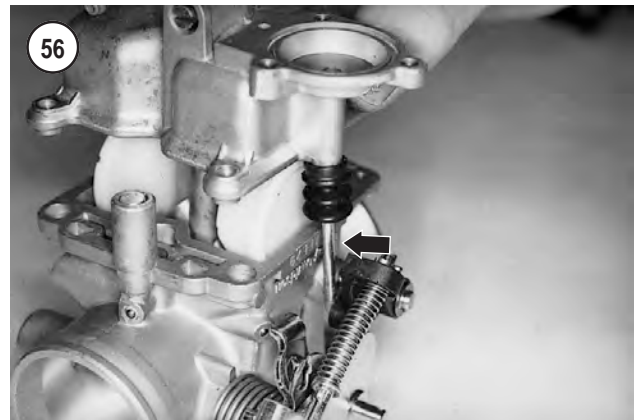
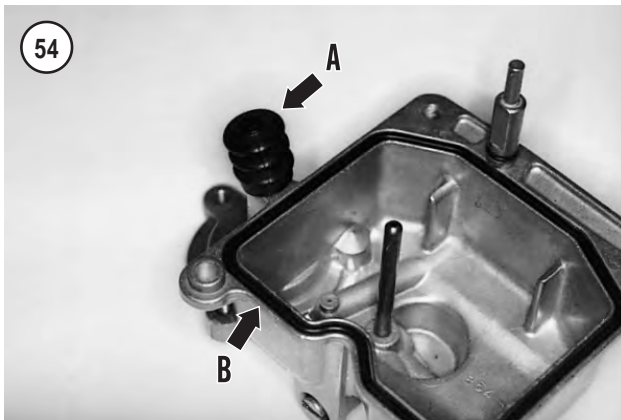
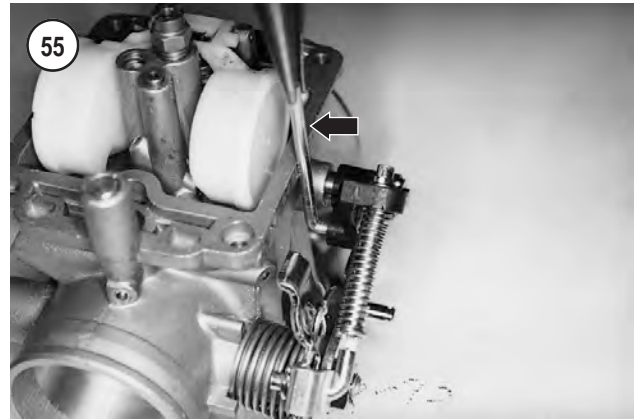
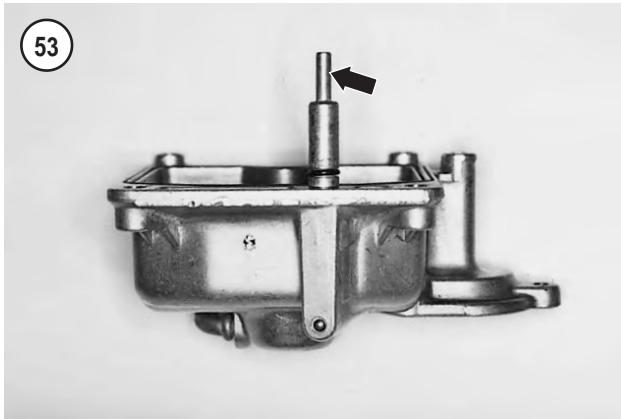

7. Check float level as described in this section.

8A. On 1988 models, assemble and install the float bowl using the following procedure:

- a. Install a new O-ring onto the float bowl.
- b. Install the float bowl onto the carburetor.
- c. Install the retaining screws and lockwashers. Tighten the screws securely in a crisscross pattern.

8B. On 1989-2003 models, assemble and install the float bowl using the following procedure:

- a. Insert the accelerator pump nozzle into the float bowl. Install the O-ring onto the nozzle. See **Figure 53**.
- b. Install the rubber boot (A, **Figure 54**) and O-ring (B) onto the float bowl.
- c. Connect the pump rod onto the lever assembly on the carburetor (**Figure 55**).
- d. Insert the pump rod through the boot on the float bowl while installing the float bowl (**Figure 56**) onto the carburetor. Then check that the pump rod is still attached to the lever assembly as shown in **Figure 57**. Check also to see if the pump rod is visible through the hole in the pump chamber in the float bowl (**Figure 58**). If not, remove and reinstall the float bowl and pump rod.
- e. Install the float bowl screws and washers and tighten securely in a crisscross pattern.

9. On 1989-2003 models, install the accelerator pump diaphragm assembly using the following procedure:



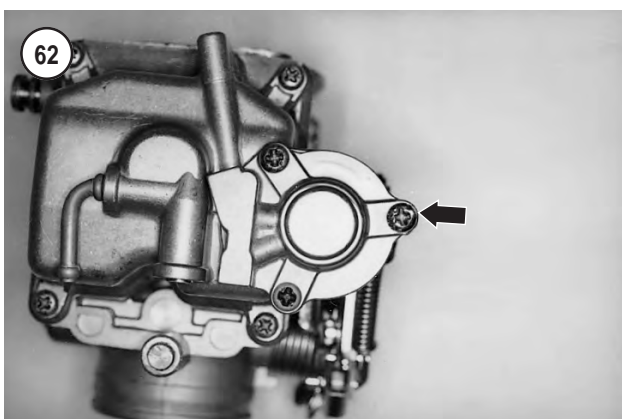
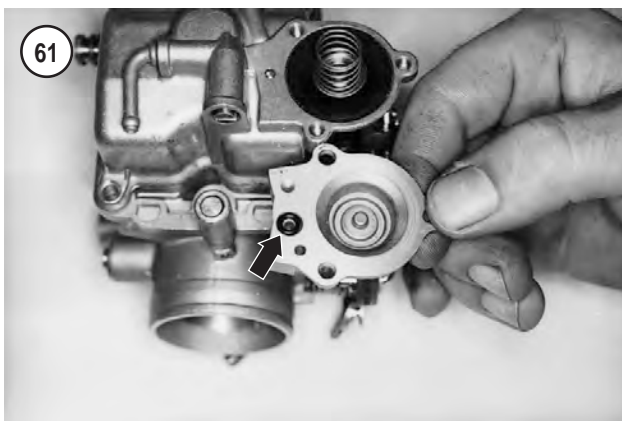
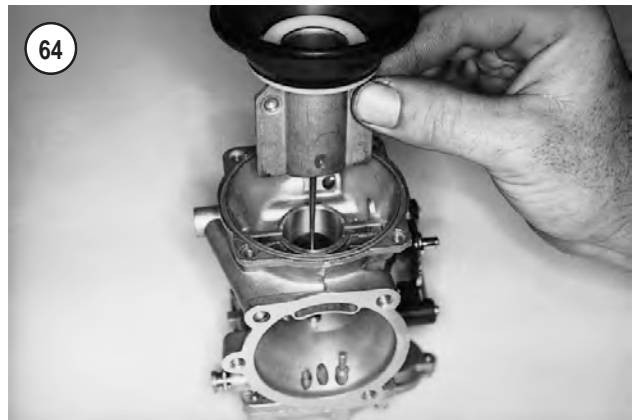
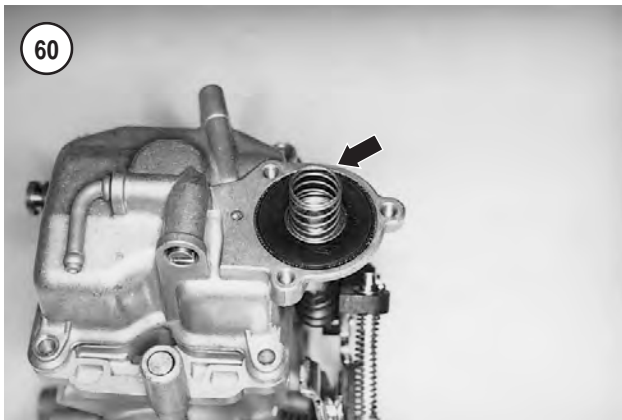
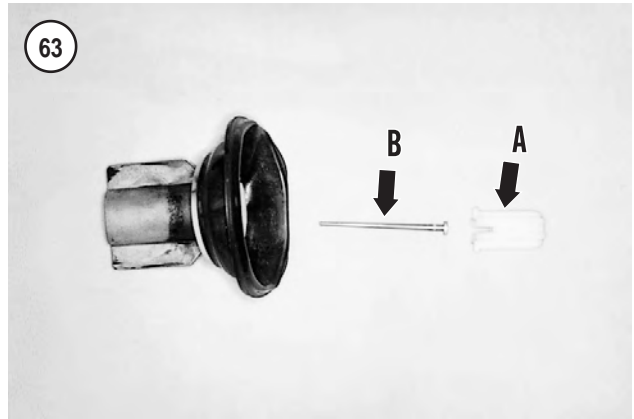
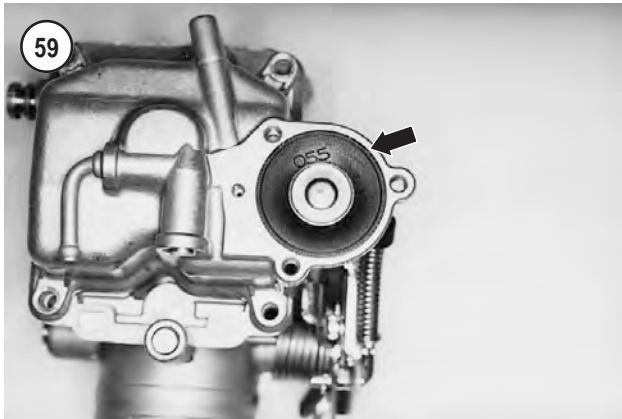

- a. Insert the accelerator pump diaphragm into the bottom of the float bowl. Make sure the diaphragm (**Figure 59**) seats around the bowl groove evenly.
- b. Install the spring (**Figure 60**) into the center of the accelerator pump diaphragm.
- c. Install the O-ring (**Figure 61**) into the cover passage-way hole.
- d. Align the cover assembly with the diaphragm and bowl and install the cover assembly. Install the screws (**Figure 62**) and lockwashers and tighten securely.

10. Insert the jet needle (B, **Figure 63**) through the center hole in the vacuum piston. Place the spring seat (A, **Figure 63**) over the top of the needle to secure it.

11. Align the slides on the vacuum piston with the grooves in the carburetor bore and install the vacuum piston (**Figure 64**). The slides on the piston are offset, so the piston can only be installed one way. When installing the vacuum piston, make sure the jet needle enters the needle jet.

12. Seat the outer edge of the vacuum piston into the groove at the top of the carburetor piston chamber.

13. Insert the spring (**Figure 65**) into the vacuum piston so that the end of the spring fits over the spring seat.

14. Align the free end of the spring with the carburetor top and install the top onto the carburetor, compressing the spring.

15. Hold the carburetor top in place and lift the vacuum piston with a finger. The piston should move smoothly. If



the piston movement is rough or sluggish, the spring may be improperly installed. Remove the top and reinstall the spring.

16. Install the top carburetor screws, lockwashers and flat washers securely.

17. Install the throttle cable bracket (A, **Figure 66**) onto the carburetor so that the end of the idle speed screw engages the top of the throttle cam stop (B). Hold the bracket in place and install the bracket's side mounting screw and washer; tighten the screw securely. Then install the upper bracket mounting screw (**Figure 67**), lockwasher and flat washer finger-tight. Tighten the remaining carburetor cap screw securely.

18. Align the enricher valve needle (**Figure 68**) with the needle passage in the carburetor and install the enricher valve. Tighten the valve nut securely.

19. Install the float bowl overflow hose and secure it with the clamp.

Float Level Adjustment

1988-1991 models

An incorrect float level can cause flooding as well as poor fuel economy and acceleration.

The carburetor must be removed and partially disassembled for this adjustment.

1. Remove the carburetor as described in this section.
2. Remove the float bowl as described in *Disassembly* in this section.
3. One-piece floats are used in the carburetor. Before checking the float level, check that both float halves (**Figure 69**) are aligned at an equal height with each other. If the float halves are not in alignment, remove the float and check it for damage.
4. Turn the carburetor to position the float bowl as shown in **Figure 70**. Measure the float height from the face of the bowl mounting flange surface to the bottom float surface. Do not apply pressure to the float when measuring. The correct float height is 0.725-0.730 in. (18.4-18.5 mm).

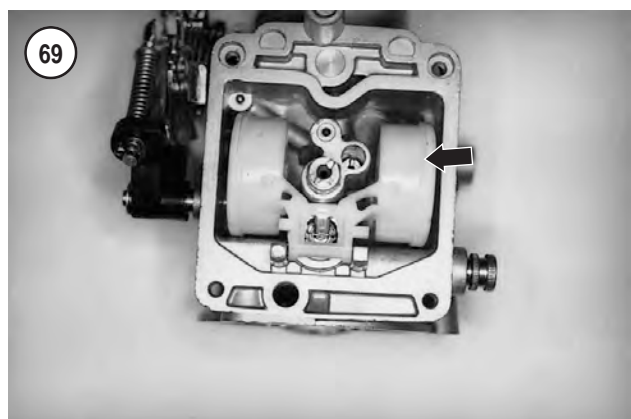
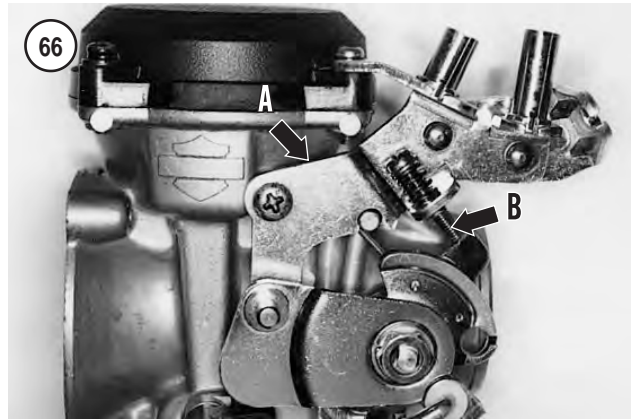

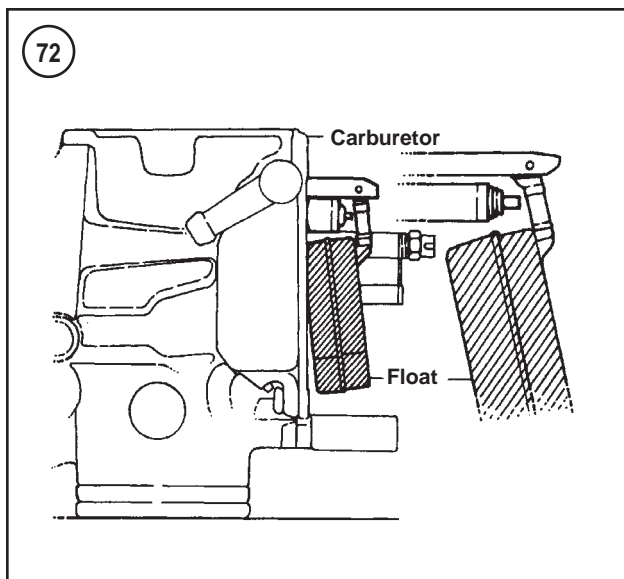
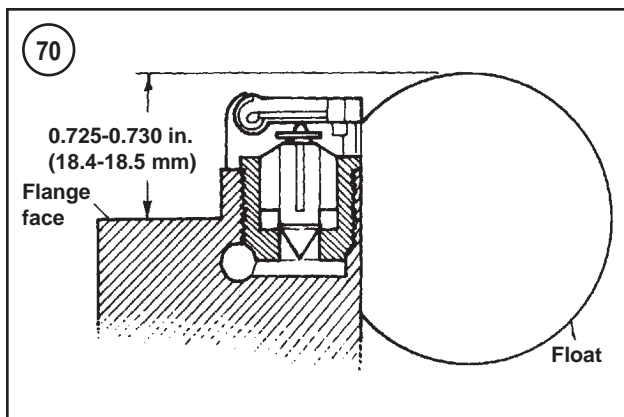

5. If the float level is incorrect, remove the float pin and float. Bend the tab on the float hinge that contacts the fuel valve.
6. Reinstall the float and the float pin and recheck the float level. Repeat until the float level is correct.
7. Reinstall the float bowl as described in *Assembly* in this section.
8. Reinstall the carburetor as described in this chapter

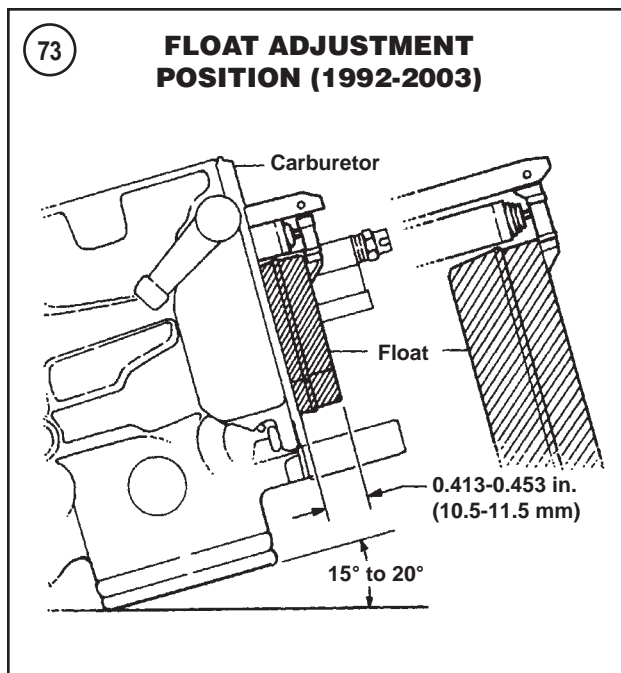

1992-2003 models

An incorrect float level can cause flooding as well as poor fuel economy and acceleration.

The carburetor must be removed and partially disassembled for this adjustment.

1. Remove the carburetor as described in this chapter.
2. Remove the float bowl as described in *Disassembly* in this chapter.
3. One-piece floats are used in the carburetor. Before checking the float level, check that both float halves (**Figure 71**) are aligned at an equal height with each other. If the float halves are not in alignment, remove the float and check it for damage.
4. Place the carburetor intake spigot on a flat surface as shown in **Figure 72**. This is the measuring position.
5. Tilt the carburetor 15-20° as shown in **Figure 73**. At this position, the float tab will contact the fuel valve pin without compressing the internal fuel valve spring.

NOTE

If the carburetor is tilted less than 15° or more than 20°, the following carburetor measurements will be incorrect.

6. Measure from the carburetor flange surface to the top of the float as shown in **Figure 73**. When measuring float level, do not compress the fuel valve internal spring. The correct float level measurement is 0.413-0.453 in. (10.5-11.5 mm).
7. If the float level is incorrect, remove the float pin and float. Bend the tab on the float hinge that contacts the fuel valve.
8. Reinstall the float and the float pin and recheck the float level. Repeat until the float level is correct.

9. Reinstall the float bowl as described in *Assembly* in this section.
10. Reinstall the carburetor as described in this chapter.

INTAKE MANIFOLD

Removal/Installation

1988-1989 models

Refer to **Figure 74**.

A rubber intake manifold is used on these models. A hose clamp secures the carburetor spigot in the manifold.

1. Remove the carburetor as described in this chapter.

NOTE

It may be necessary to use a ball-end type or shortened Allen wrench for access to the intake manifold bolts.

2. Remove the bolts and nuts securing the intake manifold to the cylinder heads.

NOTE

*The front and rear intake manifold flanges are different. If the flanges are not marked (**Figure 75**), label them with an F (front) and R (rear) so they will be reinstalled in the correct location.*

3. Remove the intake manifold, flanges and manifold seals.
4. Inspect the intake manifold.
5. Inspect the intake manifold seals (A, **Figure 76**) for wear, deterioration or other damage. If damaged, replace the seals as a set.
6. Install the flanges and seals onto the intake manifold. Note that the seals (A, **Figure 76**) and flanges (B) have a tapered side. Fit the seal taper into the flange taper. Be sure the correct flange (F or R) is located at the front or rear of the manifold.
- 7A. Early 1988 models are not equipped with molded bosses on the intake manifold. On those models, position the manifold so the parting line is 1/8 in. (3.2 mm) past the cast boss on each flange.
- 7B. On late 1988-1989 models, align the molded boss on each tube of the intake manifold with the cast boss on each flange (**Figure 77**).
8. Install the intake manifold onto the cylinder head intake ports. The slotted ends of the flanges must point to the left.
9. Make sure the front and rear seals seat squarely against the cylinder head mating surfaces.

CAUTION

Do not attempt to align the intake manifold after tightening the bolts. This will damage the manifold seals.

10. Install the intake manifold mounting bolts and nuts. Tighten the bolts and nuts to 72-120 in.-lb. (8-14 N•m).

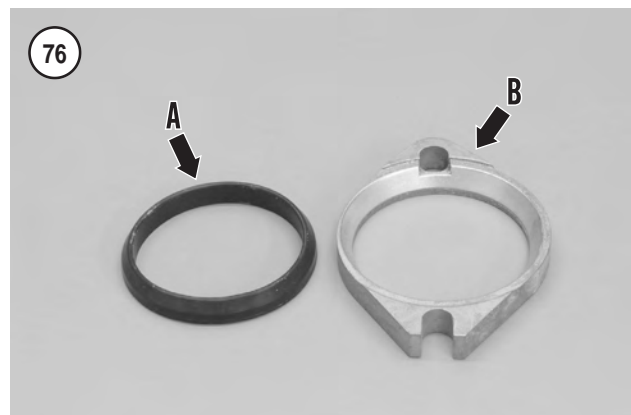
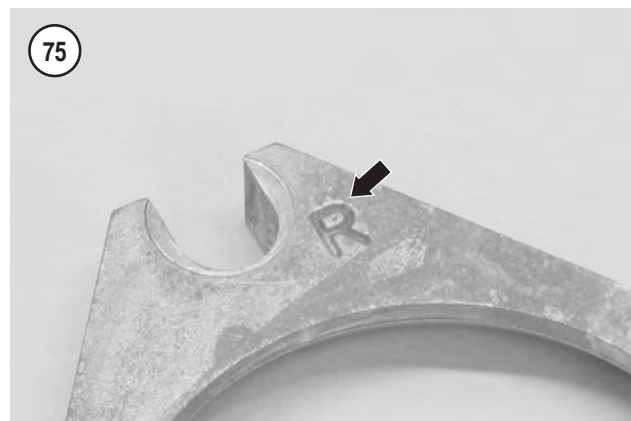
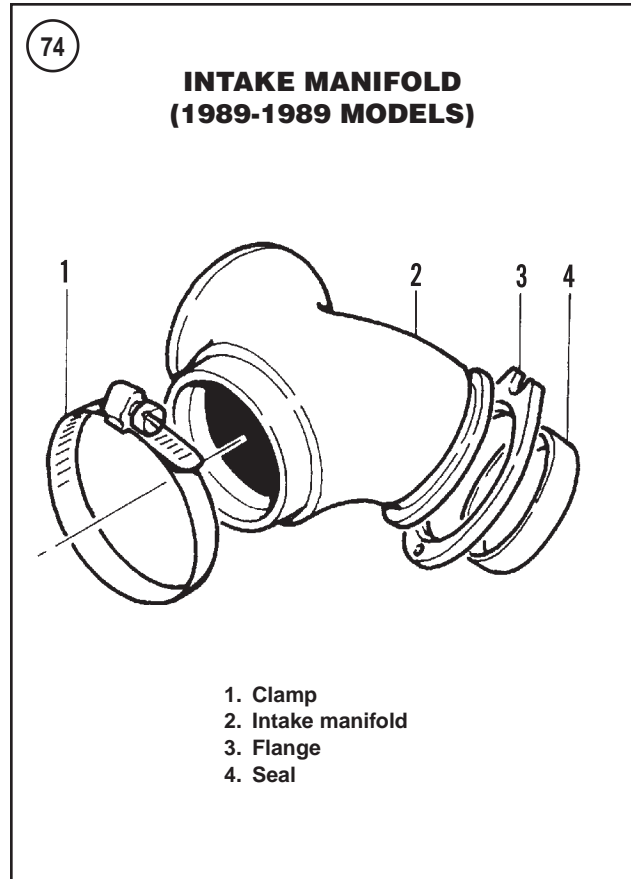

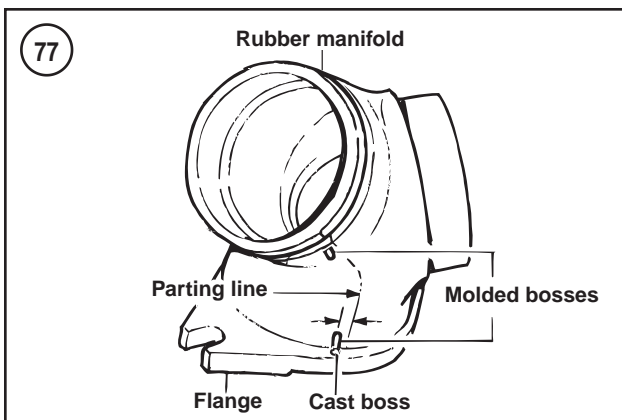

11. Install the carburetor as described in this chapter.

1990-2003 models

Refer to **Figure 78**.

An aluminum intake manifold is used on these models. The air filter backplate secures the carburetor in the manifold.

1. Remove the carburetor as described in this chapter.

NOTE

It may be necessary to use a ball-end type or shortened Allen wrench for access to the intake manifold bolts.

NOTE

On 1990 models the left side of the intake manifold is secured by studs and nuts. On later models, Allen bolts secure both sides of each manifold flange.

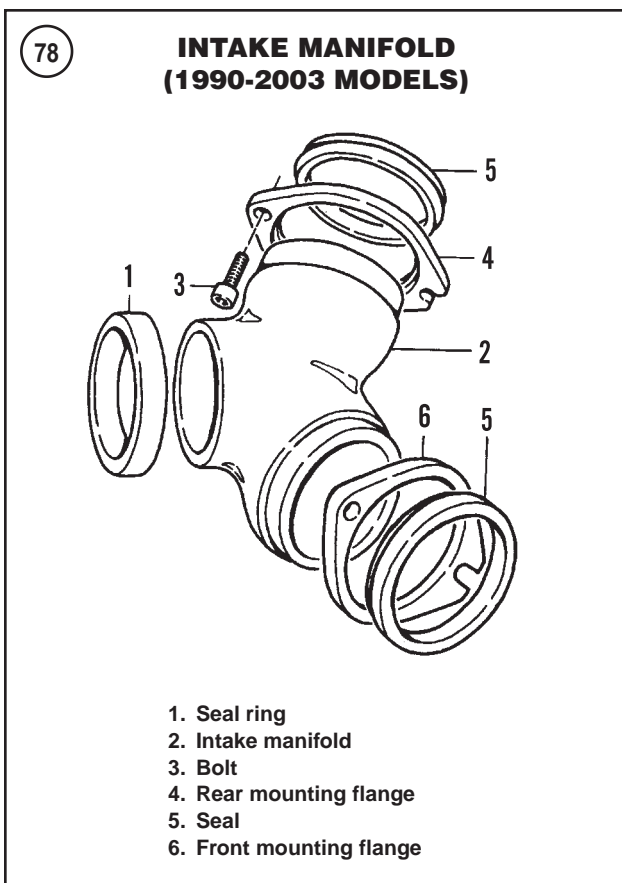

2. Remove the bolts (A, **Figure 79**) and, if used, nuts securing the intake manifold (B) to the cylinder heads.

NOTE

*The front and rear intake manifold flanges are different. If the flanges are not marked (**Figure 76**), label them with an F (front) and R (rear) so they will be reinstalled in the correct location.*

3. Remove the intake manifold, flanges and manifold seals.
4. Inspect the intake manifold.
5. Inspect the intake manifold seals (A, **Figure 76**) for wear, deterioration or other damage. If damaged, replace the seals as a set.
6. Install the flanges and seals onto the intake manifold. Note that the seals (A, **Figure 76**) and flanges (B) have a tapered side. Fit the seal taper into the flange taper. Be sure the correct flange (F or R) is located at the front or rear of the manifold.
7. Install the intake manifold onto the cylinder head intake ports. The slotted ends of the flanges must point to the left.
8. Make sure the front and rear seals seat squarely against the cylinder head mating surfaces.
9. Tighten the intake manifold fasteners finger-tight.
10. Install the carburetor as described in this chapter.
11. Install the air filter backplate and air filter as described in this chapter.
12. Tighten the intake manifold fasteners to 72-120 in.-lb. (8-14 N•m).

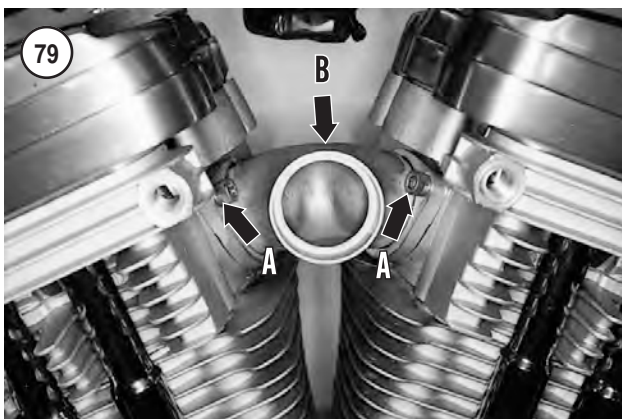

FUEL HOSE AND CLAMPS

CAUTION

Discard removed crimp-type hose clamps. Do not reuse removed clamps. The clamping ability of the clamp is destroyed during removal.

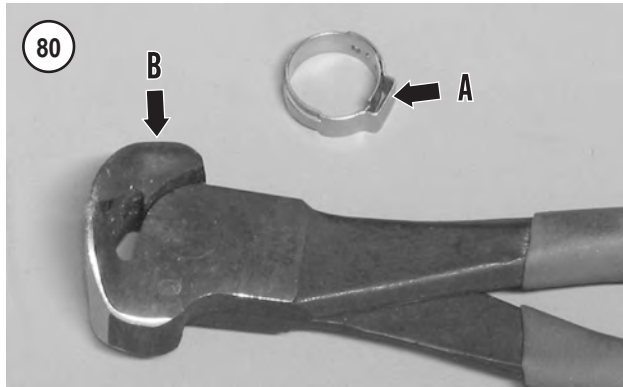

The fuel supply hose between the fuel valve and carburetor is secured at the hose ends with non-reusable hose clamps (A, **Figure 80**). Use diagonal pliers or other suitable tool to separate the clamp bands, then remove the clamp. Use hose clamp pliers (part No. HD-97087-65B or equivalent) to compress the clamp bands during installation. A screw-type hose clamp may be substituted in place of the crimp-type hose clamp.

NOTE

*End cutting pliers (B, **Figure 80**) may be modified to compress the band clamps. Make sure to test the performance of the tool by checking the fit and integrity of the installed clamp.*

THROTTLE AND IDLE CABLES

Removal/Installation

Refer to **Figure 81**.

1. Remove the air filter backplate as described in this chapter.
2. Before removing the cables, compare the routing of both cables with the routing path shown in **Figure 82**. If necessary, make a diagram of the routing path for reassembly.
3. Slide the rubber boot (**Figure 83**) on each cable away from each cable adjuster.
4. Loosen the cable adjusting nuts and turn the cable adjusters (A and B, **Figure 84**) to obtain as much cable slack as possible.
5. Remove the screws securing the upper and lower right switch/throttle housing (**Figure 85**) together. Separate the housing from the handlebar.
6. Loosen the cable locknuts at the lower switch housing.
7. Unhook the cables from the throttle grip and remove the ferrule from the end of each cable.
8. Unscrew each cable and remove it from the lower housing assembly.
9. At the carburetor, hold the lever up with one hand and disengage the cable end. Slip the cable out through the carburetor bracket. Repeat for the other cable. **Figure 86** shows the throttle cables with the carburetor removed for clarity.

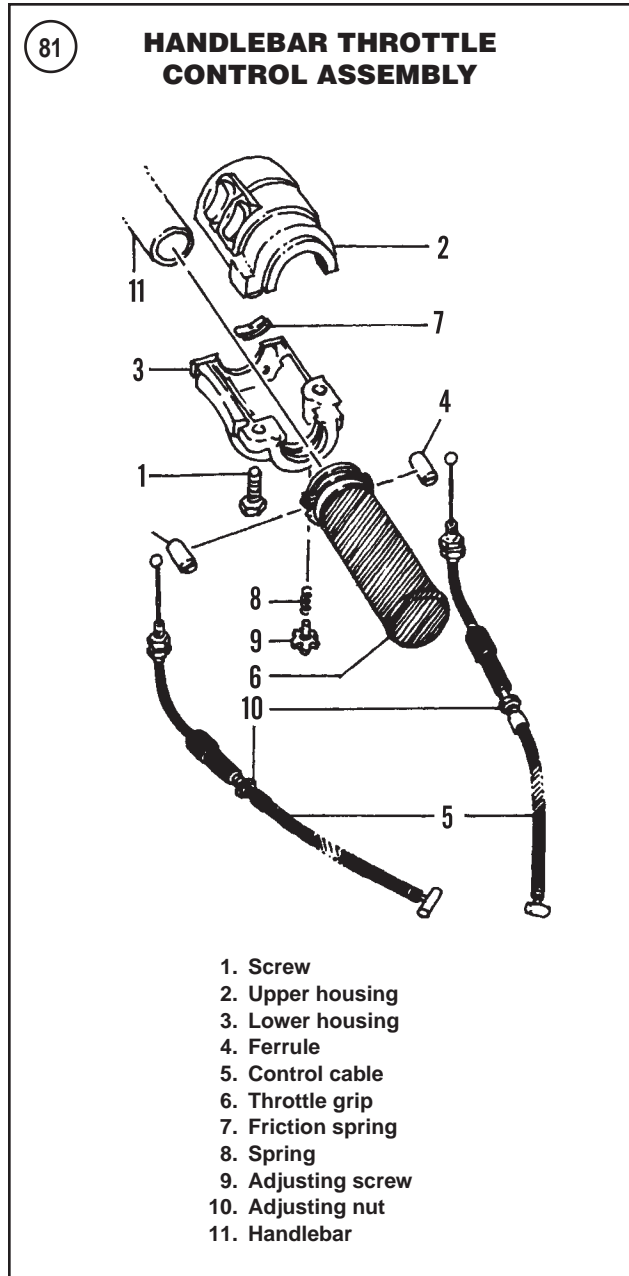

10. Pass both cables through the retaining clip. On 1989-1994 models, the clip is on the fuel tank mounting bolt (**Figure 87**). On 1995-2003 models, it is on the ignition switch.

11. Remove the cables from the motorcycle.

12. Clean the throttle grip in solvent and dry thoroughly. Check the throttle cable slots for cracks or other damage. Replace the throttle grip if necessary.

13. The friction adjust screw is secured to the lower switch housing with a circlip. If necessary, remove the friction spring, circlip, spring and friction adjust screw. Check these parts for wear or damage. Replace damaged parts. Reverse removal to install. Make sure the circlip seats in the friction screw groove completely.

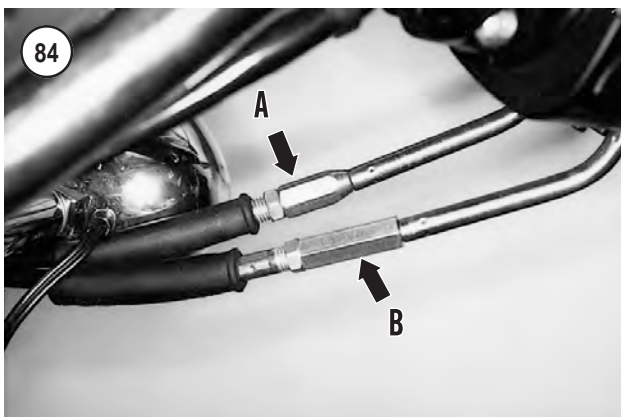
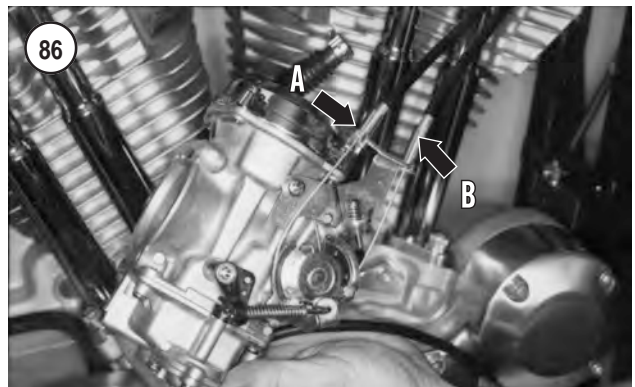
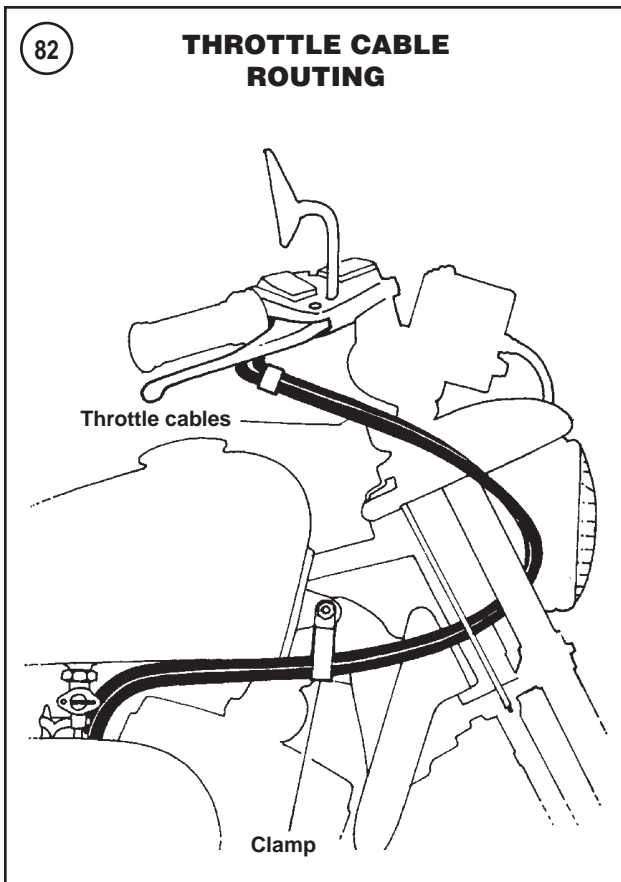

14. Clean the throttle area on the handlebar with solvent or electrical contact cleaner.

15. Lightly wipe the throttle area on the handlebar with graphite.

NOTE

The throttle cable (A, Figure 84) uses a 5/16-18 in. threaded cable adjuster.

16. Screw the throttle cable into the lower switch housing and fit the ferrule onto the end of the cable. Then insert the ferrule into the right anchor slot at the top of the throttle.

NOTE

The idle cable (B, Figure 84) uses a 1/4-20 in. threaded cable adjuster.

17. Screw the idle cable into the lower switch housing and fit the ferrule onto the end of the cable. Then insert the ferrule into the left anchor slot at the top of the throttle.

18. Assemble the upper and lower switch housings and slide the throttle grip onto the handlebar. Install the housing screws and tighten securely. Operate the throttle and make sure both cables move in and out properly.

19. Route the throttle cables from the throttle grip to the carburetor as shown in **Figure 82** or as noted during removal. Pass both cables through the retaining clip (**Figure 87**).

20. Install the throttle cable (A, **Figure 84**) into the shorter, outboard cable guide on the carburetor bracket; see A, **Figure 86**.

21. Install the idle cable (B, **Figure 84**) into the longer, in-board cable guide on the carburetor bracket; see B, **Figure 86**.

22. Operate the throttle grip and make sure the carburetor throttle linkage is operating correctly and with no binding. If operation is incorrect or there is binding, carefully check that the cables are attached correctly and there are no tight bends in the cables.

WARNING

Do not ride the motorcycle until the throttle cables are properly adjusted.

23. Adjust the throttle and idle cables as described in Chapter Three.

24. Start the engine and allow it to idle in neutral. Then turn the handlebar from side-to-side. Do not operate the throttle. If the engine speed increases as the handlebar assembly is turned, the throttle cables are routed incorrectly. Recheck cable routing and adjustment.

STARTING ENRICHMENT VALVE (CHOKE) CABLE REPLACEMENT

Removal/Installation

1. Remove the air filter backplate as described in this chapter.
2. Remove the enricher bracket mounting screw (**Figure 88**) and allow the bracket to rest on top of the intake manifold.
3. Unscrew the enricher from the carburetor. **Figure 89** shows the enricher cable with the carburetor removed from the motorcycle for clarity.
4. Remove the enricher cable (**Figure 90**) from the motorcycle.
5. Remove the bracket from the enricher cable.
6. Reverse the removal steps to install the enricher cable while noting the following:
 - a. Align the enricher valve needle (**Figure 91**) with the needle passage in the carburetor and install the enricher valve. Tighten the valve nut securely.
 - b. Adjust the enricher cable as described in Chapter Three.



FUEL TANK

The fuel tank is bolted to the upper frame tube. A 3-way fuel shutoff valve is mounted on the bottom of the tank on the right side.

Depending on model year and state, fuel tank venting is as follows:

1. On 1988-1991 non-California models, the filler cap is equipped with a pressure/vacuum relief valve for fuel tank venting.
2. On 1991 California models, refer to *Evaporative Emission Control System* in this chapter for fuel tank venting information.
3. On 1992-2003 models, the fuel tank is vented through a standpipe installed inside the fuel tank. A hose is connected

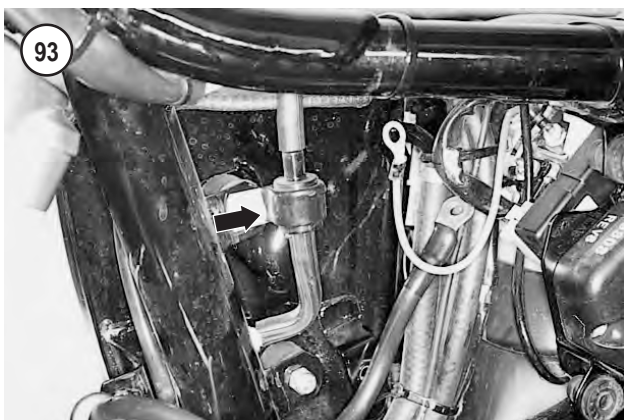
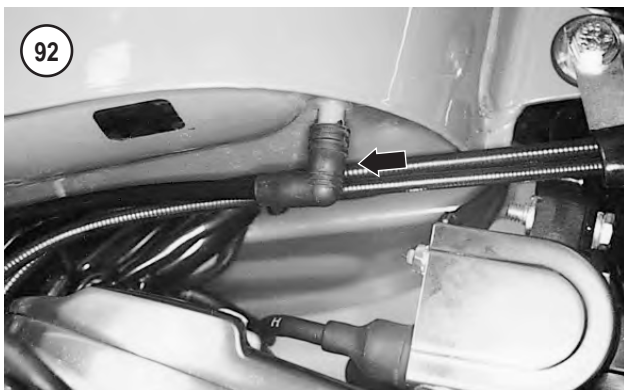

to the standpipe nozzle (**Figure 92**) at the bottom of the tank. This tube is routed along the frame and connected to a vapor valve (**Figure 93**) mounted to the frame and located between the battery and oil tank.

- a. On non-California models, a hose connected to the bottom of the vapor valve connects to a fitting in the hollow frame member.
- b. On California models, a hose connected to the bottom of the vapor valve connects to the carbon canister.

Removal/Installation

WARNING

Some fuel may spill from the fuel tank hose during this procedure. Because gasoline is

extremely flammable and explosive, perform this procedure away from all open flames, including appliance pilot lights, and sparks. Do not smoke or allow anyone to smoke in the work area, as an explosion and fire may occur. Always work in a well-ventilated area. Wipe up any spills immediately.

WARNING

Make sure the fuel tank vapor hoses are routed in such a way that they cannot contact any hot engine or exhaust component. These hoses contain flammable vapors.

CAUTION

When removing the fuel tank in the following procedure, keep track of all fasteners and rubber bushings so they may be installed into their original mounting positions. Incorrect fastener assembly can cause tank damage.

Refer to **Figure 94** or **Figure 95**.

1. Disconnect the negative battery cable (Chapter Twelve).
- 2A. On 1988-1994 models, drain the fuel tank as follows:
 - a. Turn the shutoff valve to off.
 - b. Disconnect the fuel supply hose (**Figure 96**) from the fuel shutoff valve.
 - c. Connect a longer hose to the shutoff valve fitting and place the open end of the hose into a gas can.
 - d. Turn the shutoff valve to reserve and drain the fuel into the tank. Account for the fuel line insulator.
- 2B. On 1995-2003 models, drain the fuel tank as follows:

NOTE

A vacuum-operated fuel valve is installed on all models. A hand-operated vacuum pump is required to drain the fuel tank.

- a. Turn the shutoff valve to off.
- b. Connect the drain hose to the fuel valve and secure it with a hose clamp. Insert the end of the drain hose into a gas can.
- c. Disconnect the vacuum hose from the fuel valve.
- d. Connect a hand-operated vacuum pump to the fuel valve vacuum hose fitting.
- e. Turn the fuel valve to the reverse position.

CAUTION

Do not apply more vacuum than 25 in. (635 mm) Hg or the fuel valve diaphragm will be damaged.

- f. Operate the vacuum pump handle and apply a maximum of 25 in. (635 mm) Hg of vacuum. Once the vacuum is applied, the fuel will start to flow into the gas can.
- g. When fuel stops flowing through the hose, turn the fuel valve off and release the vacuum. Disconnect the vacuum pump and drain hose.

94

FUEL TANK (1988-1992 MODELS)

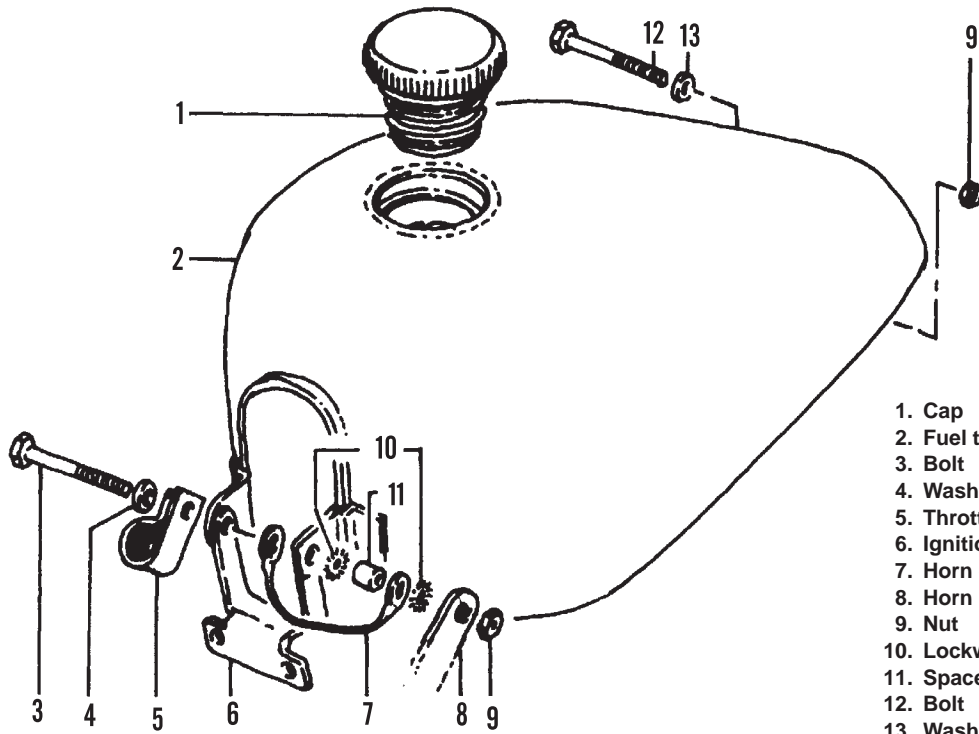

- 1. Cap
- 2. Fuel tank
- 3. Bolt
- 4. Washer
- 5. Throttle cable clip
- 6. Ignition coil bracket
- 7. Horn ground wire (883 models)
- 8. Horn bracket (883 models)
- 9. Nut
- 10. Lockwasher (early 883 models)
- 11. Spacer (883 models)
- 12. Bolt
- 13. Washer

95

FUEL TANK (1993-2003 MODELS)

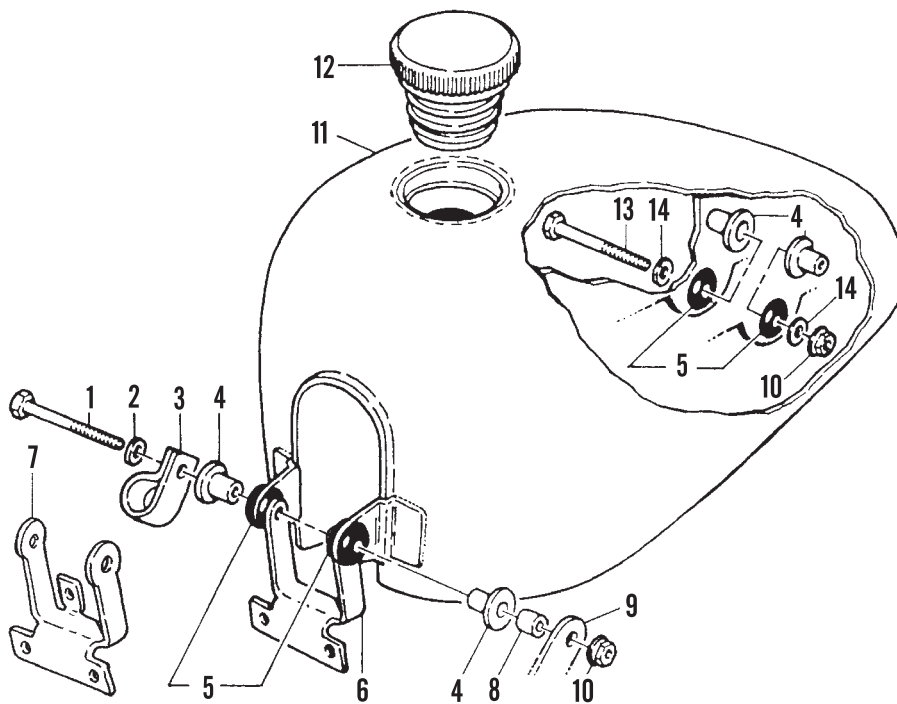

- 1. Bolt
- 2. Washer
- 3. Clamp (1993-1994 models)
- 4. Spacer flange
- 5. Rubber grommet
- 6. Ignition coil bracket (1993-1994 models)
- 7. Ignition coil bracket (1995-2003 models)
- 8. Spacer (1993-1996 models)
- 9. Horn bracket (1993-1996 models)
- 10. Locknut
- 11. Fuel tank
- 12. Filler cap and gasket
- 13. Bolt
- 14. Washer



3. Remove the front (Figure 97) and rear (Figure 98) fuel tank mounting fasteners.
4. Disconnect the vapor vent hose from the fitting on the bottom of the fuel tank (Figure 92), if so equipped.
5. Remove the fuel tank.

WARNING

Store the fuel tank in a safe place, away from open flame.

6. Drain any remaining fuel left in the tank into a gas can.
7. Installation is the reverse of removal. Note the following:
 - a. Tighten the front and rear bolts to the tightening torque specified in Table 2.

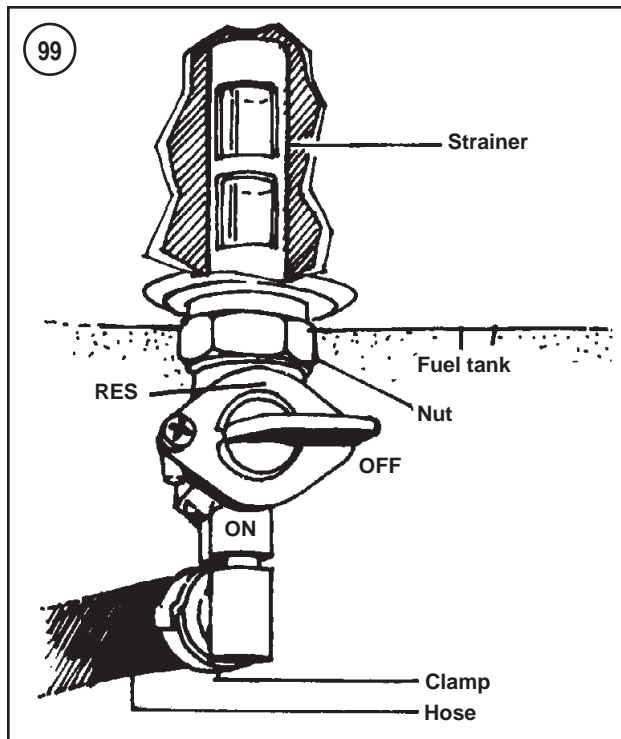

- b. On all 883 models, make sure the horn does not contact the frame or ignition coil bracket.
- c. Reconnect the fuel hose (Figure 96) to the fuel valve and secure it with a new hose clamp as described in Fuel Hose And Clamps in this chapter.
- d. Refill the tank and check for leaks.

Inspection

Refer to Figure 94 or Figure 95.

1. Inspect all of the fuel and vent lines for cracks, age deterioration or damage. Replace damaged lines with the same type and size materials.
2. Check the fuel line insulator for damage.
3. Check for damaged or missing rubber dampers.
4. Remove the filler cap and inspect the inside of the tank for rust or contamination. If there is a rust buildup inside the tank, remove it as described in this chapter and flush the tank to remove all rust and debris.
5. Inspect the fuel tank for leaks.

**FUEL SHUTOFF VALVE
(1988-1994 MODELS)**

The fuel shutoff valve is mounted on the left side of the fuel tank. A replaceable fuel filter is mounted at the top of the fuel shutoff valve.

Removal

Refer to Figure 99.

100

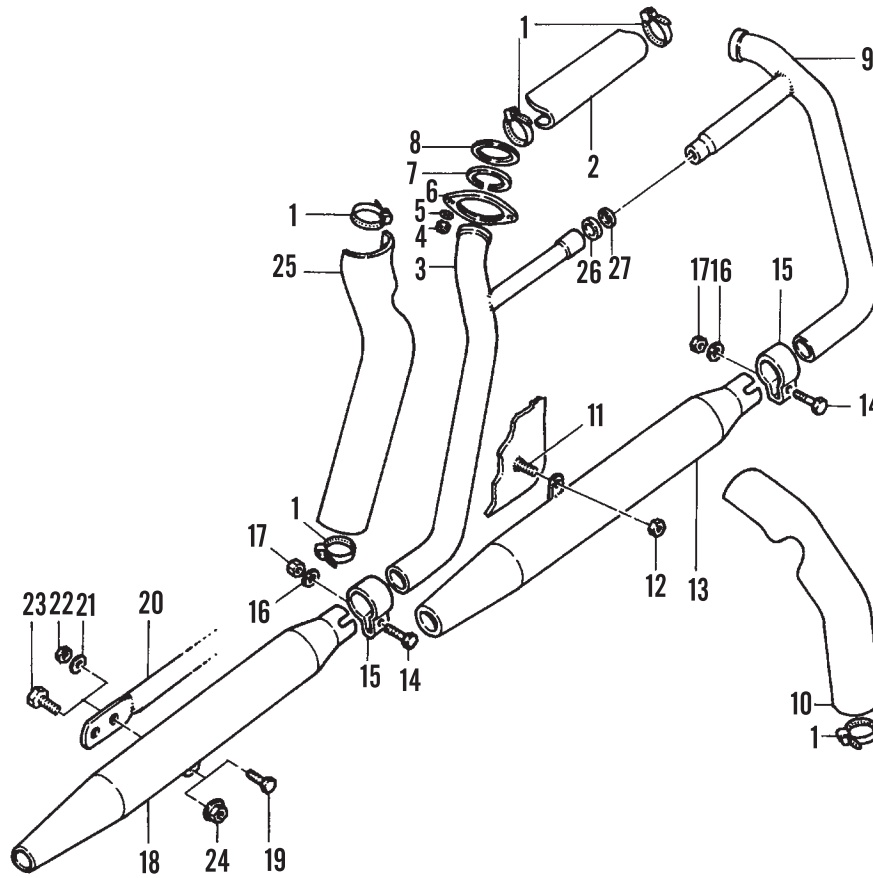
EXHAUST SYSTEM (ALL MODELS EXCEPT 883R MODELS)

- | | | | |
|--------------------------|-----------------------|----------------------------------|--------------------------------|
| 1. Clamp | 9. Front exhaust pipe | 17. Nut | 23. Bolt (1992-2003 models) |
| 2. Crossover heat shield | 10. Front heat shield | 18. Rear muffler | 24. Nut (1992-2003 models) |
| 3. Rear exhaust pipe | 11. Stud | 19. Bolt (1988-1991 models) | 25. Rear heat shield |
| 4. Nut | 12. Nut | 20. Muffer support | 26. Gasket |
| 5. Washer | 13. Front muffler | 21. Washer (1988-1991 models) | 27. Washer |
| 6. Clamp | 14. Bolt | 22. Nut (1988-1991 models) | |
| 7. Snap ring | 15. Clamp | | |
| 8. Gasket | 16. Washer | | |

1. Disconnect the battery negative cable (Chapter Twelve).
2. Turn the fuel valve off.
3. Disconnect the fuel supply hose (**Figure 96**) at the fuel shutoff valve. Account for the fuel line insulator. Connect a longer hose to the shutoff valve fitting and place the open end of the hose into a gas can. Turn the shutoff valve to reserve and drain the fuel into the tank.
4. Loosen the shutoff valve fitting and remove the shutoff valve from the fuel tank. Catch any gas that may leak from the tank after the valve is removed.

Cleaning and Inspection

1. Inspect the filter mounted on top of the fuel valve. Remove contamination from the filter. Replace the filter if it is damaged.

2. Install a new filter gasket before installing the filter onto the fuel valve.
3. Remove all sealant residue from the fuel tank and fuel valve threads.

Installation

1. Install a new filter gasket onto the fuel shutoff valve, then install the filter.
2. Coat the fuel valve threads with pipe sealant.
3. Insert the valve into the tank. Securely tighten the valve nut.
4. Remove the drain hose from the fuel tank and reconnect the fuel supply hose. Secure the fuel supply hose with a new hose clamp as described in *Fuel Hose And Clamps* in this



chapter. Make sure the insulator is placed over the fuel supply hose before reconnecting it.

5. Refill the fuel tank and check for leaks.

FUEL SHUTOFF VALVE (1995-2003 MODELS)

The 1995-2003 models are equipped with a vacuum-operated fuel shutoff valve mounted on the left side of the fuel tank. A replaceable fuel filter is mounted at the top of the fuel shutoff valve.

2003 models are equipped with a three-way vacuum-operated fuel shutoff valve.

To troubleshoot this valve, refer to *Fuel System* in Chapter Two.

Removal

1. Disconnect the negative battery cable (Chapter Twelve).
2. Turn the fuel shutoff valve to the off position.
3. Drain the fuel tank as described in the *Fuel Tank* in this chapter.
4. Disconnect the vacuum hose from the fuel shutoff valve.

5. Loosen the fuel valve nut and remove the fuel shutoff valve from the fuel tank. Drain gasoline remaining in the tank after valve removal.

Cleaning and Inspection

1. Inspect the filter mounted on top of the fuel valve. Remove contamination from the filter. Replace the filter if it is damaged.
2. Install a new filter gasket before installing the filter onto the fuel valve.
3. Remove all sealant residue from the fuel tank and fuel valve threads.

Installation

1. Install a new filter gasket onto the fuel shutoff valve, then install the filter.
2. Coat the fuel valve threads with pipe sealant.
3. Insert the fuel valve into the tank, then start the hex fitting onto the fuel tank threads two turns.
4. Hold the hex fitting and start the fuel valve into the fitting by turning it counterclockwise two turns.
5. Hold the fuel valve and tighten the hex fitting securely.
6. Reconnect the fuel hose to the fuel shutoff valve and secure it with a hose clamp. Secure the fuel supply with a new hose clamp as described in *Fuel Hose and Clamps* in this chapter.
7. Reconnect the vacuum hose to the valve.
8. Refill the fuel tank and check for leaks.

EXHAUST SYSTEM (ALL MODELS EXCEPT 883R MODELS)

Removal

Refer to **Figure 100**.

1. Secure the motorcycle on a suitable stand.
2. Remove the heat shields.
3. Remove the nuts and washers securing the front and rear exhaust pipes to the cylinder heads (**Figure 101**, typical).
4. To remove the front muffler nut (**Figure 102**), perform the following:
 - a. Remove the master cylinder mounting bolts (**Figure 103**) and lift the brake pedal upward.
 - b. Remove the front muffler nut (**Figure 102**).
- 5A. On 1988-1991 models, remove the nut, washer and bolt securing the rear muffler to the muffler support bracket.
- 5B. On 1992-2003 models, remove the locknut (**Figure 104**) and bolt attaching the rear muffler to the muffler support bracket.

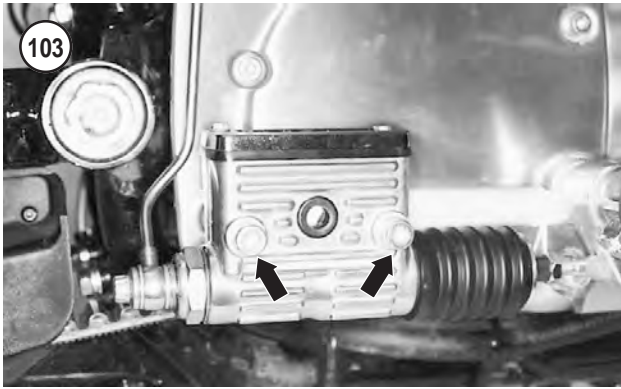

CAUTION

A bowed exhaust flange (**Figure 105**) may wedge against the exhaust studs preventing removal. If a flange is tight, remove one of the cylinder head studs; refer to *Service Methods* in Chapter One. Replace or flatten a distorted flange.

6. Slide the exhaust pipe flanges (**Figure 106**) away from the cylinder head studs.
7. Remove the exhaust as an assembly (**Figure 107**).
8. Remove and discard the exhaust port gaskets (**Figure 108**).



NOTE
To reduce the possibility of an exhaust leak, muffler clamps should be replaced if removed.

9. Loosen the muffler clamp bolts and remove the mufflers from the exhaust pipes.
10. Inspect the exhaust system as described in this section.

Installation

1. Before installing the new exhaust port gaskets, remove all carbon residue from the gasket and pipe fitting surfaces. Wipe the port with a rag, then align the new gasket with the port and push it into place. The new gasket should fit snugly in the port (**Figure 109**). Repeat for the other exhaust port and gasket.
2. If an exhaust stud was removed, install the stud now. Refer to the *Service Method* in Chapter One.
3. Before installing the exhaust pipes, check that the snap rings (**Figure 110**) holding the flanges on the exhaust pipes fit tightly in the pipe grooves.
4. Position the exhaust pipe assembly, without mufflers, so that the front and rear exhaust pipes fit into the front and rear cylinder head exhaust pipes. Slide the flanges onto the mounting studs and install a washer and nut (**Figure 101**) onto each stud. Install the nuts finger-tight only.
5. Install new muffler clamps and their fasteners over the end of the exhaust pipes as shown in **Figure 100**. Then slide each muffler onto its respective exhaust pipe.





6. Turn the front muffler so that its mounting tab engages the stud as shown in **Figure 100** and **Figure 102**. Install the locknut finger-tight.

7A. On 1988-1991 models, align the rear muffler tab with the muffler support bracket and install the bolt, washer and nut finger-tight only.

7B. On 1992-2003 models, align the rear muffler tab with the muffler support bracket and install the bolt and locknut (**Figure 104**) finger-tight only.

NOTE

*Be sure to install the rear muffler mounting bolt assembly in the direction shown in **Figure 100**.*

8. Tighten the exhaust fasteners in the following order to the torque specified in **Table 3**:

- a. Cylinder head flange nuts (**Figure 101**).
- b. Front and rear muffler clamp nuts (**Figure 111**).
- c. Front muffler locknut (**Figure 102**).
- d. Rear muffler fasteners (**Figure 104**, typical).
- e. Rear master cylinder mounting bolts (**Figure 100**).

9. Wipe the exhaust pipes and mufflers with a clean rag to remove all traces of oil and grease.

10. Install the heat shields and secure with the mounting clamps.

11. Start the engine and check for leaks. Some smoke will be evident after starting, especially if rust penetrant was used on the hose clamps or if oil and grease residue was not wiped off of the exhaust pipes and mufflers.

Inspection

- 1. Check the exhaust pipe for cracks or spots that have rusted through. Replace a damaged or leaking pipe.
- 2. Remove all rust from all pipe and muffler mating surfaces.
- 3. Check all of the clamps for damage or severe rusting. Clean or repair clamps as required.
- 4. If the exhaust flange is distorted (**Figure 105**), repair or replace it before reinstalling it. Perform the following:
 - a. Each exhaust flange is secured to its exhaust pipe with a snap ring (**Figure 110**). Pry the ring out of its groove and remove the flange. Discard the ring. See **Figure 112**.

- b. Examine the flange for distortion or other damage; the flange must be flat to fit properly onto the exhaust studs. Distortions may be flattened out, but make sure the edges or holes in the flange are not deformed when straightening it. Replace a damaged or bent flange.
 - c. Check the fit of the flange on the cylinder head studs before installing it onto the pipe.
 - d. Clean the end of the pipe to remove all rust and other debris. If reinstalling a used flange, clean the inside of the flange thoroughly.
 - e. Slide the flange on the exhaust pipe so the shoulder on the flange faces toward the snap ring groove. Install a new snap ring and check its fit; it must be secure in its groove.
 - f. Repeat for the other exhaust pipe and flange, if required.
5. Replace worn or damaged heat shield clamps as required.
 6. Store the exhaust pipes in a safe place until they are reinstalled.

EXHAUST SYSTEM (883R MODELS)

Removal

Refer to **Figure 113**.

1. Secure the motorcycle on a suitable stand.
2. Remove the heat shields.
3. Remove the nuts and washers securing the front and rear exhaust pipes to the cylinder heads (**Figure 101**, typical).
4. Remove the bolts securing the muffler to the support bracket.

CAUTION

*A bowed exhaust flange (**Figure 105**) may wedge against the exhaust studs preventing removal. If a flange is tight, remove one of the cylinder head studs; refer to **Service Methods** in Chapter One. Replace or flatten a distorted flange.*

5. Slide the exhaust pipe flanges (**Figure 106**) away from the cylinder head studs.
6. Remove the exhaust as an assembly.
7. Remove and discard the exhaust port gaskets (**Figure 108**).
8. Loosen the muffler clamp bolts and remove the muffler from the exhaust pipes.
9. Inspect the exhaust system as described in this section.

Installation

1. Before installing the new exhaust port gaskets, remove all carbon residue from the pipe fitting surfaces in the exhaust port. Wipe the port with a rag, then align the new gas-

ket with the port and push it into place. The new gasket should fit snugly in the port (**Figure 109**). Repeat for the other exhaust port and gasket.

2. If an exhaust stud was removed, install the stud now. Refer to the *Service Methods* in Chapter One.
3. Before installing the exhaust pipes, check that the snap rings (**Figure 110**) holding the flanges on the exhaust pipes fit tightly in the pipe grooves.
4. Position the exhaust pipe assembly, without the muffler, so the front and rear exhaust pipes fit into the front and rear cylinder head exhaust pipes. Slide the flanges onto the mounting studs and install a washer and nut onto each stud (**Figure 101**). Install the nuts finger-tight only.
5. Install a new muffler clamp and fastener onto the end of the exhaust pipes.
6. Slide the muffler onto the exhaust pipe.
7. Turn the muffler so that mounting holes in the muffler align with the bolt holes in the support bracket. Install, but do not tighten, the mounting bolts.
8. Tighten the fasteners in the following order:
 - a. Tighten the cylinder head flange nuts (**Figure 101**) to 72-96 in.-lb. (8-11 N•m).
 - b. Tighten the Torca clamp bolt on the muffler to 35-40 ft.-lb. (48-54 N•m).
 - c. Tighten the muffler mounting bolts to 120-180 in.-lb. (14-20 N•m).
9. Wipe the exhaust pipes and mufflers with a clean rag to remove all traces of oil and grease.
10. Install the heat shields and secure with the mounting clamps.
11. Start the engine and check for leaks. Some smoke will be evident after starting, especially if rust penetrant was used on the hose clamps or if oil and grease residue was not wiped off the exhaust pipes and mufflers.

Inspection

Follow the steps described in *Exhaust System (All Models Except 883R Models)* in this chapter.

EVAPORATIVE EMISSION CONTROL SYSTEM (CALIFORNIA MODELS)

All of the California models covered by this manual are equipped with an evaporative emission control system. This system is used to prevent gasoline vapors from escaping into the atmosphere. When the engine is not running, fuel vapor from the fuel tank is routed through the vapor valve and stored in a carbon canister. When the engine is running, these vapors are drawn through a purge hose and into the carburetor where they are burned in the combustion chambers. The vapor valve also prevents gasoline vapors from escaping from the carbon canister if the motorcycle should fall onto its side.

Two evaporative emission control systems are used on the California models covered by this manual.

113

EXHAUST SYSTEM (883R MODELS)

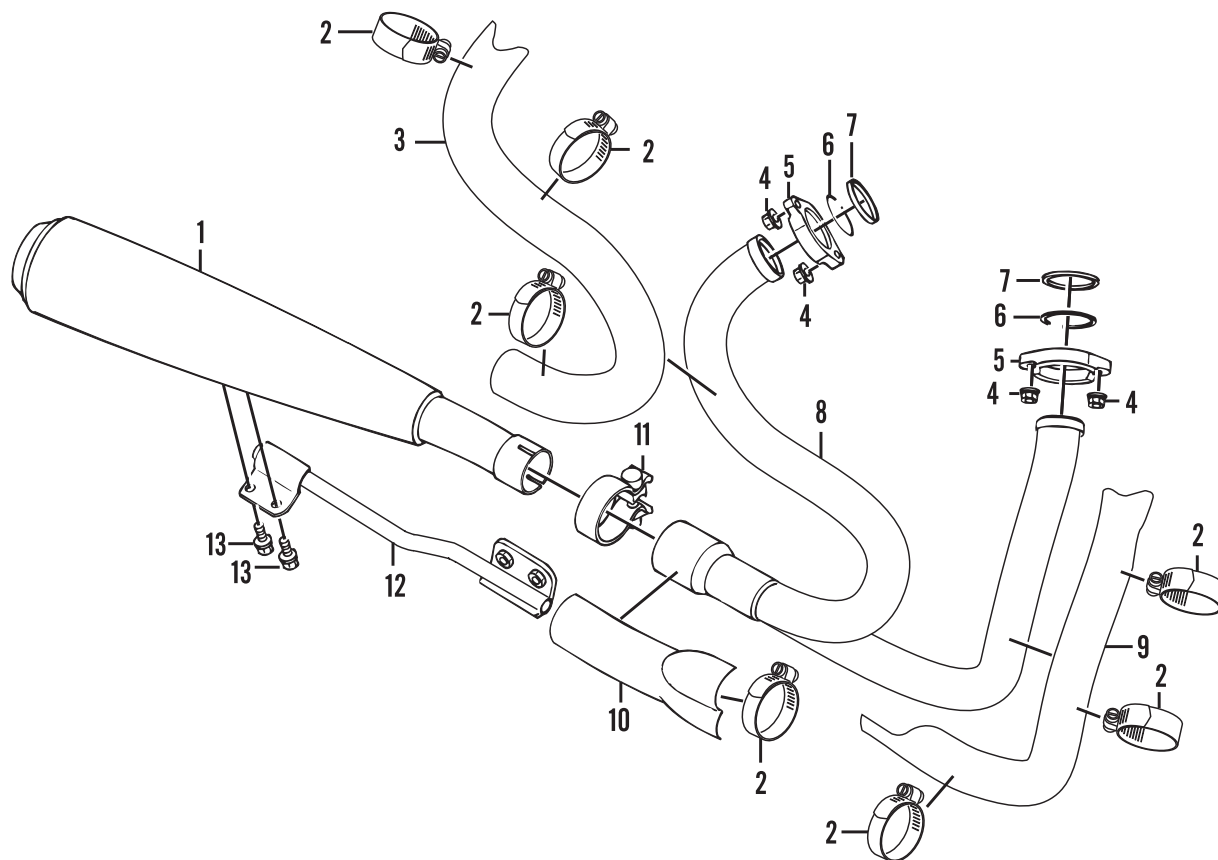

- 1. Muffer
- 2. Clamp
- 3. Rear heat shield
- 4. Nut
- 5. Flange
- 6. Snap ring
- 7. Gasket
- 8. Exhaust pipe
- 9. Front head shield
- 10. Collector heat shield
- 11. Torca clamp
- 12. Support bracket
- 13. Bolt

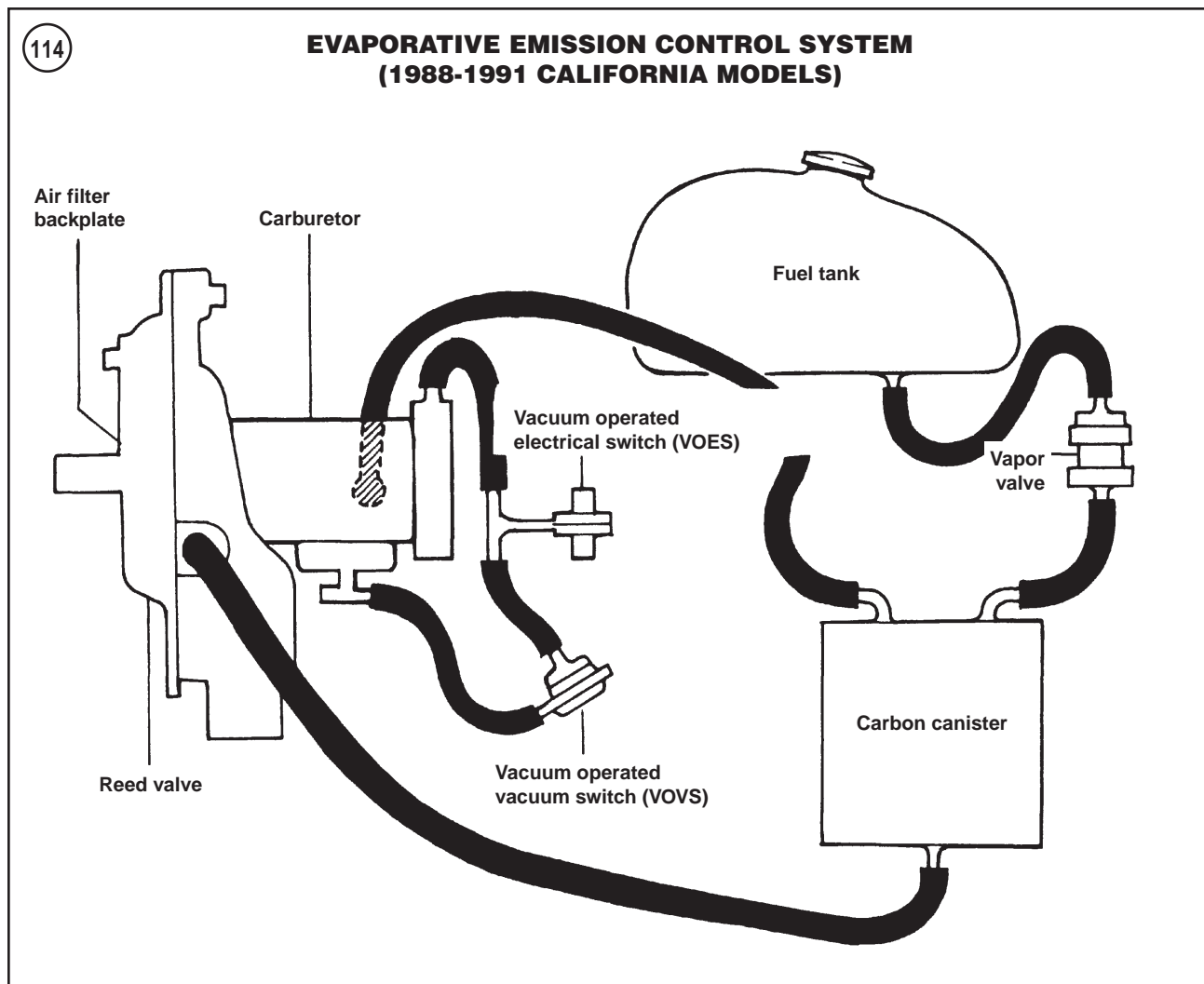

Refer to **Figure 114** or **Figure 115** for the components and the hose routing to the various parts. Before removing the hoses from any of the parts, label the hose and the fitting to identify the hose location.

Inspection/Replacement

WARNING

Make sure the fuel tank vapor hoses are routed so they cannot contact hot engine or exhaust components. These hoses contain flammable vapors. If a hose melts from contacting a hot part, leaking vapors may ignite, causing severe motorcycle damage and rider injury.

1. Check all emission control lines or hoses to make sure they are correctly routed and properly connected.
2. Make sure there are no kinks in the lines or hoses and that there are no signs of excessive wear or burning on lines routed near engine hot spots.
3. Check the physical condition of all lines and hoses in the system for cuts, tears or loose connections. Damaged lines or hoses should be replaced.
4. Check all components in the emission control system for signs of damage, such as broken fittings or broken nipples on the component.
5. When replacing one or more lines or hoses, refer to the appropriate diagram. Disconnect one end of the line from the component, then connect one end of the new line to the component fitting. Disconnect the other end of the line and connect the other end of the new line. This method lessens the possibility of incorrectly connected and routed hoses.

Vapor Valve Replacement

The vapor valve (**Figure 116**) is mounted on the frame tube between the battery and oil tank.

1. Remove the battery as described in Chapter Twelve.
2. Label the hoses at the vapor valve and then disconnect them.

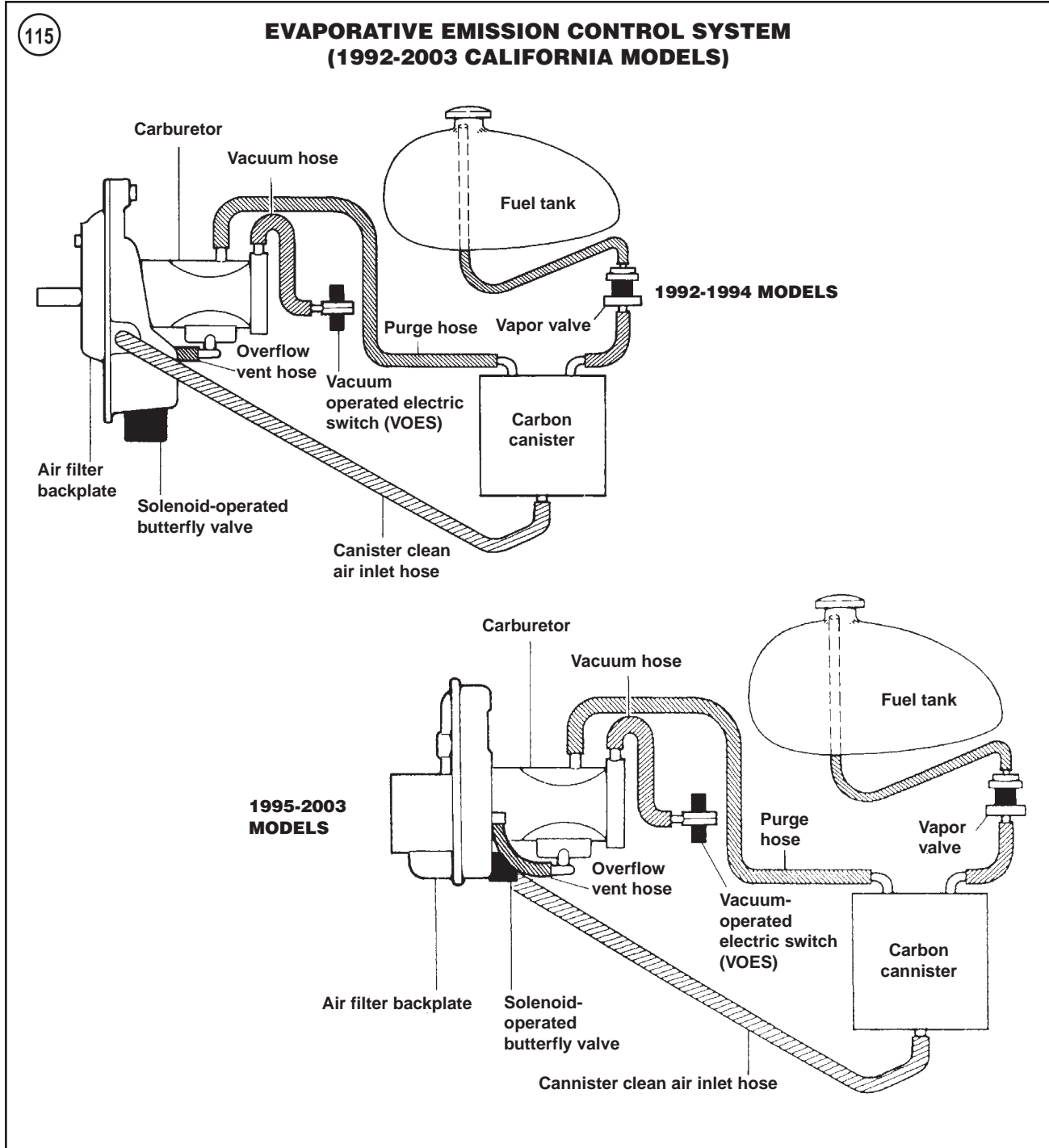

3. Note that one end of the vapor valve is longer than the other end. The longer end must point up when the vapor valve is installed on the motorcycle. Remove and replace the vapor valve.

CAUTION

The vapor valve must be installed in a vertical position with the longer end pointing up or excessive pressure will build in the fuel tank.

4. Install by reversing the removal steps.

Carbon Canister Replacement

Refer to **Figure 117** or **Figure 118**.

The carbon canister is mounted on the bottom side of the swing arm.

1. Remove the canister guard mounting screws and remove the guard.
2. On 1990-2003 models, cut the canister cable strap. Discard the strap.
3. Label and then disconnect the hoses from the canister. Plug the open end of each hose to prevent contamination.

4. Press the canister bracket locking tab and slide the canister toward the left side of the motorcycle and off the bracket.
5. If necessary, remove the canister bracket mounting fasteners and mounting plate assembly and remove the canister bracket.

CAUTION

Do not alter the carbon canister position. The canister must be mounted below the carburetor to work correctly.

6. Install by reversing the removal steps.

Reed Valves Replacement (1988-1991 Models)

Whenever the air filter backplate is removed from the motorcycle, check the reed valve assembly for broken reed valves. To replace damaged reed valves, perform the following:

1. Remove the air filter backplate as described in this chapter.
2. Remove the screws securing the reed cover to the reed support and remove the cover (**Figure 119**).
3. Refer to **Figure 120**. Remove the screws securing the reed bottom to the reed support. Then remove the following parts:
 - a. Reed bottom.
 - b. Reed top.
 - c. Reed stop.
4. Check the reeds for cracks or debris that would prevent the reed from closing. Replace worn or damaged parts as required.
5. Refer to **Figure 120**. Attach the reed bottom, reed top and the reed stop to the reed support cover. Secure with the attaching screws.
6. Install the reed support cover onto the reed support and secure with the attaching screws (**Figure 119**).
7. Install the air filter backplate as described in this chapter.

Vacuum Operated Valve Switch Testing/Replacement (1988-1991 Models)

The vacuum-operated vacuum switch (VOVS) closes off the carburetor float bowl vent passage when the engine is not running. This prevents fuel vapor from escaping when the engine is off.

A hand-operated vacuum pump (part No. HD-23738 or equivalent) is required to test the VOVS.

1. Label and then disconnect the hoses from the VOVS; see **Figure 114** and **Figure 121**.
2. Attach a vacuum pump to port A in **Figure 121**.
3. Apply 1-2 in. HG vacuum to the valve while watching the pump gauge. The vacuum should remain steady. If vacuum reading decreases rapidly, the diaphragm is damaged.
4. If vacuum remains constant, blow into port C; air should pass through the VOVS. If air cannot pass through, the VOVS is damaged.



5. Remove the vacuum pump and blow into port B; air should not pass through the VOVS. If air can pass through, the VOVS is damaged.
6. If the VOVS failed to react as described in Steps 3-5, replace it with a new one.

Solenoid-Operated Butterfly Valve Troubleshooting (1992-2003 Models)

On 1992-2003 California models, a solenoid-operated butterfly valve is installed in the air filter backplate to seal off the backplate when the ignition switch is off. This valve prevents fuel vapors from escaping into the atmosphere. Turning the ignition switch to the on or ignition position energizes the solenoid hold-in windings. When the start switch is operated, the solenoid pull-in windings are energized. The hold-in windings will keep the butterfly valve open until the ignition switch is turned off.

Test the solenoid-operated butterfly valve if the engine suffers from sluggish acceleration and the engine's top speed is 40 mph.

1. Make sure all of the hoses are properly connected; see **Figure 115**.
2. If the butterfly valve is not opening and closing properly due to mechanical problem perform the following:
 - a. Check the mechanical linkage assembly (**Figure 122**) for corroded, loose, broken or missing components. The butterfly valve linkage and plunger should be cleaned every 5000 miles as described in this section.
 - b. Check for a broken solenoid spring (**Figure 122**). If the spring is broken, replace the solenoid assembly. The spring cannot be replaced separately. Replace the assembly as described in this chapter.

Solenoid-Operated Butterfly Valve Electrical Testing (1992-2003 Models)

Prior to testing the solenoid valve, fabricate the test harness shown in **Figure 123**.

117

CARBON CANISTER (1988-1989 CALIFORNIA MODELS)

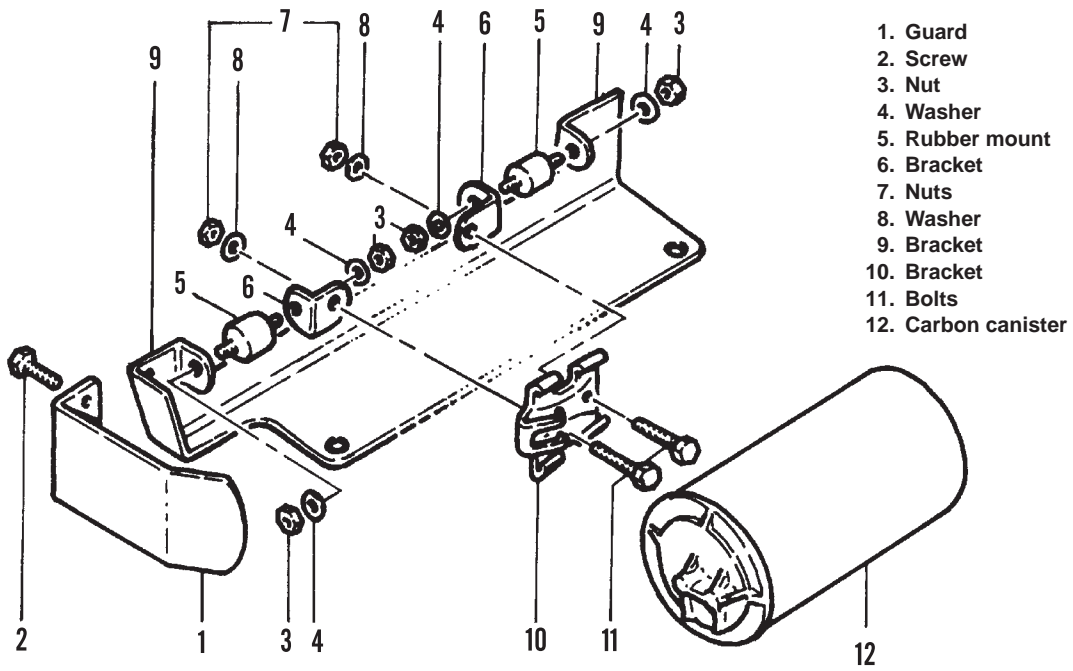

- 1. Guard
- 2. Screw
- 3. Nut
- 4. Washer
- 5. Rubber mount
- 6. Bracket
- 7. Nuts
- 8. Washer
- 9. Bracket
- 10. Bracket
- 11. Bolts
- 12. Carbon canister

118

CARBON CANISTER (1990-2003 CALIFORNIA MODELS)

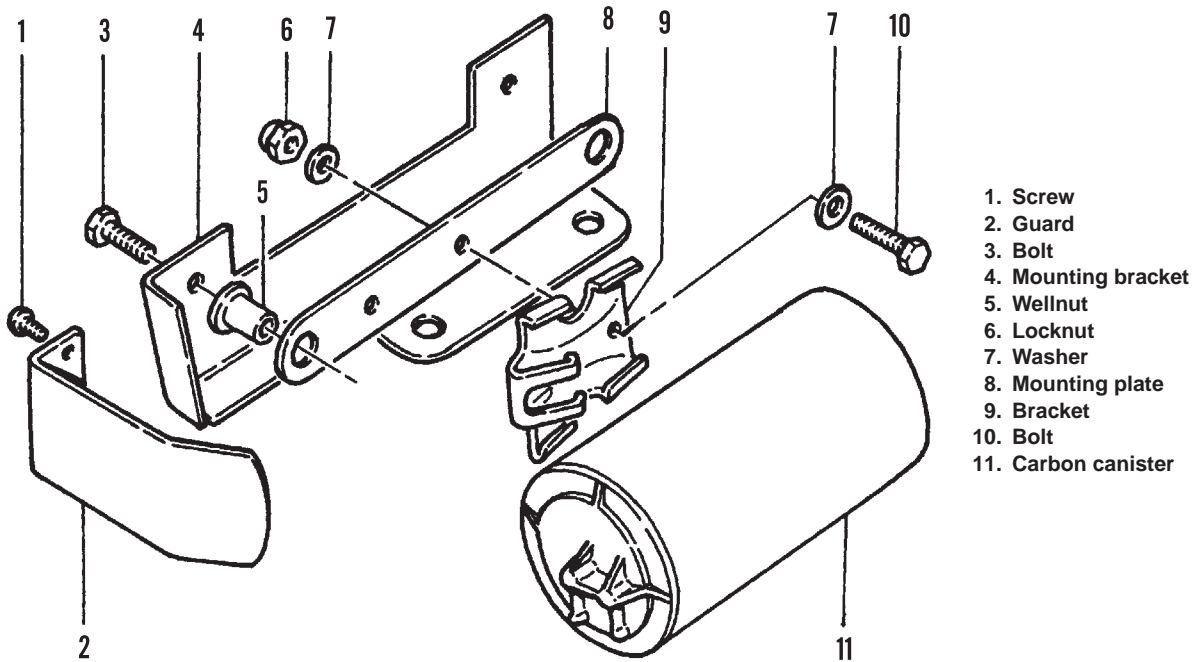

- 1. Screw
- 2. Guard
- 3. Bolt
- 4. Mounting bracket
- 5. Wellnut
- 6. Locknut
- 7. Washer
- 8. Mounting plate
- 9. Bracket
- 10. Bolt
- 11. Carbon canister

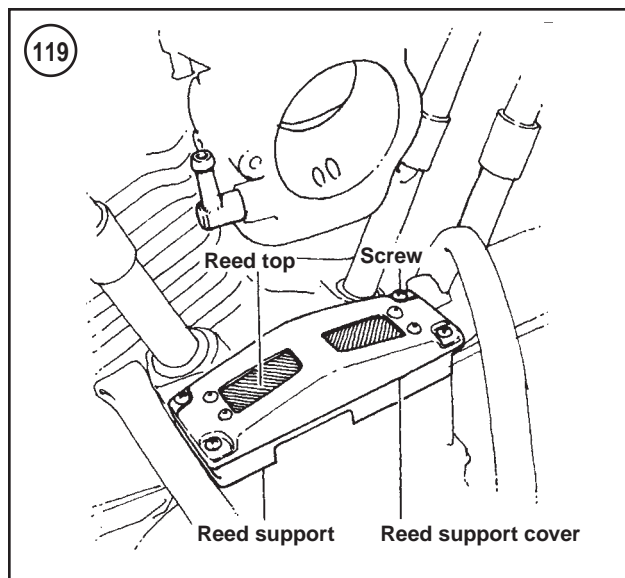

Solenoid winding resistance test

1. Remove the air filter backplate as described in this chapter.
2. Disconnect the solenoid valve electrical connector (**Figure 122**).
3. Check for dirty or loose-fitting terminals and connectors.
4. Connect the solenoid test connector to the solenoid connector (**Figure 124**).
5. Refer to **Figure 125** for test connections and values and compare your meter readings to the stated values. If any of the meter readings differ from the specified values, replace the solenoid as described in this section.
6. If the resistance readings are correct, perform the pull-in coil test as described in this section.

Pull-in coil test

A fully charged 12-volt battery is required for this test.

1. Remove the air filter backplate as described in this chapter.
2. Disconnect the solenoid valve electrical connector (**Figure 122**).
3. Check for dirty or loose-fitting terminals and connectors.
4. Connect the solenoid test connector to the solenoid connector (**Figure 124**).
5. Connect a 12-volt battery to the two solenoid test connector wires shown in **Figure 126**. The butterfly valve should open when battery voltage is applied. Disconnect the battery connections and note the following:
 - a. If the butterfly valve now opens but did not open when originally connected to the wiring harness, perform Step 6.
 - b. If the butterfly valve did not open, check the linkage for corroded, missing or damaged parts. If the linkage assembly appears okay, retest with a new solenoid.
6. Perform the following:

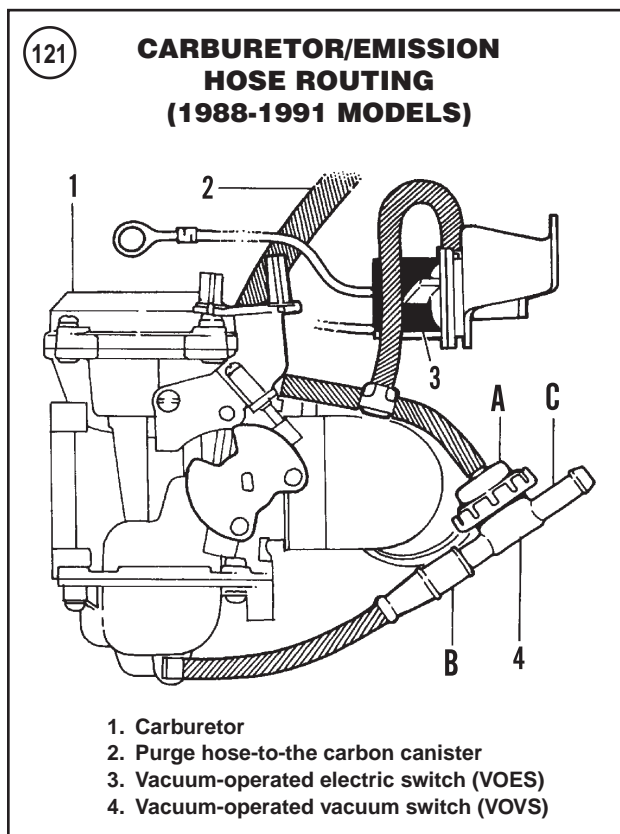
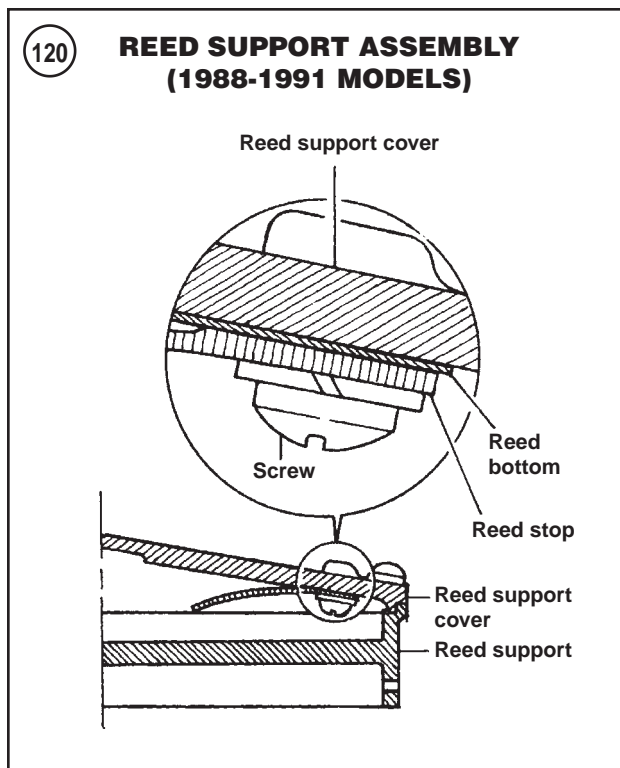

- a. Make sure the ohmmeter is set to the appropriate scale. On 1992-1994 models, check for ground at the gray/black lead in the solenoid connector. On 1995-2003 models, check for ground at the black lead in

122

**SOLENOID/BUTTERFLY VALVE ASSEMBLY
(1992-2003 CALIFORNIA MODELS)**

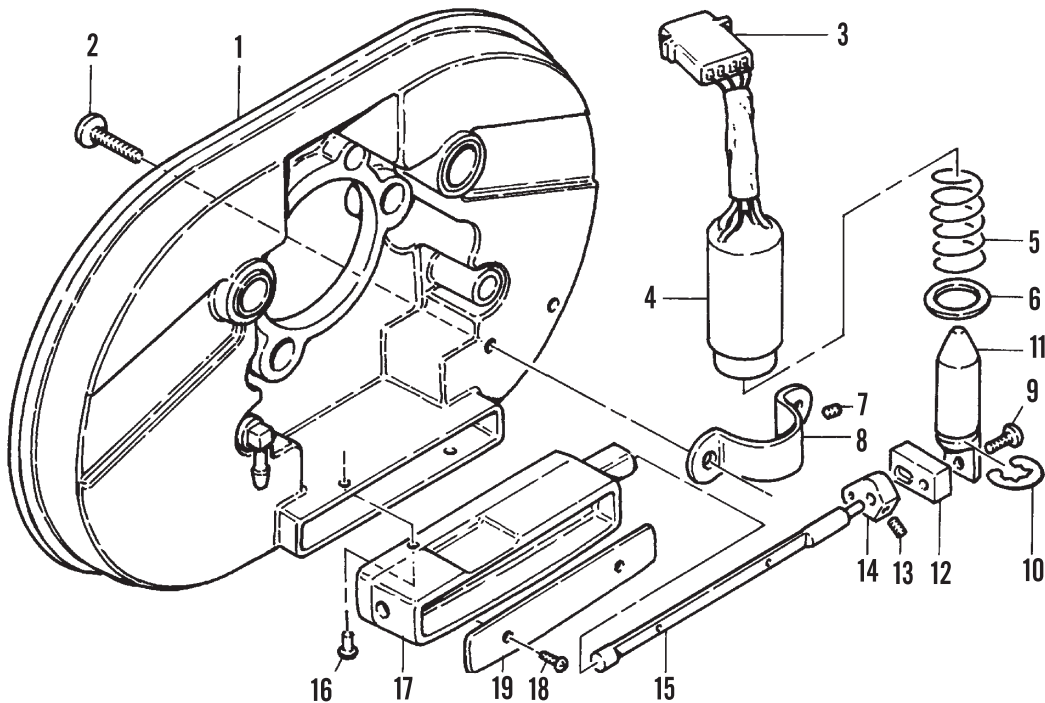

- | | |
|-------------------------|---------------------|
| 1. Air filter backplate | 11. Plunger |
| 2. Screw | 12. Plastic link |
| 3. Connector | 13. Setscrew |
| 4. Solenoid | 14. Lever arm |
| 5. Spring | 15. Shaft |
| 6. Plastic washer | 16. Rivet |
| 7. Setscrew | 17. Housing |
| 8. Clamp | 18. Housing |
| 9. Screw | 19. Butterfly plate |
| 10. E-clip | |

- lead in the solenoid connector. The ohmmeter should read 1 ohm or less.
- b. Reconnect the solenoid 4-prong connector.
- c. Switch a voltmeter to the 12 VDC scale.
- d. On 1992-1994 models, connect the positive voltmeter lead to the black/red lead in the solenoid connector. On 1995-2003 models, connect the positive voltmeter lead to the green lead in the solenoid connector. Connect the negative voltmeter lead to a good engine ground. Press the start button while reading the voltage indicated on the voltmeter. It should be 12 volts.

- 7. If any of the meter readings differ from those specified in Step 6, there is a problem in the solenoid wiring harness. Use voltage and resistance checks to locate the damaged wire(s). After repairing the wire(s), repeat the above checks.
- 8. If the meter readings were correct as performed in Step 7, perform the hold-in test as described in this section.

Hold-in coil test

A fully charged 12-volt battery is required for this test.

123

SOLENOID TEST CONNECTOR

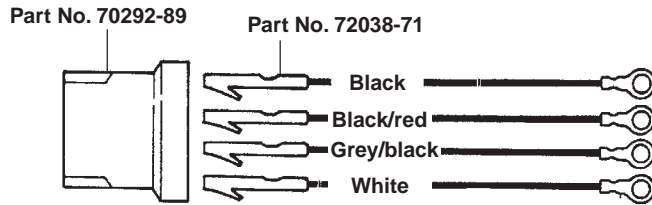

**TEST HARNESS
1992-1993 MODELS**

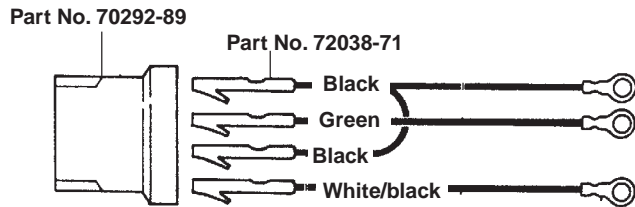

**TEST HARNESS
1994-1996 MODELS**

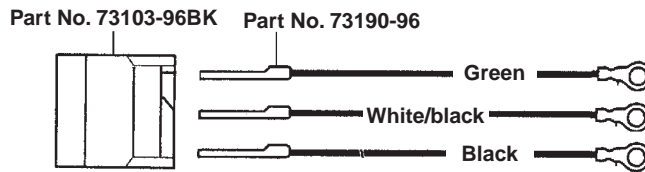

**TEST HARNESS
1997-2003 MODELS**

124

RESISTANCE TEST

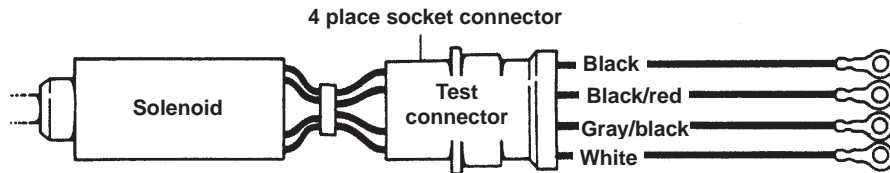

1992-1993 MODELS

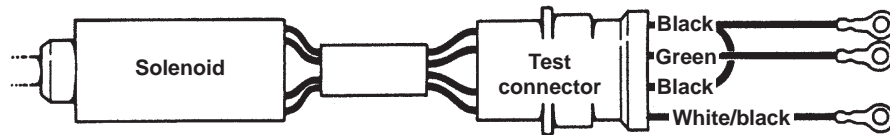

1994-1996 MODELS

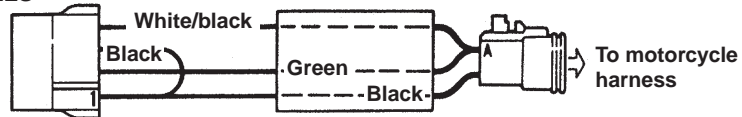

1997-2003 MODELS

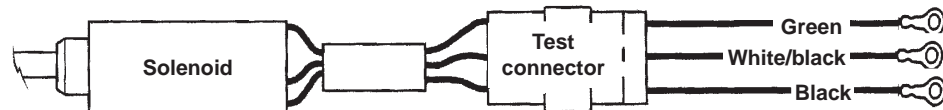

125

| TEST | POSITIVE PROBE (+) | NEGATIVE PROBE (-) | RESISTANCE |
|-------------------------|--------------------|--------------------|------------|
| 1992-1993 MODELS | | | |
| Pull-in | Black/Red | Gray/Black | 4-6 Ohms |
| Hold-in | White | Black | 21-27 Ohms |
| 1994-2003 MODELS | | | |
| Pull-in | Green | Black | 4-6 Ohms |
| Hold-in | White/Black | Black | 21-27 Ohms |

126

SOLENOID PULL-IN COIL TEST

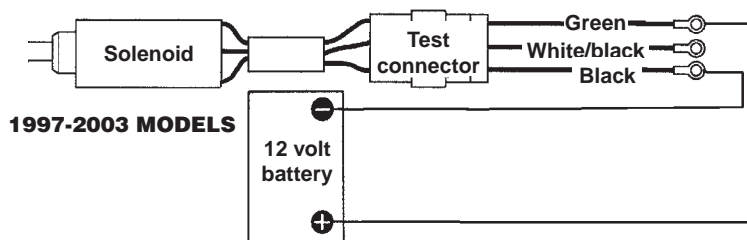
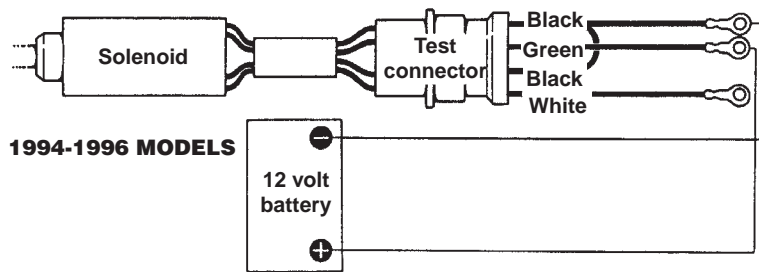
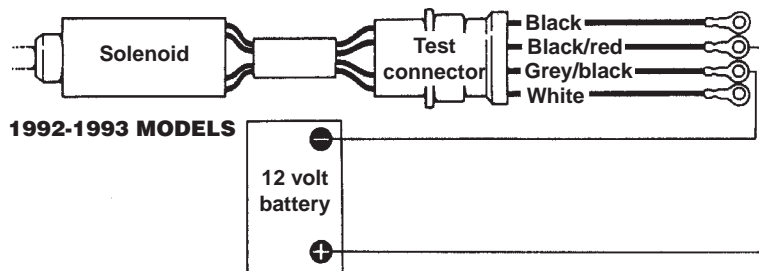

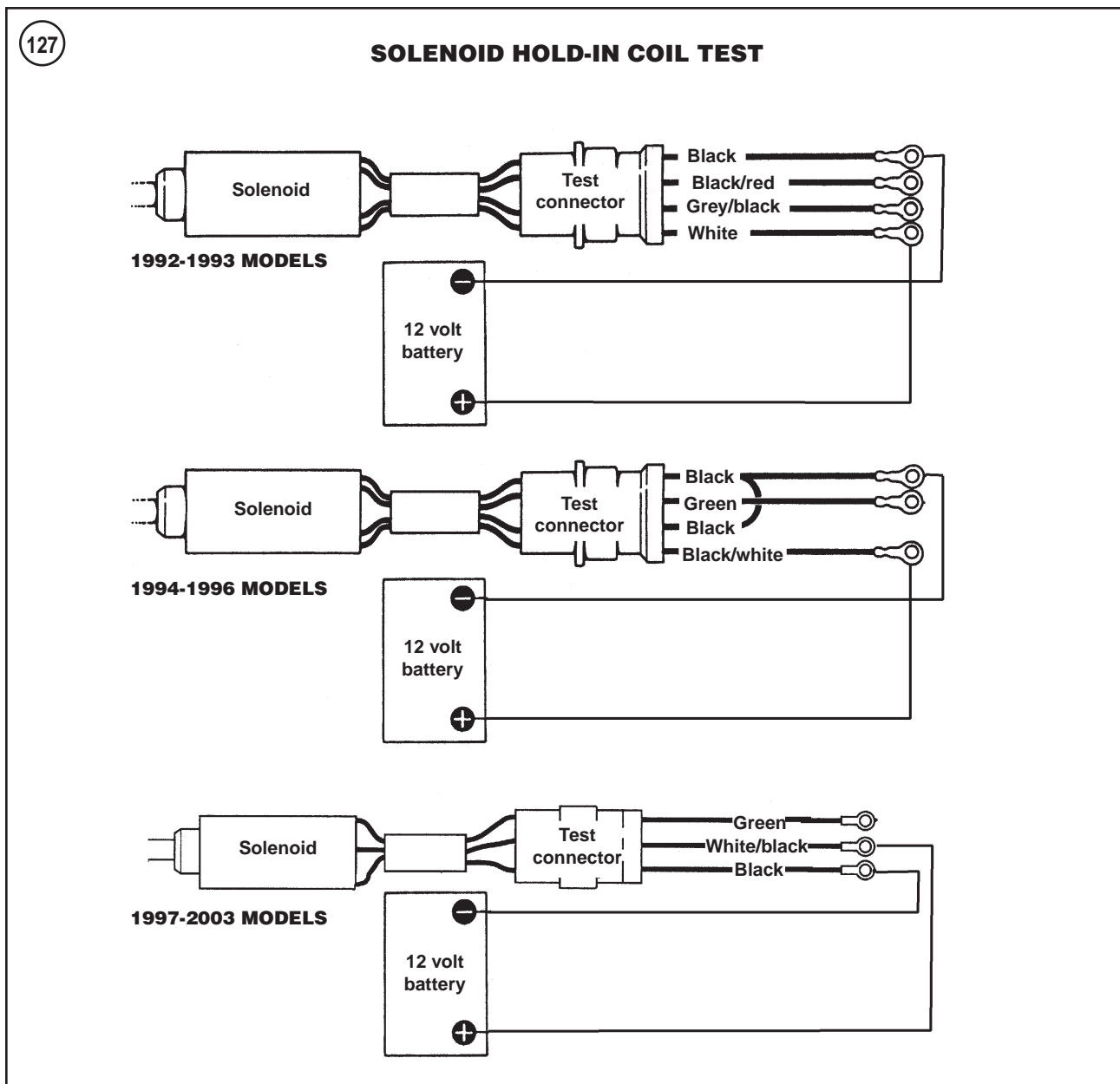

1. Remove the air filter backplate as described in this chapter.
2. Disconnect the solenoid valve electrical connector (**Figure 122**).
3. Check for dirty or loose-fitting terminals and connectors.
4. Connect the solenoid test connector to the solenoid connector (**Figure 124**).
5. Connect a 12-volt battery to the two solenoid test connector wires shown in **Figure 127** and perform the following:
 - a. Open the butterfly valve carefully with a screwdriver by pushing inward on the top side of the butterfly valve.
 - b. Remove the screwdriver. The butterfly valve should remain open as long as the solenoid hold-in windings are energized.
 - c. Disconnect the negative battery cable from the solenoid test connector. The butterfly valve should close.
6. If the butterfly valve did not remain open in Step 5, substep b, perform the following:
 - a. Switch an ohmmeter to $R \times 1$ and cross the test leads. Check for ground at the black connector pin in the solenoid connector. The ohmmeter should read 1 ohm or less.
 - b. Reconnect the solenoid connector.
 - c. Switch a voltmeter to the 12 VDC scale.
- d. If the butterfly valve operated as described in substeps b and c, the solenoid hold-in windings are operating correctly.
- e. If the butterfly valve failed to operate properly, perform Step 6.
- f. Disconnect the positive battery cable from the solenoid test connector.

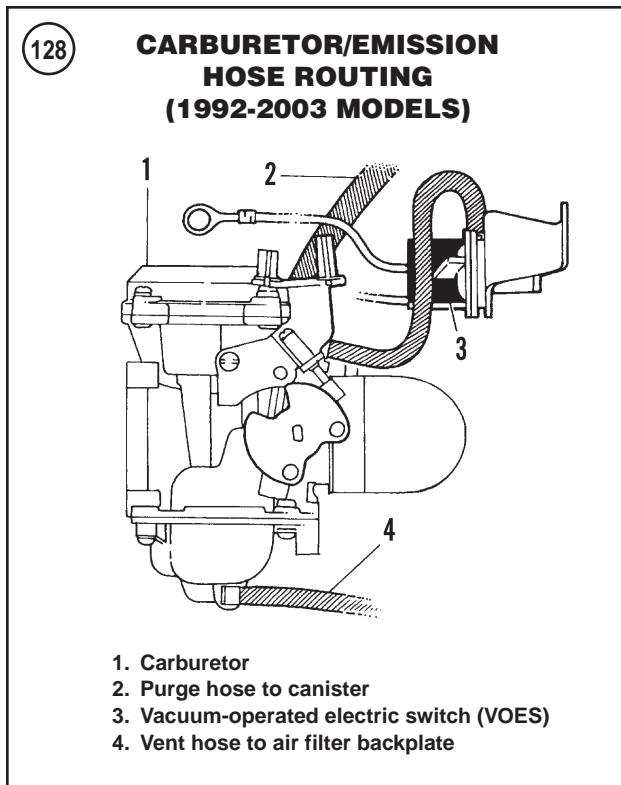

- d. On 1992-1994 models, connect the positive voltmeter lead to the white lead in the solenoid connector. On 1995-2003 models, connect the positive voltmeter lead to the white/black lead in the solenoid connector. Connect the voltmeter negative lead to a good engine ground. Turn the ignition switch to the on or ignition position and read the voltage indicated on the voltmeter. It should be 12 volts.
7. If any of the meter readings differ from those specified in Step 6, there is a problem in the solenoid wiring harness. Use voltage and resistance checks to locate the damaged wire(s). After repairing the wire(s), repeat the above checks.
8. If the solenoid test readings were correct but the butterfly valve does not work properly, perform the tests in the *Solenoid-Operated Butterfly Valve Mechanical (1992-2003)* in this section.
9. Remove all test equipment and reconnect the solenoid connector.

Solenoid-Operated Butterfly Valve Cleaning and Lubrication (1992-2003 Models)

Refer to **Figure 122**.

1. Remove the air filter backplate as described in this chapter.
2. At every 2500 mile (4022 km) interval, inspect the butterfly valve and solenoid for proper operation.
3. At every 5000 mile (8045 km) interval, spray the butterfly valve and plunger with carburetor cleaner. Then, after

the carburetor cleaner evaporates, lubricate the linkage and plunger with a dry film spray lubricant.

4. Reinstall the air filter backplate as described in this chapter.

Solenoid-Operated Butterfly Valve Removal/Installation/Adjustment (1992-2003 Models)

Refer to **Figure 122**.

1. Remove the air filter backplate as described in this chapter.
2. Remove the plunger mounting screw.
3. Loosen the lever arm setscrew.
4. Slide the solenoid up to free it from the clamp and remove it.

NOTE

*An original equipment replacement solenoid does not include the connector housing, pin terminals (3, **Figure 122**) or the conduit. When replacing the solenoid, install the pin terminals (part No. HD 72039-71) onto the solenoid wires, and reuse the connector housing and conduit from the old solenoid. Make sure each pin terminal is properly seated in the connector housing.*

5. Slide the solenoid into the clamp.
6. Apply threadlock (Loctite 242 or equivalent) to the plunger mounting screw and lever arm setscrew threads.

NOTE

When assembling the plunger and plastic link, the slot in the plastic link must face toward the pin on the lever arm.

7. Align the deep flat side on the plunger with the plastic link, then install the plunger mounting screw. Tighten the screw securely.
8. Loosen the solenoid setscrew.
9. Push the plunger up until the butterfly valve opens fully and hold it in this position. Then position the solenoid body inside the clamp.
10. While still lifting the plunger up so the butterfly valve is fully open, press down on top of the solenoid until the bottom of the solenoid just touches the plastic washer. Tighten the solenoid setscrew securely.
11. Release the plunger and check that the solenoid spring closes the butterfly valve completely. If not, readjust the plunger and solenoid.
12. Install the air filter backplate as described in this chapter.

Emission/Carburetor Hose Routing (All Models)

Refer to **Figure 121** or **Figure 128** for emission hose routing at the carburetor.

Table 1 CARBURETOR SPECIFICATIONS

| | 883 models | 1200 models |
|--|-----------------------------------|-----------------------------------|
| Carburetor jet sizes | | |
| U.S. models (except California) | | |
| Main jet | | |
| 1988 models | 170 | 200 |
| 1989-1991 models | 175 | 175 |
| 1992-1995 models | 160 | 170 |
| 1996 models | 160 | 179 |
| 1997 models | 160 | 170 |
| 1998-2003 models | 160 | |
| 1200 and 1200C | | 170 |
| 200S | | 195 |
| Pilot jet | | |
| 1988 models | 35 | 35 |
| 1989-1991 models | 45 | 45 |
| 1992-1995 models | 40 | 40 |
| 1996-2003 models | 42 | 42 |
| California | | |
| Main jet | | |
| 1988 models | 165 | 180 |
| 1989 models | 155 | 160 |
| 1990-1991 models | 160 | 160 |
| 1992 models | 160 | 170 |
| 1993-1997 models | 170 | 185 |
| 1998-2003 models | 170 | |
| 1200 and 1200C | | 185 |
| 1200S | | 195 |
| Pilot jet | | |
| 1988 models | 35 | 35 |
| 1989 models | 42 | 42 |
| 1990-1991 models | 42 | 42 |
| 1992-1995 models | 40 | 40 |
| 1996-2003 models | 42 | 42 |
| HDI models | | |
| Main jet | | |
| 1993-1994 models | 160 | 160 |
| 1995-1997 models | 190 | 190 |
| 1998 models | 190 | |
| 1200 and 1200C | | 190 |
| 1200S | | 195 |
| 1999-2003 models | 190 | 200 |
| Pilot jet | | |
| 1993-1994 models | 40 | 40 |
| 1995-2003 models | 42 | 42 |
| Swiss models | | |
| Main jet | | |
| 1995 models | 160 | 160 |
| 1996-1997 models | 190 | 190 |
| 1998 models | 190 | |
| 1200 and 1200C | | 190 |
| 1200S | | 195 |
| 1999-2003 models | 190 | 200 |
| Pilot jet | | |
| 1995 models | 40 | 40 |
| 1996-2003 models | 42 | 42 |
| Float height | | |
| 1988-1991 models | 0.725-0.730 in. (18.4-18.5 mm) | 0.725-.730 in. (18.4-18.5 mm) |
| 1992-2003 models | 0.413-0.453 in. (10.5-11.5 mm) | 0.413-0.453 in. (10.5-11.5 mm) |

Table 2 FUEL SYSTEM TORQUE SPECIFICATIONS

| | ft.-lb. | in.-lb. | N•m |
|--|----------------|----------------|------------|
| Air filter retaining screws (HDI models) | – | 20 | 2 |
| Backplate-to-carburetor screws | – | 36-60 | 4-7 |
| Backplate-to-cylinder head bolts | – | 120-144 | 14-16 |
| Fuel tank mounting bolts | | | |
| 1988-1992 models | – | 108 | 12 |
| 1993-2003 models | – | 96-192 | 11-22 |
| Intake manifold mounting bolts and nuts | – | 72-120 | 8-14 |

Table 3 EXHAUST SYSTEM TORQUE SPECIFICATIONS

| | ft.-lb. | in.-lb. | N•m |
|-------------------------------------|----------------|----------------|------------|
| Cylinder head exhaust flange nuts | – | 72-96 | 8-11 |
| Front muffler locknut | | | |
| 1991-1992 models | 50-60 | – | 68-81 |
| 1993-2003 models | 20-40 | – | 27-54 |
| Muffler clamp nut | | | |
| 1988-1993 models | – | 84 | 9 |
| Muffler mounting bolts | – | 120-180 | 14-20 |
| Rear master cylinder mounting bolts | – | 155-190 | 18-21 |
| Torca muffler clamp bolt | | | |
| 1994-2003 models | 35-40 | – | 48-54 |

CHAPTER TWELVE

ELECTRICAL SYSTEM

This chapter covers the electrical system. Refer to Chapter Three for spark plug maintenance information.

Tables 1-4 are located at the end of this chapter. Wiring diagrams are located at the end of this manual.

ELECTRICAL COMPONENT REPLACEMENT

Most motorcycle dealerships and parts suppliers will not accept the return of any electrical part. If the exact cause of an electrical system malfunction cannot be determined, have a dealership retest that specific system to verify the test results. This may help avert the possibility of purchasing an expensive, unreturnable part that does not fix the problem.

Consider any test results carefully before replacing a component that tests only slightly out of specification, especially resistance. A number of variables can affect test results dramatically. These include: the testing meter's internal circuitry, ambient temperature and conditions under which the machine has been operated. All instructions and specifications have been checked for accuracy; however, successful test results depend to a great degree upon individual accuracy.

ELECTRICAL CONNECTORS

Many electrical problems can be traced to damaged wiring, or contaminated or loose connectors.

The locations of the connectors vary by model. Also, if the motorcycle has been serviced previously, the connector may be in a different location.

The electrical system uses three types of connectors. If individual wires or terminals of a particular connector require repair or replacement, refer to *Electrical Connectors* in this chapter.

Always check the wire colors listed in the procedure or wiring diagrams to verify the location of the components.

Perform the following steps first if an electrical system fault is encountered:

1. Inspect all wiring for fraying, burning and other visual damage.
2. Check the main fuse and make sure it is not blown. Replace it if necessary.
3. Check the individual fuse(s) for each circuit. Make sure it is not blown. Replace it if necessary.

4. Inspect the battery as described in this chapter. Make sure it is fully charged and the battery cables are clean and securely attached to the battery terminals.
5. Clean connectors with an aerosol electrical contact cleaner. After a thorough cleaning, pack multi-pin electrical connectors with dielectric grease to seal out moisture.
6. Disconnect electrical connectors in the suspect circuits and check for bent or damaged terminals. The male and female terminals must connect or an open circuit will result.
7. Make sure the terminals are pushed all the way into the plastic connector. If they are not, carefully push them in with a narrow-blade screwdriver.
8. After everything is checked, push the connectors together and make sure they are fully engaged and locked together.
9. Never pull on the electrical wires when disconnecting an electrical connector. Only pull on the connector plastic housing.

BATTERY (1986-1996 MODELS)

WARNING

Always wear safety glasses when working with batteries. If electrolyte is splashed into the eyes, call a physician immediately, force the eyes open and flood with cool, clean water for approximately 15 minutes.

WARNING

When performing the following procedures, protect eyes, skin and clothing.

CAUTION

Do not spill battery electrolyte on painted or polished surfaces. The liquid is highly corrosive and will damage the finish. If it is spilled, wash it off immediately with soapy water and thoroughly rinse with clean water.

Clean and inspect the battery at periodic intervals. The original equipment battery on 1986-1996 models is a conventional lead-acid battery.

On all models in this manual, the negative side is the ground. When removing the battery, disconnect the negative cable first, then the positive cable. This minimizes the chance of a tool shorting to ground when disconnecting the battery positive cable.

Safety Precautions

When working with lead-acid batteries, use extreme care to avoid spilling or splashing the electrolyte. This solution contains sulfuric acid, which can ruin clothing and cause serious chemical burns. If any electrolyte is spilled or splashed on clothing or skin, immediately neutralize with a solution of baking soda and water, then flush with clean water.

While batteries are being charged, explosive hydrogen gas forms in each cell. Some of this gas escapes through filler cap openings and may form an explosive atmosphere in and around the battery. This condition can persist for several hours. Sparks, open flame or a lighted cigarette can ignite the gas causing an internal battery explosion and possible serious personal injury.

Take the following precautions to prevent an explosion:

1. Do not smoke or permit any open flame near any battery being charged or which has been recently charged.
2. Do not disconnect live circuits at battery terminals because a spark can occur.
3. Take care when connecting or disconnecting any battery charger. Be sure the charger power switch is off before making or breaking connections. Poor connections are a common cause of electrical arcs which cause explosions.
4. Keep all children and pets away from charging equipment and batteries.

For maximum battery life, check the battery periodically for electrolyte level, state of charge and corrosion. During hot weather periods, frequent checks are recommended. If the electrolyte level is below the bottom of the vent well in one or more cells, add distilled water as required—tap water will shorten battery life. To assure proper mixing of the water and acid, operate the engine immediately after adding water. *Never* add battery acid instead of water.

Cable Service

1. If the electrical cable terminals are corroded, disconnect them from the electrical system.
2. Clean each connector with a wire brush and a baking soda solution. Rinse thoroughly with clean water and wipe dry with a clean cloth.
3. After cleaning, apply a thin layer of dielectric grease to the battery terminals before reattaching the cables.
4. Reconnect the electrical cables to the electrical system if they were disconnected.
5. After connecting the electrical cables, apply a light coat of dielectric grease to the terminals to retard corrosion and decomposition of the terminals.

Removal

1. Remove the seat (Chapter Seventeen).
2. Remove the battery strap (A, **Figure 1**).
3. Remove the battery top cover (B, **Figure 1**).
4. Disconnect the negative battery cable from the battery (**Figure 2**).
- 5A. On 1986-1993 models, remove the positive battery cable bolt, red wire running from the main circuit breaker, positive battery cable and spacer (**Figure 3**).
- 5B. On 1994-1996 models, remove the positive battery cable bolt, positive battery cable and spacer (**Figure 4**).
6. Disconnect the battery vent tube from the battery.
7. Remove the battery.

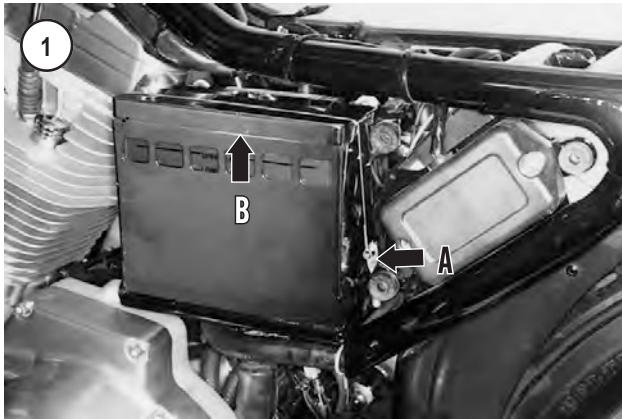

Electrolyte Level Check

1. Maintain the electrolyte level between the marks on the battery case (Figure 5).
2. If the electrolyte level must be adjusted, remove the battery as described in this section. Do not add water while the battery is still in the frame as any spilled water along with electrolyte will flow onto the frame and cause corrosion.
3. Be sure all cell caps are in place and tight.
4. If the electrolyte level is correct, reinstall the battery.

Cleaning, Inspection and Adding Water

1. Inspect the battery tray and cushion (A, Figure 6, typical) for contamination or damage. Clean with a solution of baking soda and water.
2. Check the battery case (Figure 7) for cracks, warp, discoloration or other damage.
3. Check the battery hold-down strap for acid damage, cracks or other damage. Replace the strap if required.
4. Check the positive battery cable routing connection in the battery tray. Tighten the bolt, if necessary.

CAUTION

Do not allow cleaning solution to enter the battery cells or the electrolyte level will be seriously weakened.

5. Check the battery terminal parts for corrosion or damage. Clean the parts with a solution of baking soda and water. Replace severely corroded or damaged parts.
6. Clean the top of the battery with a stiff bristle brush using the baking soda and water solution.
7. If necessary, remove the battery tray and clean and/or replace damaged parts.
8. Check the battery cable clamps for corrosion and damage. If corrosion is minor, clean the battery cable clamps with a stiff wire brush. Replace worn or damaged cables.

NOTE

Do not overfill the battery cells. The electrolyte expands due to heat from charging and

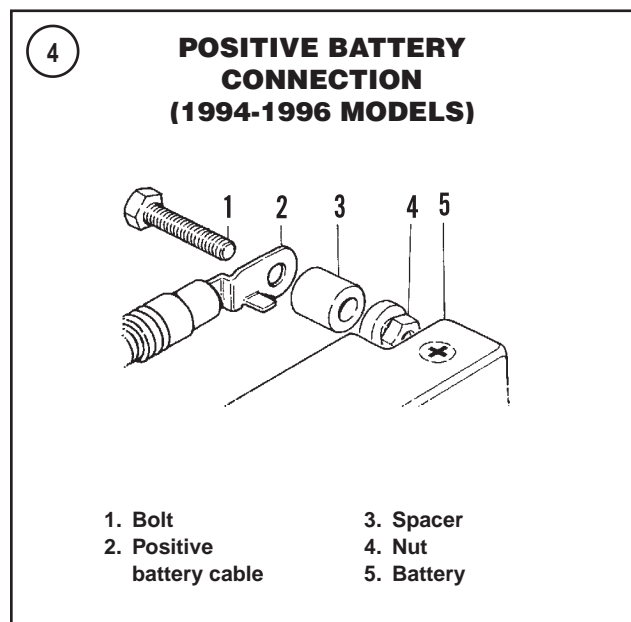
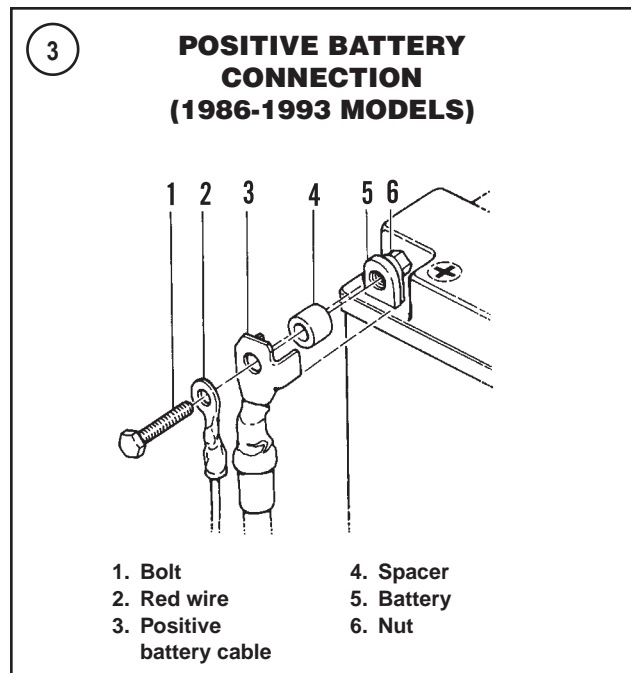

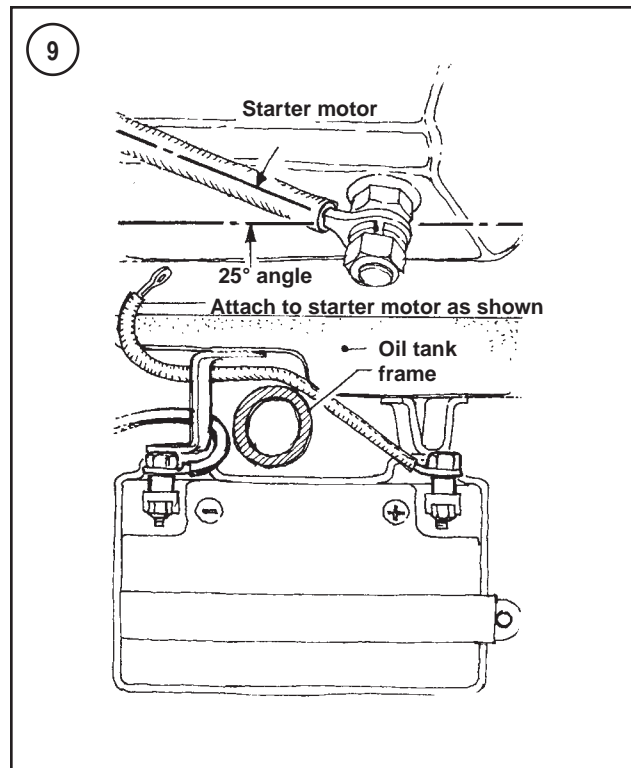
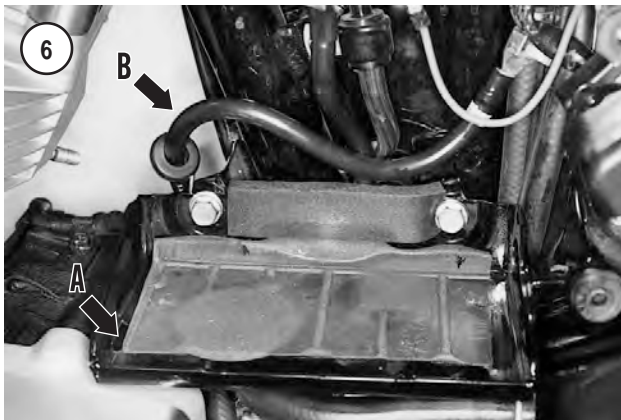

will overflow if, the level is above the upper level line.

9. Remove the caps (A, **Figure 8**) from the battery cells and check the electrolyte level. Add distilled water, if necessary, to bring the level within the upper and lower level lines on the battery case (**Figure 7**).

Installation

1A. On 1986-1988 models, note in **Figure 9** the proper routing of the battery cables. If the positive cable is routed incorrectly, the oil tank may cut the cable insulation and cause an electrical short.

1B. On 1989-1996 models, note in B, **Figure 6** the proper routing of the positive battery cable. On later models a cable guide secures the cable to the battery tray.

2A. On 1986-1993 models, install the spacer, positive battery cable, red wire and bolt (**Figure 3**). Tighten the bolt securely.

2B. On 1994-2003 models, install the spacer, positive battery cable and bolt (**Figure 4**). Tighten the bolt securely.

3. Reposition the battery into the battery tray. Make sure the rubber cushion (A, **Figure 6**) is installed in the bottom of the tray before installing the battery. Install the battery strap to secure the battery.

CAUTION

Be sure the battery cables are connected to their proper terminals. Connecting the battery backward will reverse the polarity and damage the rectifier.

4. Install and tighten the negative battery cable (**Figure 2**).
5. Coat the battery connections with dielectric grease or petroleum jelly.
6. Place the top cover (**B, Figure 1**) on the battery.
7. Attach the forward end of the battery strap (**A, Figure 1**) under the front side of the battery tray. Then lay the strap over and into the groove in the battery top. Insert the threaded stud on the rear end of the battery strap into the hole at the rear side of the battery tray. Install the washer and nut. Tighten the nut securely.

WARNING

After installing the battery, make sure the vent tube is not pinched. A pinched or kinked tube will allow high pressure to accumulate in the battery and cause the battery to explode. If the vent tube is damaged, replace it.

8. Reconnect the battery vent tube to the battery. If necessary, refer to the *Vent Tube Routing* in this section.
9. Install the seat (Chapter Seventeen).

Vent Tube Routing

The battery vent tube must be routed properly and not touch any moving parts. Proper routing ensures the vent hose outlet (**A, Figure 10**) is positioned away from all metal components. Replace the vent tube if it is kinked or plugged.

Connect the vent tube onto the battery vent nipple. The vent nipple is on the forward side of the battery (**B, Figure 8**). Following the transmission housing curve, route the tube past the transmission and insert the hose through the vent hose clip on the frame (**B, Figure 10**). On California models, continue by inserting the vent tube through the additional vent tube clip mounted on the rear muffler mount. On California models, the vent tube must extend 3 in. (76 mm) down from the bottom of the second clip. On all other models, the vent tube must extend 3.5 in. (89 mm) down from the bottom of the clip.

Testing

NOTE

Do not attempt to test a battery with a hydrometer immediately after adding water to the cells. Charge the battery for 15-20 minutes at a high rate to cause vigorous gassing.

Use a hydrometer with numbered graduations from 1.100 to 1.300 rather than one with color-coded bands to test the battery. To use the hydrometer (**Figure 11**), squeeze the rubber ball, insert the tip into the cell and release the ball.

Draw enough electrolyte to float the weighted float inside the hydrometer. When using a temperature-compensated hydrometer, release the electrolyte and repeat this process several times to make sure the thermometer has ad-

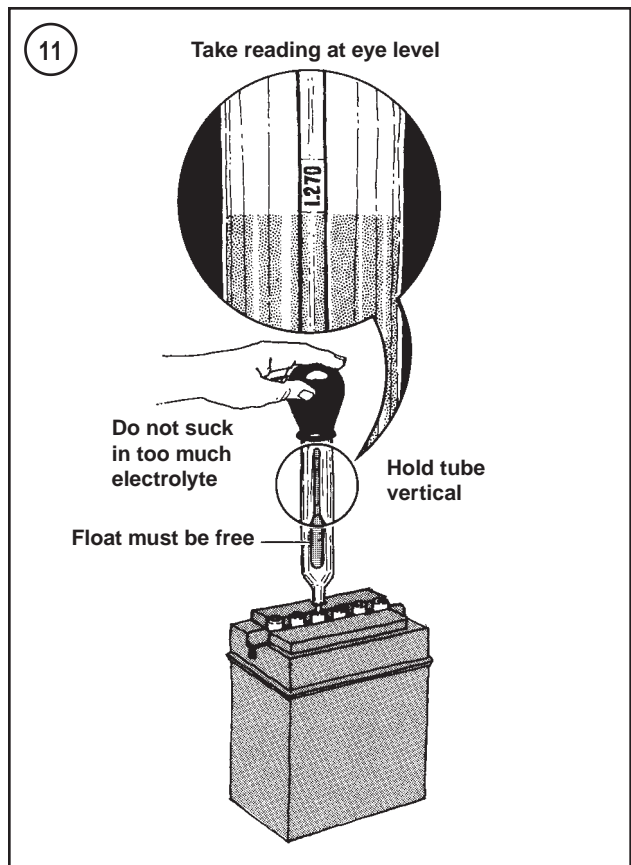
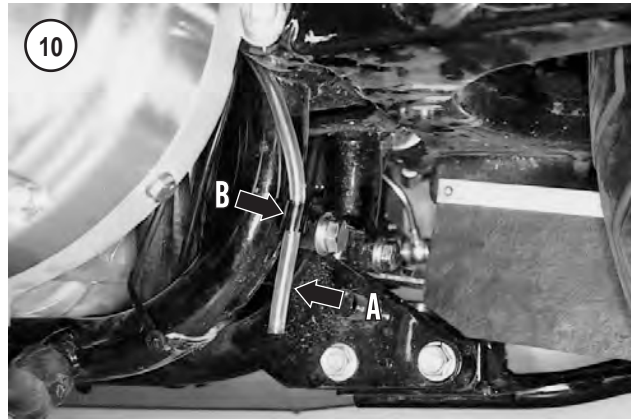

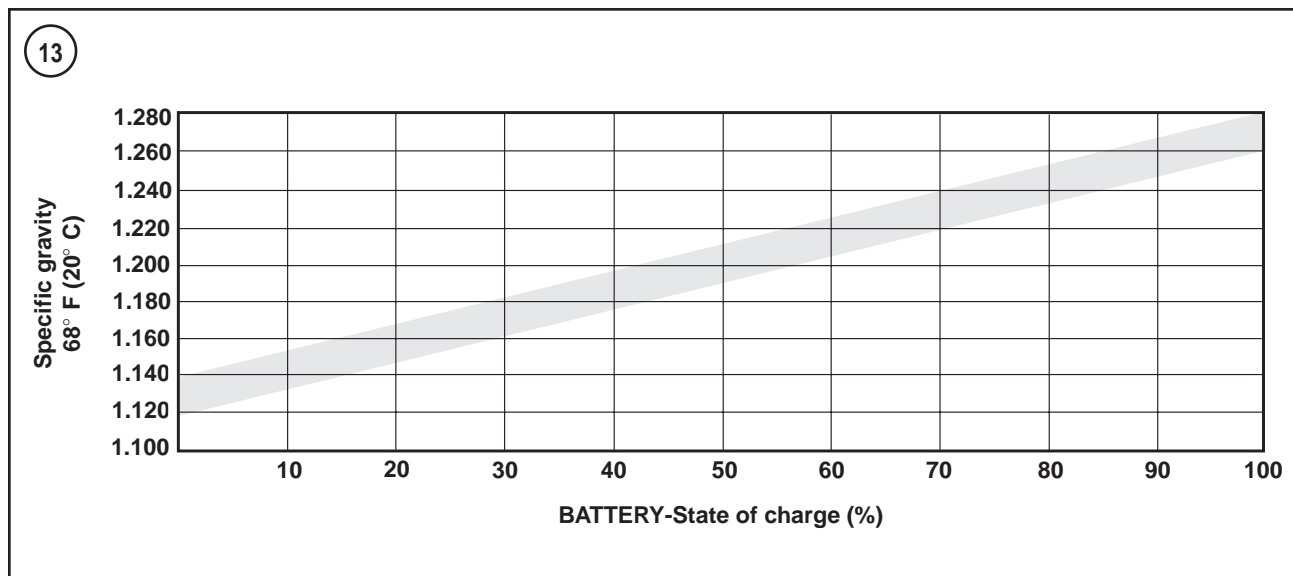

justed to the electrolyte temperature before taking the reading.

NOTE

If a temperature-compensated hydrometer is not used, add 0.004 to the specific gravity reading for every 10° above 80° F (27° C). For every 10° below 80° F (27° C), subtract 0.004.

Hold the hydrometer vertically and note the number in line with the surface of the electrolyte (**Figure 11**). This is the specific gravity for this cell. Return the electrolyte to the cell from which it came. The specific gravity of the electrolyte in each battery cell is an excellent indication of the condition of the cell. Refer to **Figure 11**. Charging is necessary if the specific gravity is lower or varies more than 0.050 from cell to cell. After charging, if the specific gravity still varies more than 0.050, replace the battery.

Test the charging system as described in Chapter Two.

Charging

A good battery should self-discharge approximately one percent of its given capacity (**Figure 12**) each day. If a battery not in use and without any loads connected loses its charge within a week of being fully charged, the battery is defective.

If the motorcycle is not used for long periods of time, an automatic charger with variable voltage and amperage outputs is recommended for optimum battery service life.

WARNING

During charging, highly explosive hydrogen gas is released from the battery. Only charge the battery in a well-ventilated area away from open flames, including pilot lights on some gas home appliances. Do not allow smoking in the area. Never check the charge of the battery by

arcing across the terminals; the resulting spark can ignite the hydrogen gas.

CAUTION

Always remove the battery from the motorcycle before connecting the charging equipment.

1. Remove the battery from the motorcycle as described in this section.
2. Set the battery on a stack of newspapers or shop cloths to protect the surface of the workbench.
3. Make sure the battery charger is turned off prior to attaching the charger leads to the battery.
4. Connect the positive charger lead to the positive battery terminal and the negative charger lead to the negative battery terminal.
5. Remove all fill/vent caps (A, **Figure 8**) from the battery. Set the charger at 12 volts and switch it on. Normally, a battery should be charged at a slow charge rate of 1/10 of the given capacity.
 - a. As the battery charges, the electrolyte will begin to bubble (gassing). If one cell does not bubble, it is usually an indication that it is defective. Refer to the *Load Testing* in this section.
 - b. The charging time depends on the discharged condition of the battery. Normally, a battery should be charged at a slow charge rate of 1/10 of the given capacity.

CAUTION

Maintain the electrolyte level at the upper level during the charging cycle; check and re-fill with distilled water as necessary.

6. After the battery has been charged for the predetermined time, turn off the charger, disconnect the leads, and check the specific gravity. It should be within the limits in **Figure 13**. If it is and remains stable for one hour, the battery is charged.

Initialization

A new battery must be fully charged to a specific gravity of 1.260-1.280 before installation. To bring the battery to a full charge, give it an initial charge. Using a new battery without an initial charge will cause permanent battery damage. That is, the battery will never be able to hold more than an 80% charge. Charging a new battery after it has been used will not bring its charge to 100%. When purchasing a new battery, verify its charge status.

NOTE

Recycle the old battery. When a new battery is purchased, turn in the old one for recycling. Most dealerships will accept the old battery in trade when purchasing a new one. Never place an old battery in the household trash because it is illegal, in most states, to place any acid or lead (heavy metal) contents in landfills.

Load Testing

A load test checks the battery performance under full current load and is the best indication of battery condition.

A battery load tester is required for this procedure. When using a load tester, follow the manufacturer's instructions.

1. Remove the battery from the motorcycle as described in this section.

NOTE

Let the battery stand for at least one hour after charging prior to performing this test.

2. The battery must be fully charged before beginning this test. If necessary, charge the battery as described in this section.

WARNING

The battery load tester must be turned off prior to connecting or disconnecting the test cables to the battery. Otherwise, a spark could cause the battery to explode.

CAUTION

To prevent battery damage during load testing, do not load-test a discharged battery and do not load-test the battery for more than 20 seconds. Performing a load test on a discharged battery can result in permanent battery damage.

3. Load test the battery as follows:
 - a. Connect the load tester cables to the battery following the manufacturer's instructions.
 - b. Load the battery at 50 percent of the cold-cranking amperage (CCA).
 - c. After 15 seconds, the voltage reading with the load still applied must be 9.6 volts or higher at 70° F (21°

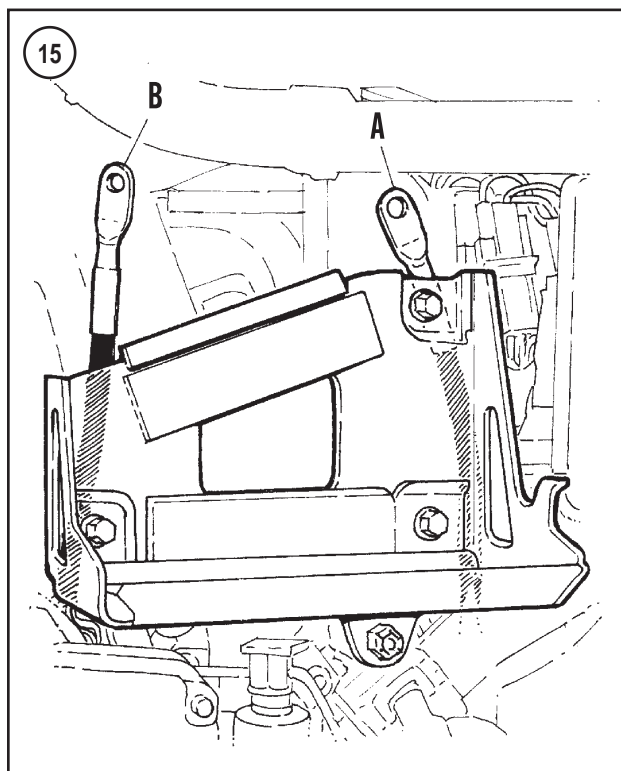
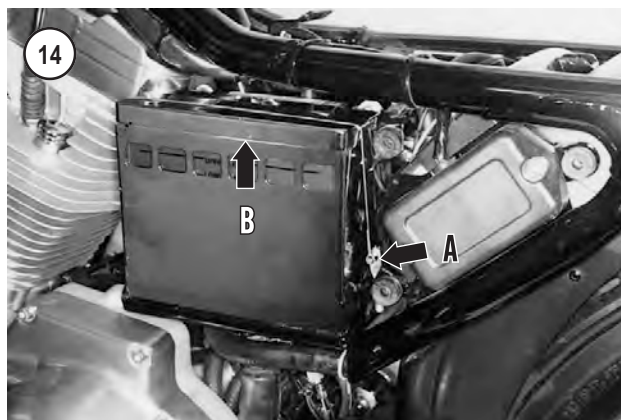

C). Now quickly remove the load and turn off the tester.

4. If the voltage reading is 9.6 volts or higher, the battery output capacity is good. If the reading is below 9.6 volts, the battery is defective.
5. With the tester off, disconnect the cables from the battery.
6. Install the battery as described in this section.

BATTERY (1997-2003 MODELS)

WARNING

Always wear safety glasses when working with batteries. If electrolyte is splashed into the eyes, call a physician immediately, force

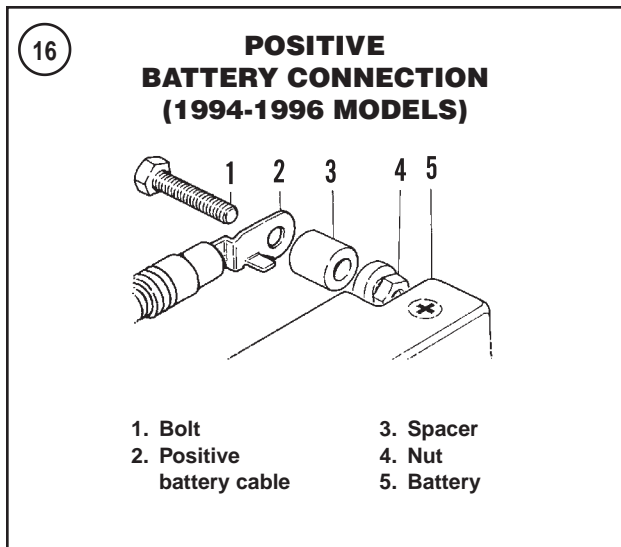

the eyes open and flood with cool, clean water for approximately 15 minutes.

WARNING

When performing the following procedures, protect eyes, skin and clothing.

CAUTION

Be careful not to spill battery electrolyte on painted or polished surfaces. The liquid is

highly corrosive and will damage the finish. If it is spilled, wash it off immediately with soapy water and thoroughly rinse with clean water.

Clean and inspect the battery at periodic intervals. The original equipment battery on 1997-2003 models is a sealed, maintenance-free battery.

On all models in this manual, the negative side is the ground. When removing the battery, disconnect the negative cable first, then the positive cable. This minimizes the chance of a tool shorting to ground when disconnecting the battery positive cable.

Cable Service

To ensure good electrical contact between the battery and the electrical cables, the cables must be clean and free of corrosion.

1. If the electrical cable terminals are corroded, disconnect them from the electrical system.
2. Clean each connector with a wire brush and a baking soda solution. Rinse thoroughly with clean water and wipe dry with a clean cloth.
3. After cleaning, apply a thin layer of dielectric grease to the battery terminals before reattaching the cables.
4. Reconnect the electrical cables to the electrical system if they were disconnected.
5. After connecting the electrical cables, apply a light coat of dielectric grease to the terminals to retard corrosion and decomposition of the terminals.

Removal

1. Remove the seat (Chapter Seventeen).
2. Remove the battery strap (A, **Figure 14**).
3. Remove the battery top cover (B, **Figure 14**).
4. Disconnect the negative battery cable from the battery (A, **Figure 15**).
5. Remove the positive battery cable bolt, positive battery cable and spacer (**Figure 16**).
6. Remove the battery.

Tray

Cleaning and Inspection

1. Inspect the battery tray and cushion (**Figure 17**, typical) for contamination or damage. Clean with a solution of baking soda and water.
2. Check the entire battery case (**Figure 18**) for cracks, warp, discoloration or other damage.
3. Check the battery hold-down strap for acid damage, cracks or other damage. Replace the strap if required.
4. Check the positive battery cable routing connection in the battery tray. Tighten the bolt, if necessary.

5. Check the battery terminal parts for corrosion or damage. Clean parts thoroughly with a solution of baking soda and water. Replace corroded or damaged parts.
6. Clean the top of the battery with a stiff bristle brush using the baking soda and water solution.
7. If necessary, remove the battery tray and clean it. Replace damaged parts.
8. Check the battery cable clamps for corrosion and damage. If corrosion is minor, clean the battery cable clamps with a stiff wire brush. Replace severely worn or damaged cables.

Installation

1. Note the proper routing of the positive battery cable (A, **Figure 15**).
2. Place the battery into the battery tray. Make sure the rubber cushion (**Figure 17**) is installed in the bottom of the tray before installing the battery. Install the battery strap to secure the battery.
3. Install the spacer, positive battery cable and bolt (**Figure 16**). Tighten the bolt securely.

CAUTION

Be sure the battery cables are connected to their proper terminals. Connecting the battery backward will reverse the polarity and damage the rectifier.

4. Install and tighten the negative battery cable (A, **Figure 15**).
5. Coat the battery connections with dielectric grease.
6. Place the top cover (B, **Figure 14**) on the battery.
7. Attach the forward end of the battery strap (A, **Figure 14**) under the front side of the battery tray. Then lay the strap over and into the groove in the battery top. Insert the threaded stud on the rear end of the battery strap into the hole at the rear side of the battery tray. Install the washer and nut. Tighten the nut securely.

Inspection and Testing

The battery electrolyte level cannot be serviced in a maintenance-free battery. Never attempt to remove the sealing bar cap from the top of the battery. The battery does not require periodic electrolyte inspection or water refilling. Refer to any labels (**Figure 19**) on the battery, particularly if an aftermarket battery is installed.

Even though the battery is sealed, protect eyes, skin and clothing. The corrosive electrolyte may have spilled out and can cause severe chemical skin burns and permanent injury. The battery case may be cracked and leaking electrolyte. If electrolyte is spilled or splashed on clothing or skin, immediately neutralize it with a baking soda and water solution, then flush with an abundance of clean water.

1. Remove the battery as described in this chapter. Do not clean the battery while it is mounted in the frame.



2. Set the battery on a stack of newspapers or shop cloths to protect the surface of the workbench.
3. Check the entire battery case for cracks or other damage. If the battery case is warped, discolored or has a raised top, the battery has been overcharged and overheated.
4. Check the battery terminal bolts, spacers and nuts for corrosion or damage. Clean parts thoroughly with a baking soda and water solution. Replace corroded or damaged parts.
5. If the top of the battery is corroded, clean it with a stiff bristle brush using the baking soda and water solution.
6. Check the battery cable ends for corrosion and damage. If corrosion is minor, clean the battery cable ends with a stiff wire brush. Replace worn or damaged cables.
7. Connect a digital voltmeter between the battery negative and positive leads. Note the following:
 - a. If the battery voltage is 13.0-13.2 volts at 68° F (20° C) the battery is fully charged.
 - b. If the battery voltage is 12.0 to 12.5 volts at 68° F (20° C), or lower, the battery is undercharged and requires charging.
8. If the battery is undercharged, recharge it as described in this section. Then test the charging system as described in Chapter Two.
9. Inspect the battery case for contamination or damage. Clean it with a baking soda and water solution.
10. Install the battery as described in this section.

Charging

Refer to the *Initialization* in this section if the battery is new.

To recharge a maintenance-free battery, a digital voltmeter and a charger with an adjustable amperage output are required. If this equipment is not available, have the battery charged by a shop with the proper equipment. Excessive voltage and amperage from an unregulated charger can damage the battery and shorten service life.

The battery should only self-discharge approximately one percent of its given capacity each day. If a battery not in use, without any loads connected, loses its charge within a week after charging, the battery is defective.

If the motorcycle is not used for long periods of time, an automatic battery charger with variable voltage and amperage outputs is recommended for optimum battery service life.

WARNING

During charging, explosive hydrogen gas is released from the battery. Only charge the battery in a well-ventilated area away from open flames, including pilot lights on appliances. Do not allow smoking in the area. Never check the charge of the battery by arcing across the terminals; the resulting spark can ignite the hydrogen gas.

CAUTION

Always disconnect the battery cables from the battery. If the cables are left connected during the charging procedure, the charger may damage the diodes within the voltage regulator/rectifier.

1. Remove the battery from the motorcycle as described in this section.
2. Set the battery on a stack of newspapers or shop cloths to protect the surface of the workbench.
3. Make sure the battery charger is turned off prior to attaching the charger leads to the battery.
4. Connect the positive charger lead to the positive battery terminal and the negative charger lead to the negative battery terminal.
5. Set the charger at 12 volts. If the output of the charger is variable, select the low setting.
6. The charging time depends on the discharged condition of the battery. Refer to **Table 2** for the suggested charging time. Normally, a battery should be charged at 1/10 its given capacity.

CAUTION

If the battery emits an excessive amount of gas during the charging cycle, decrease the charge rate. If the battery becomes hotter than 110° F (43° C) during the charging cycle, turn the charger off and allow the battery to cool. Then continue with a reduced charging rate and continue to monitor the battery temperature.

7. Turn the charger on.
8. After the battery has been charged for the predetermined time, turn off the charger, disconnect the leads and measure the battery voltage. Refer to the following:
 - a. If the battery voltage is 13.0-13.2 volts at 68° F (20° C), the battery is fully charged.
 - b. If the battery voltage is 12.5 volts at 68° F (20° C), or lower, the battery is undercharged and requires additional charging time.
9. If the battery remains stable for one hour, the battery is charged.

10. Install the battery into the motorcycle as described in this section.

Initialization

A new battery must be fully charged before installation. To bring the battery to a full charge, give it an initial charge. Using a new battery without an initial charge will cause permanent battery damage. The battery will never be able to hold more than an 80% charge. Charging a new battery after it has been used will not bring its charge to 100%. When purchasing a new battery, verify its charge status.

NOTE

Recycle the old battery. When a new battery is purchased, turn in the old one for recycling. Most motorcycle dealerships will accept the old battery in trade for a new one. Never place an old battery in the household trash since it is illegal, in most states, to place any acid or lead (heavy metal) contents in landfills.

Load Testing

A load test checks battery performance under full current load and is the best indication of battery condition.

A battery load tester is required for this procedure. When using a load tester, follow the manufacturer's instructions.

1. Remove the battery from the motorcycle as described in this chapter.

NOTE

Let the battery stand for at least one hour after charging prior to performing this test.

2. The battery must be fully charged before beginning this test. If necessary, charge the battery as described in this section.

WARNING

The battery load tester must be turned off prior to connecting or disconnecting the test cables to the battery. Otherwise, a spark could cause the battery to explode.

CAUTION

To prevent battery damage during load testing, do not load test a discharged battery and do not load test the battery for more than 20 seconds. Performing a load test on a discharged battery can cause permanent battery damage.

3. Load test the battery as follows:
 - a. Connect the load tester cables to the battery following the manufacturer's instructions.

- b. Load the battery at 50% of the cold cranking amperage (CCA) or 100 amperes.
- c. After 15 seconds, the voltage reading with the load still applied must be 9.6 volts or higher at 70° F (21° C).
Now quickly remove the load and turn the tester off.
4. If the voltage reading was 9.6 volts or higher, the battery output capacity is good. If the reading was below 9.6 volts, the battery is defective.
5. With the tester off, disconnect the cables from the battery.
6. Install the battery as described in this section.

CHARGING SYSTEM

The charging system consists of the battery, alternator and a voltage regulator/rectifier. Refer to **Figure 20** or **Figure 21**. Alternating current generated by the alternator is rectified to direct current. The voltage regulator maintains the voltage to the battery and additional electrical loads, such as the lights and ignition system, at a constant voltage regardless of variations in engine speed and load.

A malfunction in the charging system generally causes the battery to remain undercharged. To prevent damage to the alternator and the regulator/rectifier when testing and repairing the charging system, note the following precautions:

1. Always disconnect the negative battery cable, as described in this chapter, before removing a component from the charging system.
2. To charge the battery, remove the battery from the motorcycle and recharge it as described in this chapter.
3. Inspect the battery case (**Figure 18**). Look for bulges or cracks in the case, leaking electrolyte or corrosion build-up.
4. Check the charging system wiring for signs of chafing, deterioration or other damage. Refer to the appropriate wiring diagram at the end of this manual.
5. Check the wiring for corroded or loose connections. Clean, tighten or reconnect wiring as required.

Battery Current Draw Test

This test measures the current draw, or drain, on the battery when all electrical systems and accessories are off. Perform this test if the battery will not hold a charge when the motorcycle is not being used. Maximum current draw should be less than 3.0 mA. The battery must be fully charged to perform this test.

1. Disconnect the negative battery cable as described in this chapter.
2. Connect an ammeter between the negative battery cable end and the negative battery terminal as shown in **Figure 22**.
3. With the ignition switch, lights and all accessories turned off, read the ammeter. If the current drain exceeds 3.0 mA, continue with Step 4.
4. Refer to the appropriate wiring diagram at the end of this manual. Check the charging system wires and connectors for shorts or other damage.

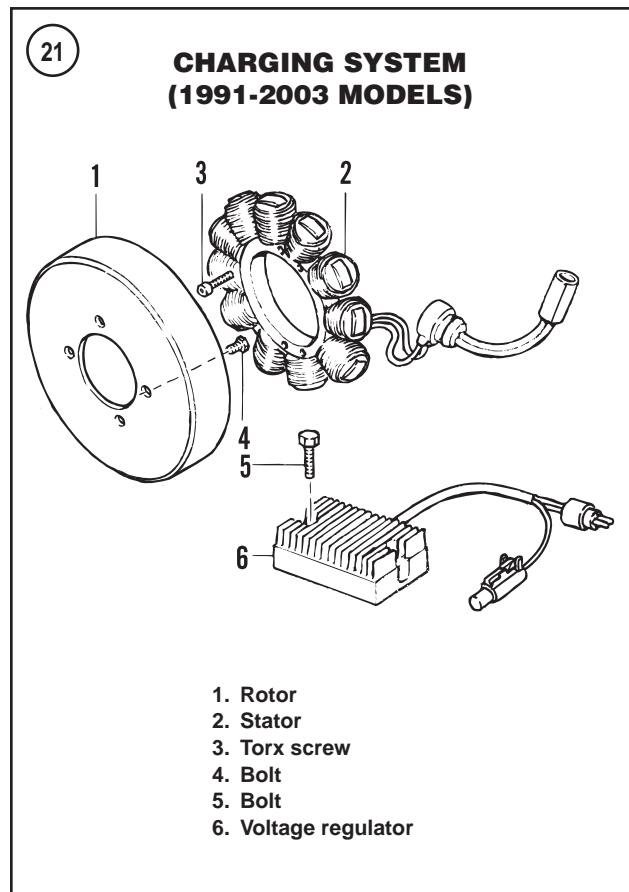
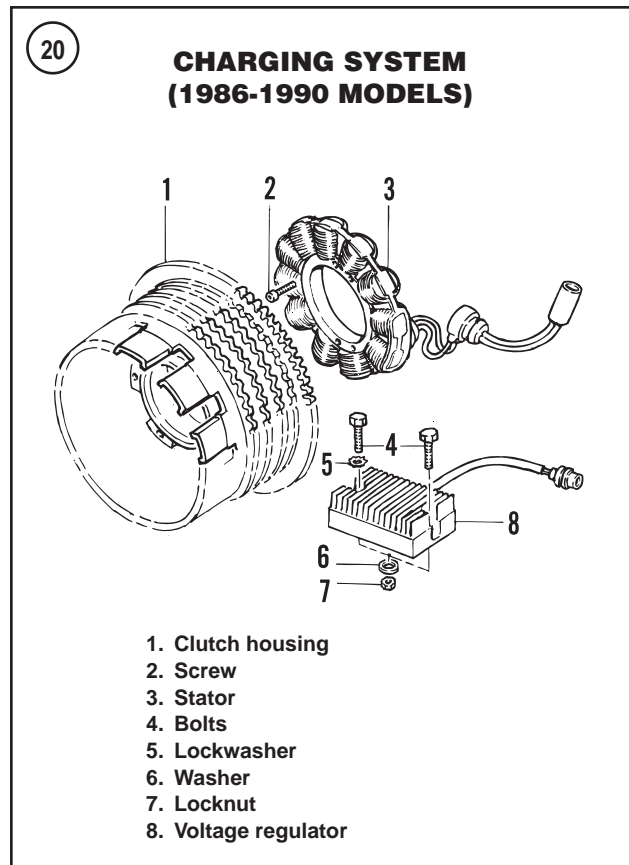

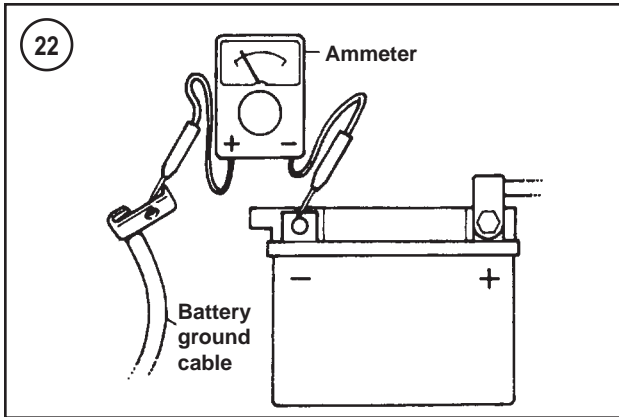

the visual inspection proves satisfactory, test the charging system as described in *Charging System* in Chapter Two.

1. Make sure the battery cables are connected properly. If polarity is reversed, check for a damaged voltage regulator/rectifier.
2. Inspect the terminals for loose or corroded connections. Tighten or clean them as required.
3. Inspect the battery case. Look for bulges or cracks in the case, leaking electrolyte or corrosion buildup.
4. Check all connections at the alternator to make sure they are clean and tight.
5. Check the circuit wiring for corroded or loose connections. Clean, tighten or connect wiring as required.



5. Unplug each electrical connector separately and check for a reduction in the current draw. If the meter reading changes after a connector is disconnected, the source of the current draw has been found. Check the electrical connectors carefully before testing the individual component.
6. After completing the test, disconnect the ammeter and reconnect the negative battery cable.

Testing

A malfunction in the charging system generally causes the battery to remain undercharged. Perform the following visual inspection to determine the cause of the problem. If

ALTERNATOR (1986-1990 MODELS)

The alternator rotor and stator on 1986-1990 models are located behind the clutch.

Rotor Removal/Installation

Refer to **Figure 20**.

1. Remove the clutch as described in Chapter Six.

NOTE

Do not disassemble the clutch assembly.

2. Turn the clutch assembly upside down and place it on the workbench.

NOTE

Because a portion of the clutch shell operates as the alternator rotor, removal of the clutch shell may prove difficult due to the magnetic pull of the rotor magnets.

3. Remove the rotor circlip (**Figure 23**). Then remove the rotor/clutch shell assembly (**Figure 24**) from the clutch hub.
4. If necessary, replace the rotor/clutch shell as a single unit.

CAUTION

Inspect the inside of the rotor for small bolts, washers or other metal debris that may have been picked up by the magnets. These small metal bits can cause severe damage to the alternator stator assembly.

5. Reassemble the new rotor/clutch shell assembly. Secure it with a new circlip (**Figure 23**).
6. Install the clutch as described in Chapter Six.

Stator Removal/Installation

A T-27 Torx socket is required for this procedure.

1. Disconnect the stator electrical connector below the crankcase on the left side.
2. Remove the clutch as described in Chapter Six.

NOTE

Do not disassemble the clutch.

3. Remove the four Torx screws securing the stator (**Figure 25**) to the transmission access cover. Discard the Torx screws.
4. Remove the stator by prying the stator wire grommet (**Figure 26**) out of the crankcase and remove the wire/connector together with the stator. Note the path of the wire through the crankcase and the to the connector of the wiring harness.
5. Installation is the reverse of these steps, noting the following:

- a. When routing the new stator wire and connector, route it between the frame and rear engine gap. Press the grommet fully into the crankcase opening.

CAUTION

Use new Torx screws. The thread locking compound originally applied to the Torx screws is sufficient for one-time use only. A loose Torx screw could back out and cause alternator damage.

- b. Install new Torx screws and tighten to 30-40 in.-lb. (3-4.5 N•m).
- c. Install the clutch assembly as described in Chapter Six.

Voltage Regulator Removal/Installation

The voltage regulator is mounted on the front frame downtubes (**Figure 27**).

The voltage regulator must be serviced as a unit assembly. It cannot be rebuilt.

1. Remove the seat (Chapter Seventeen).
2. Disconnect the voltage regulator wiring connector below the crankcase on the left side.
3. Remove any wiring retaining straps.
4. Disconnect the voltage regulator connector from the main circuit breaker.
5. Remove the voltage regulator mounting screws and remove the voltage regulator (**Figure 27**).
6. Reverse the removal steps to install the voltage regulator.

ALTERNATOR (1991-2003 MODELS)

The alternator rotor and stator on 1991-2003 models are located behind the engine sprocket.

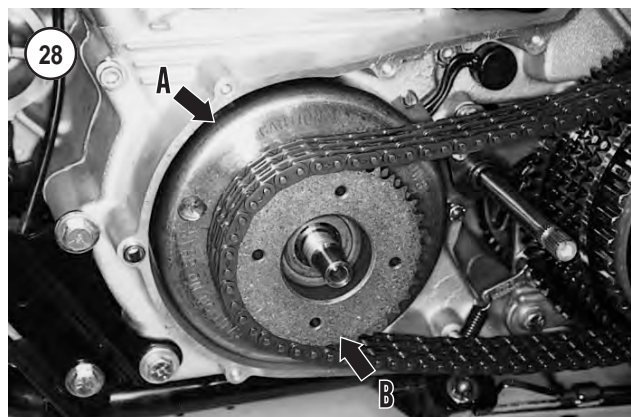
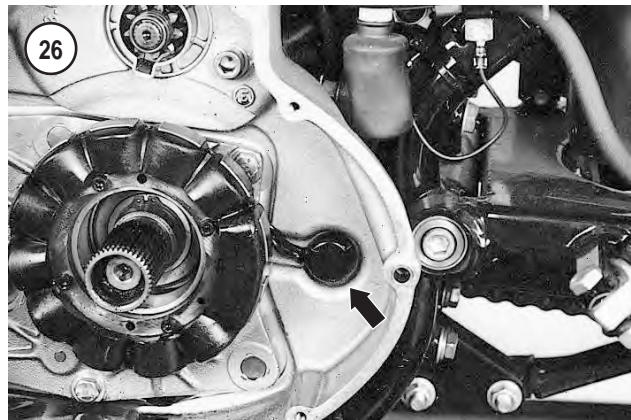
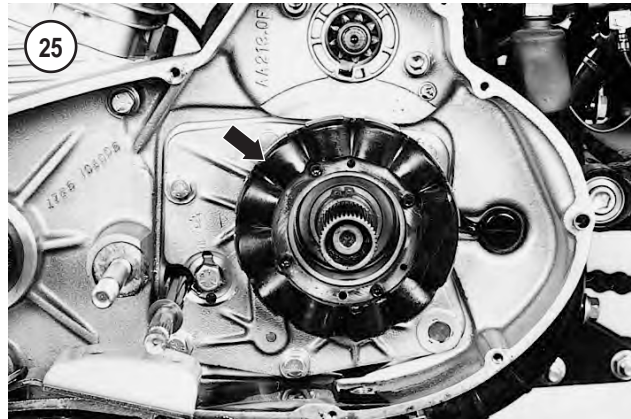

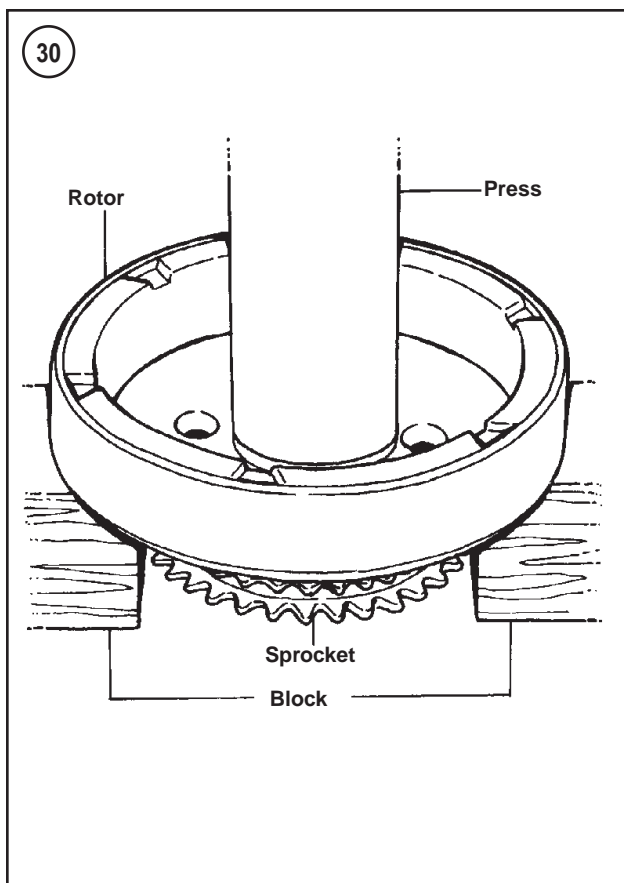

Rotor Removal/Installation

The rotor (A, **Figure 28**) is mounted on the engine sprocket (B).

1. Disconnect the negative battery cable as described in this chapter.
2. Remove the primary chain, engine sprocket and clutch (Chapter Seven).
3. If necessary, press the engine sprocket off of the rotor as described in this chapter.

CAUTION

Inspect the inside of the rotor for small bolts, washers or other metal debris that may have been picked up by the magnets. These small metal bits can cause severe damage to the alternator stator assembly.

4. Install the primary chain, engine sprocket and clutch as described in Chapter Seven.

Rotor Disassembly/Reassembly

1. Remove the rotor-to-engine sprocket mounting bolts (**Figure 29**).
2. Support the rotor in a press as shown in **Figure 30**. Press the engine sprocket off the rotor.
3. Clean the engine sprocket, rotor and mounting bolts in solvent and dry thoroughly. Remove any threadlock residue from the sprocket and mounting bolt threads.
4. Place the rotor on top of the sprocket, aligning the holes in the rotor with the threaded holes in the sprocket.
5. Apply threadlock (Loctite 243 or equivalent) to the mounting bolts prior to installation. Install the bolts fingertight.
6. Support the sprocket in a press and place a piece of pipe between the rotor and press ram. Press the rotor onto the sprocket (**Figure 30**).
7. Tighten the rotor-to-engine sprocket mounting bolts to 90-110 in.-lb. (10-12 N•m).

Rotor Inspection

1. Check the rotor (**Figure 31**) for cracks or breaks.

WARNING

Replace a cracked or chipped rotor. A damaged rotor may fly apart at high rpm, throwing metal fragments into the engine. Do not attempt to repair a damaged rotor.

2. Check the rotor magnets for damage or looseness.
3. Replace the rotor, if necessary, as described in this section.

Stator

Removal/Installation

The stator (**Figure 32**) is mounted behind the rotor and bolted to the left crankcase.

1. Remove the rotor as described in this section.
2. On a piece of paper, draw a diagram of the stator wiring harness frame routing path prior to removing the stator.
3. Disconnect the electrical connector from the stator lead (**Figure 33**, typical).
4. Remove the cable retaining plate (**Figure 34**).
5. Remove the stator plate Torx screws (**Figure 35**). Discard the Torx screws.
6. Remove the stator wiring grommet from the crankcase.
7. Remove the stator assembly and its attached wiring harness (**Figure 36**).
8. Inspect the stator wires (**Figure 37**) for fraying or damage. Check the stator connector pins for looseness or damage. Replace the stator if necessary.
9. Installation is the reverse of the preceding removal steps while noting the following.
 - a. Lightly coat the stator wiring grommet with engine oil. Then insert the grommet (**Figure 38**) into the crankcase.

CAUTION

New Torx screws must be used. The thread locking compound originally applied to the Torx screws is sufficient for one-time use only. A loose Torx screw could back out and cause alternator damage.

- b. Install new stator Torx screws and tighten to 30-40 in.-lb. (3-4.5 N•m).

CAUTION

When bringing the wiring harness out from underneath the gearcase cover, the harness should be routed 1 1/2 in. (38 mm) forward of the rear gearcase edge. This distance is necessary to prevent the secondary drive belt or sprocket from damaging the wiring harness.

- c. Following the routing diagram notes, route the stator wiring harness along the frame. Secure the harness with the proper cable straps.
- d. Install the rotor as described in this section.

Voltage Regulator

Removal/Installation

The voltage regulator is mounted on the front frame downtubes. See **Figure 39** (1991-1993 models) or **Figure 40** (1994-2003 models).

The voltage regulator cannot be rebuilt; if damaged it must be replaced.



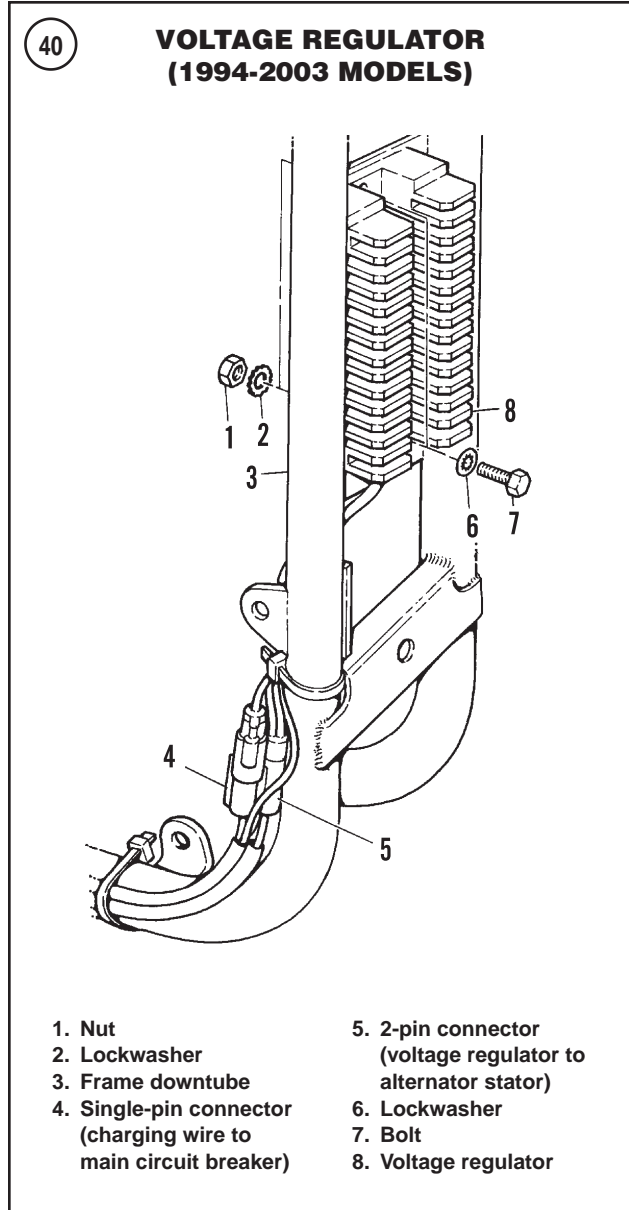

1. Disconnect the negative battery cable as described in this chapter.

2. Note the voltage regulator wiring harness frame routing path prior to removing the voltage regulator.

3A. On 1991-1993 models, perform the following:

- a. Disconnect the voltage regulator-to-stator 2-pin wiring connector (**Figure 33**, typical).
- b. Disconnect the voltage regulator-to-circuit breaker black wiring lead. This connector is mounted underneath the seat.

3B. On 1994-2003 models, perform the following:

- a. Disconnect the voltage regulator-to-circuit breaker 2-pin wiring connector.
- b. Disconnect the voltage regulator-to-50 amp single-pin Deutsch wiring connector (**Figure 40**).

41

IGNITION SYSTEM (1986-1993 MODELS)

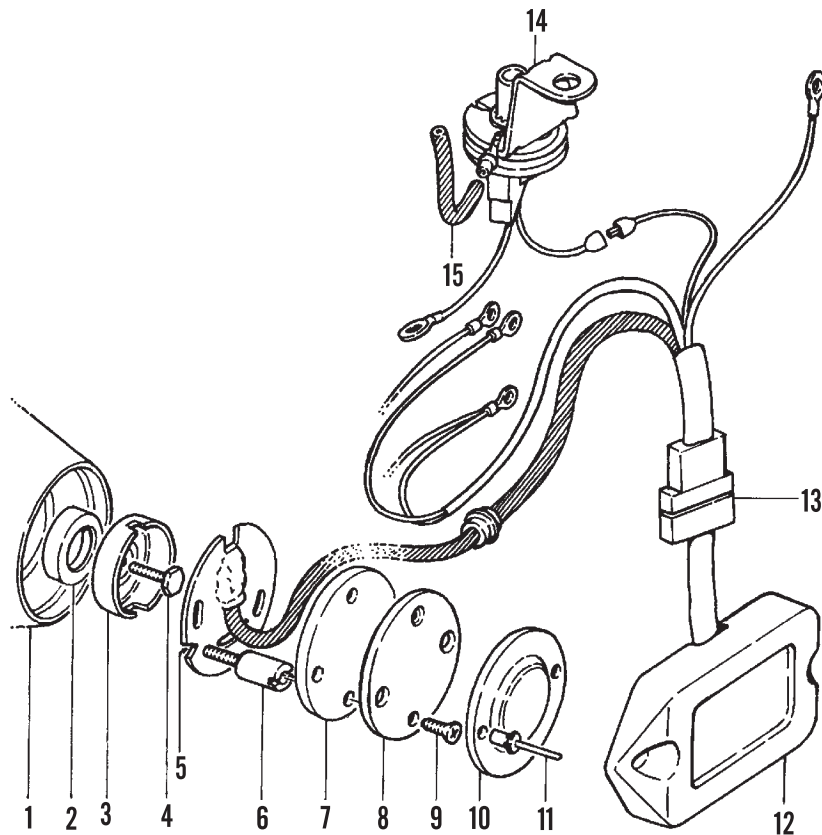

- | | |
|-----------------------|---------------------|
| 1. Gearcase cover | 9. Screw |
| 2. Oil seal | 10. Outer cover |
| 3. Rotor | 11. Rivet |
| 4. Bolt | 12. Ignition module |
| 5. Sensor plate | 13. Connector |
| 6. Sensor plate screw | 14. VOES |
| 7. Gasket | 15. Vacuum hose |
| 8. Inner timer cover | |

4. Disconnect and remove the cable straps securing the voltage regulator wiring harness to the frame. Pull the wiring harness away from the frame.

5. Remove the voltage regulator mounting fasteners and remove the voltage regulator.

6. Install by reversing the removal steps.

IGNITION SYSTEM (1986-1997 MODELS)

The ignition system consists of a single ignition coil, two spark plugs, inductive pickup unit, ignition module and a vacuum operated electric switch (VOES). This system has

a full electronic advance. The inductive pickup unit is driven by the engine and generates pulses which are routed to the solid-state ignition control module. This control module computes the ignition timing advance and ignition coil dwell time eliminating the need for mechanical advance and routine ignition service.

The VOES senses intake manifold vacuum through a carburetor body opening. The switch is open when the engine is in low vacuum situations such as acceleration and high load. The switch is closed when engine vacuum is high such as during a low engine load condition. The VOES allows the ignition system to follow two spark advance curves. A maximum spark curve can be used during a

42

IGNITION SYSTEM (1994-1997 MODELS)

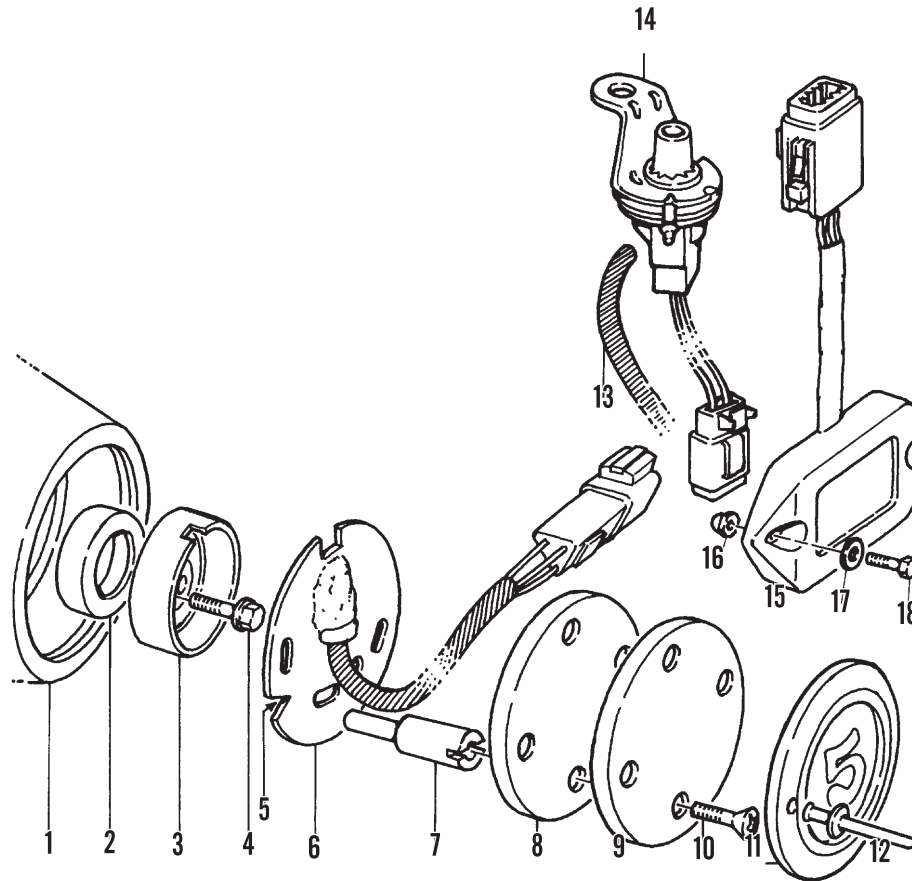

- | | |
|------------------------------|---------------------|
| 1. Gearcase cover | 10. Screw |
| 2. Oil seal | 11. Outer cover |
| 3. Rotor | 12. Rivet |
| 4. Bolt | 13. Vacuum-hose |
| 5. Adjusting notch | 14. VOES |
| 6. Sensor plate | 15. Ignition module |
| 7. Sensor plate screw | 16. Locknut |
| 8. Gasket (1994-1996 models) | 17. Washer |
| 9. Inner timer cover | 18. Bolt |

high-vacuum condition to provide improved fuel economy and performance. During low vacuum conditions, the spark can be retarded to minimize ignition knock and still maintain performance.

The timing sensor is triggered by the leading and trailing edges of the two rotor slots. As rpm increases, the control module steps the timing in three stages of advance.

Sensor Plate Removal/Installation

Refer to **Figure 41** or **Figure 42**.

1. Disconnect the negative battery cable as described in this chapter.

NOTE

On 1991-1997 models, the sensor plate wiring harness connector must be removed from the end of the wiring harness prior to removing the wiring harness through the gearcase cover.

2. On 1991-1997 models, disconnect the sensor plate wiring harness connector. Then remove the connector from the wiring harness as follows:
 - a. Note the position of each sensor plate wiring terminal in the end of the connector.



- b. On 1991-1993 models, remove the terminals from the end of the connector using the Cannon Connector Tool No. 201051.
- c. On 1994-1997 models, remove the terminals from the end of the connector as described in *Electrical Connector* in this chapter.

3. Drill out the outer cover rivets (**Figure 43**) with a 3/8 in. drill bit.

4. Using a punch, tap the rivets through the outer cover (**Figure 44**) and remove the outer cover.

5. Using a punch, tap the rivets through the inner cover.

6. Remove the inner cover screws (**Figure 45**) and remove the cover and gasket (**Figure 46**).

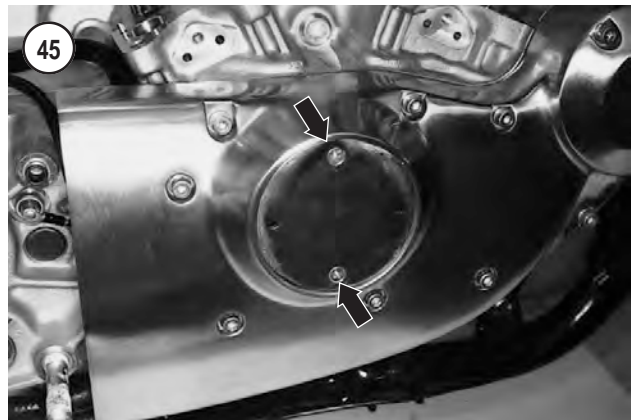

7. To help approximate ignition timing when installing the sensor plate, mark an alignment mark of the sensor plate mounting screws position on the sensor plate.

8. Remove the screws (**Figure 47**) securing the sensor plate to the crankcase and pull the sensor plate out of the gearcase cover.



9. Withdraw the sensor plate wiring harness through the crankcase hole and remove the sensor plate.

10. Remove the rotor bolt (A, **Figure 48**) and rotor (B).

11. Installation is the reverse of the preceding steps while noting the following.

12. To install the rotor:

- a. Align the tab on the back of the rotor (**Figure 49**) with the notch in the end of the crankshaft (A, **Figure 50**).
- b. Apply threadlock (Loctite 242 or equivalent) to the rotor bolt (A, **Figure 48**) and tighten it to 43-53 in.-lb. (5-6 N•m).

CAUTION

Route the sensor plate wires approximately 1 1/2 in. (38 mm) forward of the gearcase rear edge. Wires routed farther to the rear may allow the wiring harness to contact the secondary drive chain/belt and or sprocket, damaging the wiring harness.

13. Insert the sensor plate wires through the gearcase cover and route the wiring harness along the original harness path noted during removal.



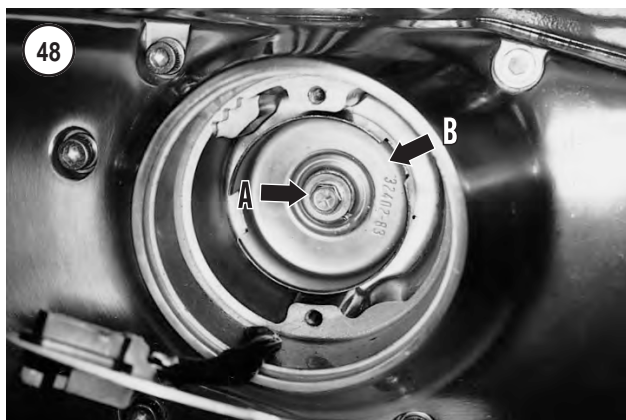

14. Before riveting the cover in place, check the ignition timing as described in Chapter Three.

CAUTION

Be sure to use the correct rivets when installing the inner and outer covers. These are timing cover rivets which do not have ends that will fall into the timing compartment and damage the ignition components.

15. Rivet the outer cover to the inner cover. Only use original equipment rivets (part No. 8699) to secure the outer cover. See **Figure 51** and **Figure 43**.



Inspection

1. If necessary, refer to Chapter Two for troubleshooting.
2. Check the ignition compartment for oil leaks. If present, remove the gearcase oil seal (B, **Figure 50**) by prying it out with a screwdriver or seal remover. Install a new seal by tapping it in place with a suitable size socket placed on the outside of the seal. Drive the seal into position so it is flush with the seal bore surface. If the gearcase oil seal is not seated properly, it will leak.

Ignition Module Removal/Installation

The ignition module (**Figure 52**) is mounted on the left side of the motorcycle to the rear of the battery.

1. Disconnect the negative battery cable as described in this chapter.
2. Remove the ignition module cover.
- 3A. On 1986-1994 models, disconnect the ignition module wires from the ignition coil. Remove the ground wire connection at the frame.
- 3B. On 1995-1997 models, disconnect the ignition module connector from the wiring harness.
4. Remove the ignition module assembly (**Figure 52**).
5. Install by reversing the preceding steps. On 1995-1997 models, tighten the ignition module bolts to 15-20 in.-lb. (1.5-2 N•m).

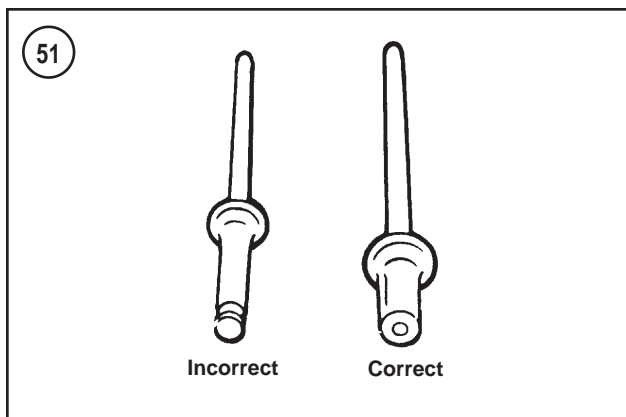

Vacuum-Operated Electric Switch (VOES)

Refer to **Figure 53**.

Removal/installation (1986-1993 models)

1. Remove the air filter backplate as described in Chapter Ten or Chapter Eleven.
2. Remove the rear fuel tank mounting bolt.
3. Raise the rear of the fuel tank and disconnect the VOES wire from the ignition module. Remove the VOES cable strap.
4. Disconnect the vacuum hose from the VOES.
5. Remove the VOES ground wire bolt, washers and locknut.
6. Remove the VOES mounting bracket fastener and remove the VOES from the top center engine mount bracket.

CAUTION

Make sure the VOES and its ground wire do not contact the engine rocker box. Engine vibration and heat can damage the switch and/or ground wire.

7. Install by reversing the preceding steps while noting the following:
 - a. On 1986-1990 models, tighten the VOES mounting bracket bolt to 20 ft.-lb. (27 N•m).
 - b. On 1991-1993 models, tighten the VOES mounting bracket locknut to 60-144 in.-lb. (7-16 N•m).
 - c. On 1986-1993 models, tighten the VOES ground wire bolt and locknut to 25-30 ft.-lb. (34-41 N•m).

Removal/installation (1994-1997 models)

1. Remove the air filter backplate as described in Chapter Eleven.
2. Remove the rear fuel tank mounting bolt.
3. Raise the rear of the fuel tank and push the two-pin Deutsch connector mounted on the top motor mount rearward to unsnap it from the T-stud clip.
4. Disconnect the 2-pin Deutsch connectors.
5. Remove the rubber cap mounted on the stud at the back of the top center engine mount. Loosen, then remove the locknut to free the VOES mounting bracket.

CAUTION

Make sure the VOES and its ground wire do not contact the engine rocker box. Engine vibration and heat can damage the switch and/or ground wire.

6. Pull the VOES out and disconnect the vacuum hose from the VOES.
7. Install by reversing the preceding steps while tightening the VOES mounting bracket locknut to 60-144 in.-lb. (7-16 N•m).

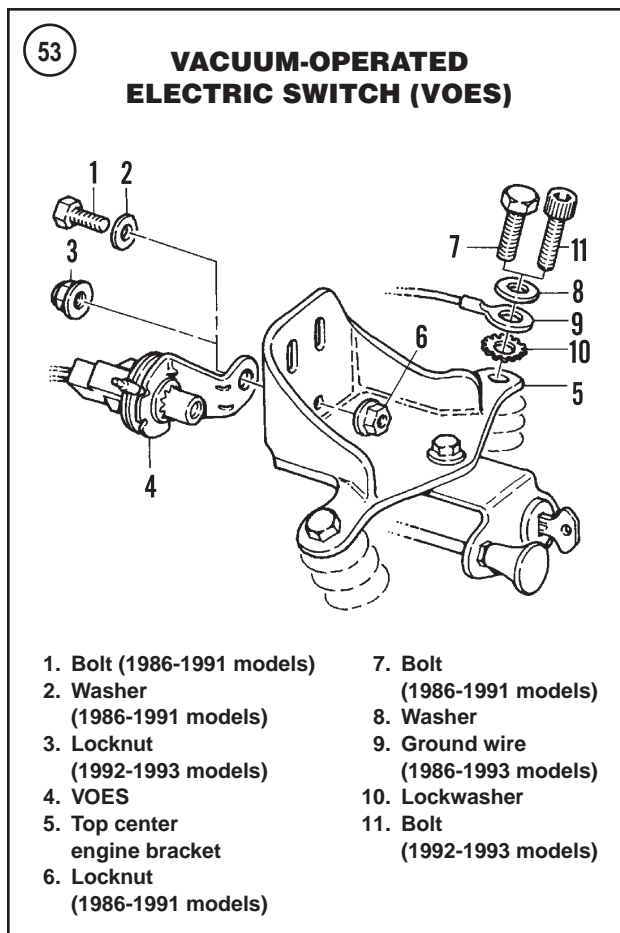

Bench test

NOTE

*The VOES can be tested with a timing light while mounted on the motorcycle. Refer to **Ignition Timing Adjustment** in Chapter Three.*

1. Remove the VOES as described in this section.
2. Connect an ohmmeter to the two VOES electrical leads (1986-1993) or socket terminals (1994-1997).
3. Connect a hand-operated vacuum pump to the VOES vacuum fitting.
4. Slowly operate the vacuum pump handle while reading the vacuum gauge and ohmmeter. The ohmmeter should read 0 ohms with a vacuum reading of 3.5-4.5 in./Hg (89-114 mm/Hg).
5. If the vacuum reading falls outside the specified range when the ohmmeter reads 0 ohms, the VOES switch is faulty and must be replaced.

IGNITION SYSTEM (ALL 1998-2003 MODELS, EXCEPT 1200S MODELS)

The ignition system consists of a single ignition coil, two spark plugs, ignition module, a vacuum operated electric switch (VOES), a bank angle sensor and the rotor. This system has an electronically controlled advance. The solid-state

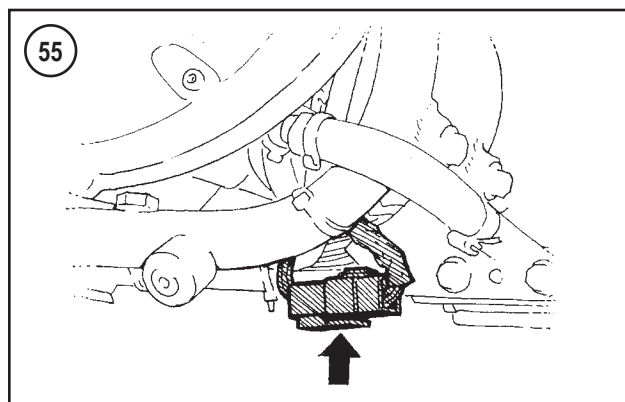
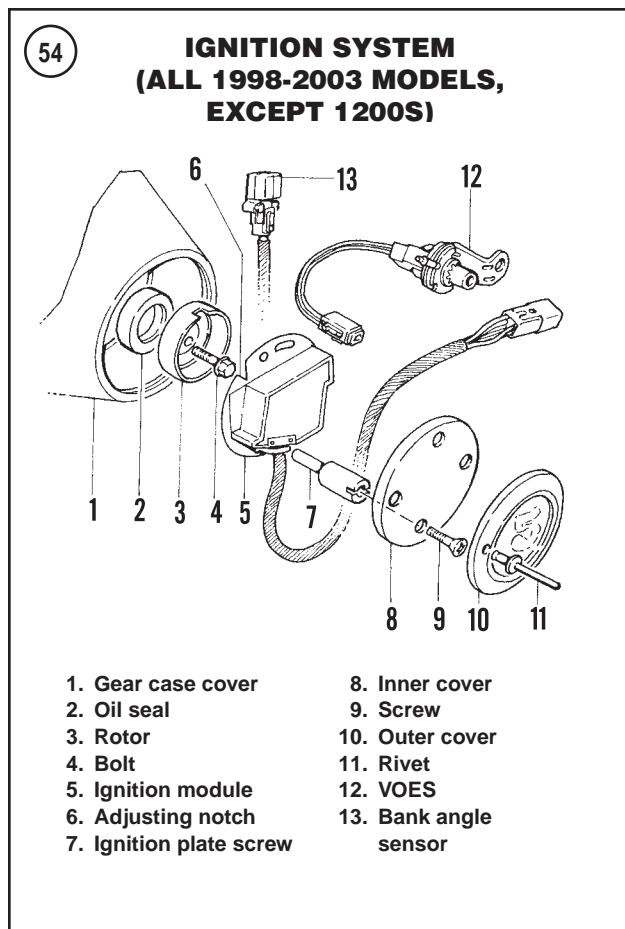

ignition control module is mounted in the gearcase cover. The cam position sensor and timing plate are integral parts of the ignition module. The ignition module controls the ignition timing advance and ignition coil dwell time, eliminating the need for mechanical advance and routine ignition service.

The VOES senses intake manifold vacuum at the carburetor. The switch is open when the engine is in low vacuum situations, such as acceleration and high load. The switch is closed when engine vacuum is high such as during a low engine load condition. The VOES allows the ignition system to follow two spark advance curves. A maximum spark



curve can be used during a high-vacuum condition to provide improved fuel economy and performance. During low vacuum conditions, the spark can be retarded to minimize ignition knock and still maintain performance.

The leading and trailing edges of the two rotor slots trigger the timing sensor. As engine speed increases, the control module advances the timing in three stages.

The bank angle sensor is a normally-closed magnetic switch. It is secured to the side of the battery tray. If the motorcycle lean angle exceeds 55°, the sensor opens the circuit. The ignition module detects this open circuit and turns off the ignition system. Once the sensor is activated, the motorcycle must be returned to vertical and the ignition turned off then on. Then, the ignition system is operational and the engine can be restarted.

Refer to **Figure 54**.

Ignition Module Removal/Installation

1. Disconnect the negative battery cable as described in this chapter.

NOTE

The ignition module terminal pins must be removed from the ignition module connector prior to removing the wiring through the gearcase cover.

2. Disconnect the ignition module connector (**Figure 55**) from the wiring harness. Remove the terminal pins from the connector as follows:
 - a. Record the position of each ignition module wiring terminal in the end of the connector.
 - b. Remove the terminals from the end of the connector as described in *Electrical Connector* in this chapter.
3. Drill out the outer cover rivets using a 3/8 in. drill bit.
4. Using a punch, tap the rivets through the outer cover (**Figure 56**) and remove the outer cover.
5. Using a punch, tap the rivets through the inner cover.
6. Remove the inner cover screws (**Figure 57**), then remove the cover.

7. To help approximate ignition timing when installing the ignition module, mark the position of the mounting screws on the ignition module timing plate.
8. Remove the screws (**Figure 58**) securing the ignition module to the crankcase and pull the ignition module out of the gearcase cover.
9. Note the routing of the wires. Withdraw the ignition module wiring through the crankcase hole and remove the module.
10. Remove the rotor bolt (A, **Figure 59**) and rotor (B).
11. To install the rotor:
 - a. Align the tab on the back of the rotor (**Figure 60**) with the notch in the end of the crankshaft (A, **Figure 61**).
 - b. Apply threadlock (Loctite 242 or equivalent) to the rotor bolt (A, **Figure 59**) and tighten it to 43-53 in.-lb. (5-6 N•m).

CAUTION

Route the ignition module wires approximately 1 1/2 in. (38 mm) forward of the gearcase rear edge. Wires routed farther to the rear may allow the wiring harness to contact the secondary drive chain/belt and or sprocket, damaging the wiring harness.

12. Insert the ignition module wires through the gearcase cover and route the wiring harness along the noted during removal path.
13. Before riveting the cover in place, check the ignition timing as described in Chapter Three.

CAUTION

Be sure to use the correct rivets to install the outer cover to the inner cover. These are timing cover rivets that do not have ends that will fall into the timing compartment and damage the ignition components.

14. Rivet the outer cover to the inner cover. Use only original equipment rivets (part No. 8699) to secure the outer cover. See **Figure 62**.

Inspection

1. If necessary, refer to Chapter Two for troubleshooting.
2. Check the ignition compartment for oil leaks. If present, remove the gearcase seal (B, **Figure 61**) by prying it out with a screwdriver or seal remover. Install a new seal by tapping it in place with a suitable size driver placed on the outside of the seal. Drive the seal in position so it is flush with the seal bore surface. If the gearcase oil seal is not seated properly, it will leak.

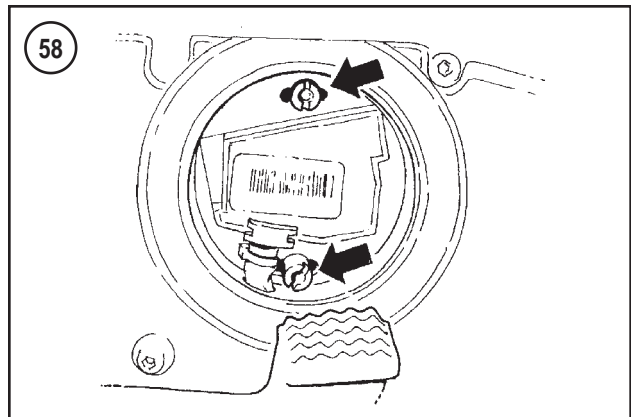
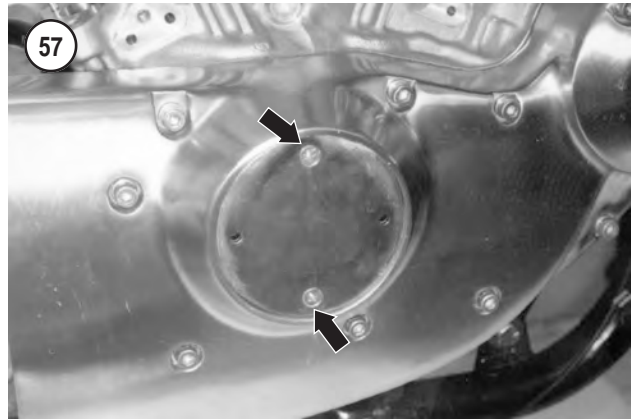

Vacuum-Operated Electric Switch (VOES)

For service information concerning bench testing and replacement of the VOES refer to 1994-1997 model information in *Ignition System (1986-1997 Models)* in this chapter.

IGNITION SYSTEM (1998-2003 1200S MODELS)

The ignition system consists of a single ignition coil, four spark plugs, inductive pickup unit, ignition control module, a manifold absolute pressure (MAP) sensor and bank angle sensor. The inductive pickup unit is driven by the engine and generates pulses, which are routed to the solid-state ig-

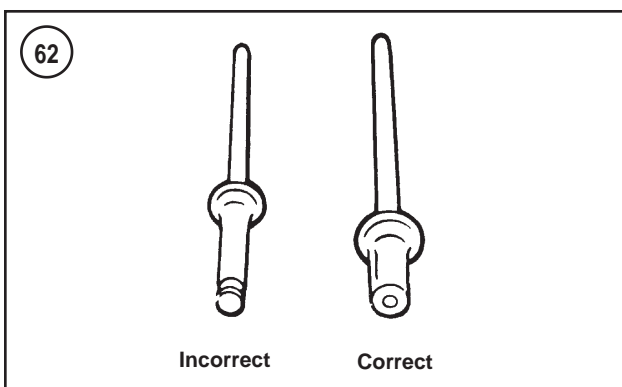
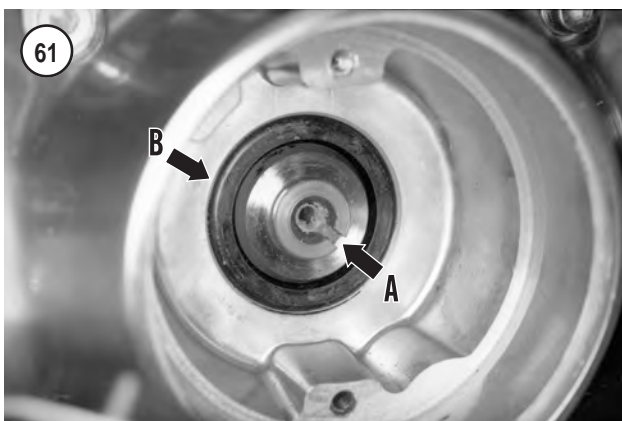

nitron control module. This ignition module, which is mounted under the seat, determines the ignition timing advance and ignition coil dwell time, eliminating the need for mechanical advance and routine ignition service.

The MAP sensor is mounted on the frame backbone under the fuel tank. This sensor monitors intake manifold vacuum and adjusts the ignition advance for maximum performance.

The timing sensor is triggered by the leading and trailing edges of the two rotor slots. As engine speed increases, the control module adjusts the timing in three stages of advance.

The bank angle sensor is a normally closed magnetic switch. It is secured to the side of the battery tray. If the motorcycle lean angle exceeds 55°, the magnet in the sensor moves and opens the circuit. The ignition control module

detects this open circuit and turns off the ignition system. Once the sensor is activated, the motorcycle must be returned to vertical and the ignition turned off then on. Then, the ignition system is operational and the engine can be re-started.

The ignition system components are shown in **Figure 63**.

Sensor Plate Removal/Installation

Refer to **Figure 63**.

1. Disconnect the negative battery cable as described in this chapter.

NOTE

The terminal pins must be removed from sensor plate connector before removing the wiring through the gearcase cover.

2. Disconnect the sensor plate connector from the wiring harness. Then remove the terminal pins from the connector as follows:

- a. Record the position of each sensor plate terminal pin in the end of the connector.
- b. Remove the terminal pins from the connector as described in *Electrical Connector* in this chapter.

3. Drill out the outer cover rivets with a 3/8 in. drill bit.

4. Using a punch, tap the rivets through the outer cover (**Figure 56**) and remove the outer cover.

5. Using a punch, tap the rivets through the inner cover.

6. Remove the inner cover screws (**Figure 57**) and remove the cover.

7. To help approximate ignition timing when installing the sensor plate, mark the position of the sensor-plate mounting screws on the sensor plate.

8. Remove the screws (**Figure 64**) securing the sensor plate to the crankcase and pull the sensor plate out of the gearcase cover.

9. Withdraw the sensor plate wiring harness through the crankcase hole and remove the sensor plate. Note the routing of the wires.

10. Remove the rotor bolt (A, **Figure 59**) and rotor (B).

11. To install the rotor:

- a. Align the tab on the back of the rotor (**Figure 60**) with the notch in the end of the crankshaft (A, **Figure 61**).
- b. Apply threadlock (Loctite 242 or equivalent) to the rotor bolt and tighten it to 43-53 in.-lb. (5-6 N•m).

CAUTION

Route the sensor plate wires approximately 1 1/2 in. (38 mm) forward of the gearcase rear edge. Wires routed farther to the rear may allow the wiring harness to contact the secondary drive chain/belt and or sprocket, damaging the wiring harness.

12. Insert the sensor plate wires through the gearcase cover and route the wiring harness along its original path.

63

IGNITION SYSTEM (1998-2003 1200S MODELS)

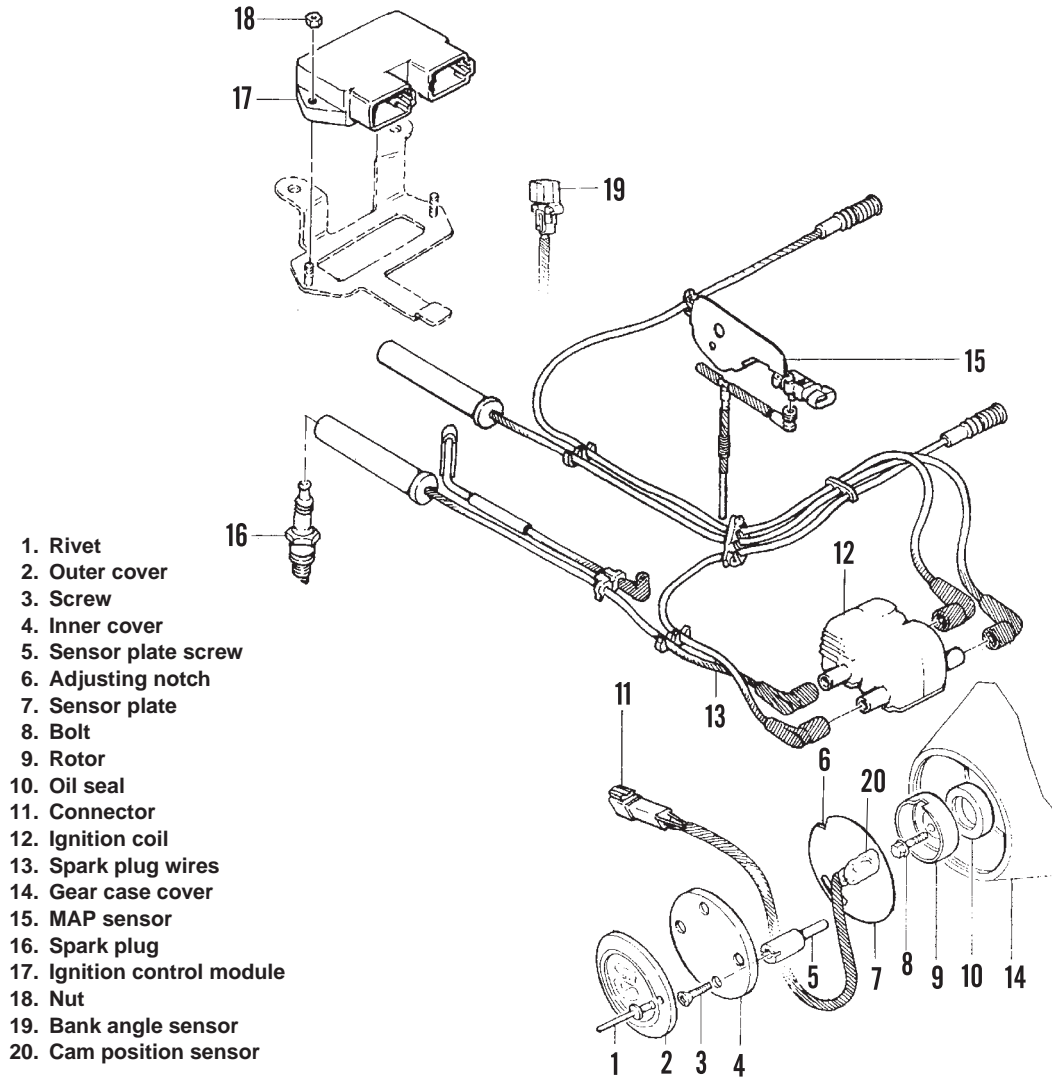

13. Before riveting the cover in place, check the ignition timing as described in Chapter Three.

CAUTION

Be sure to use the correct rivets to install the outer cover to the inner cover. These are special timing cover rivets that do not have ends that will fall into the timing compartment and damage the ignition components.

14. Rivet the outer cover to the inner cover. Use only original equipment rivets (part No. 8699) to secure the outer cover. See **Figure 62**.



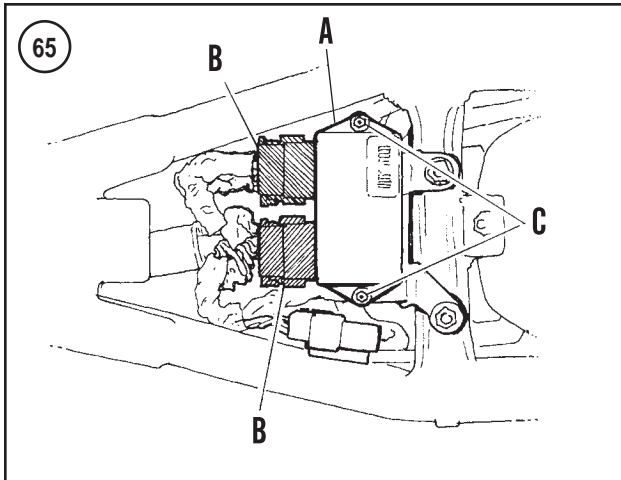

Ignition Control Module Removal/Installation

The ignition control module (A, **Figure 65**) is mounted under the seat.

1. Disconnect the negative battery cable as described in this chapter.
2. Remove the seat (Chapter Seventeen).
3. Disconnect the two harness connectors (B, **Figure 65**) from the ignition control module.
4. Remove the two mounting bolts (C, **Figure 65**) and remove the ignition module from the mounting bracket.
5. Install by reversing the removal steps. Tighten the ignition module mounting bolts to 15-21 in.-lb. (1.7-2.4 N•m).

IGNITION COIL

CAUTION

When replacing an ignition coil, make sure the coil is marked *ELECTRONIC ADVANCE*. Installing an older type ignition coil could damage electronic ignition components.

Ignition Coil Testing

Refer to Chapter Two.

Removal/Installation

(All Models Except 1200S Models)

The ignition coil is mounted below the fuel tank.

1. Disconnect the negative battery cable as described in this chapter.

NOTE

Label all wiring connectors prior to disconnecting them.

2. Disconnect the spark plug cables (A, **Figure 66**) from the ignition coil.
3. Disconnect the ring terminal wires (B, **Figure 66**) from the ignition coil.
4. Remove the ignition coil mounting bolts and nutplate (A, **Figure 67**) and rest the ignition coil (B) on top of the cylinder head cover.
5. Remove the ignition coil.
6. Installation is the reverse of the preceding steps. Tighten the coil mounting bolts to 24-72 in.-lb. (3-8 N•m).

Removal/Installation (1200S Models)

The ignition coil is mounted below the fuel tank.

1. Disconnect the negative battery cable as described in this chapter.

NOTE

Label all wiring connectors prior to disconnecting them.

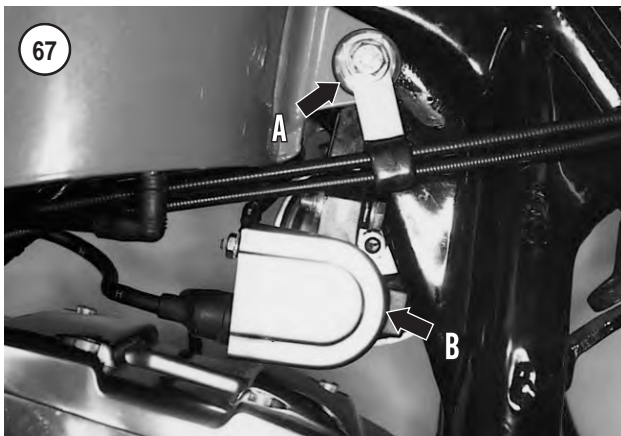
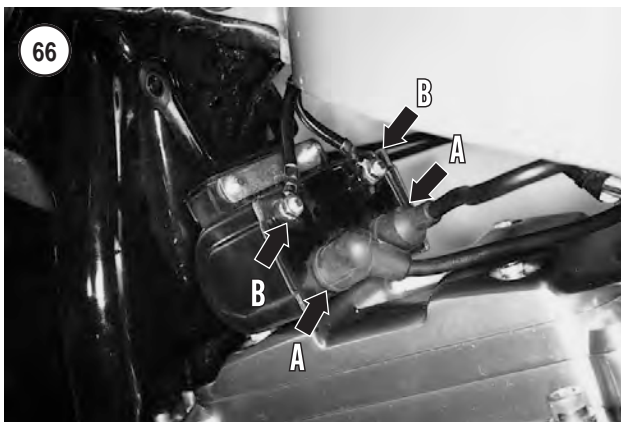

Inspection

1. If necessary, follow the procedures in Chapter Two to troubleshoot the ignition system.
2. Check the ignition compartment for oil leaks. If present, remove the gearcase seal (B, **Figure 61**) by prying it out with a screwdriver or seal remover. Install a new seal by tapping it in place with a suitable driver placed on the outside of the seal. Drive the seal in position so it is flush with the seal bore surface. If the gearcase oil seal is not seated properly, it will leak.

2. Disconnect the four spark plug cables (A, **Figure 68**) from the ignition coil.
3. Disconnect the harness connector (B, **Figure 68**) from the ignition coil.
4. Remove the ignition coil mounting bolt (C, **Figure 68**) and remove the coil.
5. Installation is the reverse of removal while noting the following:
 - a. Tighten the coil mounting bolt to 24-72 in.-lb. (3-8 N•m).
 - b. Make sure each spark plug wire is connected to the correct tower on the ignition coil. See **Figure 69**.

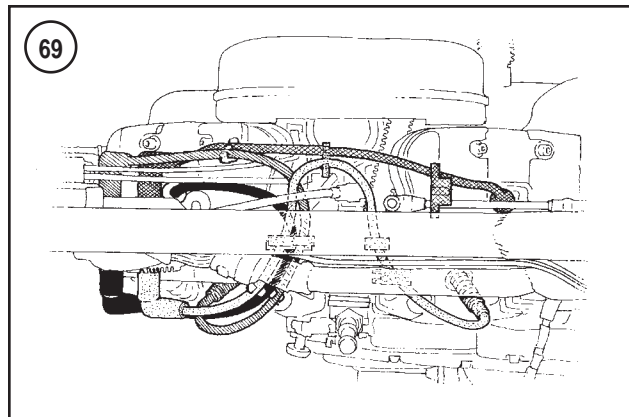
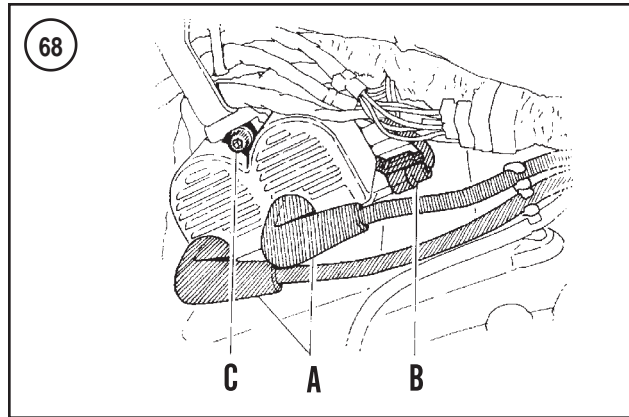

BANK ANGLE SENSOR (1998-2003 MODELS)

Inspection

The bank angle sensor (A, **Figure 70**) is mounted on the side of the battery tray.

1. Support the motorcycle in a vertical position.
2. Start the engine.
3. Set a magnet on top of the bank angle sensor.
4. The engine will stop if the sensor is operating correctly.
5. Reset the sensor by removing the magnet and turning the ignition switch off.

Removal/Installation

1. Remove the left side cover (Chapter Seventeen).
2. Remove the mounting bolt (B, **Figure 70**) and remove the sensor.
3. Disconnect the connector (C, **Figure 70**) from the bank angle sensor.
4. Reverse the removal procedure to install the sensor. Tighten the sensor mounting bolt to 15-20 in.-lb. (1.5-2 N•m).

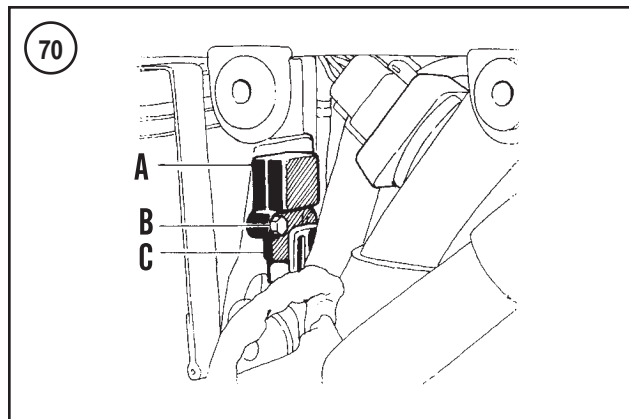

MANIFOLD ABSOLUTE PRESSURE (MAP) SENSOR (1998-2003 1200S MODELS)

Removal/Installation

1. Loosen the rear mounting bolt on the fuel tank and remove the front fuel tank mounting bolt.
2. Pivot the tank up to access the MAP sensor.
3. Remove the vacuum hose from the MAP sensor.
4. Use a screwdriver or other tool and open the tang (A, **Figure 71**). Press the sensor down to release it from the holding bracket.
5. Disconnect the harness connector (B, **Figure 71**) from the MAP sensor and remove the sensor.
6. Install the sensor by reversing the removal procedure. Note the following:
 - a. Press the MAP sensor up into the holding bracket until the tang closes.

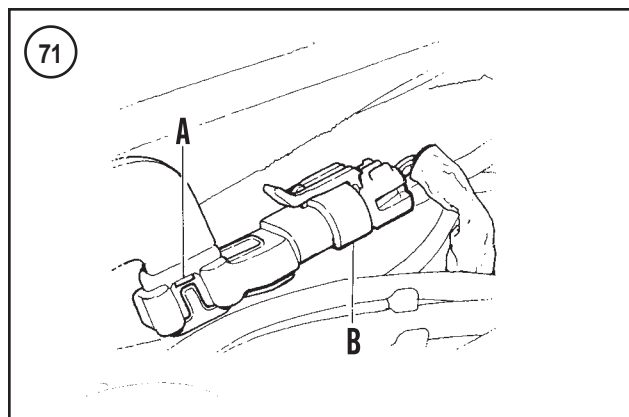



- b. Make sure to reattach the vacuum hose to the sensor.

STARTER

The starting system consists of the starter, starter gears, solenoid and the starter button.

When the starter button is pressed, it engages the starter solenoid switch that completes the circuit allowing electricity to flow from the battery to the starter.

When servicing the starting system, refer to the wiring diagrams located at the end of this manual.

CAUTION

Do not operate the starter for more than five seconds at a time. Let it cool approximately ten seconds before operating it again.

Troubleshooting

Refer to Chapter Two.

Removal

1. Disconnect the negative battery cable as described in this chapter.
2. Remove the primary drive cover (Chapter Six or Chapter Seven).
3. Remove the rear exhaust pipe (Chapter Ten or Chapter Eleven).
4. Disconnect the positive cable and the solenoid electrical connector from the starter (**Figure 72**, typical).
5. Remove the bolts and washers (**Figure 73**) holding the starter to the left crankcase. Remove the starter (**Figure 74**) and gasket from the right side.
6. Service the starter as described in this section.

Installation

1. Install a new gasket onto the starter.
2. Install the starter and gasket into the crankcase.
3. Install the mounting bolts (**Figure 73**) and washers. Tighten the starter mounting bolts to 13-20 ft.-lb. (18-27 N•m).
4. Clean and then reconnect the electrical connectors to the starter motor.
5. Install the primary drive cover (Chapter Six or Chapter Seven).
6. Install the rear exhaust pipe (Chapter Ten or Chapter Eleven).
7. Reconnect the negative battery cable as described in this chapter.

Disassembly

NOTE

*If only servicing to the starter solenoid, refer to the **Starter Solenoid** in this chapter.*

Refer to **Figure 75**.

1. Clean all grease, dirt and carbon from the case and end covers.
2. Disconnect the field coil wire (**Figure 76**).
3. Remove the two starter housing throughbolts (**Figure 77**).
4. Separate the starter field and armature assembly (**Figure 78**) from the solenoid housing.

NOTE

The end cover screws are equipped with O-rings.

75

STARTER

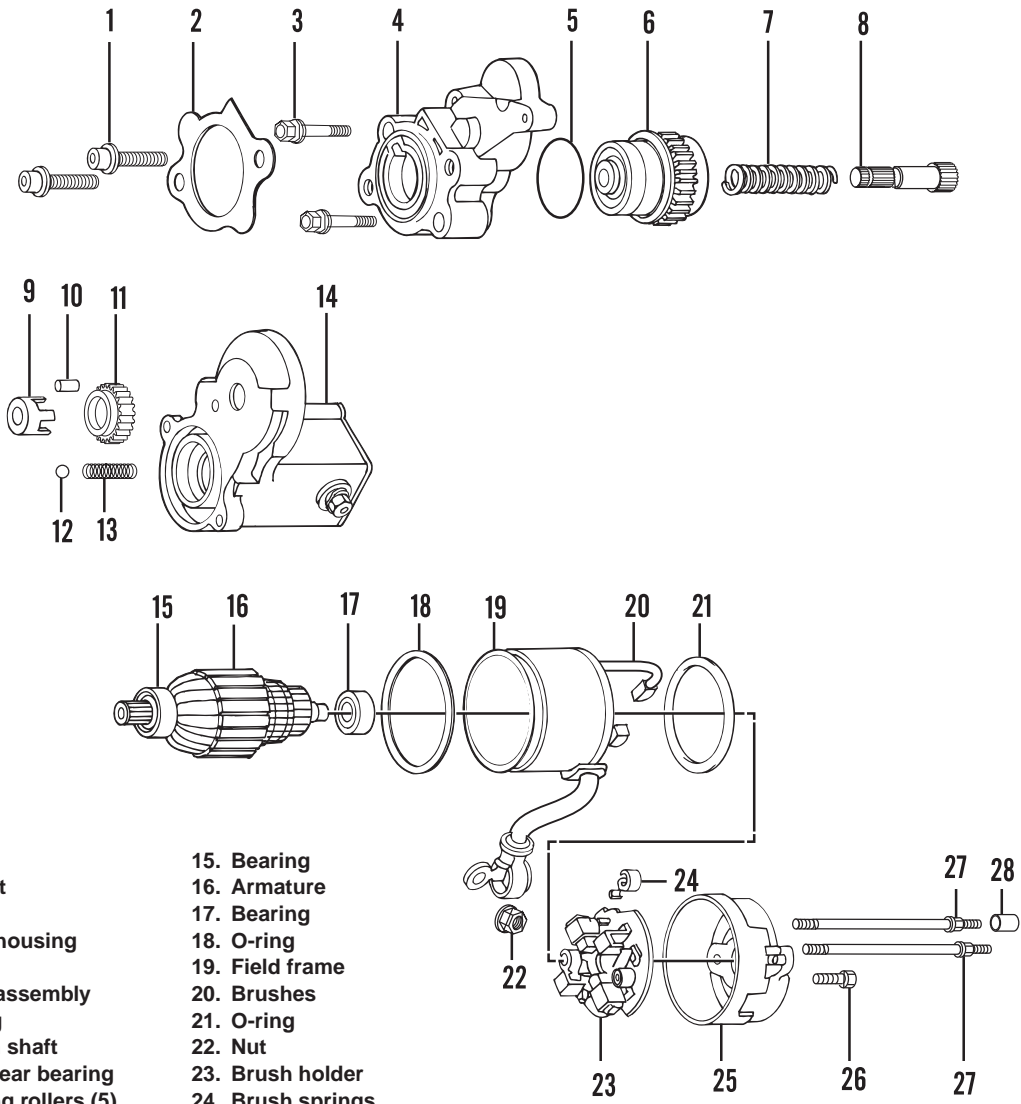

76



77

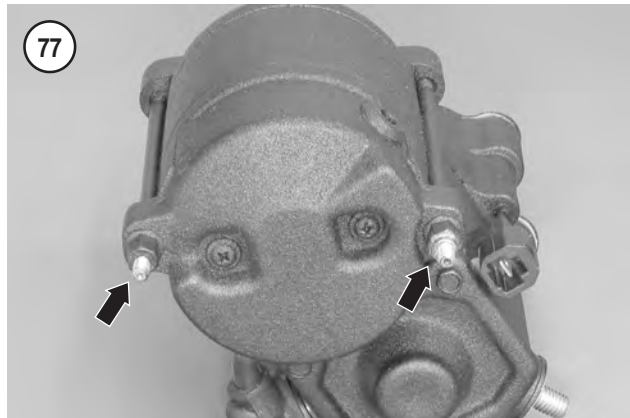

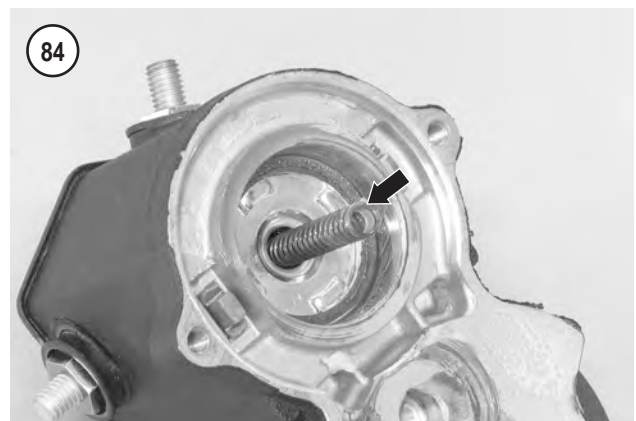
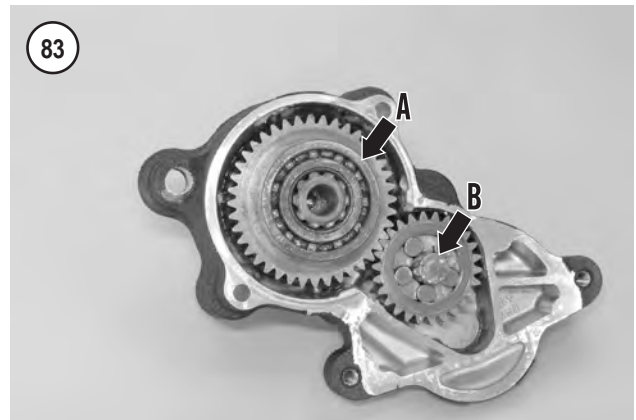
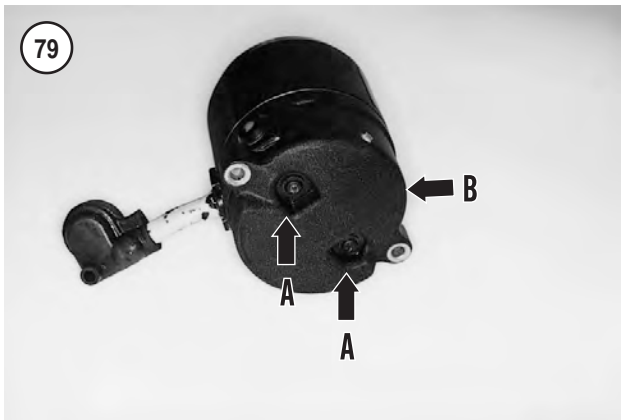

5. Remove the two screws (A, **Figure 79**) securing the end cover to the brush holder. Remove the end cover (B).
6. Lift the field coil brush springs out of their holders with a small hook and remove the brushes from their holders.
7. Slide the brush holder (**Figure 80**) off the commutator.
8. Separate the armature (**Figure 81**) from the field coil assembly.
9. Remove the drive housing mounting screws (**Figure 82**).
10. Tap the drive housing and separate it from the starter (**Figure 83**).
11. Remove the ball and spring (**Figure 84**) from the sole-noid housing.

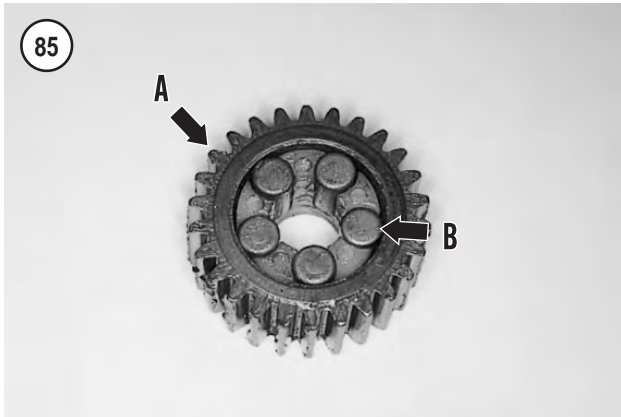

12. Remove the drive assembly (A, **Figure 83**), idler gear (B) and the idler gear bearing assembly (**Figure 85**) from the drive housing.

13. Carefully remove the O-ring (**Figure 86**) out of the groove in the bottom of the drive housing.

14. Inspect the starter assembly as described in this section.

Inspection

1. The starter components should be cleaned thoroughly. Do not clean the field coils or armature in any cleaning solution that could damage the insulation. Wipe these parts off with a clean rag. Do not soak the overrunning clutch in any cleaning solution as the chemicals could dissolve the lubrication within the clutch.

2. Measure the length of each brush (**Figure 87**). If the length is less than the minimum wear length specified in **Table 3**, replace it. Replace the brushes in sets of four, even though only one may be worn to the service limit. See **Figure 88** and **Figure 89**.

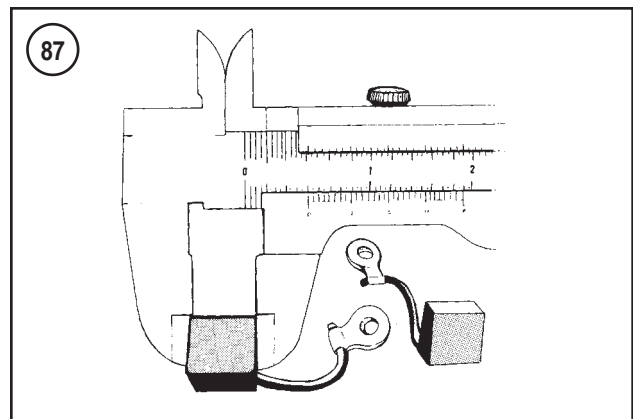

NOTE
The field coil brushes (**Figure 88**) are soldered in position. To replace, first apply heat to the brushes soldered joint to unsolder. Remove the old brushes. Solder the new brushes in place with rosin core solder—do not use acid core solder.

3. Inspect the condition of the commutator (A, **Figure 90**). The mica in the commutator should be at least 0.008 in. (0.20 mm) undercut. If the mica undercut is less than specified, undercut the mica to a depth of 1/32 in. (0.79 mm). When undercutting mica, each groove must form a right angle. Do not cut the mica so that a thin edge is left next to the commutator segment. **Figure 91** shows the proper angle. After undercutting the mica, remove burrs by sanding the commutator lightly with crocus cloth.

4. Inspect the commutator copper bars for discoloration. If a pair of bars is discolored, grounded armature coils are indicated.

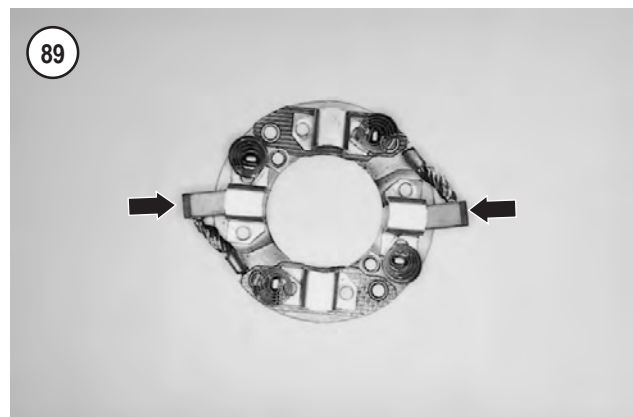

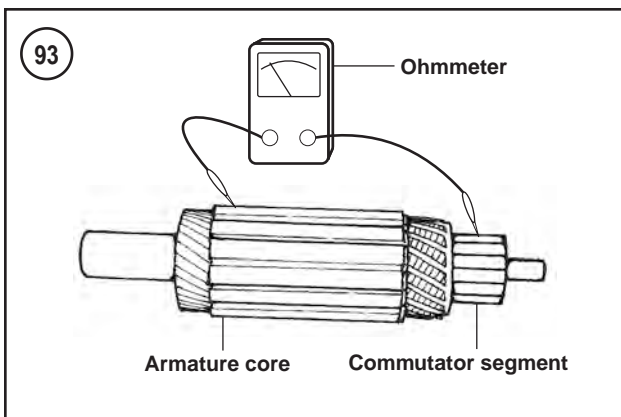
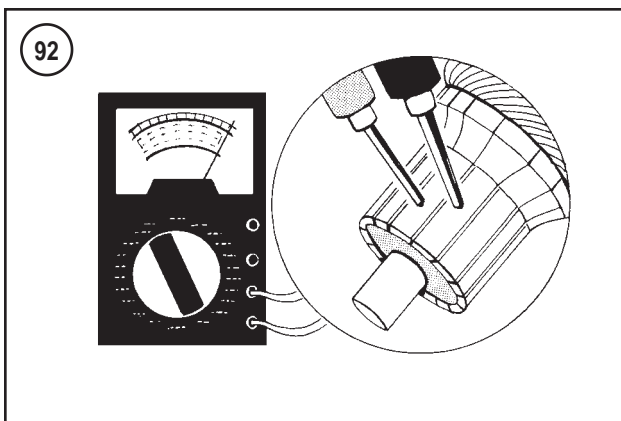
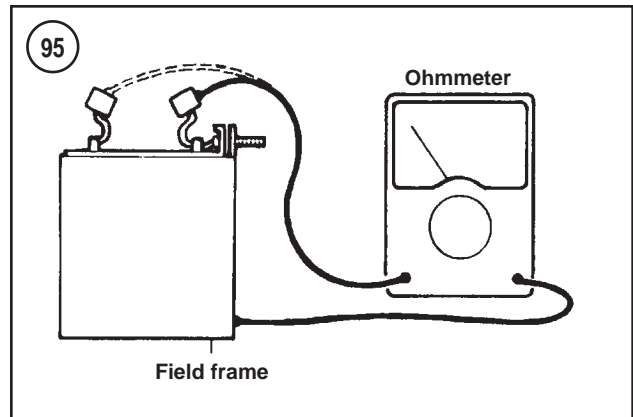
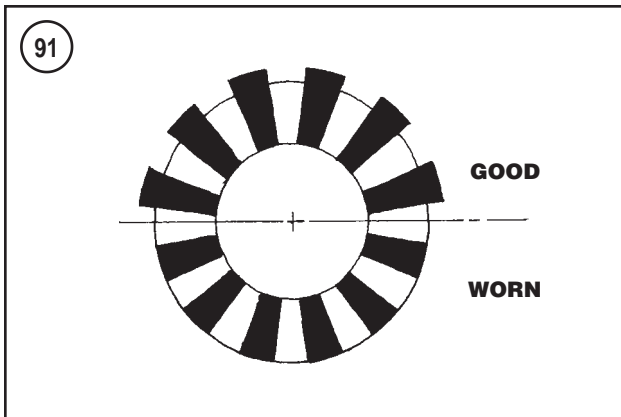
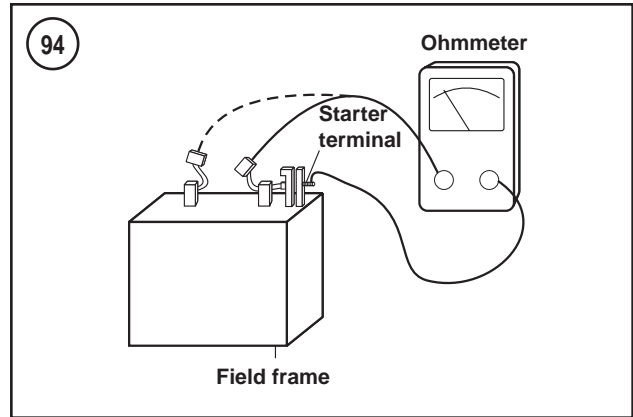
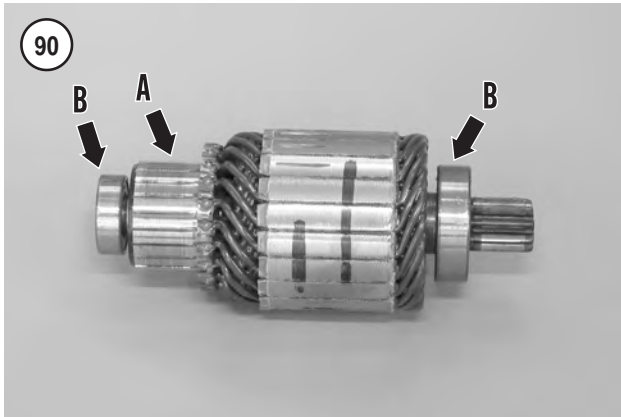

5. The armature can be checked for winding shorts using a growler. Refer this test to a dealership.

6. Place the armature in a lathe or between crankshaft centers and check commutator runout with a dial indicator. If runout exceeds 0.016 in. (0.41 mm), true the commutator in a lathe. When truing the commutator to eliminate the out-of-round condition, make the cuts as light as possible. Replace the armature if the commutator outer diameter meets, or is less, than the wear limit listed in **Table 3**.

7. Use an ohmmeter and check for continuity between the commutator bars (**Figure 92**); there should be continuity between pairs of bars. If there is no continuity between pairs of bars, the armature is open. Replace the armature.

8. Connect an ohmmeter between any commutator bar and the armature core (**Figure 93**); there should be no continuity. If there is continuity, the armature is grounded. Replace the armature.

9. Connect an ohmmeter between the starter cable terminal and each field frame brush (**Figure 94**); there should be continuity. If there is no continuity at either brush, the field windings are open. Replace the field frame assembly.

10. Connect an ohmmeter between the field frame housing and each field frame brush (**Figure 95**); there should be no continuity. If there is continuity at either brush, the field windings are grounded. Replace the field frame assembly.

11. Connect an ohmmeter between the brush holder plate and each insulated brush holder (**Figure 96**); there should

be no continuity. If there is continuity at either brush holder, the brush holder or plate is damaged. Replace the brush holder plate.

12. Service the armature bearings as follows:
 - a. Check the bearings (B, **Figure 90**) on the armature shaft. If worn or damaged, remove and install new bearings with a bearing splitter and a press.

NOTE

Note that the bearings installed on the armature shaft have different part numbers. When replacing the bearings, identify the old bearings before their removal in relationship to their position on the armature. This information can then be used to make sure the new bearings are installed correctly.

- b. Check the bearing bores in the end cover and solenoid housing. Replace the cover or housing if this area is worn or cracked.
13. The drive assembly is bolted onto the end of the solenoid housing. Inspect it as follows:
 - a. Check the teeth on the idler gear (A, **Figure 85**) and drive assembly (A, **Figure 97**) for wear or damage.
 - b. Check for chipped or worn bearing rollers (B, **Figure 85**). Damaged rollers will cause the pinion to turn roughly in the overrunning direction.
 - c. Check the idler gear shaft in the drive housing for wear or damage.
 - d. Replace worn or damaged parts as required.
14. Check the pinion gear (B, **Figure 97**) teeth for cracks, deep scoring or excessive wear.
15. Check the drive assembly bearings (C, **Figure 97**) for wear or damage.

Assembly

Refer to **Figure 75**.

1. Prior to assembly, perform the procedures in *Inspection* in this section to make sure all worn or defective parts have been repaired or replaced. Thoroughly clean all parts before assembly.
2. Apply a thin layer of water-resistant bearing lubricant (Lubriplate 110 or equivalent) onto the drive housing O-ring and insert the O-ring into the groove in the bottom of the housing (**Figure 86**). Make sure the O-ring seats properly in the groove.
3. After the drive assembly components have been cleaned and dried, lubricate all components with water-resistant bearing lubricant (Lubriplate 110 or equivalent).
4. Place the idler gear onto the shaft in the drive housing. Then place the idler bearing cage in the gear so that the open cage end faces toward the solenoid; see B, **Figure 85**. Install the bearing pins in the cage.
5. Insert the drive assembly (A, **Figure 83**) into the drive housing.

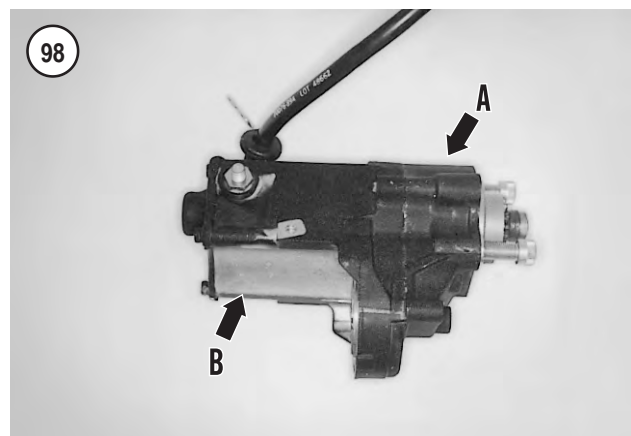
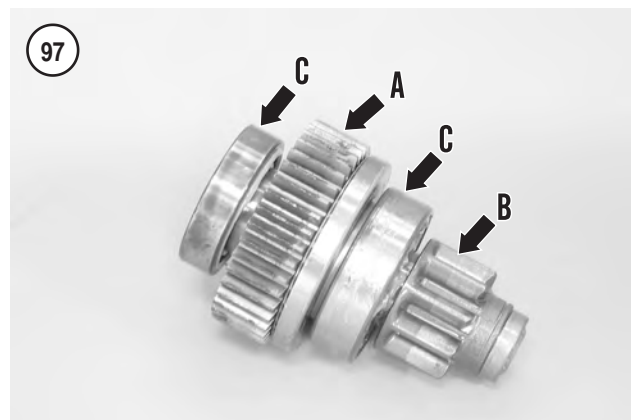
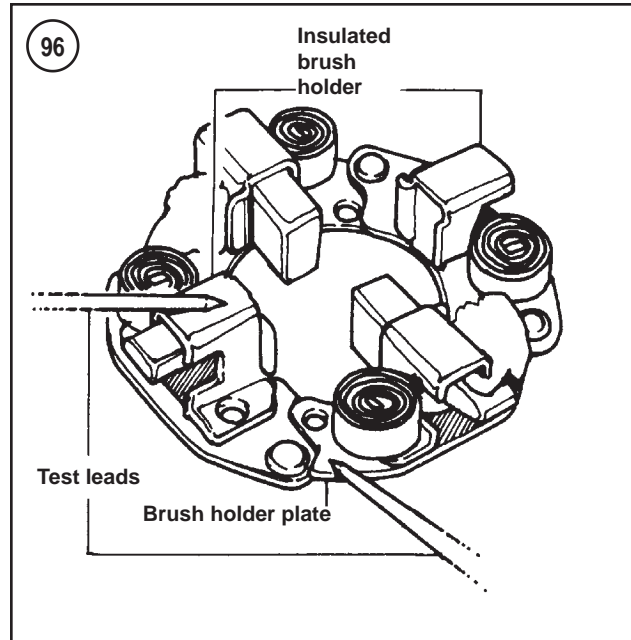

6. Drop the ball into the shaft and slide the spring (**Figure 84**) onto the solenoid plunger shaft.
7. Align the drive housing (A, **Figure 98**) with the solenoid housing (B) and assemble both housings. Secure the drive housing with the screws (**Figure 82**). Tighten the screws securely.

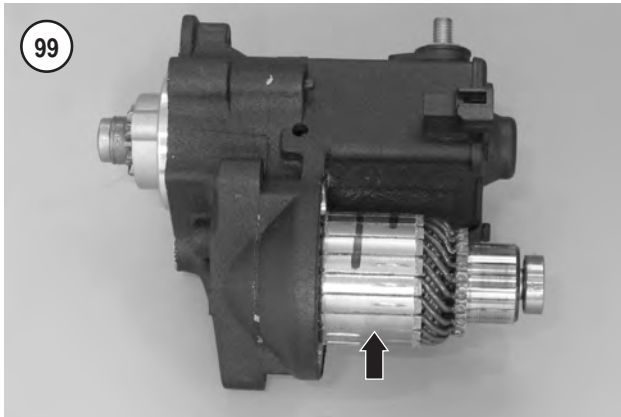

8. Pack the armature bearings with water-resistant bearing lubricant (Lubriplate 110 or equivalent). Then install the armature (**Figure 99**) into the solenoid housing.

NOTE

*The armature is not shown in **Figure 100** for clarity.*



9. Note the slot in the solenoid housing rim (**Figure 100**) and the boss on the field frame (**Figure 101**). Install the field frame around the armature and into the solenoid housing while inserting the boss into the slot.

10. Install the brush plate (**Figure 102**) into the end of the frame and install the four brushes so that they ride on the commutator.

11. Install the two positive brushes as follows:

- a. The positive brushes are soldered to the field coil assembly.
- b. Pull a positive brush out of its brush holder. A piece of wire bent to form a small hook on one end can be used to access the brushes.
- c. Insert the positive brush into its brush holder.
- d. Release the spring so that tension is applied against the brush.
- e. Repeat for the other positive brush.

12. Install the two negative brushes as follows:

- a. The negative brushes are mounted on the brush holder.
- b. Pull a negative brush out of its brush holder. A piece of wire bent to form a small hook on one end can be used to access the brushes.
- c. Insert the negative brush into its brush holder.
- d. Release the spring so that tension is applied against the brush.
- e. Repeat for the other negative brush.



13. Align the slot in the rear cover with the terminal in the frame and install the rear cover (B, **Figure 79**). Install the throughbolts (**Figure 77**) through the starter assembly. Tighten the starter throughbolts to the specification listed in **Table 4**.

14. Secure the brush holder to the rear cover with the two screws (A, **Figure 79**) and washers. Tighten the screws securely.

15. Reconnect the solenoid wire (**Figure 76**).

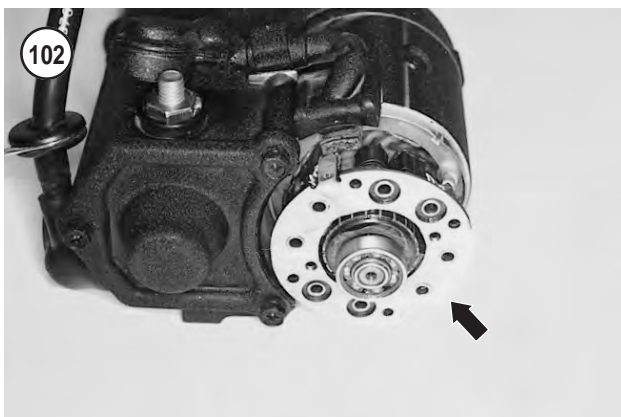

STARTER SOLENOID

Disassembly/Reassembly

Refer to **Figure 103**.

CAUTION

*Do not tighten the inner retaining nut (**Figure 104**) unless the plunger is removed. Otherwise, the internal contact may move and be damaged during operation.*

1. Remove the starter as described in this chapter.

2. Separate the solenoid (B, **Figure 98**) from the starter assembly as described in this chapter.
3. Remove the screws and washers holding the cover to the solenoid housing. Then remove the cover and gasket (**Figure 105**).
4. Remove the solenoid plunger from the solenoid housing (**Figure 106**).
5. Inspect the plunger (**Figure 107**) for wear or damage.
6. Inspect the solenoid housing (A, **Figure 108**) for wear, cracks or other damage. The solenoid housing is only available as part of a complete solenoid unit.
7. Be sure the flat surface of each internal contact (B, **Figure 108**) is parallel to the end of the housing. Loosen the retaining nut and reposition the contact as needed.
8. Installation is the reverse of the preceding steps. Make sure the solenoid plunger shaft engages the spring in the drive assembly shaft.

LIGHTING SYSTEM

The lighting system consists of a headlight, tail-light/brake light combination, turn signals, indicator lights and meter illumination lights.

Always use the correct bulb. The manufacturer lists bulb sizes by part number. The use of a higher wattage bulb will provide a dim light. A lower wattage bulb will burn out prematurely. Replacement bulbs can be purchased through dealerships by part number or by reading the number of the defective bulb and cross-referencing it with another supplier.

Headlight Replacement

1986-1990 models

These models are equipped with a sealed beam halogen headlight. Refer to **Figure 109**.

WARNING

If the headlight has just burned out or has just been turned off, it will be hot. Do not touch the bulb until it cools.

1. Remove the trim ring retaining screw (A, **Figure 110**), then remove the trim ring (B).
2. Remove the headlight bulb from the rubber mount ring.
3. Detach the electrical connector from the bulb, then remove the headlight bulb.
4. Install by reversing the preceding steps while noting the following:
 - a. Make sure the electrical connector is free of corrosion and that the wiring in the headlight housing will not be pinched when the headlight bulb is installed.
 - b. Make sure the electrical connector is pushed on tightly.
 - c. Check headlight operation before riding the motorcycle.

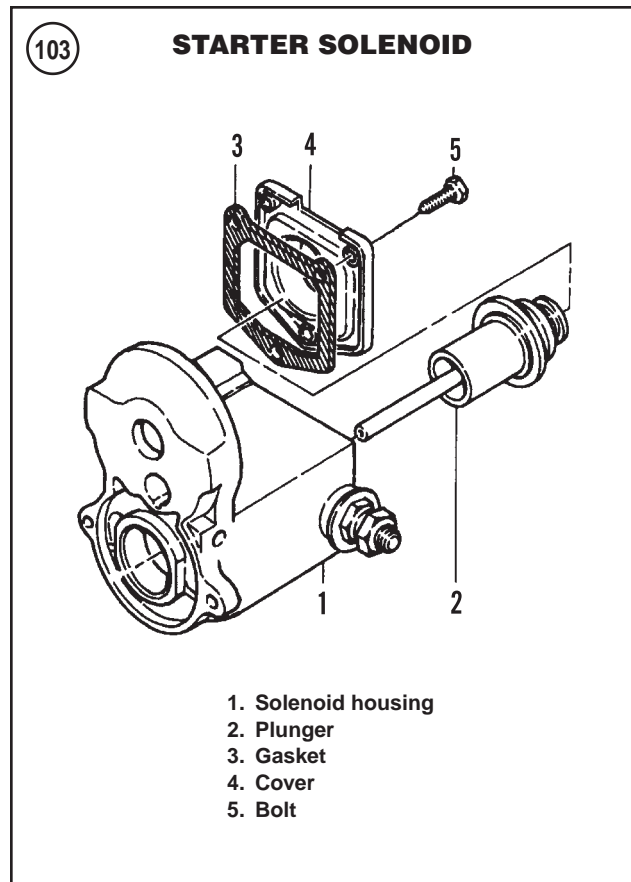

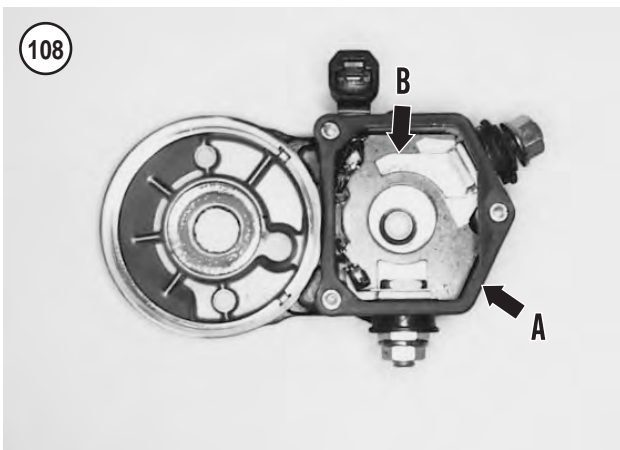
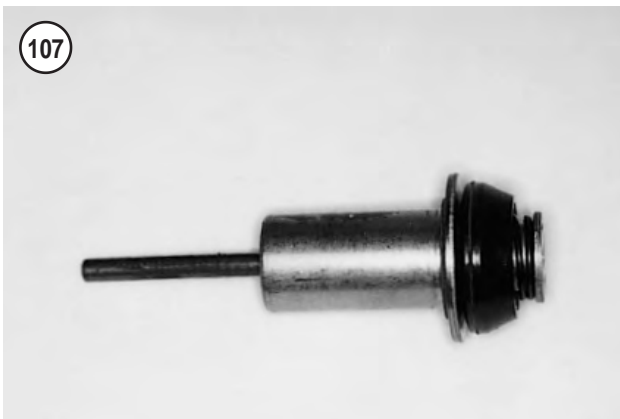
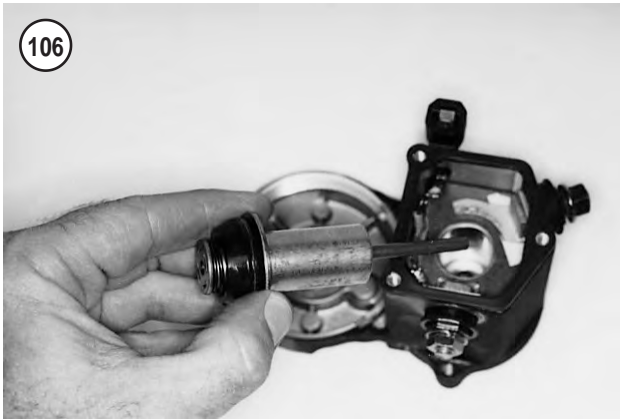

- d. Check headlight adjustment as described in this section.

1991-2003 models

These models are equipped with a quartz halogen bulb. Refer to **Figure 109** and **Figure 111**.

WARNING

If the headlight has just burned out or has just been turned off, it will be hot. Don't touch the bulb until it cools.

NOTE

A single screw secures the trim ring on 883C and 1200C models.

1. Remove the trim ring retaining screws (**Figure 112**), then remove the trim ring.
2. Remove the headlight lens assembly (**Figure 113**) from the housing.
3. Depress the locking tabs on both sides of the electrical connector (**Figure 114**). Then hold the locking tabs down and pull the connector off the headlight terminals. Remove the headlight lens assembly.
4. Remove the socket cover (A, **Figure 115**) from the back of the headlight lens assembly.
5. Depress the ends of the bulb retaining clip (A, **Figure 116**) and unhook the clip from the headlight assembly slots. Pivot the retaining clip away from the bulb.

CAUTION

*When handling a quartz halogen bulb (**Figure 117**), do not touch the bulb glass. Any traces of oil on the bulb will drastically reduce the life of the bulb. Clean any traces of oil from the bulb glass with a cloth moistened in alcohol or lacquer thinner.*

6. Lift the bulb (B, **Figure 116**) out of the headlight lens assembly.
7. Replace the retaining clip (A, **Figure 116**) if damaged.
8. Install by reversing the preceding steps while noting the following:
 - a. On models 883C and 1200C, reinstall the rubber finger gasket (**Figure 118**), if removed, so the small notch properly fits around the bulb holder base.
 - b. Install the bulb and make sure the tabs on the bulb fit into the slots in the lens bulb holder; see B, **Figure 116**.
 - c. Position the socket cover with the TOP mark (B, **Figure 114**). This ensures that the vent holes in the socket cover are positioned at the bottom. Push it on until it is completely seated.
 - d. Make sure the electrical connector is free of corrosion and that the wiring in the headlight housing will not be pinched when the headlight lens is installed.
 - e. Make sure the electrical connector is pushed on tightly.
 - f. Check headlight operation before riding the motorcycle.
 - g. Check headlight adjustment as described in this section.

Headlight Adjustment

Adjust the headlight horizontally and vertically according to the appropriate Department of Motor Vehicle regulations.

Refer to **Figure 119**.

109

HEADLIGHT (ALL MODELS EXCEPT 883C AND 1200C)

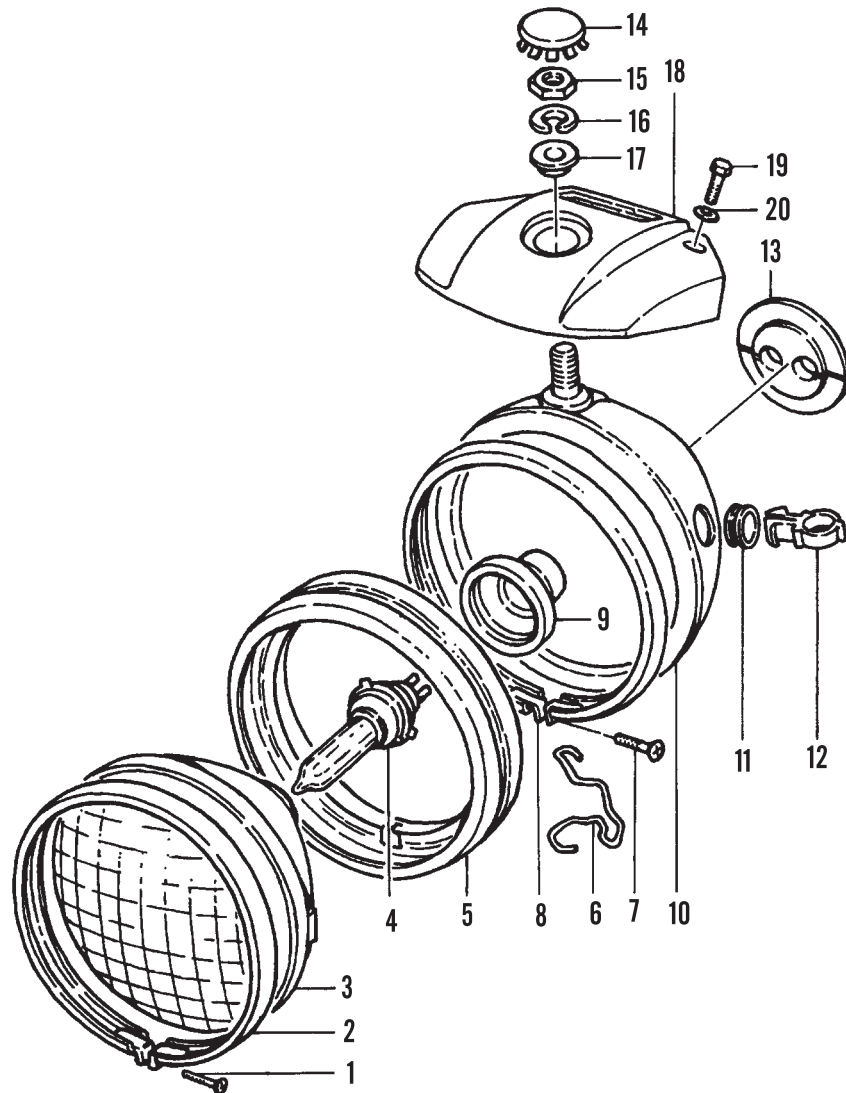

- | | |
|--|-----------------------------------|
| 1. Screw | 11. Grommet |
| 2. Outer molding ring | 12. Cable guide |
| 3. Headlight (1986-1990 models)/ Headlight lens (1991-2003 models) | 13. Grommet (1994-2003 models) |
| 4. Bulb | 14. Plug |
| 5. Rubber mount | 15. Nut |
| 6. Retaining ring | 16. Lockwasher |
| 7. Screw | 17. Grommet |
| 8. Inner molding ring | 18. Headlight bracket |
| 9. Socket cover | 19. Bolt |
| 10. Headlight housing | 20. Washer |

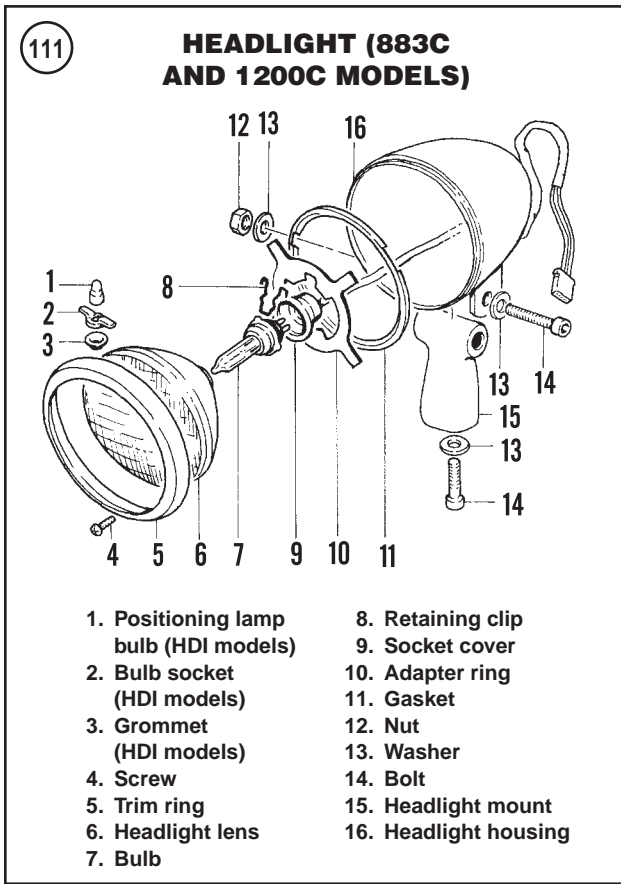

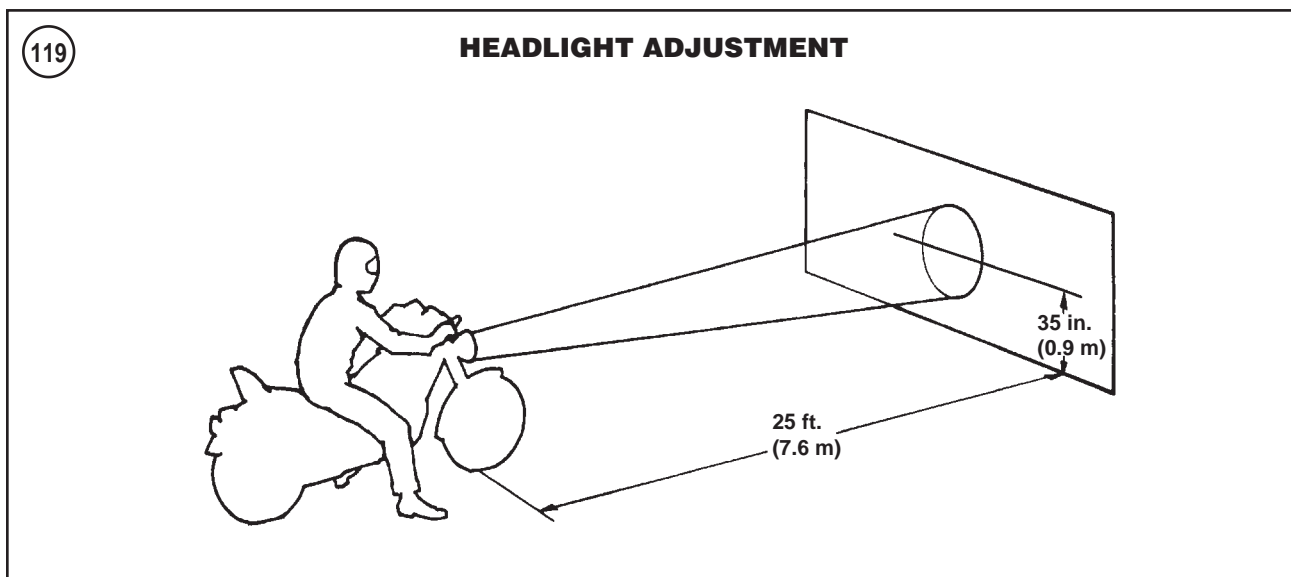
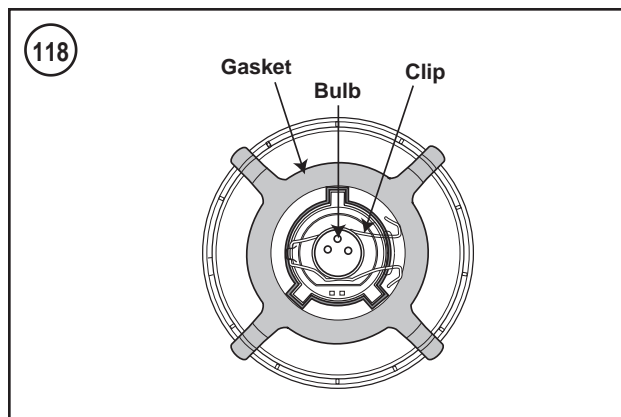

1. Park the motorcycle on a level surface approximately 25 ft. (7.6 m) from the wall.
2. Make sure the tires are inflated to the correct pressure when performing this adjustment. Refer to Chapter Three.
3. Have an assistant of the same approximate weight as the primary rider sit on the seat.
4. Draw a horizontal line on a wall that is 35 in. (889 mm) above the floor.
5. Aim the headlight at the wall and turn on the headlight. Switch the headlight to high beam.
6. Check the headlight beam alignment. The broad, flat pattern of light (main beam of light) should be centered on the horizontal line (equal area of light above and below line).
7. Check the headlight beam lateral alignment. With the headlight beam pointed straight ahead (centered), there should be an equal area of light to the left and right of center.
- 8A. On all models except 883C and 1200C models, if the beam is not aligned as described in Steps 6 and/or 7, adjust it by performing the following.

- a. Remove the plug on top of the headlight bracket (**Figure 120**).
 - b. Loosen the headlight mounting nut (**Figure 121**).
 - c. Tilt or rotate the headlight assembly to adjust the beam position.
 - d. Tighten the headlight mounting nut 120-240 in.-lb. (14-27 N•m).
 - e. Install the plug (**Figure 120**).
- 8B. On 883C and 1200C models, if the beam is not aligned as described in Steps 6 and/or 7, adjust it by performing the following.
- a. Loosen the upper headlight mounting nut (12, **Figure 111**).
 - b. Tilt the headlight assembly up or down to adjust the beam vertically.
 - c. When the beam is properly adjusted, tighten the upper headlight mounting bolt securely.
 - d. Loosen the horizontal adjustment bolt (14, **Figure 111**).
 - e. Move the headlight left or right to adjust the beam horizontally.
 - f. When the beam is properly adjusted, tighten the lower headlight mounting bolt securely.

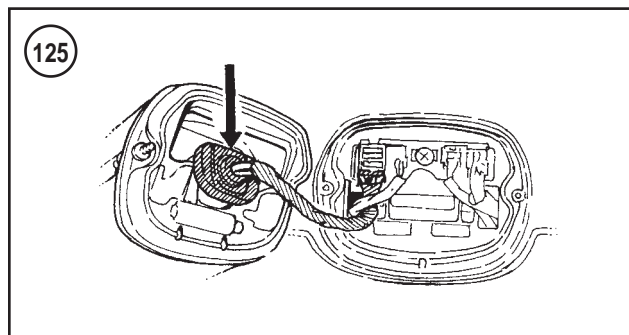
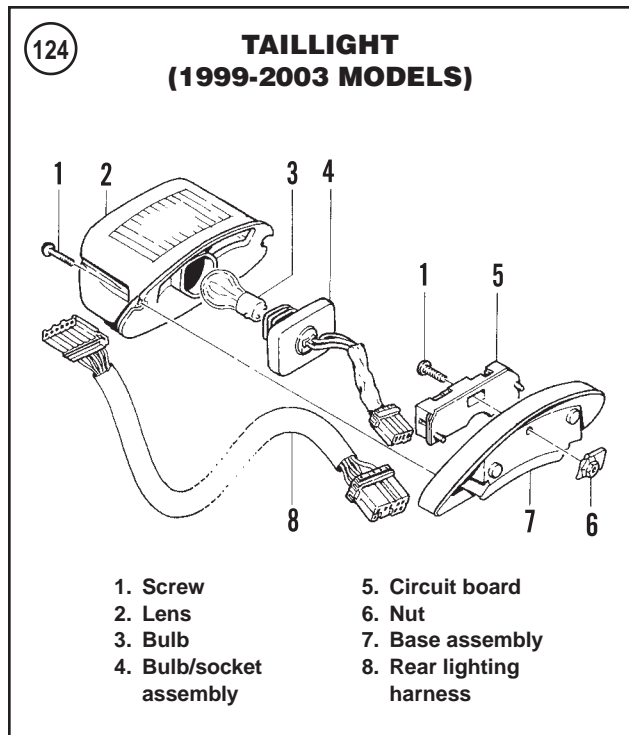

Taillight/Brake Light Replacement

1986-1998 models

WARNING

Make sure the taillight and brake light operate correctly before operating the motorcycle.

1. Remove the two mounting screws and remove the lens assembly (**Figure 122**) from the taillight base.
2. Push in the bulb (**Figure 123**), turn the bulb one-quarter turn counterclockwise and remove the bulb from the socket.
3. Replace the lens gasket if torn or damaged.
4. Install the bulb and lens.

1999-2003 models

Refer to **Figure 124**.

1. Remove the two mounting screws and remove the lens assembly from the taillight base.
2. Pull the bulb socket (**Figure 125**) from the lens.

3. Remove the bulb from the socket.
4. Apply a coat of dielectric grease to the new bulb and insert the bulb into the socket.
5. Install the bulb socket into the lens assembly.
6. Install the lens.

Taillight Base Replacement (1999-2003 Models)

WARNING

Make sure the taillight and brake light operate correctly before operating the motorcycle.

Refer to **Figure 126**.

1. Remove the two mounting screws and remove the lens assembly from the taillight base.
2. Depress the locking tab, and remove the 4-terminal taillight connector (1, **Figure 126**) from the circuit board in the base.
3. Use a terminal pick (part No. HD-39621-28 or equivalent) to depress the locking tab on the top of each remaining connector and remove the left- and right- turn signal connectors and the power connector from the circuit board in the base.
4. Remove the pin housing/circuit board mounting screw from the base.
5. Lift the pin housing (A, **Figure 127**) from the circuit board (B), and then remove the circuit board from the base.
6. Remove the two nuts and bolts, and then remove the base from the fender.
7. Installation is the reverse of removal. Note the following:
 - a. Tighten the base mounting screws to 45-48 in.-lb. (5-5.5 N•m).
 - b. Make sure the circuit board snaps into place in the base.

Turn Signal Bulb Replacement

WARNING

Make sure the turn signals operate correctly before operating the motorcycle.

1. Remove the turn signal lens (**Figure 128**).
2. Push in the bulb (**Figure 129**), rotate it and remove it.
3. Install a new bulb.
4. Install the lens.

Speedometer/Tachometer Bulb Replacement

1986-1994 models

1. Detach the speedometer or tachometer cable (A, **Figure 130**).
2. Remove the rear cover (B, **Figure 130**).
3. Replace a damaged bulb by pulling the bulb socket out of the speedometer or tachometer housing. Remove the bulb from the socket.

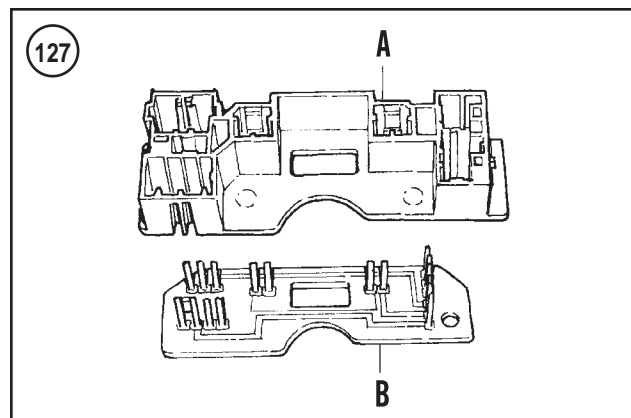
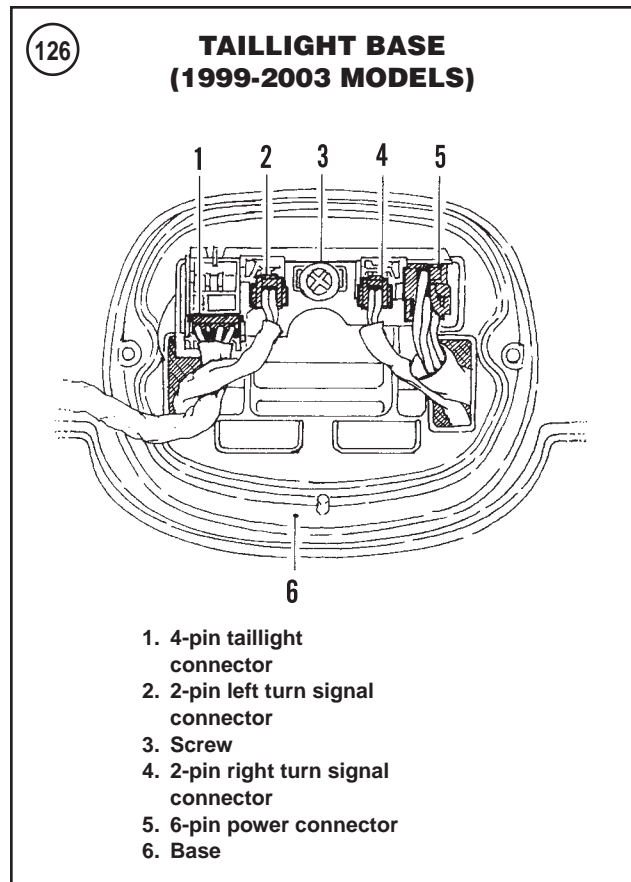

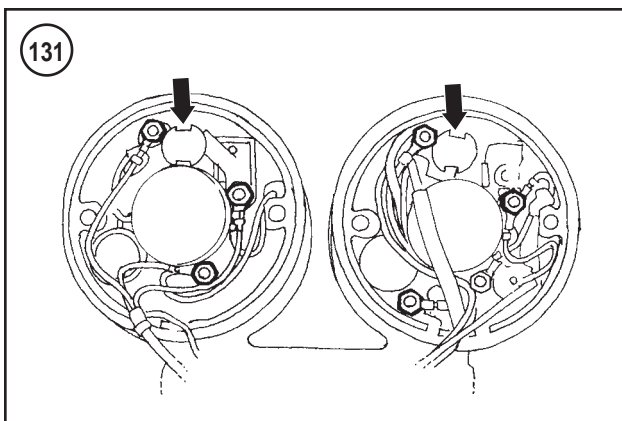
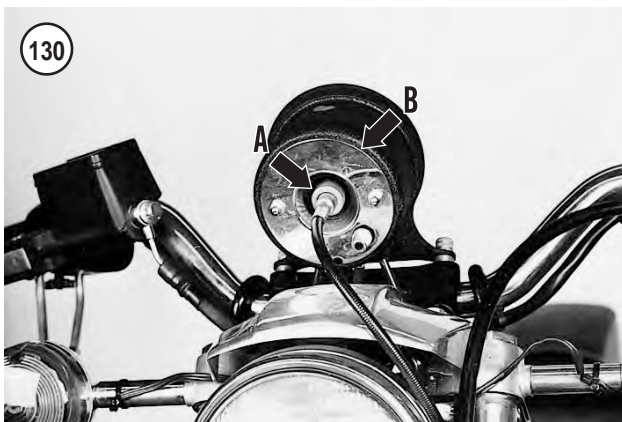

4. Install the new bulb and insert the bulb socket into the instrument housing.
5. Install the rear cover and the speedometer or tachometer cover.

1995-1998 models

1. Remove the rear cover on the speedometer or tachometer.
2. Turn the lamp socket (**Figure 131**) and detach the socket from the speedometer or tachometer.
3. Pull out the lamp from the socket.
4. Insert a new lamp into the socket.
5. Install the lamp socket into the speedometer or tachometer.
6. Install the speedometer or tachometer rear cover.

1999-2003 models

The illumination bulbs for a 1999-2003 model speedometer or tachometer are LED type lamps. The lamps are not available individually but only as part of the instrument panel.

Indicator Light Replacement

1986-1990 models

A panel of indicator lights adjacent to the speedometer provides information concerning the turn signals, high beam, neutral position and oil pressure.

1. Disconnect the cable (A, **Figure 130**) from the instrument(s).
2. Remove the instrument panel screws (**Figure 132**) and lift the instrument(s) away from the handlebar.
3. Replace damaged bulbs by pulling the bulb socket out of the gauge housing. Remove the bulb from the socket.
4. Reverse the preceding steps for installation.

1991-1993 models

Indicator lights on a panel below the speedometer (**Figure 133**) monitor the headlight high beam, oil pressure, neutral position and turn signal lamps. The individual

lamps do not have replaceable bulbs. If one of the lamps becomes faulty, the individual indicator lamp harness (**Figure 134**) must be replaced as an assembly.

1. On 1991 models, remove the speedometer or tachometer if equipped.
2. Remove the headlight lens assembly as described in the *Headlight Replacement* in this section.
3. Remove the headlight adjust nut (**Figure 121**), lockwasher and washer securing the headlight housing to the headlight bracket. Then slide the headlight housing out of the headlight bracket. See **Figure 109**.
4. Disconnect the indicator lamp connector in the headlight housing. **Figure 135** shows the individual lamp positions.
5. Remove the indicator lamp leads from the connector using a terminal tool (part No. HD-97364-71 [**Figure 136**] or equivalent).

NOTE

When replacing the left- or right turn indicator or high beam indicator lamp harness, disconnect its ground wire from the upper fork bracket.

6. Using a sharp, pointed tool, pry the trim cover (**Figure 135**) from the indicator lamp housing on the instrument bracket.
7. Working at the indicator lamp on the instrument bracket, push the indicator light harness through the indicator lamp housing and remove it. See **Figure 137**.
8. Install a new indicator light harness by reversing the preceding steps. Check and adjust the headlight beam as described in this section.

1994 models

Indicator lights on a panel below the speedometer (**Figure 133**) monitor the headlight high beam, oil pressure, neutral position and turn signal lamps. The individual lamps do not have replaceable bulbs. If one of the lamps becomes faulty, the lamp assembly must be removed from the indicator light panel.

NOTE

*Prior to replacing one or more of the indicator light panel lamp assemblies, review the information listed in **Electrical Connectors** in this section.*

1. Remove the headlight bracket bolts (A, **Figure 138**) and lockwashers and remove the headlight bracket (B).
2. Disconnect the black 12-pin Deutsch connector located between the headlight lens assembly and the headlight bracket. See **Figure 139** (speedometer only) or **Figure 140** (speedometer and tachometer) for a schematic diagram of the 12-pin connector. Also, refer to the wiring diagrams at the end of this manual.

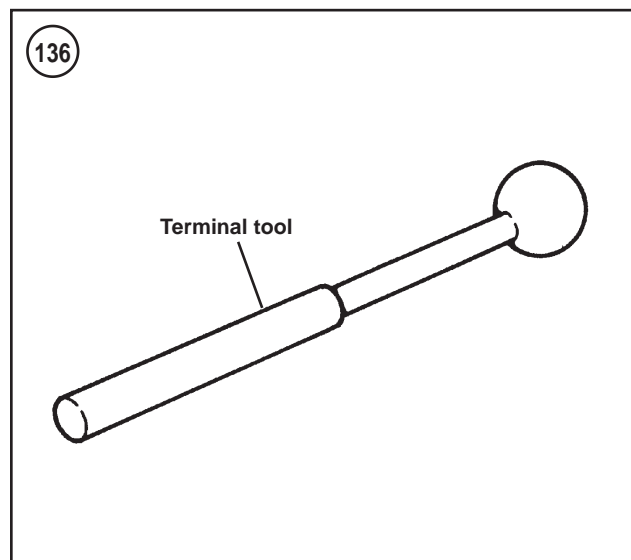
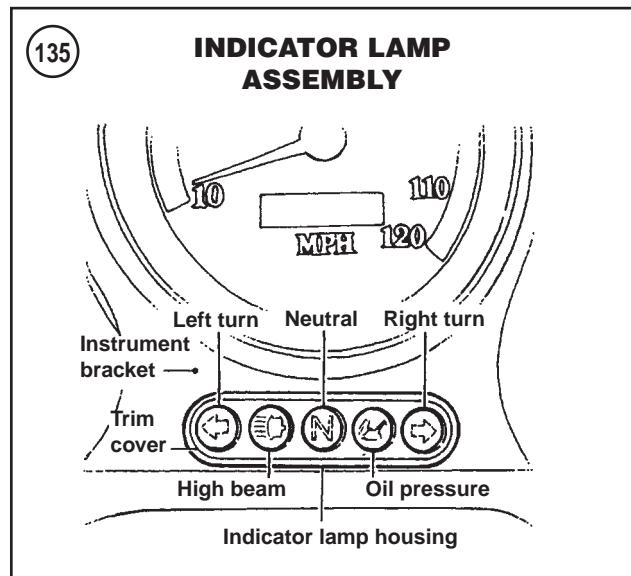
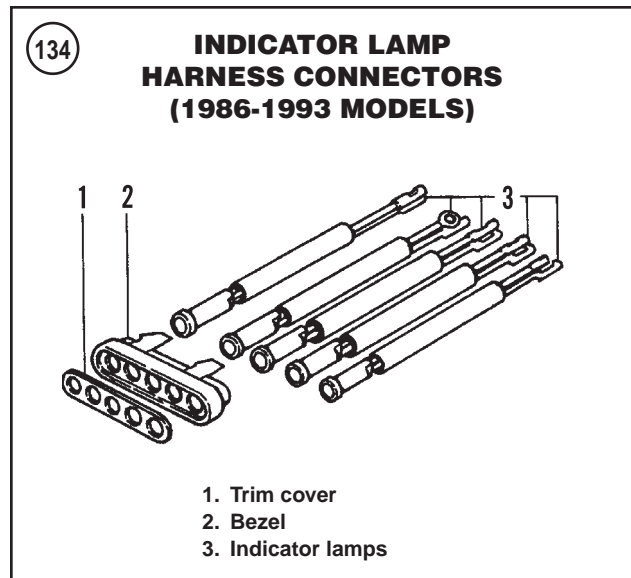

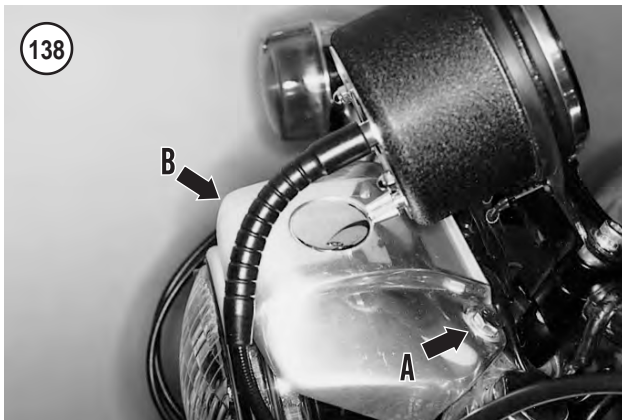

3. Depress the two latches on the connector and disconnect the pin and socket halves.
4. Insert a wide-blade screwdriver between the socket housing and locking wedge at the point shown in **Figure 141**. Then turn the screwdriver 90° and pop the secondary locking wedge off the socket housing.
5. Depress the terminal latches mounted inside the socket housing and pull all of the sockets out through the rear wire seal.
6. Locate the cable strap on the wiring harness leading to the Deutsch connector. Cut the cable strap and remove the conduit.
7. Using a sharp, pointed tool, pry the trim cover (**Figure 135**) from the indicator lamp housing on the instrument bracket.
8. Using wire cutters, cut the wire from the bulb assembly approximately 1 1/2 in. (38.1 mm) above the wire splices. By cutting the wire at this distance, the splice and other bulb connections are left intact

NOTE

The oil and neutral lamps lead to the three-wire splice. The high beam and turn signal lamps lead to the four-wire splice.

9. Push the bulb assembly through the front of the indicator lamp housing and discard.

10. Trim the wires on the replacement bulb assembly to the same length as that on the discarded assembly.
11. Install a new Deutsch socket terminal to the head of the replacement bulb assembly. Match the lead with the colored tape on the wire.
12. Insert the replacement bulb-socket end first through the front of the indicator lamp housing.
13. Align the trim cover (**Figure 135**) with the indicator lamp housing and snap it in place.
14. Install the butt connector to the remaining black, untaped wire on the replacement bulb assembly. Complete the butt splice as described in the *Electrical Connectors* in this chapter.
15. Slide the conduit over the butt splices and wire crimps and install a new cable strap to secure the conduit to the wiring harness.
16. Align and then install the rear wire seal into the the back of the socket housing.
17. Hold the wire socket approximately 1 in. (25.4 mm) behind the contact barrel and push the socket through the holes in the wire seal and into the correct chamber until it clicks in place; see **Figure 139** or **Figure 140** for the individual wire positions. Lightly tug on the wire to verify that it is locked in place.
18. Install the internal seal onto the socket housing lip. Align and insert the tapered end of the secondary locking wedge into the center groove within the socket housing. Then press the wedge down until it locks in place.
19. Align the socket housing tabs with the pin housing grooves and push the connector halves together until they click in place.
20. Place the Deutsch connector underneath the bracket at the backside of the headlight assembly.
21. Align the headlight bracket holes with the mating holes in the upper steering stem bracket. Install the headlight bracket bolts and lockwashers and tighten to 120-192 in.-lb. (14-22 N•m).

1995-2003 models

A panel of indicator lights adjacent to the speedometer provides information concerning the turn signals, high beam, neutral position and oil pressure.

1. Remove the headlight bracket bolts (A, **Figure 138**) and lockwashers and remove the headlight bracket (B).
2. On 883C and 1200C models, remove the covers on the handlebar riser (Chapter Fourteen).
3. Pull out the wire lead of the indicator light requiring replacement (**Figure 142** or **Figure 143**) from the back of the indicator light panel.
4. Pull out the indicator bulb, then install the new bulb.
5. Reverse the removal steps for installation. Lubricate the socket with alcohol or glass cleaner before inserting it into the indicator panel.

139

**SINGLE INSTRUMENT PLUG SPEEDOMETER (ALL 883 MODELS)
12-PIN BLACK**

- | | |
|-------------------------|-------------------------|
| 1. Orange w/ white tape | 7. Seal pin |
| 2. White/ green | 8. Black w/ yellow tape |
| 3. Black w/ brown tape | 9. Black w/ green tape |
| 4. Black w/ white tape | 10. Orange |
| 5. Black w/ violet tape | 11. Black (16 gauge) |
| 6. Seal pin | 12. Black (18 gauge) |

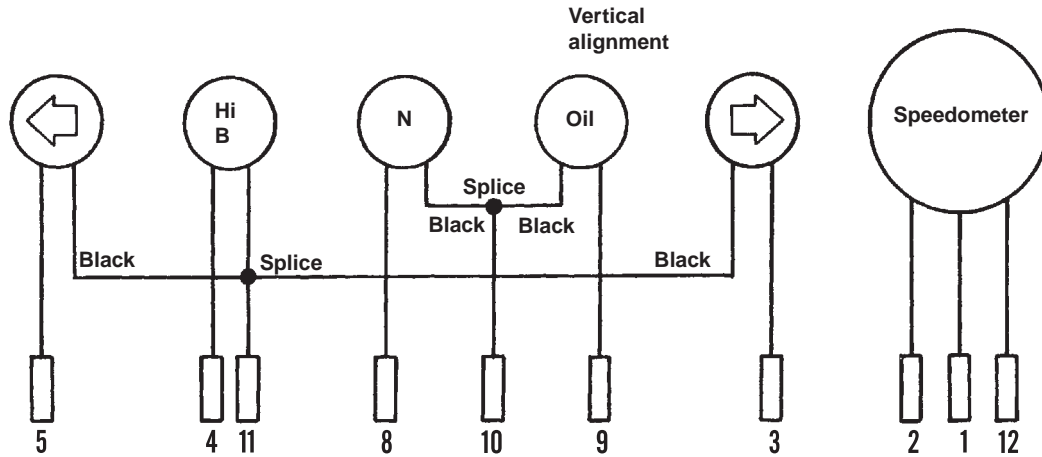
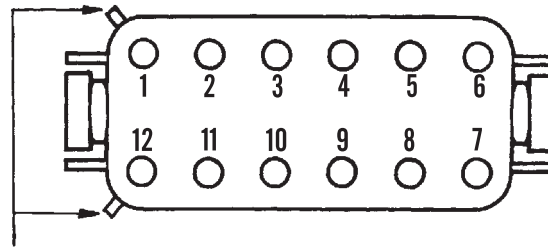

140

**DUAL INSTRUMENT SPEEDOMETER AND TACHOMETER PLUG
(ALL 1200 MODELS) 12-PIN BLACK**

- | | |
|-------------------------|-------------------------|
| 1. Orange w/ white tape | 7. Pink |
| 2. White/ green | 8. Black w/ yellow tape |
| 3. Black w/ brown tape | 9. Black w/ green tape |
| 4. Black w/ white tape | 10. Bright orange |
| 5. Black w/ violet tape | 11. Black (16 gauge) |
| 6. Pale orange | 12. Black (18 gauge) |

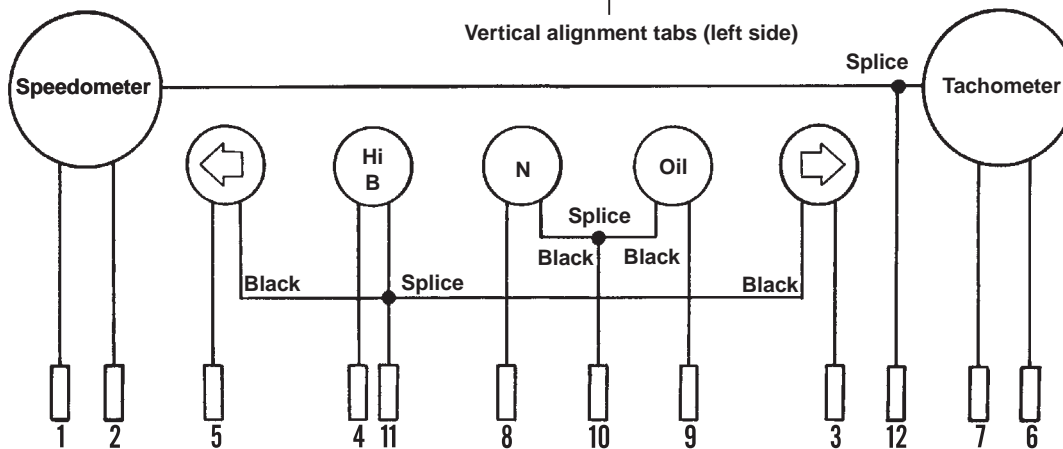
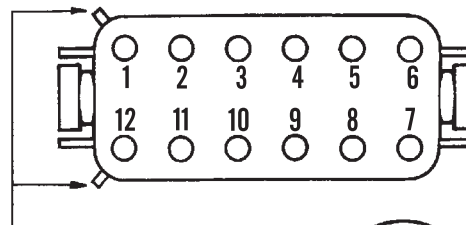

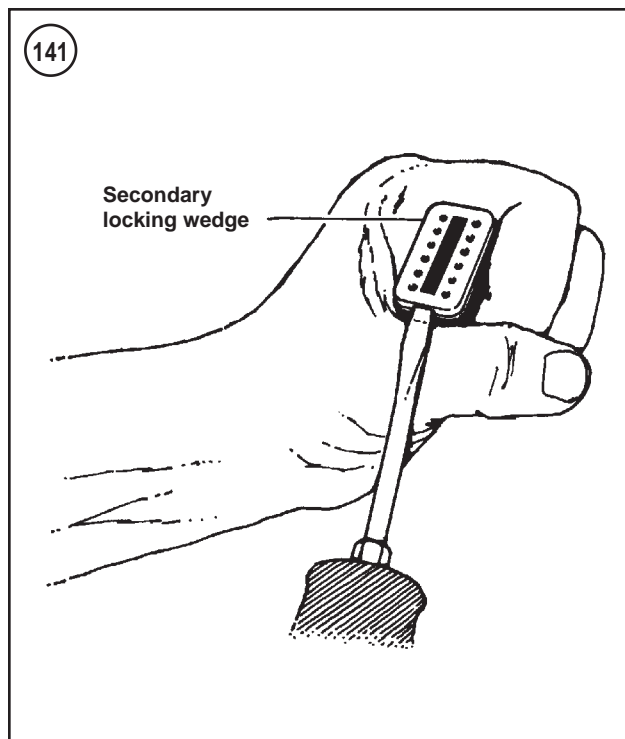

ELECTRONIC SPEEDOMETER/TACHOMETER

All 1995-2003 models are equipped with an electronic speedometer. Some models are also equipped with an electronic tachometer. Refer to **Figure 142** or **Figure 143**.

Troubleshooting

Refer to Chapter Two for troubleshooting procedures.

Removal/Installation

All 1995-1998 models, except 1998 883 models

1. Disconnect the negative battery cable as described in this chapter.
2. To remove the speedometer, perform the following:
 - a. Remove the seat (Chapter Seventeen) and the fuel tank (Chapter Eleven).
 - b. Slide the speedo-sensor connector off the T-stud on the frame, and disconnect the connector (1995-1997 models: **Figure 144**, 1998 models: **Figure 145**).
 - c. Cut the cable ties that secure the speedometer harness to the motorcycle. Note how the cable is routed through the frame; it must be rerouted along the same path during installation.
 - d. Remove the headlight assembly so the speedometer harness can be removed. On 883C and 1200C models, remove the fork bracket and riser covers (Chapter Fourteen).

- e. Remove the odometer boot from the back of the speedometer.
 - f. Remove the cover from the back of the speedometer.
 - g. Remove the nuts from the speedometer studs (A, B and C, **Figure 146**). Remove each wire and the ring connector from the terminal stud. On models where the wires do not have removable connectors, cut each indicated wire approximately one inch from the speedometer, and install ring terminals on the wires to install the speedometer.
3. To remove the tachometer, perform the following:
 - a. Remove the cover from the back of the tachometer.
 - b. Remove the nuts from the tachometer studs, and remove wires (D, E, and F, **Figure 146**) from the tachometer.
 4. Loosen the rear cushion. Push the instrument toward the rear of the motorcycle and out of the housing.
 5. Remove the front cushion from the instrument.
 6. Installation is the reverse of removal while noting the following:
 - a. Route the wiring through the back of the bracket.
 - b. Make sure the front and rear gaskets are properly seated on the bracket.
 - c. When installing a speedometer, install a new reset switch boot, and route the speed-sensor cable along the same path noted during removal.

1998 883 and 1999-2003 models

1. Disconnect the negative battery cable as described in this chapter.
2. When removing the speedometer, perform the following:
 - a. Remove the odometer reset boot from the back of the speedometer.
 - b. Remove the cover from the back of the speedometer and remove the reset switch.
 - c. Depress the lock tab and remove the speedometer connector (A, **Figure 147**) from the back of the speedometer.
3. When removing the tachometer, perform the following:
 - a. Remove the cover from the back of the tachometer.
 - b. Remove the tachometer connector (B, **Figure 147**) from the tachometer.
4. Loosen the rear cushion. Push the instrument toward the rear of the motorcycle and out of the housing.
5. Remove the front cushion from the instrument.
6. Installation is the reverse of removal while noting the following:
 - a. Route the wiring through the back of the bracket.
 - b. Make sure the front and rear gaskets are properly seated on the bracket.
 - c. When installing a speedometer, install a new reset switch boot.

142

SPEEDOMETER
(ALL 1995-2003 MODELS, EXCEPT 883C AND 1200C MODELS)

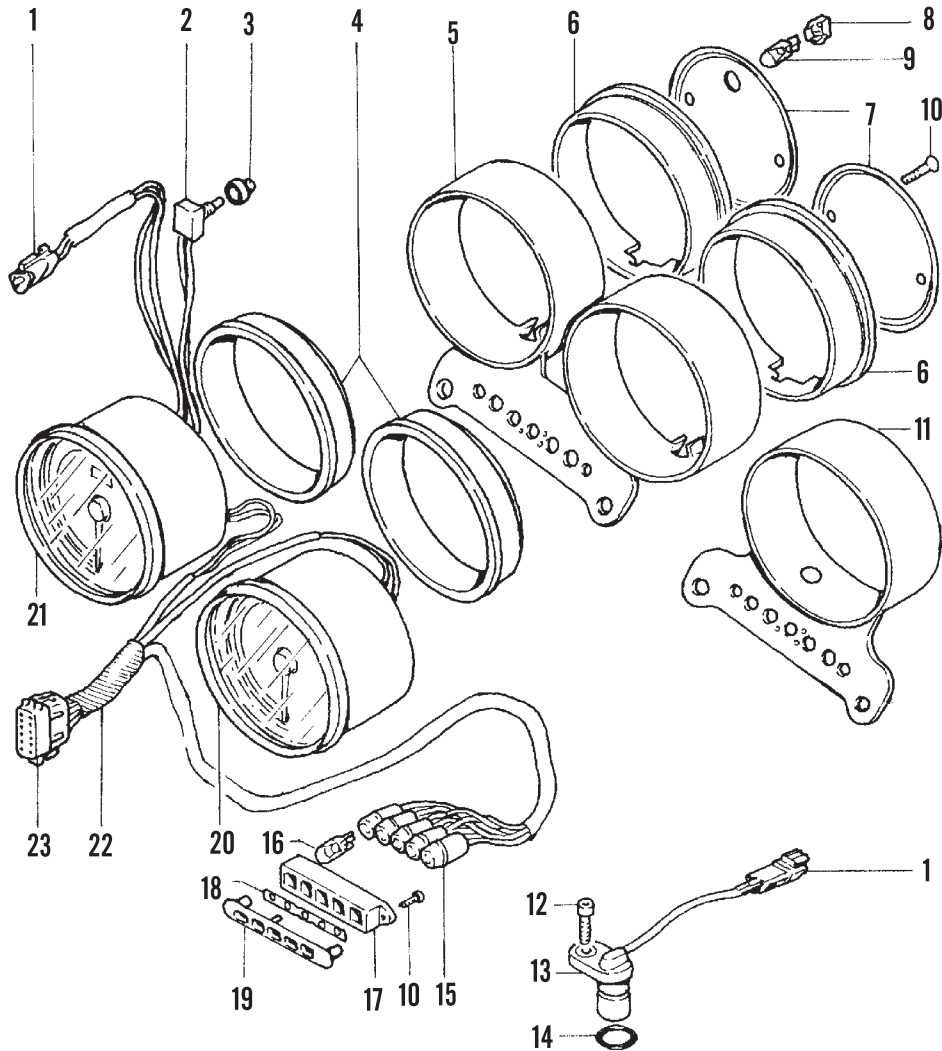

- | | |
|---|----------------------------|
| 1. Speed-sensor connector | 12. Bolt |
| 2. Reset switch | 13. Speed sensor |
| 3. Boot | 14. O-ring |
| 4. Front cushion | 15. Indicator lamp socket |
| 5. Bracket (All 1200 models, except 1200C models) | 16. Indicator lamp bulb |
| 6. Rear cushion | 17. Indicator lamp housing |
| 7. Cover | 18. Indicator lamp lens |
| 8. Socket | 19. Trim plate |
| 9. Bulb (speedometer, odometer, tachometer) | 20. Tachometer |
| 10. Screw | 21. Speedometer |
| 11. Bracket (All 883 models, except 883C models) | 22. Speedometer harness |
| | 23. Main-harness connector |

143

SPEEDOMETER (883C AND 1200C MODELS)

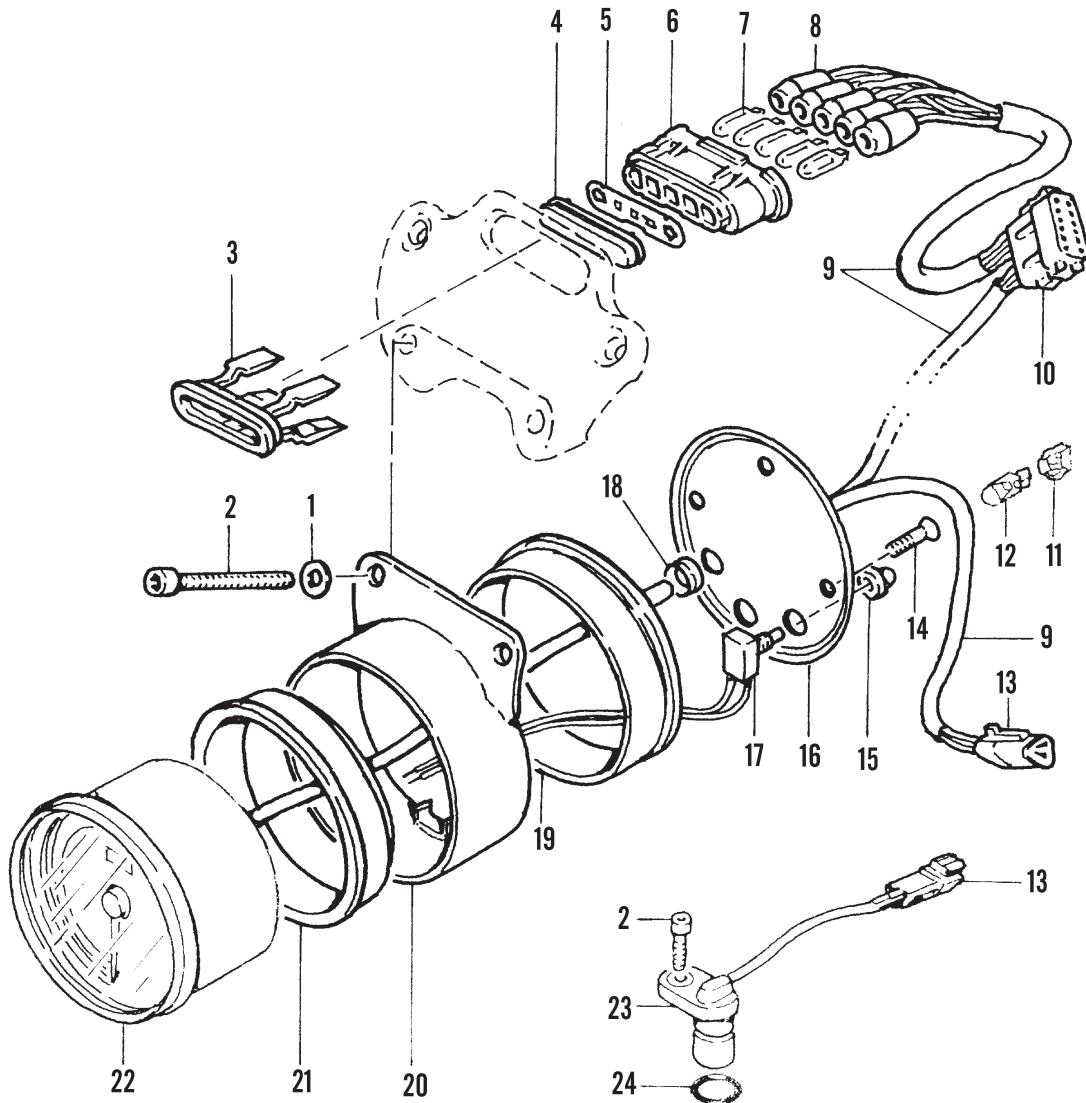

- | | |
|----------------------------|----------------------------|
| 1. Washer | 13. Speed-sensor connector |
| 2. Bolt | 14. Screw |
| 3. Indicator lamp bezel | 15. Boot |
| 4. Indicator lamp lens | 16. Cover |
| 5. Indicator lamp jewel | 17. Reset switch |
| 6. Indicator lamp housing | 18. Grommet |
| 7. Indicator lamp bulb | 19. Rear cushion |
| 8. Indicator lamp socket | 20. Bracket |
| 9. Speedometer harness | 21. Front cushion |
| 10. Main-harness connector | 22. Speedometer |
| 11. Socket | 23. Speed sensor |
| 12. Bulb | 24. O-ring |

Speed-Sensor Removal/Installation

1. Disconnect the negative battery cable as described in this chapter.
2. Remove the seat (Chapter Seventeen).
3. Slide the speed-sensor connector off the T-stud on the frame, and unplug the connector. Refer to **Figure 144** (1995-1997 models) and **Figure 145** (1998-2003 models).
4. The speed-sensor is mounted on the right side of the transmission cases, just below the starter. Remove the sensor mounting screw, lift the sensor from the crankcase, then remove the sensor from the left side of the motorcycle. Note how the sensor cable is routed through the motorcycle. The replacement cable must be rerouted along the same path.
5. Installation is the reverse of removal. Tighten the speed-sensor mounting screw to 80-100 in.-lb. (9-11 N•m).

Reset Switch Removal/Installation

1. Remove the boot from the tripmeter reset knob on the back of the housing.
2. Remove the cover from the back of the speedometer housing.
3. Cut the reset switch wires and splice in a new switch. Follow the procedure in *Sealed Butt Connectors* in this chapter.
4. Installation is the reverse of removal.

SWITCHES

Testing

Test switches for continuity by using an ohmmeter or a self-powered test light at the switch connector plug and operating the switch in each of its operating positions. Compare the results with the switch operating diagrams included in the wiring diagrams located at the end of this manual.

For example, **Figure 148** shows the continuity diagram for a typical ignition switch. It shows which terminals should show continuity when the switch is in a given position. When the ignition switch is in the ignition position, there should be continuity between the red/black, red and red/gray terminals. Note the line on the continuity diagram. An ohmmeter connected between these three terminals should indicate little or no resistance, or a test light should light. When the starter switch is off, there should be no continuity between the same terminals. Replace the switch or button if it does not perform properly.

When testing the switches, note the following:

1. Check the battery as described in this chapter. Charge or replace the battery if necessary.
2. Disconnect the negative battery cable as described in this chapter before checking the continuity of any switch.

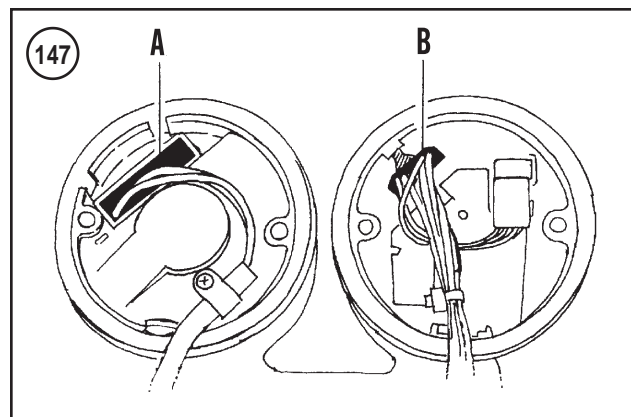
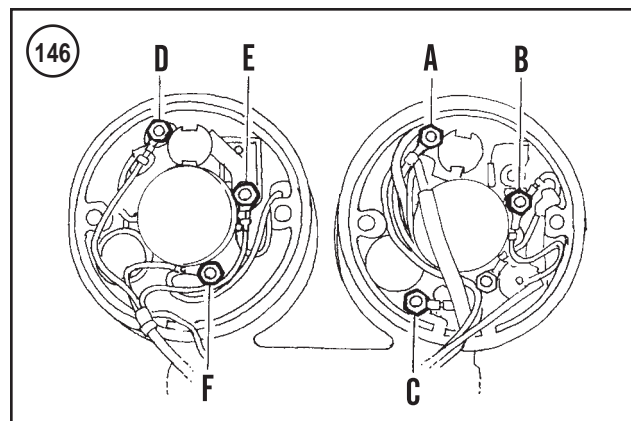
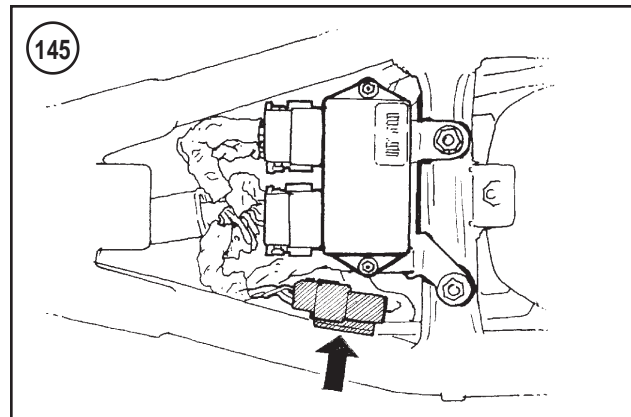
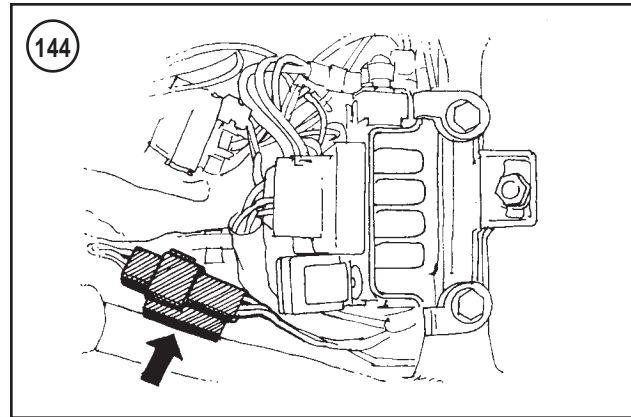

| | | IGNITION SWITCH (TYPICAL) | | |
|-----------|--------|---------------------------|-----|----------|
| | | Red/black | Red | Red/gray |
| Position | Switch | | | |
| Off | | | • | |
| Accessory | | | • | • |
| Ignition | | • | • | • |



3. Detach all connectors located between the switch and the electrical circuit.

CAUTION

Do not attempt to start the engine with the battery disconnected.

4. When separating two connectors, pull on the connector housings and not the wires.

5. After locating a defective circuit, check the connectors to make sure they are clean and properly connected. Check all wires going into a connector housing to make sure each wire is positioned properly and the wire end is not loose.

6. To reconnect connectors properly, push them together until they click or snap into place.



Handlebar Switches (1986-1995 Models)

Left handlebar switch description

The left side handlebar switch housing (Figure 149) is equipped with the following switches:

1. Headlight dimmer.
2. Horn.
3. Left side turn signal.

Right handlebar switch description

The right side handlebar switch housing (Figure 150) is equipped with the following switches:

1. Engine stop/run.
2. Start.
3. Right side turn signal.
4. Front brake light.



Handlebar switch replacement

1. Remove the screws securing the left handlebar switch housing. Separate the switch housing (Figure 151) to access the switches (Figure 152).

2. Remove the screws securing the right handlebar switch housing. Separate the switch housing (Figure 150) to access the switches (Figure 153).

NOTE

The switch assembly may be replaced either by separating the terminal ends from the connector, if the necessary tools are available, or by cutting and splicing the switch wires.

3A. On models without splices, remove the screw and bracket.
 3B. On models with splices, remove the cable strap.
 4. Pull the switch(es) out of the housing.
 5. Cut the switch wire(s) from the switch(es) being replaced.
 6. Slip a piece of heat shrink tubing over each wire cut in Step 5.
 7. Solder the wire end(s) to the new switch. Shrink the tubing over the wire(s).
 8. Install the switch by reversing the removal steps. Note the following:

- a. When clamping the switch housing onto the handlebar, check the wiring harness routing position to make sure it is not pinched between the housing and handlebar.

WARNING

Do not ride the motorcycle until the throttle cables are properly adjusted (Chapter Three).

- b. To install the right side switch housing, refer to *Throttle and Idle Cables* in Chapter Ten or Chapter Eleven.
- c. Tighten the housing screws securely.

**Handlebar Switches
(1996-2003 Models)**

Right handlebar switch description

The right side handlebar switch housing is equipped with the following switches:

1. Engine stop/run.
2. Start.
3. Right side turn signal.
4. Front brake light.

NOTE

*To service the front brake light switch, refer to the **Front brake light switch replacement** in this section.*

Right handlebar switch removal/installation

Refer to Figure 154.

CAUTION

Failure to insert a piece of cardboard between the brake lever and the lever bracket

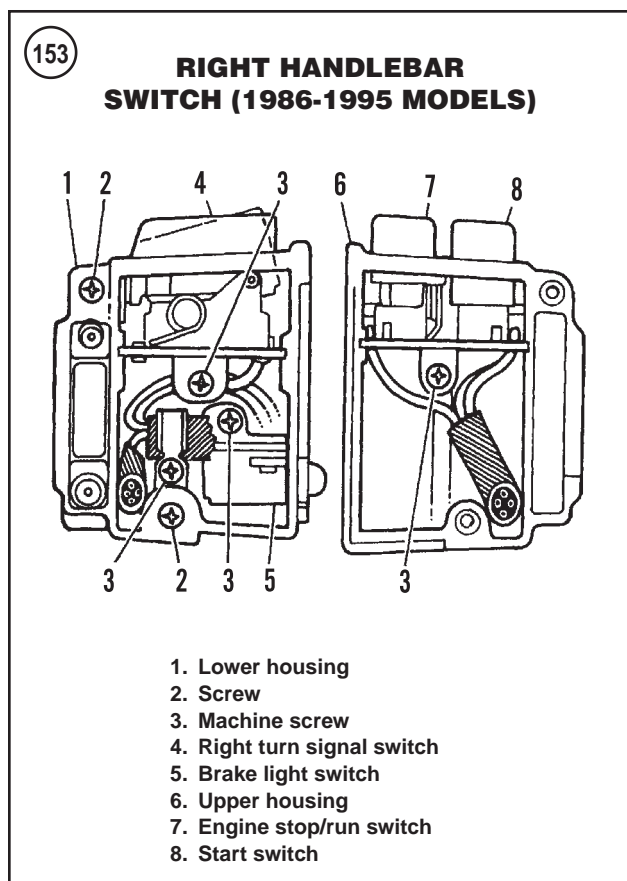
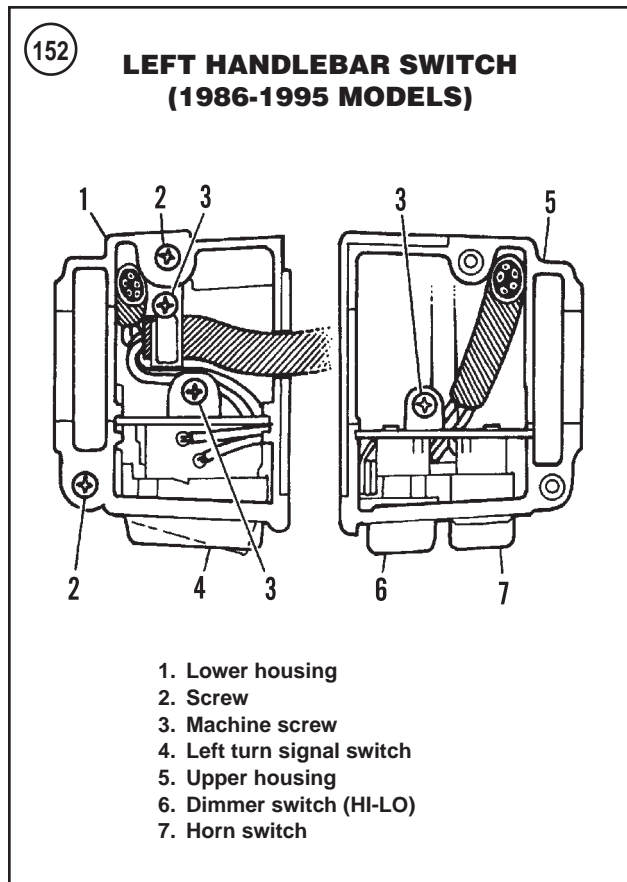

154

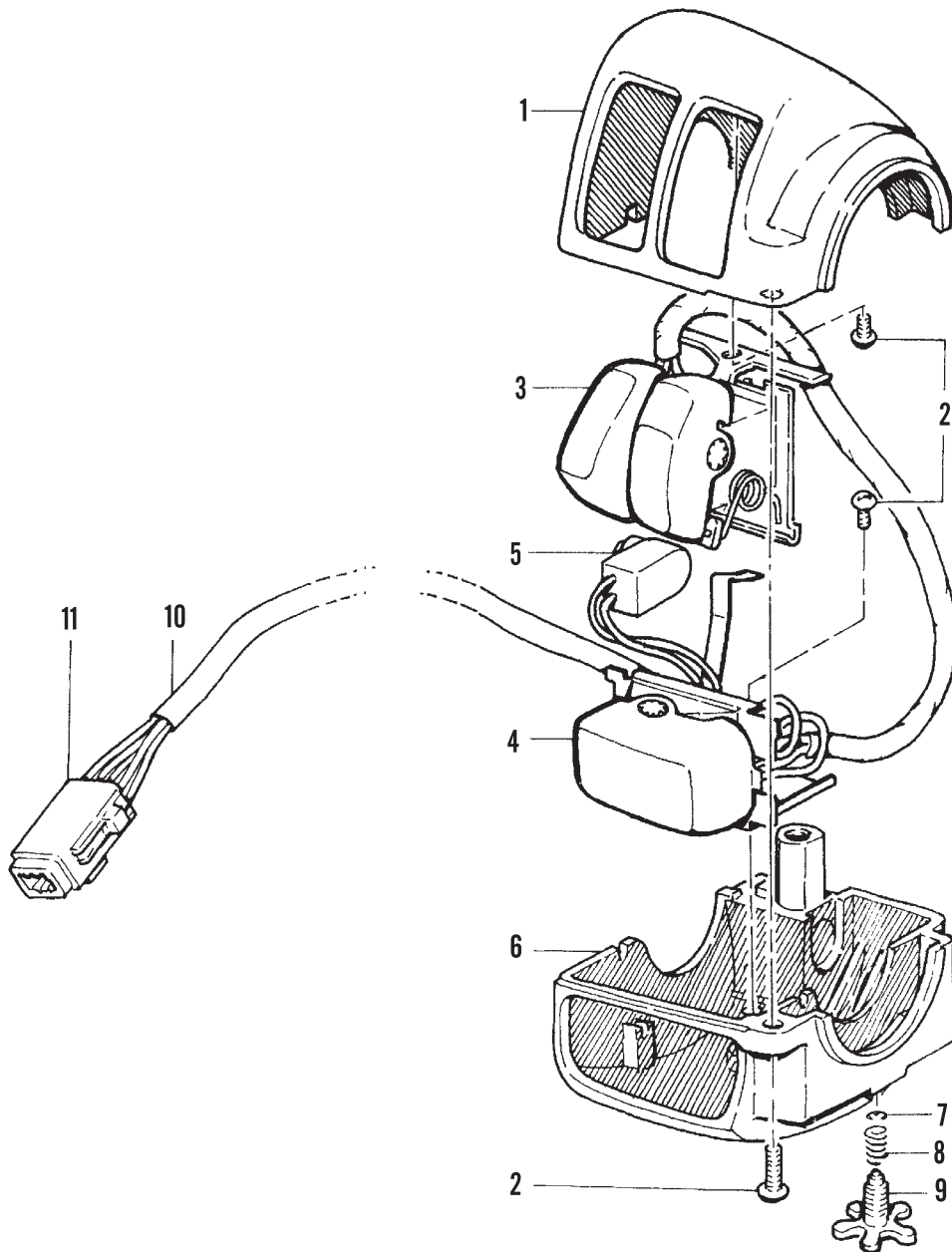
RIGHT HANDLEBAR SWITCH ASSEMBLY (1996-2003 MODELS)

1. Upper housing
2. Screw
3. Start switch/engine stop switch assembly
4. Right turn signal switch
5. Brake switch
6. Lower housing
7. E-clip
8. Spring
9. Friction screw
10. Harness
11. Connector

could result in damage to the boot and plunger on the brake light switch.

1. Insert a piece of 5/32-inch thick cardboard (A, **Figure 155**) between the brake lever and the brake lever bracket
2. Remove the clamp bolts from the master cylinder and remove the master cylinder/brake lever assembly from the handlebar.
3. Remove the screws securing the switch housing to the handlebar. Separate the halves of the switch housing (**Figure 154**). Account for the friction shoe from the end of the friction screw in the lower switch housing.
4. If necessary, remove the throttle and idle control cables from the lower switch housing by performing the following:
 - a. Unhook the cables from the throttle grip and remove the ferrule from the end of each cable.
 - b. Rock the end of the throttle cable back and forth. At the same time, pull the cable insert and the throttle cable from the switch housing. Repeat this procedure to remove the idle control cable from the switch housing.
5. Installation is the reverse of removal. Note the following:
 - a. Make sure the friction shoe and the friction screw are in place in the lower switch housing.
 - b. The switch harness must be properly routed in the grooves in the switch housing.
 - c. Make sure the switch wires are not pinched between the housing halves and loosely install the switch screws.
 - d. Install the master cylinder/brake lever assembly in-board of the switch assembly. Make sure the tab on the lower switch housing engages the slot (B, **Figure 155**) in the top of the brake lever bracket.
 - e. Tighten the master cylinder clamp screws to 70-80 in.-lb. (8-9 N•m).
 - f. Tighten the switch housing screws to 35-45 in.-lb. (4-5 N•m).

Start switch/engine stop switch replacement

NOTE

The start switch (A, **Figure 156**) and the engine stop switch (B) are available only as an assembly.

Refer to **Figure 154**.

1. Remove the right handlebar switch as described in this section.
2. Remove the screw (C, **Figure 156**) securing the switch assembly and remove the start/engine stop switch assembly from the upper switch housing.
3. Pull back the conduit on the harness (D, **Figure 156**), and cut each wire 1/4 inch from the switch.
4. Splice the new switches to the harness.
5. Fit the switch assembly into the upper switch housing. Make sure the end of the switch assembly bracket secures the harness in the switch housing as shown in **Figure 156**.

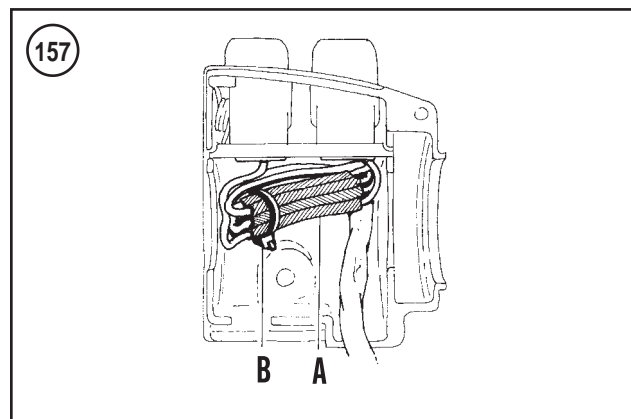
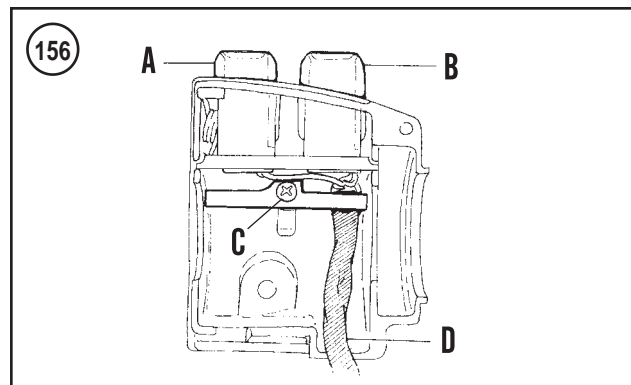
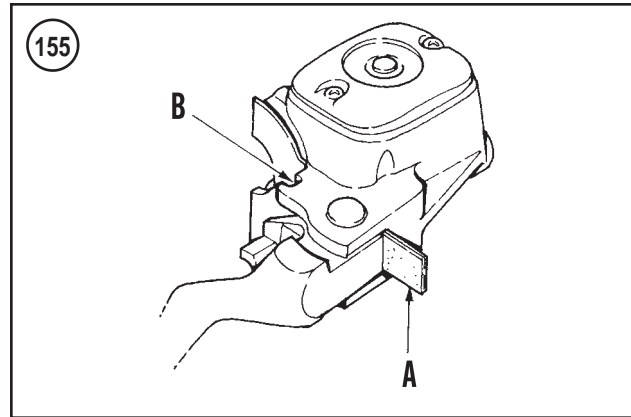

6. Loosely install the switch assembly mounting screw into the upper switch housing. Do not tighten the screw at this time.
7. Gather the splices together, and fit them into the switch housing as shown in A, **Figure 157**.
8. Fit a new 7-inch cable tie (B, **Figure 157**) around the splices. Make sure the cable tie loops around the left end of the switch assembly bracket.
9. Tighten the switch assembly mounting screw (C, **Figure 156**).
10. Tighten the cable tie to draw the splices into the upper switch housing and hold them against the switch assembly bracket. Cut off the excess cable tie. See B, **Figure 157**.

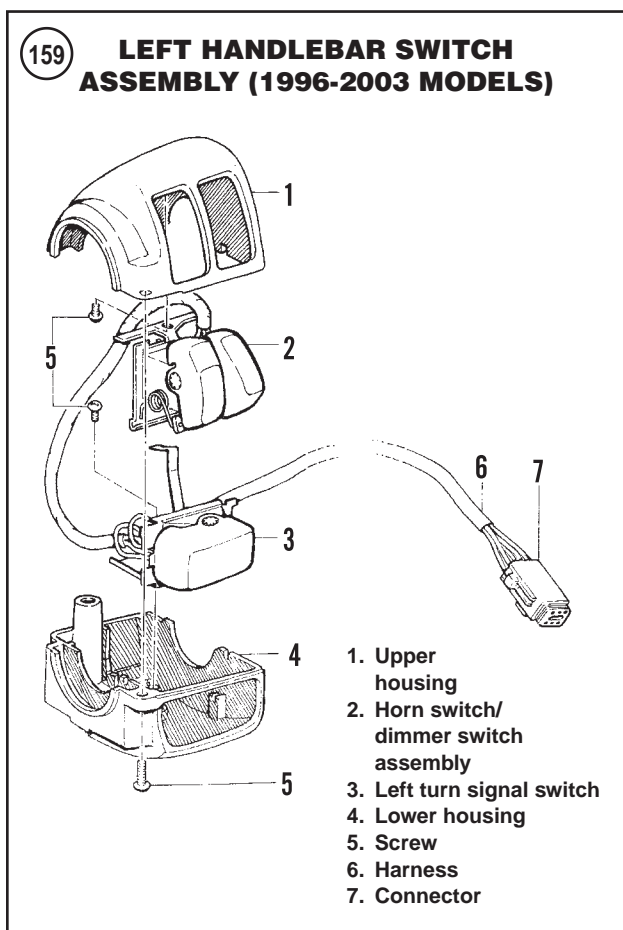
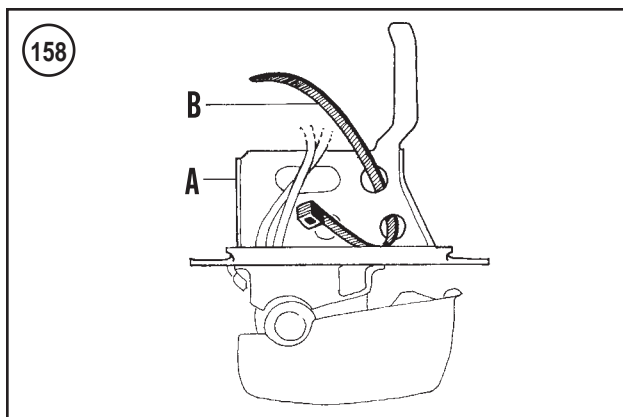

11. Reassemble the right handlebar switch as described in this section.

Right turn signal switch

Refer to **Figure 154**.

1. Remove the right handlebar switch as described in this section.
2. Cut the cable tie that secures the harness to the turn signal switch.

3. Remove the mounting screw and remove the turn signal switch assembly (A, **Figure 158**) from the lower switch housing.
4. Cut the turn signal wires approximately 1-1/2 inches from the end of the switch and discard the switch.
5. Splice the wires of a new turn signal switch to the harness.
6. Fit a 7-inch cable tie through the switch bracket as shown in **Figure 158**.
7. Place the turn signal switch assembly into the lower switch housing and loosely install the mounting screw. Do not tighten the screw at this time.
8. Wrap the cable tie (B, **Figure 158**) around the switch harness and tighten the cable tie so the harness is secured against the turn signal switch bracket. Cut off the excess cable tie.
9. Loop a second cable tie around the switch harness. Gather the splices, wrap them in the cable tie, and tighten the cable tie so the splices are secured against the switch harness. Cut the excess cable tie.
10. Tighten the turn signal switch mounting screw securely.
11. Reassemble the handlebar switch as described in this section.

Left handlebar switch removal/installation

Refer to **Figure 159**.

1. Loosen the clamp bolts securing the clutch-lever assembly to the handlebar, then remove the clutch lever assembly.
2. Remove the screws securing the switch housing to the handlebar. Separate the halves of the switch housing (**Figure 151**).
3. Installation is the reverse of removal. Note the following:
 - a. The switch harness must be properly routed in the grooves in the switch housing.
 - b. Make sure that no wire is pinched between the switch housing halves.
 - c. Install the clutch lever assembly on the inboard side of the switch housing.
 - d. Make sure the tab on the lower switch housing engages the slot in the bottom of the clutch lever bracket.
 - e. Tighten the clutch lever clamp bolts to 60-80 in.-lb. (7-9 N•m).
 - f. Tighten the switch housing securing screws to 35-45 in.-lb. (4-5 N•m).

Horn switch/dimmer switch removal/installation

Refer to **Figure 159**.

NOTE

The horn switch (A, **Figure 160**) and the dimmer switch (B) are available only as an assembly.

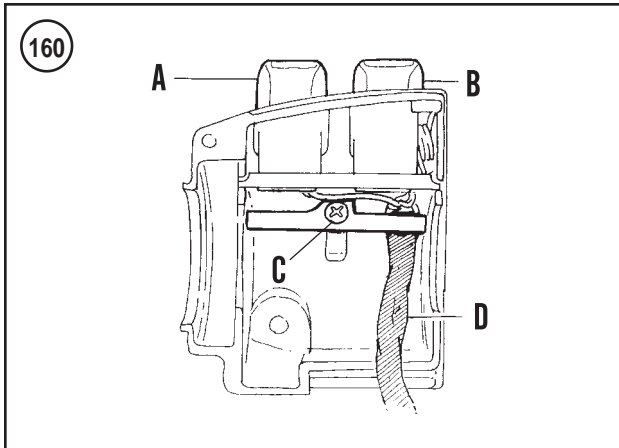

1. Remove the left handlebar switch assembly as described in this section.
2. Remove the screw (C, **Figure 160**) securing the switch assembly and remove the horn/dimmer switch assembly from the upper switch housing.
3. Pull back the conduit on the harness (D, **Figure 160**), and cut each wire 1/4-inch from the switch.
4. Splice the new switches to the harness.
5. Fit the switch assembly into the upper switch housing. Make sure the end of the switch assembly bracket secures the harness in place in the switch housing as shown in **Figure 160**.
6. Loosely install the switch assembly mounting screw into the upper switch housing. Do not tighten the screw at this time.
7. Gather the splices together and fit them into the switch housing as shown in A, **Figure 161**.
8. Fit a new 7-inch cable tie around the splices. Make sure the cable tie loops around the left end of the switch-assembly bracket.
9. Securely tighten the switch assembly mounting screw.
10. Tighten the cable tie to draw the splices into the upper switch housing and hold them against the switch-assembly bracket. Cut off the excess cable tie. See B, **Figure 161**.
11. Reassemble the left handlebar switch as described in this section.

Left turn signal switch

Refer to **Figure 159**.

1. Remove the left handlebar switch as described in this chapter.
2. Cut the cable tie that secures the harness to the turn signal switch.
3. Remove the mounting screw and remove the turn signal switch assembly (A, **Figure 162**) from the lower switch housing.
4. Cut the turn signal wires approximately 1-1/2 inches from the end of the switch and discard the switch.
5. Splice the wires of a new turn signal switch to the harness.

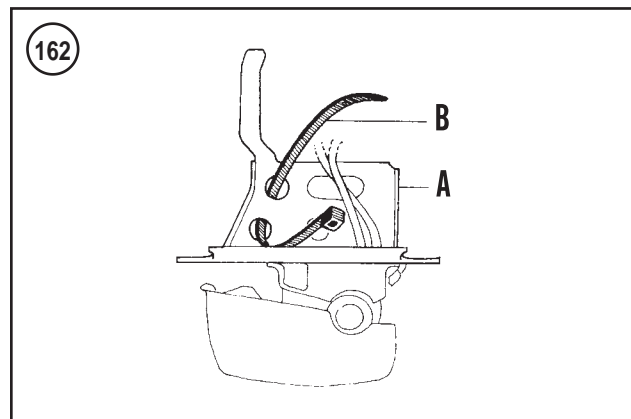
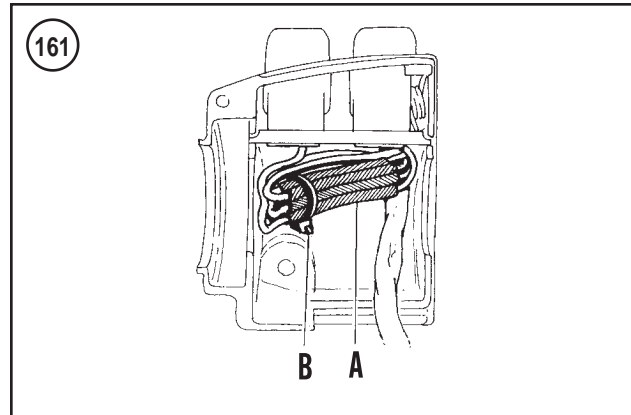

6. Fit a 7-inch cable tie through the switch bracket as shown in **Figure 162**.
7. Place the turn signal switch assembly into the lower switch housing, and loosely install the mounting screw. Do not tighten the screw at this time.
8. Wrap the cable tie (B, **Figure 162**) around the switch harness and tighten the cable tie so the harness is secured against the turn signal switch bracket. Cut the excess cable tie.
9. Loop a second cable tie around the switch harness. Gather the splices, wrap them in the cable tie, and tighten the cable tie so the splices are secured against the switch harness. Cut the excess cable tie.
10. Tighten the turn-signal switch mounting screw securely.
11. Reassemble the handlebar switch as described in this section.

Front Brake Light Switch Replacement (1996-2003 Models)

NOTE

Refer to **Handlebar Switches** in this section when replacing the front brake light switch on 1986-1995 models.

The front brake light switch (**Figure 154**) is mounted in the right handlebar switch lower housing.

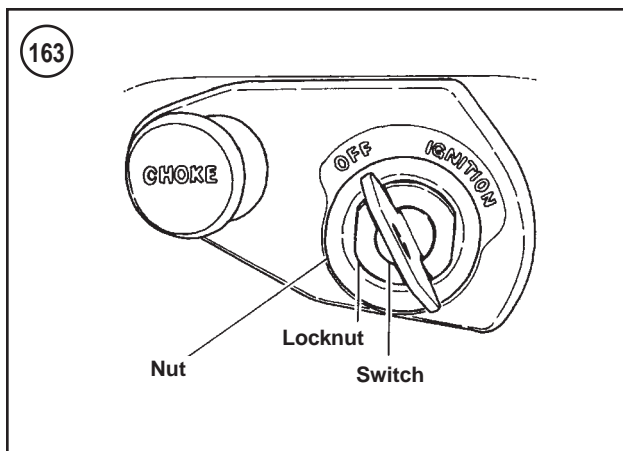

1. Separate the right handlebar switch housing as described in *Handlebar Switch Replacement* in this section.
2. If the wedge between the switch and the switch housing is still in place, remove it.
3. Cut the switch wires 1 in. from the defective switch.
4. While depressing the switch plunger, rotate the switch upward, rocking it slightly, and remove it from the switch housing.
5. Check that the plunger is square in the bore and that the boot is not compressed, collapsed or torn. Work the plunger in and out until the boot is fully extended.

6. Slip a piece of heat shrink tubing over each wire cut in Step 3.

7. Solder the wire ends to the new switch. Then shrink the tubing over the wires.

8. Install the switch by reversing the removal steps. Note the following:

- a. When clamping the switch housing onto the handlebar, check the wiring harness routing position to make sure it is not pinched between the housing and handlebar.

WARNING

Do not ride the motorcycle until the throttle cables are properly adjusted (Chapter Three).

- b. To install the right handlebar switch housing, refer to the *Throttle and Idle Cables* section in Chapter Ten or Chapter Eleven.

Ignition/Lighting Switch

The ignition/light switch is not servicable. If the switch is faulty, it must be replaced.

Removal/installation (1986-1991 models)

1. Disconnect the negative battery cable as described in this chapter.
2. Remove the ignition key.
3. Remove the outer chrome nut securing the ignition switch to the mounting plate (**Figure 163**).
4. Push the ignition switch through the cover (toward the inside) and remove it from the mounting plate (**Figure 163**).
5. Label and disconnect the electrical connectors from the switch; refer to the wiring diagrams at the end this manual.
6. Installation is the reverse of the preceding steps.
7. Check the ignition/light switch for proper operation.

Removal/installation (1992-1993 models)

1. Disconnect the negative battery cable as described in this chapter.
2. Remove the ignition key.
3. Remove the outer chrome nut (A, **Figure 164**) securing the ignition switch to the mounting plate.
4. Loosen the enrichener cable nut on the backside of the cable bracket (B, **Figure 164**). Remove the enrichener cable out of the cable slot in bracket.
5. Remove the top center engine mount bracket Torx screw (C, **Figure 164**) and remove the enrichener cable bracket. On 1200 models remove the horn and bracket.
6. Remove the ignition switch locknut (**Figure 165**). Remove the switch, switch cover and trim plate off of the top center engine mount bracket.

7. Label and disconnect the electrical connectors from the switch; refer to the wiring diagrams at the end this manual.
8. Remove the ignition switch.
9. Installation is the reverse of the preceding steps while noting the following.
 - a. Tighten the ignition switch locknut to 72 in.-lb. (8 N•m).
 - b. Tighten the top center engine mount bracket Torx screw to 60-120 in.-lb. (7-14 N•m).
 - c. Check the ignition/light switch for proper operation.

Removal/installation (1994 models)

1. Disconnect the negative battery cable as described in this chapter.
2. Remove the ignition key.
3. Remove the fuel tank as described in Chapter Seven.
4. Cut the two main wiring harness cable straps. Discard the cable straps.
5. The enricher cable hex nut uses left-hand threads. Turn the nut clockwise to remove it. Loosen the enricher cable nut on the backside of the cable bracket. Then remove the enricher cable from the cable slot in bracket.
6. Remove the top center engine mount bracket Torx screw and remove the enricher cable bracket. On 1200 models remove the horn and bracket.
7. Remove the outer chrome nut (**Figure 166**) securing the ignition switch to the mounting plate.
8. Remove the ignition switch locknut and the ignition switch cover.
9. Remove the ignition switch from the switch cover.
10. If replacing the ignition switch, remove the ignition switch harness cover and cut the switch wires 3 in. (80 mm) from the switch.
11. Install by reversing the removal steps while noting the following:
 - a. To reconnect the new ignition switch, slide the replacement conduit onto the wiring harness. Match the ignition switch and wiring harness color codes, install new butt connectors to the wiring harness and ignition switch wires. Seal the butt splice connectors as described in the *Sealed Butt Connectors* in *Electrical Connectors* in this chapter.
 - b. Install the ignition switch into the hole in the switch cover so the TOP mark stamped on the switch body faces upward toward the switch position decal.
 - c. Tighten the ignition switch locknut to 72 in.-lb. (8.1 N•m).
 - d. Tighten the top center engine mount bracket Torx screw to 60-120 in.-lb. 7-14 N•m).
 - e. Check the ignition/light switch for proper operation.

Removal/installation (1995-2003 models)

1. Disconnect the negative battery cable as described in this chapter.

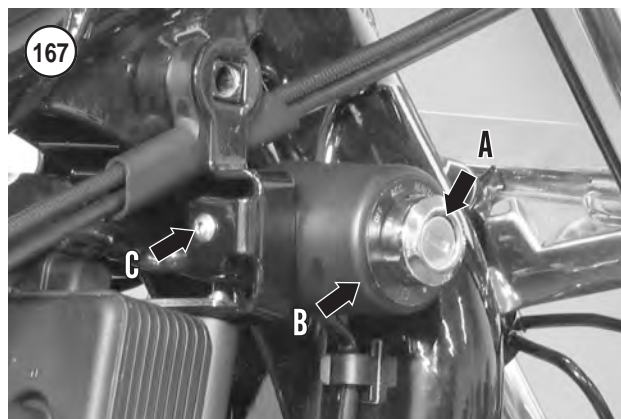
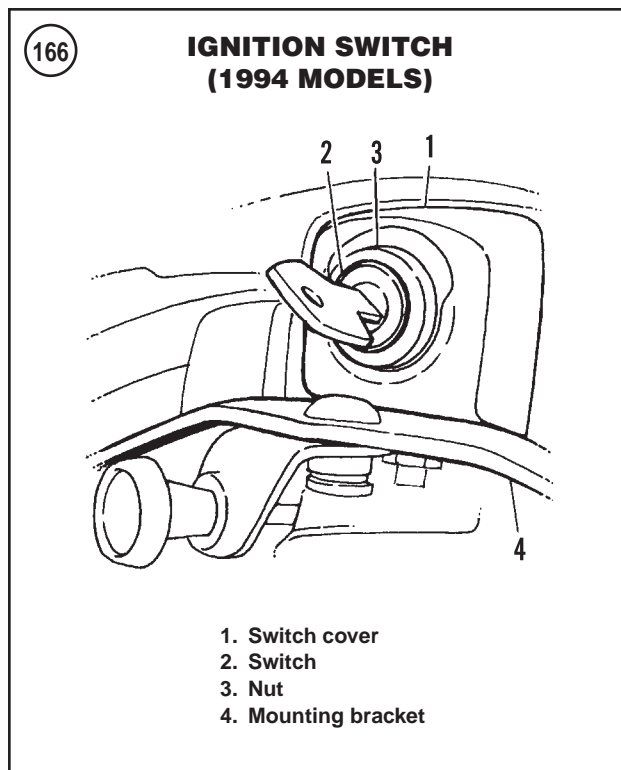

2. Remove the fuel tank as described in Chapter Eleven.
3. Remove the ring nut (A, **Figure 167**).
4. Remove the decal (B, **Figure 167**).
5. Remove the retaining screw (C, **Figure 167**).
6. Remove the switch cover (3, **Figure 168**).
7. Cut the switch wires approximately 3 in. (80 mm) from the switch.
8. Splice the new ignition switch (1, **Figure 168**) to the harness. Splice similar color wires to each other and follow the procedure in *Sealed Butt Connectors* in *Electrcal Connectors* in this chapter.
9. Install the switch by reversing the removal procedure. Tighten the retaining screw (C, **Figure 167**) to 35-45 in.-lb. (4-5 N•m).

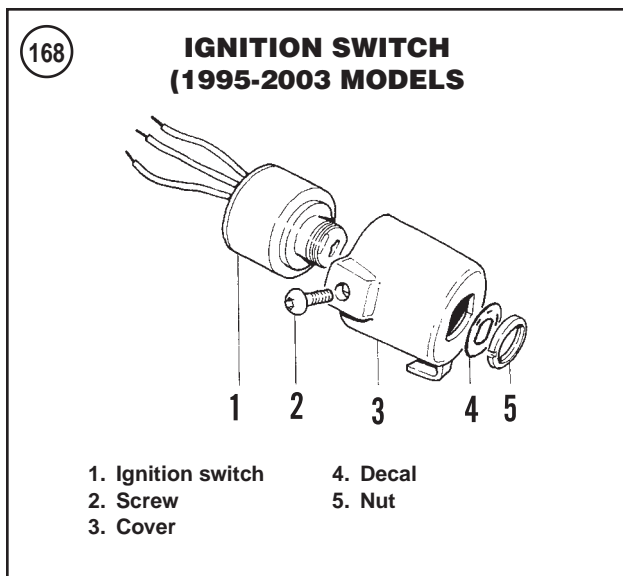

Oil Pressure Switch

Operation

The oil pressure switch is located under the oil filter mounting boss on the crankcase (**Figure 169**). A pressure-actuated diaphragm-type oil pressure switch is used. When the oil pressure is low or when oil is not circulating through a running engine, spring tension inside the switch,

holds the switch contacts closed. This completes the signal light circuit and causes the low oil pressure indicator lamp to light.

The oil pressure signal light should turn on when any of the following occurs:

1. The ignition switch is turned on prior to starting the engine.
2. The engine speed idle is below 1000 rpm.
3. The engine is operating with low oil pressure.
4. Oil is not circulating through the running engine.

NOTE

The oil pressure indicator light may not come on when the ignition switch is turned off then back on immediately. This is due to the oil pressure retained in the oil filter housing. Test the electrical part of the oil pressure switch in the following steps. If the oil pressure switch, indicator lamp and related wiring are in good condition, inspect the lubrication system as described in Chapter Two.

Testing/replacement

1. Disconnect the electrical connector from the switch (**Figure 169**).
2. Turn the ignition switch on.
3. Ground the switch wire to the engine.
4. The low oil pressure indicator lamp on the instrument panel should light.
5. If the indicator lamp does not light, check for a defective indicator lamp, and inspect all wiring between the switch and the indicator lamp.
- 6A. If the oil pressure warning light operates properly, attach the electrical connector to the pressure switch. Make sure the connection is tight and free of oil.
- 6B. If the warning light remains on when the engine is running, shut the engine off. Check the engine lubrication system as described in Chapter Two.
7. To replace the switch, perform the following:
 - a. Unscrew the switch (**Figure 169**) from the engine.
 - b. Unless the new switch has pre-applied sealant, apply pipe sealant to the switch threads prior to installation.
 - c. Install the switch and tighten it to 60-84 in.-lb. (7-9 N•m).
 - d. Test the new switch as described in Steps 1-4.

Neutral Indicator Switch Testing/Replacement

The neutral indicator switch is located on the right side of the crankcase in front of the drive sprocket (**Figure 170**). The neutral indicator light on the instrument panel should light when the ignition is turned on and the transmission is in neutral.

1. Remove the drive sprocket cover as described in Chapter Thirteen.

2. Disconnect the electrical connector from the neutral indicator switch (**Figure 170**).
3. Turn the ignition switch on.
4. Ground the end of the neutral indicator switch wire.
- 5A. If the neutral indicator lamp lights, the neutral switch or attached wire lead is faulty. Verify the condition of the switch wire lead is good, and if so, replace the neutral indicator switch and retest.
- 5B. If the neutral indicator lamp does not light, check for a burned out indicator lamp, faulty wiring or a loose or corroded connection. If necessary, replace the lamp as described in this chapter.
- 6A. If the problem was solved in Steps 3-5, reconnect the electrical connector to the neutral switch. Make sure the connection is tight and free from oil.
- 6B. If the problem was not solved in Steps 3-5, replace the neutral indicator switch as described in the following steps.
7. Remove the drive sprocket as described in Chapter Thirteen.
8. Disconnect the wire lead from the switch (**Figure 170**).
9. Unscrew the switch from the right crankcase.
10. Install the switch and tighten to 36-60 in.-lb. (4.1-6.8 N•m).
11. Reconnect the switch wire lead to the switch.
12. Install the drive sprocket as described in Chapter Thirteen.

Rear Brake Light Switch Testing/Replacement

A hydraulic, normally-open rear brake light switch is used on all models. The rear brake light is located behind the left side cover inline with the rear brake caliper brake hose assembly (**Figure 171**). When the rear brake pedal is applied, hydraulic pressure closes the switch contacts, providing a ground path so the rear brake lamp comes on. If the rear brake lamp does not come on, perform the following:

1. Turn the ignition switch off.
2. Disconnect the electrical connectors from the switch.
3. Connect an ohmmeter between the switch terminals. Check the following:
 - a. Apply the rear brake pedal. There should be continuity.
 - b. Release the rear brake pedal. There should be no continuity.
 - c. If the switch fails either of these tests, replace the switch.
4. If necessary, replace the brake light switch as described in the following steps.
5. Remove the rubber boot from the switch.
6. Place a drip pan under the switch, as some brake fluid will drain out when the switch is removed.
7. Unscrew the switch from the T-fitting on the rear brake line. Make sure to hold the T-fitting with a wrench when performing Step 8.
8. Thread the new switch into the fitting and tighten it to 84-120 in.-lb.(9-14 N•m).
9. Reconnect the switch electrical connectors.
10. Bleed the rear brake as described in Chapter Sixteen.

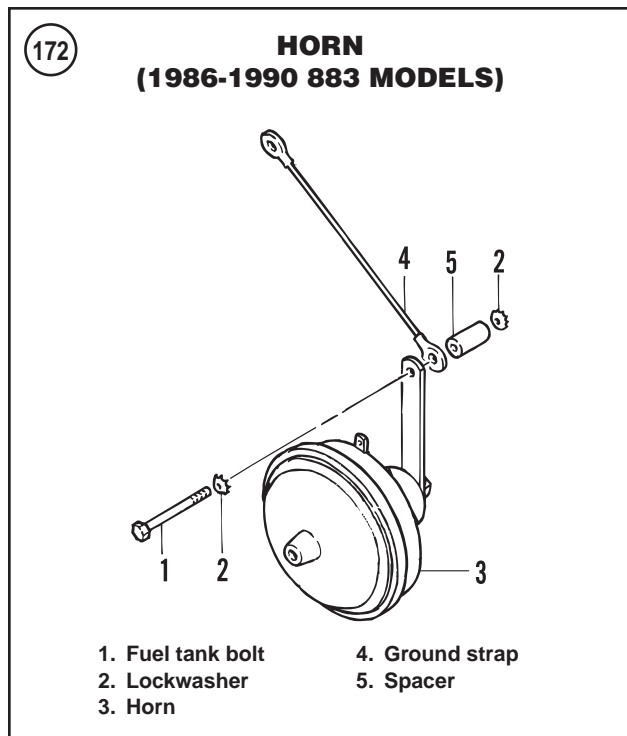

11. Check the rear brake light with the ignition switch turned on and the rear brake applied.

HORN

Testing

1. Label, then disconnect the electrical connectors from the horn.
2. Connect a positive voltmeter test lead to the yellow or yellow/black electrical connector and the negative test lead to ground.
3. Turn the ignition switch to the on position.
4. Press the horn button. If battery voltage is present, the horn is faulty or is not grounded properly. If there is no battery voltage, either the horn switch or the horn wiring is faulty.
5. Replace the horn or horn switch as necessary.

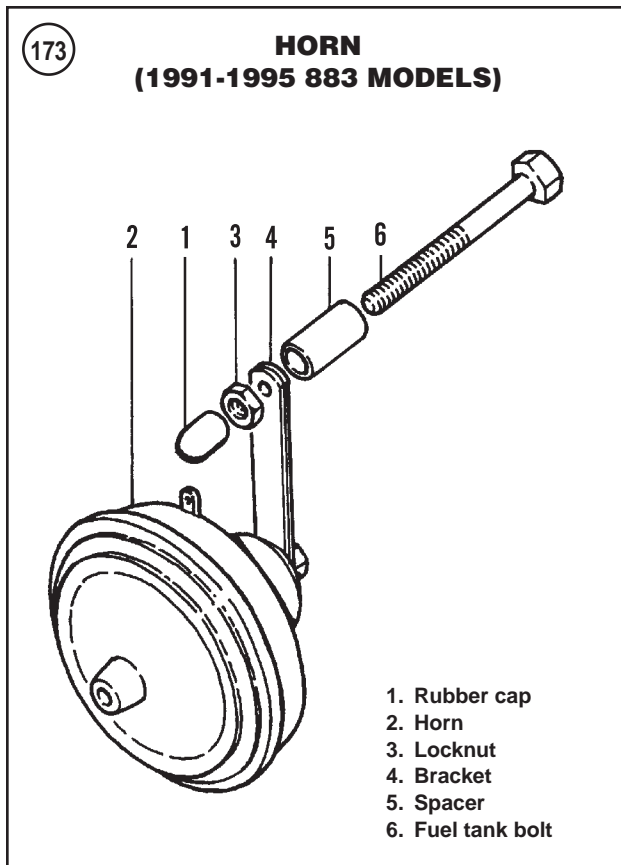

Removal/Installation

1986-1995 883 models

Refer to **Figure 172** or **Figure 173**.

1. Label and then disconnect the horn electrical connector(s) at the horn spade terminals.
2. Remove the rubber cap from the front fuel tank mounting bolt.
- 3A. On 1986-1990 models, remove the front fuel tank mounting bolt.
- 3B. On 1991-1995 models, hold the front fuel tank mounting bolt and remove the horn locknut.
4. Remove the horn, bracket and spacer.
5. Install by reversing the preceding removal steps while noting the following:
 - a. Make sure the electrical connectors and horn spade terminals are free of corrosion.
 - b. Tighten the front fuel tank mounting bolt to the tightening torque specified in **Table 4**.
 - c. Check that the horn operates correctly.

1986-1990 1100 and 1200 models

Refer to **Figure 174**.

1. Label and then disconnect the horn electrical connectors at the horn spade terminals.
2. Disconnect the ground strap from the support bracket.
3. Remove the bolt (4, **Figure 174**), then remove the horn assembly.
4. Remove the nut (10, **Figure 174**) and separate the horn and cover.
5. Install by reversing the removal steps. Note the following:
 - a. Make sure the electrical connectors and horn spade terminals are free of corrosion.
 - b. Check that the horn operates correctly.

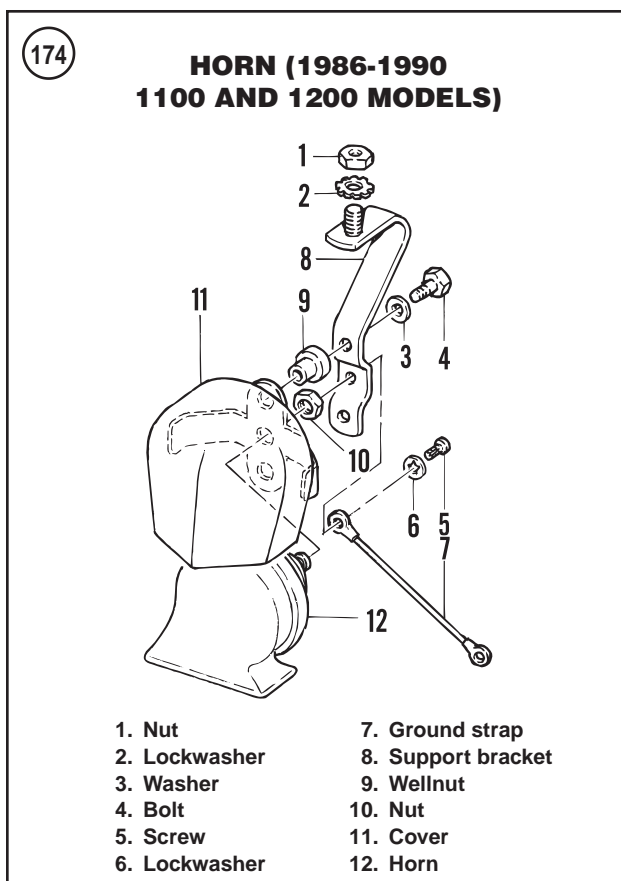

All 1991-2003 1200 models except 1200C models

Refer to **Figure 175**.

1. Label and then disconnect the horn electrical connectors at the horn spade terminals.
2. Remove the Acorn nut and lockwasher securing the horn assembly to the rubber mount stud.
3. Remove the horn assembly and remove the wire clip from the backside of the horn bracket.
4. Remove the locknut from the recess in the horn bracket. Then remove the horn and tooth lockwasher.
5. Install by reversing the preceding removal steps while noting the following:
 - a. Make sure the electrical connectors and horn spade terminals are free of corrosion.
 - b. Check that the horn operates correctly.

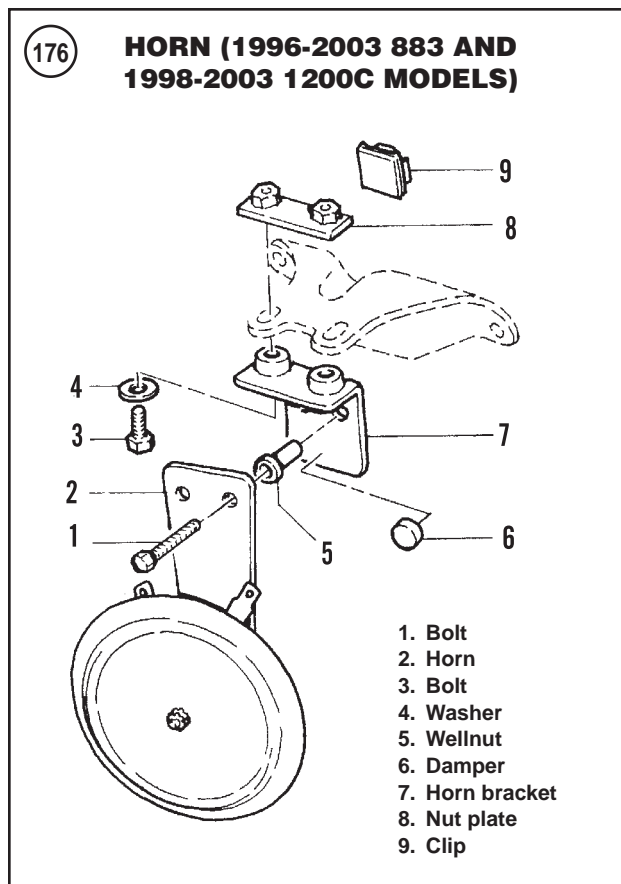
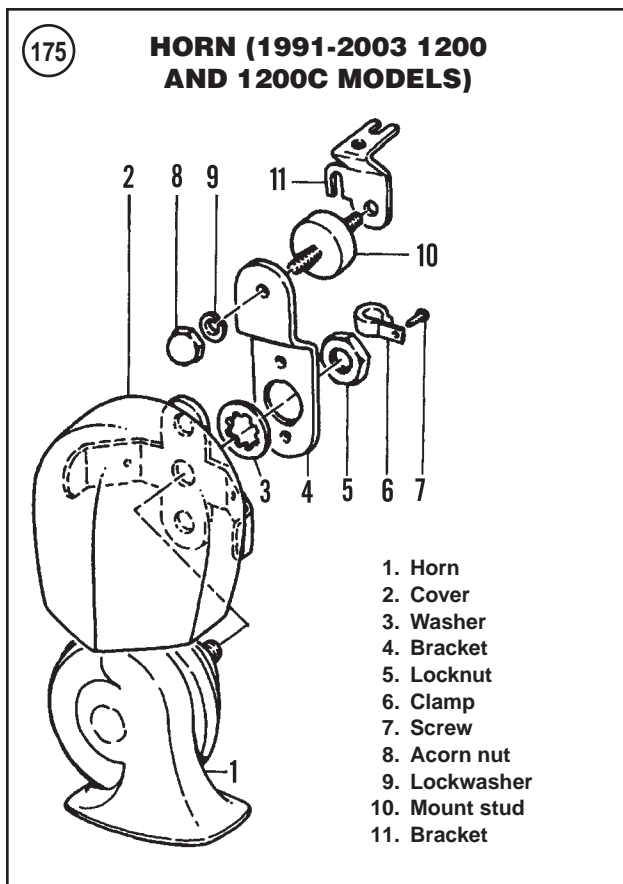

All 1996-2003 and 1998-2003 XL1200S models

Refer to **Figure 176**.

1. Turn the handlebar to the right to access the fork.
2. Label and then disconnect the horn electrical connectors at the horn spade terminals.
3. Remove the bolts that secure the horn to the horn bracket, then remove the horn.
4. Install by reversing the removal steps. Note the following:
 - a. Make sure the electrical connectors and horn spade terminals are free of corrosion.
 - b. Tighten the horn mounting bolts to 6-9 in.-lb. (0.5-1 N•m).
 - c. Check that the horn operates correctly.

ELECTRICAL BRACKET

Removal/Installation

1994-1997 models

The electrical bracket contains the turn signal module, circuit breakers or fuses, starter relay and main circuit breaker. Refer to **Figure 177** and **Figure 178**.

1. Disconnect the negative battery cable as described in this chapter.
2. Remove the seat (Chapter Seventeen).

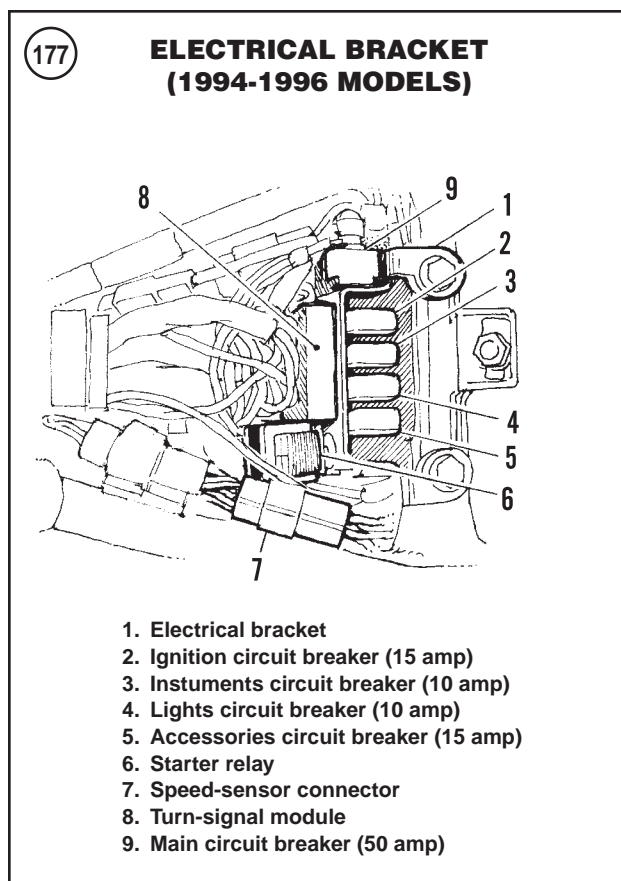

178

ELECTRICAL BRACKET (1997 MODELS)

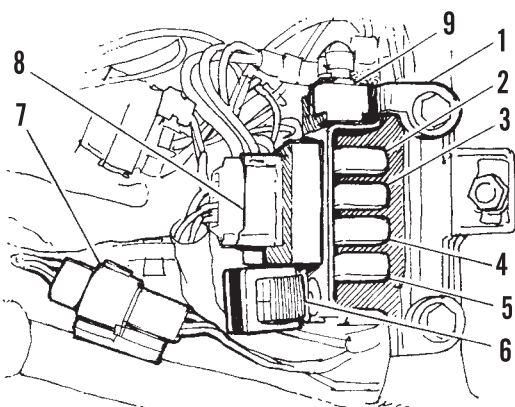

1. Electrical bracket
2. Ignition circuit breaker (15 amp)
3. Instruments circuit breaker (10 amp)
4. Lights circuit breaker (10 amp)
5. Accessories circuit breaker (15 amp)
6. Starter relay
7. Speed-sensor connector
8. Turn-signal module
9. Main circuit breaker (30 amp)

179

ELECTRICAL BRACKET (1998-2003 MODELS)

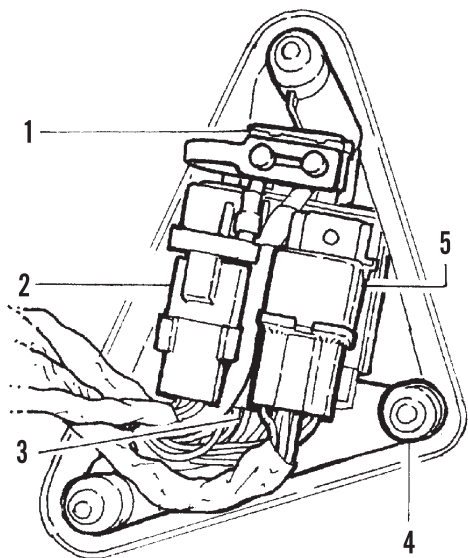

1. Main circuit breaker (30 amp)
2. Data link connector (1200S models only)
3. Fuse block
4. Mount
5. Starter relay

180

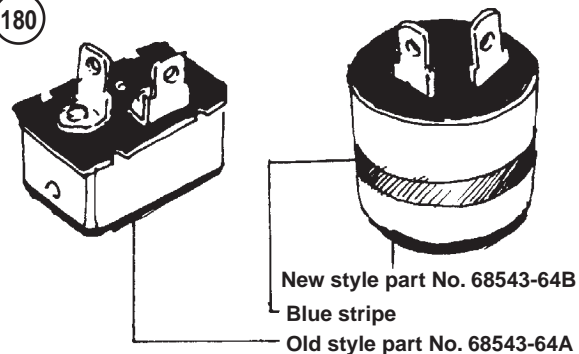

3. Remove the two electrical bracket bolts and lift the electrical bracket from the frame.
4. Remove the wellnuts from the frame.
5. Inspect the rubber wellnuts for cracks, tears or other signs of deterioration. Replace them as necessary.
6. Installation is the reverse of removal. Tighten the electrical bracket mounting bolts to 6-9 in.-lb. (0.5-1 N•m).

1998-2003 models

The electrical bracket contains the main circuit breaker, fuse block, and starter relay. On 1200S models, the data link connector is also on the electrical bracket, which is behind the left side cover. See **Figure 179**.

1. Remove the negative battery cable as described in this chapter.
2. Gently pull the side cover from the motorcycle until the mounts are released from the grommets in the frame.
3. Install by aligning the mounts with the frame grommets. Gently press the side cover until the mounts are secured in the grommets.

12

TURN SIGNAL FLASHER (1986-1990 MODELS)

Replacement

The turn signal flasher is located in the headlight housing behind the sealed beam.

1. Remove the sealed beam as described in *Lighting System* in this chapter.

NOTE

Early 1986 models are equipped with a rectangular shaped flasher. Late 1986-1990 models are equipped with a round flasher with a blue stripe. Refer to **Figure 180**. Do not use original equipment round flashers not marked with a blue stripe. These are four-way flashers that will cause incorrect turn signal operation. Early 1986 models can use the later style blue-stripped flasher

2. Remove the flasher and insert a new unit. Check the turn signal operation.
3. Make sure the flasher is positioned in the headlight housing so the electrical terminals face toward the rear of the motorcycle.

CAUTION

Installing the flasher with the terminals pointing forward may damage the terminals if they contact the headlight sealed beam.

TURN SIGNAL MODULE (1991-2003 MODELS)

All 1991-2003 models are equipped with a turn signal module, an electronic microprocessor that controls the turn signals and the four-way hazard flasher. The turn signal module receives its information from the speedometer and turn signal switches.

Removal/Installation

1991-1993 models

On 1991-1993 models, the turn signal module (**Figure 181**) is mounted on the inboard side of the ignition control module bracket (**Figure 182**).

1. Remove the seat.
2. Disconnect the negative battery cable as described in this chapter.
3. Remove the turn signal module mounting bolt.
4. Disconnect the module electrical connector.
5. Reverse the steps for installation.

1994-1996 models

On 1994-1996 models, the module (**Figure 183**) is mounted on the front right side of the electrical bracket under the seat.

1. Remove the seat (Chapter Seventeen).
2. Disconnect the negative battery cable as described in this chapter.
3. Remove the bolts securing the electrical bracket (**Figure 184**) to the frame. Lift the electrical bracket out of the frame.
4. Locate the 8-pin Deutsch connector on the left side of the electrical bracket. Push the connector up and disconnect its clip from the T-stud.
5. Disconnect the turn signal module plug from its electrical connector.
6. Cut the cable straps securing the module to the electrical bracket. Note the position of the cable straps as they are routed through the electrical bracket for reassembly. Remove the module and discard the cable straps.
7. Position the new cable straps through the holes in the front of the electrical bracket.

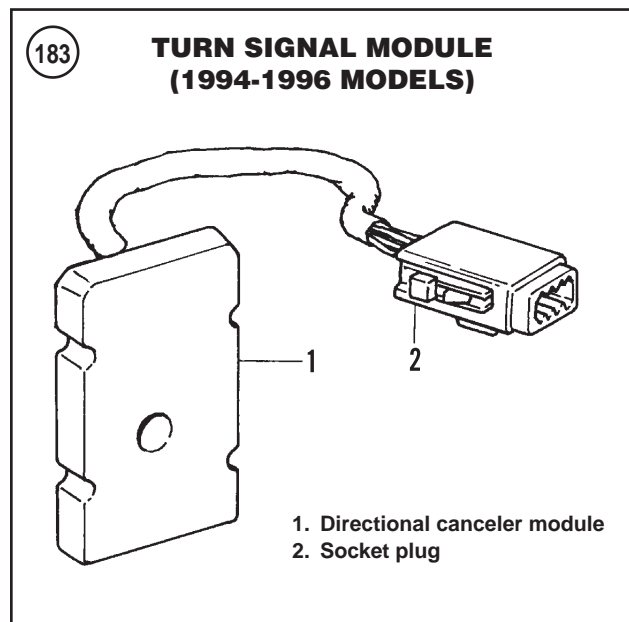
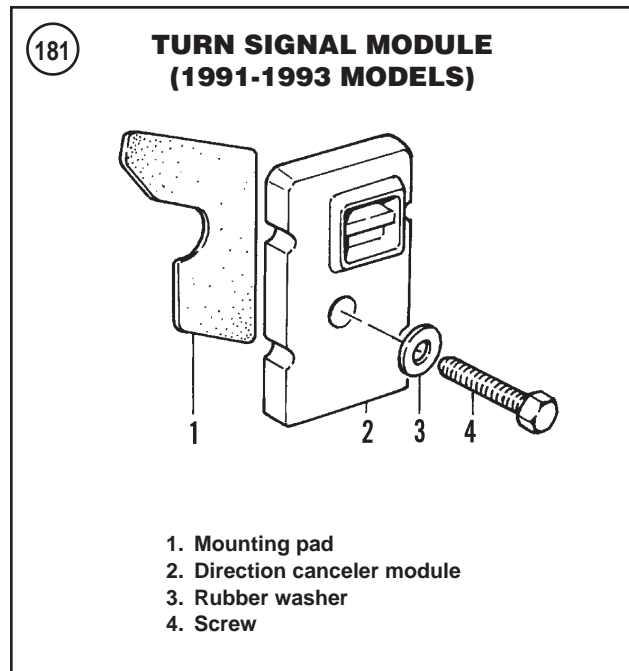

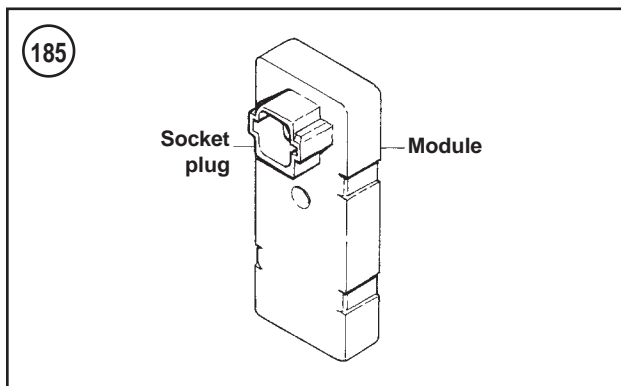
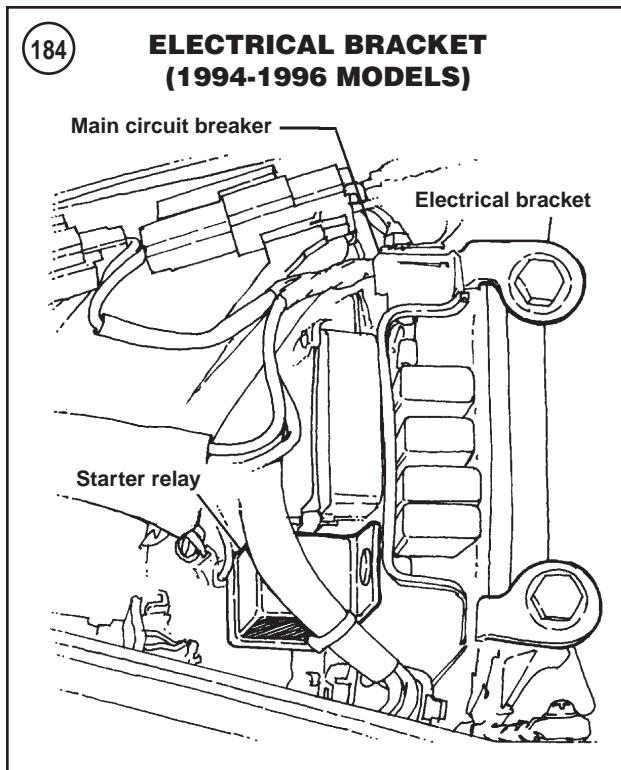

8. Position the new turn signal module against the front of the electrical bracket so that the flat side faces out and the plug end faces down.

9. Wrap the cables around the two grooves in the side of the module, then connect and tighten the cables. Cut off cable excess.

10. Reconnect the turn signal module plug to the electrical connector.

11. Position the large end of the attachment clip end slot over the T-stud on the electrical bracket. Push the connector assembly down and engage small end of slot.

12. Install electrical bracket mounting bolts and tighten securely.

13. Check that the turn signal and flasher systems work properly.

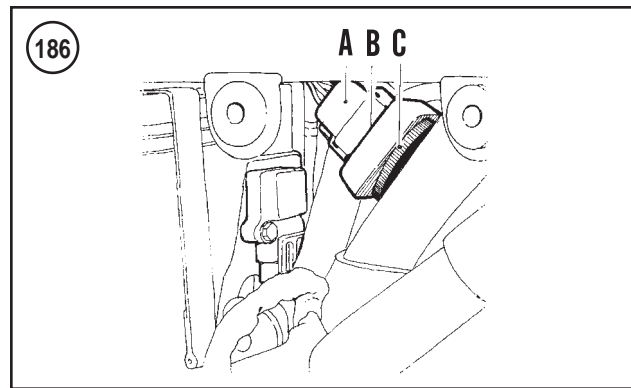

1997 models

On 1997 models, the turn signal module (**Figure 185**) is mounted on the electrical bracket under the seat.

1. Remove the seat (Chapter Seventeen).
2. Disconnect the negative battery cable as described in this chapter.
3. Remove the bolts securing the electrical bracket (1, **Figure 178**) to the frame.
4. Depress the external latches on the 8-terminal Deutsch connector and remove the connector from the turn-signal module (8, **Figure 178**).
5. Remove the mounting screw securing the module to the bracket and remove the turn signal module.
6. Position the new turn signal module against the bracket, and install the mounting screw. Tighten the turn signal module mounting screw to 36-60 in.-lb. (4-7 N•m).
7. Reconnect the 8-terminal harness connector to the turn signal module plug.
8. Install the electrical bracket. Tighten the electrical bracket mounting bolt to 6-9 in.-lb. (0.5-1 N•m).
9. Check that the turn signal and flasher systems work properly.

1998-2003 models

On 1998-2003 models, the module (**Figure 185**) is mounted on the rear fender.

1. Remove the seat (Chapter Seventeen).
2. Disconnect the negative battery cable as described in this chapter.
3. On 1200S models, remove the bolts securing the electrical bracket to the frame. Lift the bracket from the frame crossmembers under the seat.
4. Depress the external latches on the 8-terminal Deutsch connector (A, **Figure 186**) and remove the connector from the turn signal module (B).
5. Remove the mounting screw securing the module to the rear fender and remove the turn signal module.
6. Position the new turn signal module against the rear fender, and install the mounting screw. Be sure the rubber damper (C, **Figure 186**) is in place behind the module.

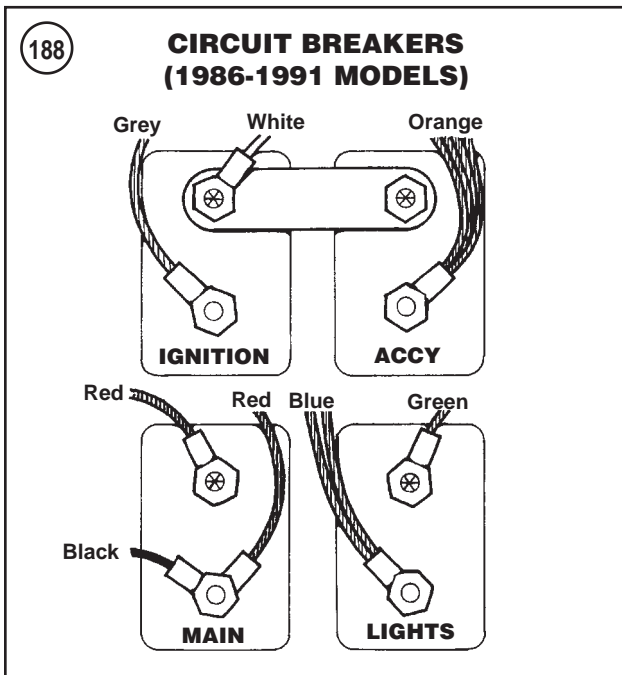

Tighten the turn signal module mounting screw to 36-60 in.-lb. (4-7 N•m).

7. Reconnect the 8-terminal harness connector to the turn-signal-module plug.

8. On 1200S models, secure the electrical bracket to the frame. Torque the electrical bracket mounting bolts to 6-9 in.-lb. (0.5-1 N•m).

9. Check that the turn signal and flasher systems work properly.

Turn Signal Module Troubleshooting

Refer to Chapter Two.

CIRCUIT BREAKERS (1986-1997 MODELS)

All 1986-1997 models use circuit breakers to protect the electrical system. Circuit breaker ratings for the various circuits are listed in **Table 1**.

Whenever a failure occurs in any part of the electrical system, each circuit breaker is self-resetting and will auto-

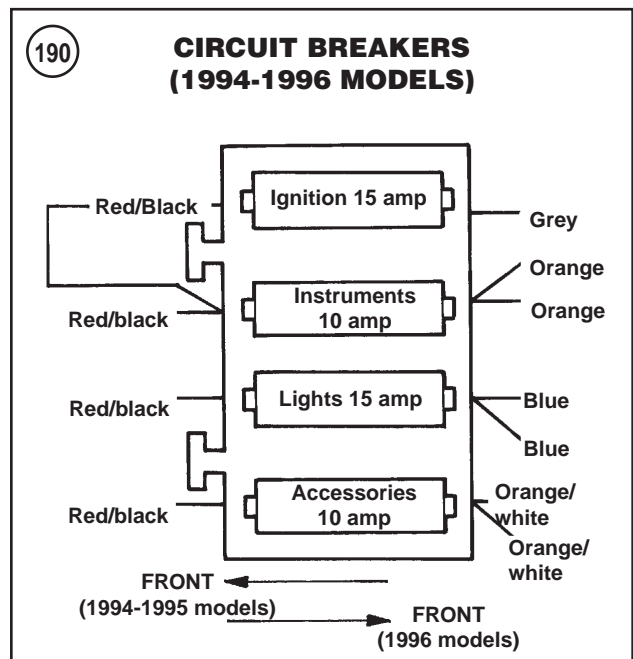
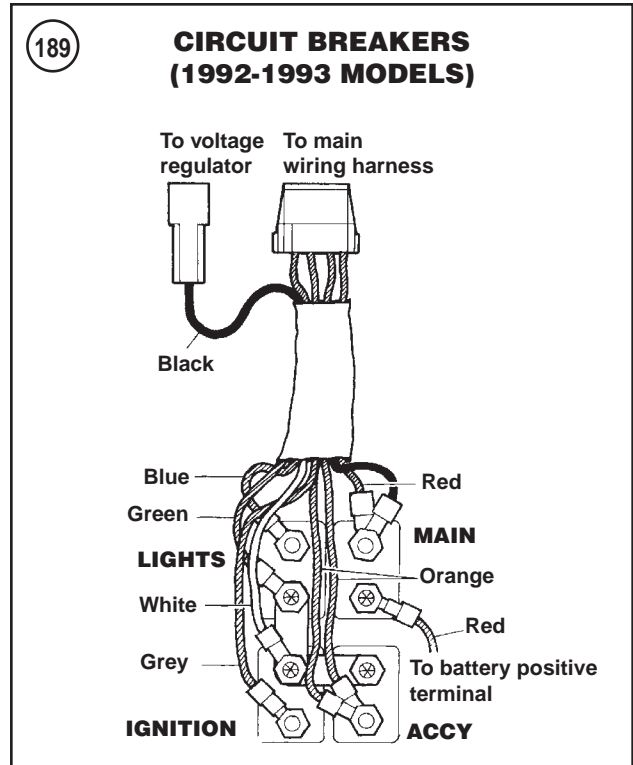

matically return power to the circuit when the electrical fault is corrected.

CAUTION

If an electrical fault on circuit-breaker equipped models is not found and corrected, the breakers will cycle on and off continuously. This will cause the motorcycle to run erratically and eventually discharge the battery.

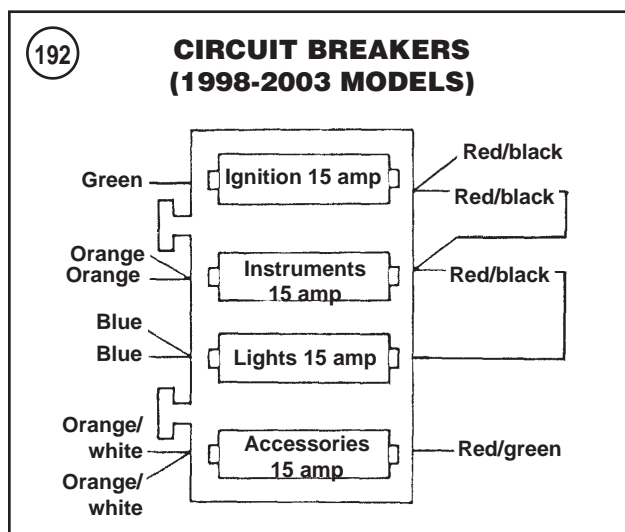
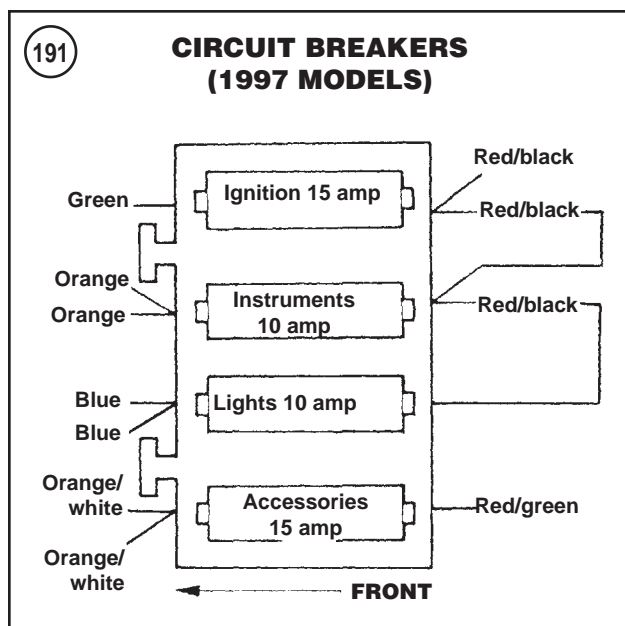

Most faults can be traced to a short circuit in the wiring. This may be caused by worn-through insulation or by a wire that has worked loose and shorted to ground. Occasionally, the electrical overload that causes the circuit breaker to trip may occur in a switch or motor. Use the wiring diagrams at the end of the manual to determine which circuits are protected by each circuit breaker.

All 1986-1993 models have four circuit breakers mounted on the front side of the rear fender underneath the seat (Figure 187). Refer to Figure 188 or Figure 189. Disconnect the negative battery cable prior to servicing the circuit breakers.

All 1994-1997 models have five circuit breakers. The ignition, instruments, lights and accessories circuit breakers are mounted in the circuit breaker block installed in the electrical bracket mounted underneath the seat (Figure 190 or Figure 191). The main circuit breaker is mounted in the electrical bracket on the right side of the circuit breaker block

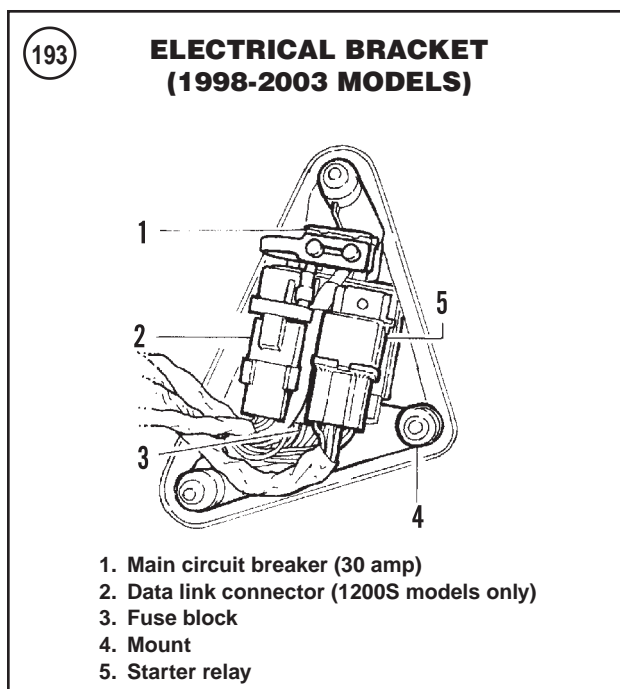

(Figure 184). Disconnect the negative battery cable as described in this chapter prior to servicing the circuit breakers.

FUSES (1998-2003 MODELS)

All 1998-2003 models use fuses (Figure 192) to protect electrical circuits. Fuse ratings for each circuit are listed in Table 1.

Usually a blown fuse can be traced to a short circuit in the wiring. This may be caused by worn-through insulation or by a wire that has worked loose and shorted to ground. Occasionally, the electrical overload that causes the fuse to blow may occur in a switch or motor. Use the wiring diagrams at the end of this manual to determine which circuits are protected by each fuse.

The ignition, instruments, lights and accessories circuit fuses are mounted in the fuse block (3, Figure 193), which is behind the starter relay (5) in the electrical bracket. Pull up on the latch to release the fuse box. The main circuit breaker is behind the cover on the electrical bracket.

Whenever a fuse blows, correct the electrical fault before replacing the fuse.

ELECTRICAL CONNECTOR SERVICE

Deutsch Electrical Connectors Socket

Terminal removal/installation

This procedure is shown on a 12-pin Duetsch connector and is the same for 2-, 3-, 4- and 6-pin Duetsch connectors.

Refer to Figure 194 and Figure 195.

194

DEUTSCH CONNECTORS (2-PIN, 3-PIN AND 4-PIN)

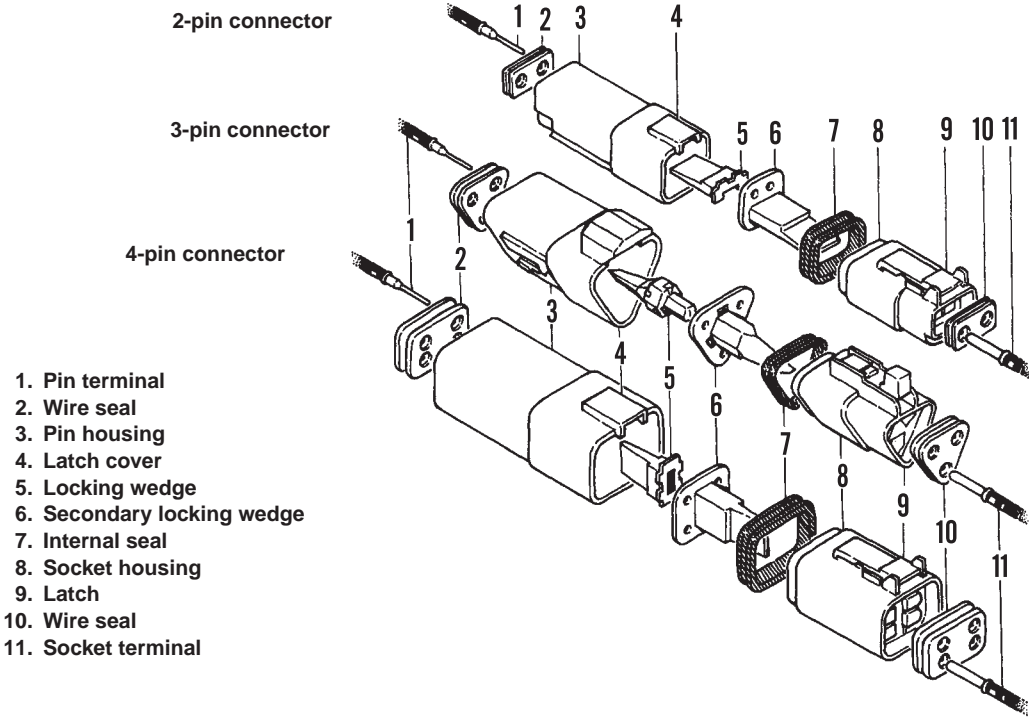

- 1. Pin terminal
- 2. Wire seal
- 3. Pin housing
- 4. Latch cover
- 5. Locking wedge
- 6. Secondary locking wedge
- 7. Internal seal
- 8. Socket housing
- 9. Latch
- 10. Wire seal
- 11. Socket terminal

195

DEUTSCH CONNECTOR (12-PIN)

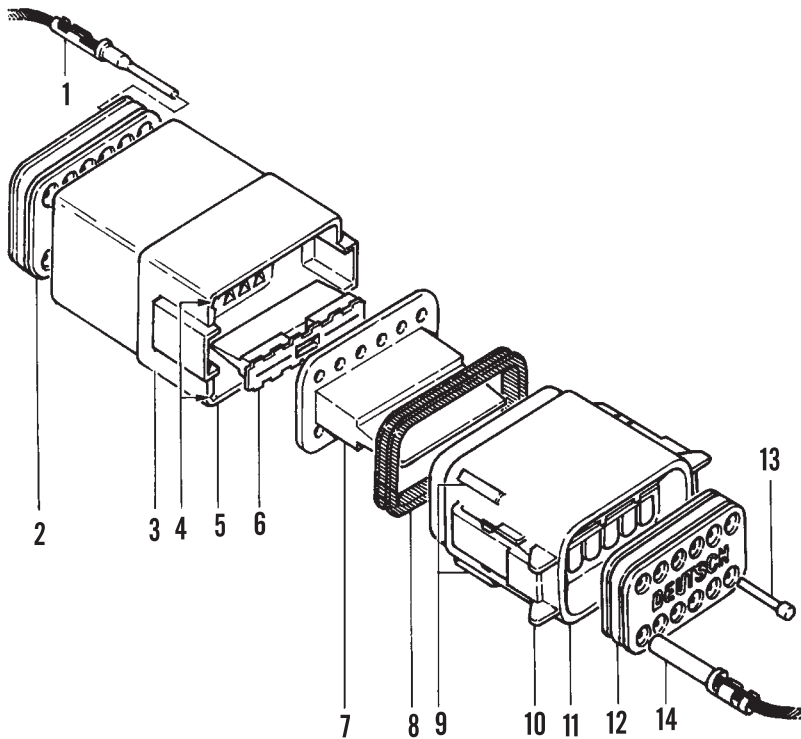

- 1. Pin terminal
- 2. Wire seal
- 3. Pin housing
- 4. Latch cover
- 5. Alignment grooves
- 6. Locking wedge
- 7. Secondary locking wedge
- 8. Internal seal
- 9. Alignment tabs
- 10. External latch
- 11. Socket
- 12. Wire seal
- 13. Seal pin
- 14. Socket terminal

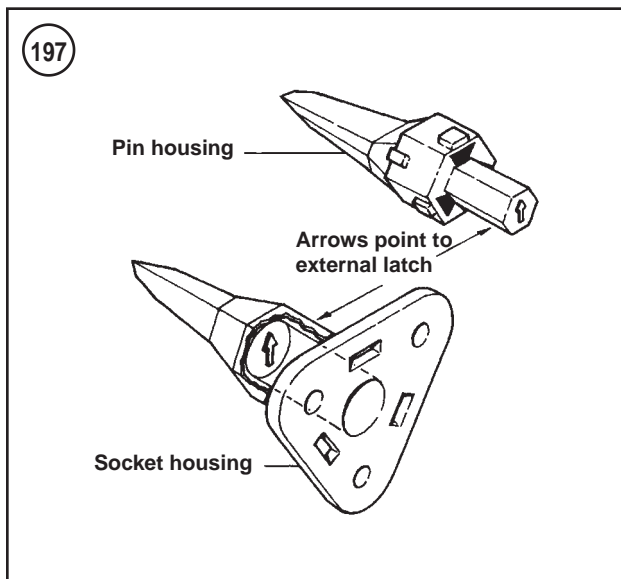
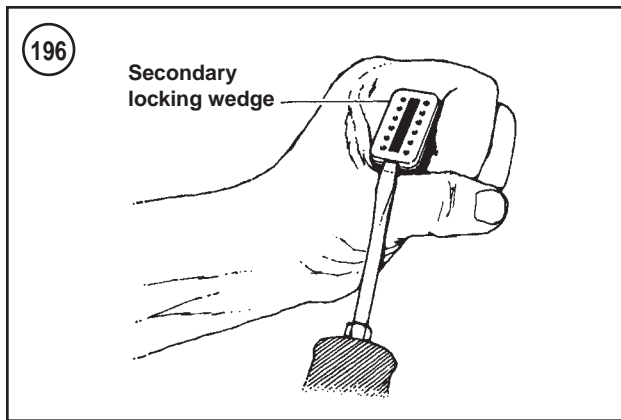

1. Disconnect the negative battery cable as described in this chapter.
2. Disconnect the connector housing.
3. Remove the secondary locking wedge as follows:
 - a. Locate the secondary locking wedge in **Figure 194** or **Figure 195**.
 - b. Insert a wide-blade screwdriver between the socket housing and the locking wedge. Turn the screwdriver 90° to force the wedge up (**Figure 196**).
 - c. Remove the secondary locking wedge.
4. Press the terminal latches inside the socket housing and remove the socket terminal through the holes in the rear wire seal.
5. Repeat Step 3 for each socket terminal.
6. If necessary, remove the wire seal.
7. Install the wire seal into the socket housing if it was removed.
8. Hold onto the socket housing and insert the socket terminals through the holes in the wire seal so they enter the correct chamber hole. Continue until the socket terminal locks into place. Then lightly tug on the wire to make sure it is locked into place.

9. Set the internal seal onto the socket housing if it was removed.

NOTE

*With the exception of the 3-pin Deutsch connector, all of the secondary locking wedges are symmetrical. When assembling the 3-pin connector, install the connector so the arrow on the secondary locking wedge is pointing toward the external latch as shown in **Figure 197**.*

NOTE

If the secondary locking wedge does not slide into position easily, one or more of the socket terminals are not installed correctly. Correct the problem before trying to lock the wedge into the socket.

10. Install the secondary locking wedge into the socket housing as shown in **Figure 194** or **Figure 195**. Press the secondary locking wedge down until it locks into place.

Pin terminal removal/installation

This procedure is shown on a 12-pin Deutsch connector and relates to all of the Deutsch connectors.

Refer to **Figure 194** and **Figure 195**.

1. Disconnect the negative battery cable as described in this chapter.
2. Disconnect the connector housing.
3. Use needlenose pliers to remove the locking wedge.
4. Lightly press the terminal latches inside the pin housing and remove the pin terminal(s) through the holes in the rear wire seal.
5. Repeat Step 3 for each socket terminal.
6. If necessary, remove the wire seal.
7. Install the wire seal into the socket housing if it was removed.
8. Hold onto the pin housing and insert the pin terminals through the holes in the wire seal so they enter their correct chamber hole. Continue until the pin terminal locks into place. Then lightly tug on the wire to make sure it is locked into place.

NOTE

*With the exception of the 3-pin Deutsch connector, all of the secondary locking wedges are symmetrical. When assembling the 3-pin connector, install the connector so the arrow on the secondary locking wedge is pointing toward the external latch as shown in **Figure 197**.*

NOTE

If the locking wedge does not slide into position easily, one or more of the pin terminals are not installed correctly. Correct the problem before trying to lock the wedge into the socket.

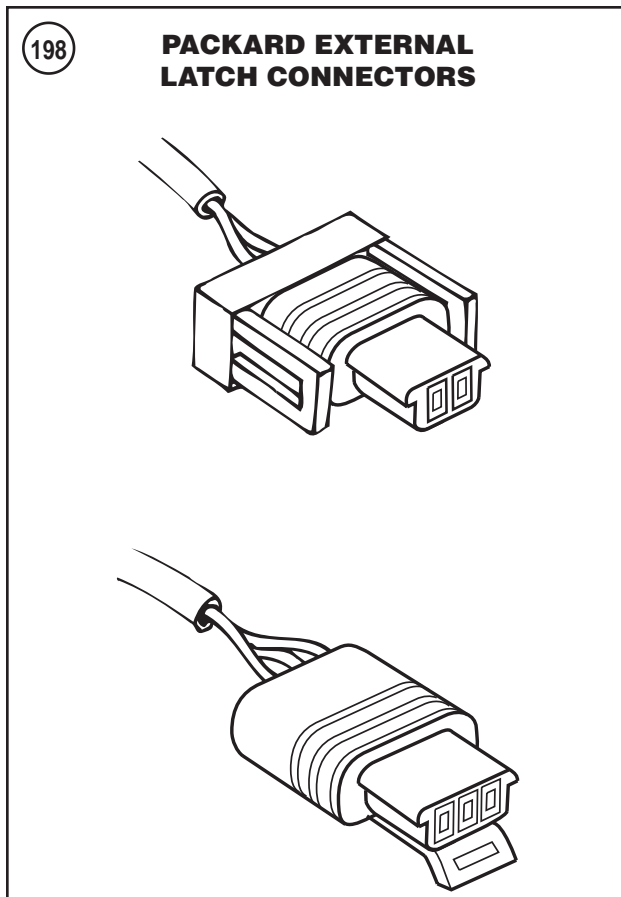

9. Install the locking wedge into the pin housing as shown in **Figure 194** or **Figure 195**. Press the secondary locking wedge down until it locks into place. When properly installed, the wedge will fit into the pin housing center groove.

Packard Electrical Connectors External Latch Type Removal/Installation

This procedure shows how to remove and install the electrical terminals from the external latch type connectors with pull-to-seat terminals (**Figure 198**).

1. Disconnect the negative battery cable as described in this chapter.
2. Bend back the external latch(es) slightly and separate the connector.
3. Look into the mating end of the connector (A, **Figure 199**) and locate the locking tang in the middle chamber and on the external latch side of connector. On locking ear connectors, the tang is on the side opposite the ear.
4. Insert the point of a one-inch safety pin about 1/8 in. into the middle chamber (B, **Figure 199**). Pivot the end of the safety pin up toward the terminal body until a click is heard. Repeat this step several times. The click is the tang returning to the locked position as it slips from the point of the safety pin. Continue to pick at the tang until the clicking stops and the safety pin seems to slide in at a slightly greater depth indicating the tang has been depressed.
5. Remove the safety pin, push the wire end of the lead and remove the lead from the connector (C, **Figure 199**). If additional slack is necessary, pull back on the harness conduit and remove the wire seal at the back of the connector.
6. To install the terminal and wire back into the connector, use a thin flat blade of an X-Acto knife to carefully bend the tang away from the terminal (D, **Figure 199**).
7. Carefully pull the lead and terminal into the connector until a click is heard indicating the terminal is seated correctly within the connector. Gently push on the lead to ensure the terminal is correctly seated.
8. If necessary, install the wire seal and push the harness conduit back into position on the backside of the connector.
9. Push the socket halves together until the latch(es) are locked together.

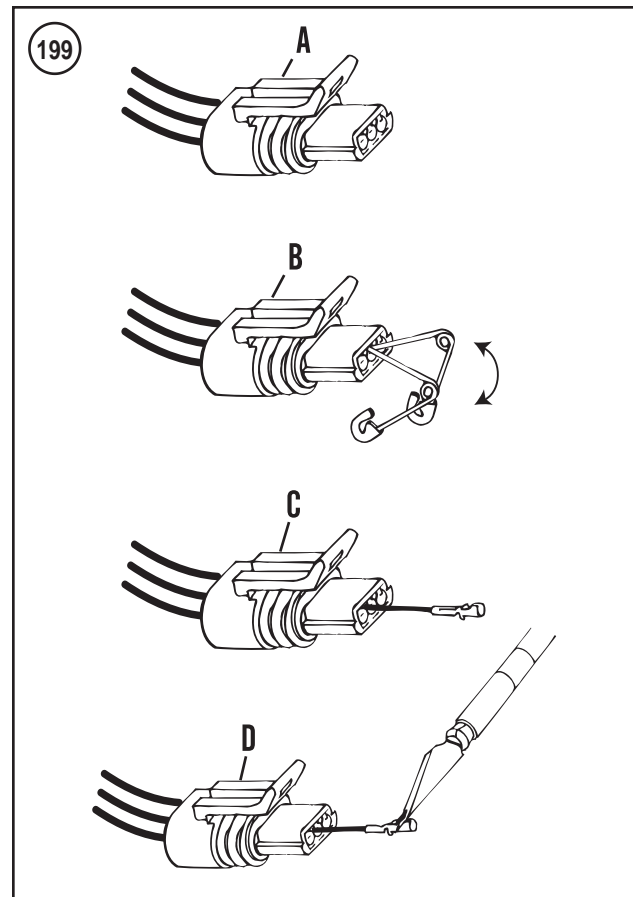

Amp Electrical Connectors Socket and Pin Terminals Removal/Installation

This procedure shows how to remove and install the socket and pin terminals from the pin and socket housing connector. This procedure relates to all of the Amp connectors (2-, 4- and 6-pin).

Refer to **Figure 200**.

200

AMP MULTILOCK CONNECTORS

3-pin connector

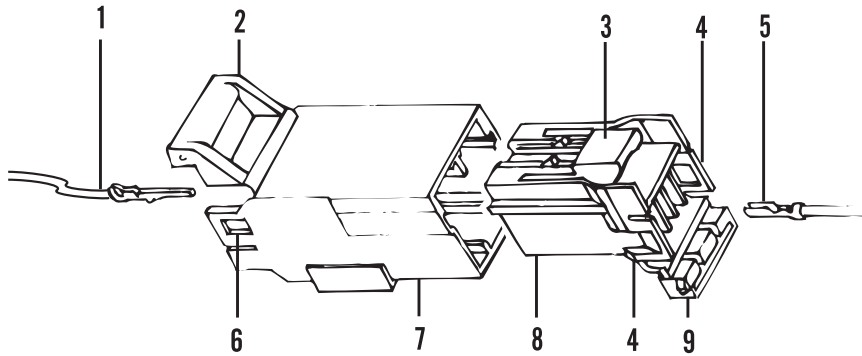

6-pin connector

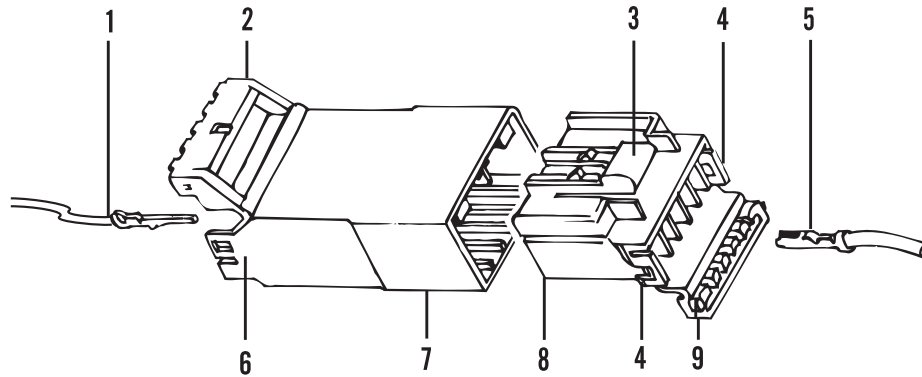

10-pin connector

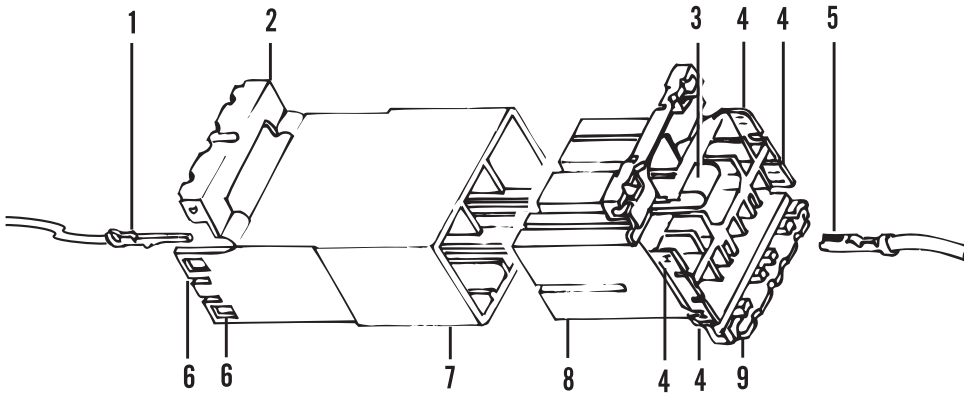

- 1. Pin terminal
- 2. Secondary lock
- 3. Button
- 4. Latch
- 5. Socket terminal
- 6. Latch
- 7. Pin housing
- 8. Socket housing
- 9. Secondary lock

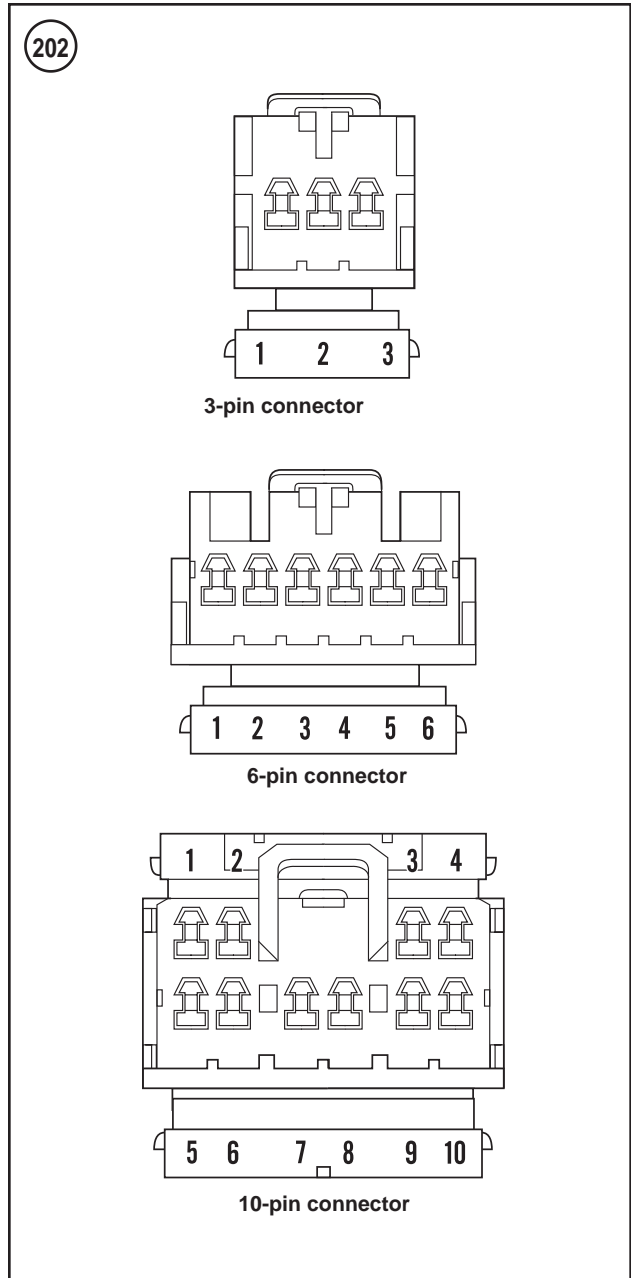
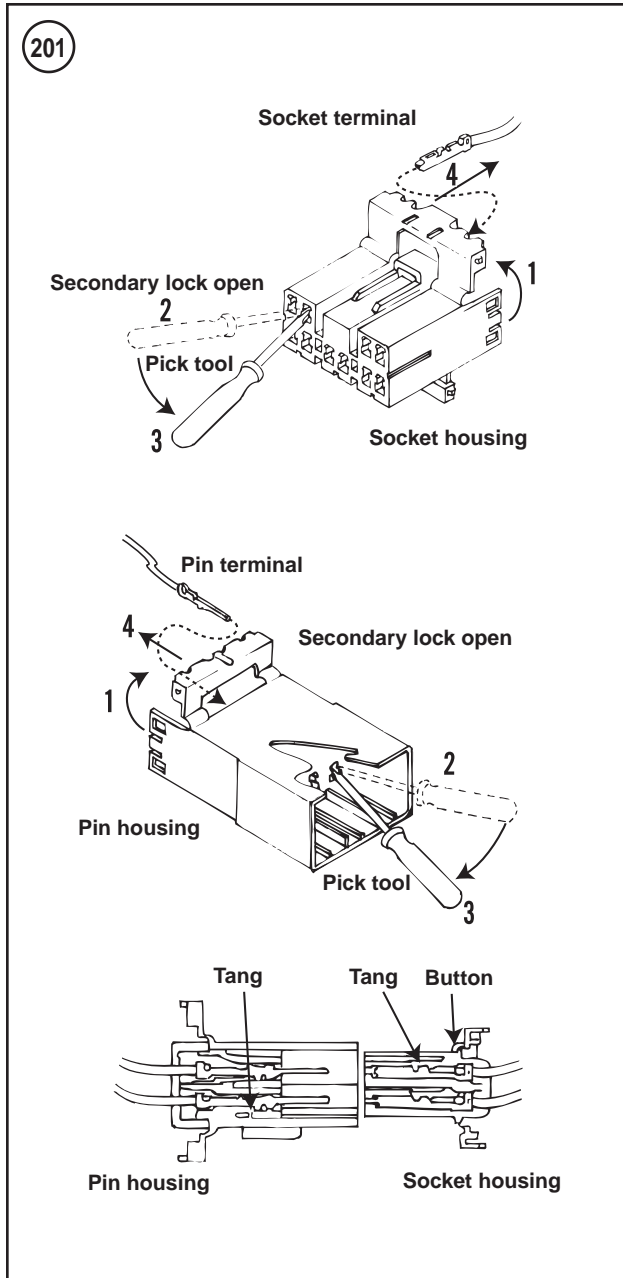

1. Disconnect the negative battery cable as described in this chapter.
2. Press the button on the socket on the terminal side and pull the connector apart.
3. Slightly bend the latch back and free one side of the secondary lock. Repeat this step for the other side.
4. Rotate the secondary lock (**Figure 201**) out on the hinge to access the terminals within the connector.

NOTE

Do not pull too hard on the wire until the tang is released or the terminal will be difficult to remove.

5. Insert a pick tool (2, **Figure 201**) into the flat edge of the terminal cavity until it stops. Pivot the pick tool away (3,

Figure 201) from the terminal and gently pull on the wire to pull the terminal (4) from the terminal cavity. Note the wire location number on the connector (**Figure 202**, typical).

NOTE

The release button used to separate the connectors is at the top of the connector.

6. The tang in the chamber engages the pin terminal slot to lock the terminal into position. The tangs (**Figure 201**) are located as follows:

- a. On the pin housing side, the tangs are located at the bottom of each chamber. The pin terminal slot, on the side opposite the crimp tails, must face downward.

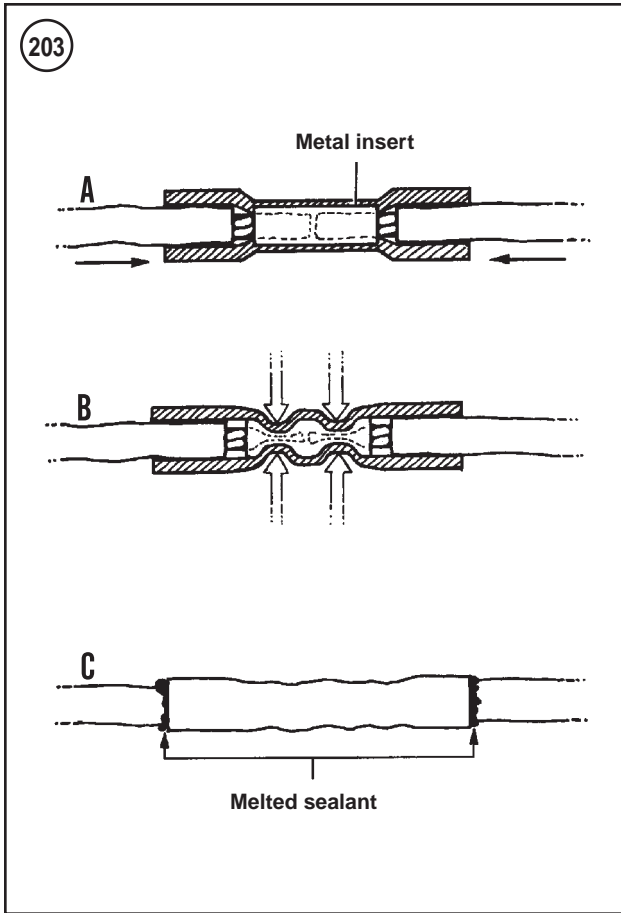

- b. On the socket housing side, the tangs are located at the top of each chamber. The pin terminal slot, on the same side as the crimp tails, must face upward.
- 7. On the secondary lock side of the connector, push the wire and terminal into the correct location until it snaps into place. Gently pull on the lead to ensure the terminal is correctly seated.
- 8. Rotate the hinged secondary lock down and inward until the tabs are fully engaged with the latches on both sides of the connector. Pull upward to make sure the tabs are locked in place.
- 9. Insert the socket housing into the pin housing and push it in until it locks into place.

Sealed Butt Connectors

Replacement of the ignition switch will require sealed butt connectors to connect the new switch wiring to the existing wiring.

Refer to **Figure 203** when installing a sealed butt connector.

NOTE

Stagger the position of the connectors so they are not side-by-side.

WIRING DIAGRAMS

Color wiring diagrams for all models are located at the end of this manual.

Table 1 ELECTRICAL SPECIFICATIONS

| | |
|------------------------|------------------------|
| Battery capacity | 12 volt, 9 amp hr. |
| Ignition coil | |
| Primary resistance | |
| 1200S models | 0.4-0.6 ohms |
| All other models | 2.5-3.1 ohms |
| Secondary resistance | |
| 1986-1992 models | |
| 1993-2003 models | |
| 1200S models | 11,500-12,700 ohms |
| All other models | 10,000-12,500 ohms |
| Alternator | |
| Stator coil resistance | 0.2-0.4 ohms |
| AC voltage output | 19-26 VAC per 1000 rpm |
| Voltage regulator | |
| Voltage output | |
| 1986-1993 models | 13.8-15 VDC @ 75° F |
| 1994-2003 models | 14.3-14.7 VDC @ 75° F |
| Amps @ 3600 rpm | |
| 1986-1990 models | 19 amps |
| 1991-2003 models | 22 amps |
| | (continued) |

Table 1 ELECTRICAL SPECIFICATIONS (continued)

| | |
|-------------------------|--------|
| Circuit breakers | |
| 1986-1993 models | |
| Main | 30 amp |
| Accessory | 15 amp |
| Ignition | 15 amp |
| Lights | 15 amp |
| 1994-1996 models | |
| Main | 50 amp |
| Accessory | 15 amp |
| Ignition | 15 amp |
| Lights | 10 amp |
| Instruments | 10 amp |
| 1997 models | |
| Main | 30 amp |
| Accessory | 15 amp |
| Ignition | 15 amp |
| Lights | 10 amp |
| Instruments | 10 amp |
| Fuses | |
| 1998-2003 models | |
| Main circuit breaker | 30 amp |
| Accessory | 15 amp |
| Ignition | 15 amp |
| Lights | 15 amp |
| Instruments | 15 amp |

Table 2 BATTERY CHARGING RATES/TIMES (APPROXIMATE)

| Voltage | % of charge | 3 amp charger | 6 amp charger | 10 amp charger | 20 amp charger |
|----------------|--------------------|----------------------|----------------------|-----------------------|-----------------------|
| 12.8 | 100% | – | – | – | – |
| 12.6 | 75% | 70 minutes | 34 minutes | 20 minutes | 10 minutes |
| 12.3 | 50% | 2.3 hours | 70 minutes | 40 minutes | 20 minutes |
| 12.0 | 25% | 3.3 hours | 1.6 hours | 1 hour | 30 minutes |
| 11.8 | 0% | 4.5 hours | 2.25 hours | 1.3 hours | 40 minutes |

Table 3 STARTER SPECIFICATIONS

| | |
|--------------------------------------|-------------------------------|
| Brush length (minimum) | |
| 883 and 1100 models | |
| 1986-1994 models | 0.354 in. (8.9 mm) |
| 1995-2003 models | 0.433 in. (11.0 mm) |
| 1200 models | |
| 1988-1990 models | 0.354 in (8.9 mm) |
| 1991-1992 models | 0.413 in. (10.5 mm) |
| 1993-1994 models | 0.354 in. (8.9 mm) |
| 1995-2003 models | 0.433 in. (11.0 mm) |
| Commutator | |
| Diameter (minimum) | 1.141 in. (28.98 mm) |
| runout | 0.16 in. (0.41 mm) |
| Current draw | |
| Normal | 140-180 amps |
| Maximum | 200 amps |
| Maximum no-load current @ 11.5 volts | 90 amps |
| Minimum no-load speed @ 11.5 volts | 3000 rpm |
| Stall torque | |
| 1986-1990 models | |
| 883 models | 5 ft.-lb. (min) @ 2.5 volts |
| 1100 and 1200 models | 8.7 ft.-lb. (min) @ 2.5 volts |
| 1991-1994 models | |
| 883 models | 5 ft.-lb. (min) @ 2.5 volts |
| 1200 models | 8.1 ft.-lb. (min) @ 2.4 volts |
| 1995-2003 models | |
| | 8.1 ft.-lb. (min) @ 2.4 volts |

Table 4 ELECTRICAL SYSTEM TORQUE SPECIFICATIONS

| | ft.-lb. | in.-lb. | N•m |
|--|----------------|----------------|------------|
| Bank angle sensor bolt | – | 15-20 | 1.5-2 |
| Cable nuts | – | 65-80 | 7-9 |
| Cam position sensor | | | |
| 1200S models | – | 12-20 | 1.5-2 |
| Electrical bracket bolt | – | 6-9 | 0.5-1 |
| Fuel tank mounting bolts | | | |
| 1986-1987 models | 19 | – | 26 |
| 1988-1992 models | – | 108 | 12 |
| 1993-2003 models | – | 96-192 | 11-22 |
| Handlebar switch housing screws | – | 35-45 | 4-5 |
| Headlight switch housing system (1996-2003 models) | – | 35-45 | 4-5 |
| Headlight adjust nut | – | 120-240 | 14-27 |
| Headlight bracket bolts | – | 120-192 | 14-22 |
| Horn locknut | | | |
| 1100 and 1200 models except 1200C models | – | 110 | 12 |
| Horn mounting bolt | | | |
| 1996-2003 883 and 1200S models | – | 6-9 | 0.5-1 |
| Ignition coil mounting bolts | – | 24-72 | 3-8 |
| Ignition module mounting bolts 1986-1997 models | – | 15-21 | 1.5-2.5 |
| Ignition switch nut | | | |
| 1991-1994 models | – | 72 | 8 |
| Ignition switch retaining screw | | | |
| 1995-2003 models | – | 35-45 | 4-5 |
| Master cylinder clamp screws | | | |
| 1996-2003 models | – | 70-80 | 8-9 |
| Neutral indicator switch | – | 36-60 | 4-7 |
| Oil pressure switch | – | 60-84 | 7-9 |
| Rear brake light switch | – | 84-120 | 9-14 |
| Rotor bolt ¹ | – | 43-53 | 5-6 |
| Rotor-to-engine sprocket bolts ² | – | 90-110 | 10-12 |
| Speedometer sensor screw | – | 80-100 | 9-11 |
| Starter mounting bolts | 13-20 | – | 18-27 |
| Starter throughbolts | | | |
| 1986-1990 models | – | 20-25 | 2-3 |
| 1991-1994 models | | | |
| 883 models | – | 20-25 | 2-3 |
| 1200 models | – | 39-65 | 4-7 |
| 1995-2003 models | – | 39-65 | 4-7 |
| Stator Torx screws | – | 30-40 | 3-4.5 |
| Taillight base mounting screws | – | 45-48 | 5-5.5 |
| Taillight lens mounting screws | – | 20-24 | 2-3 |
| Timer screws | | | |
| Inner cover and sensor plate | – | 15-20 | 1.5-2 |
| Top center engine bracket | | | |
| Torx screw | – | 60-120 | 7-14 |
| Turn signal module screw | – | 36-60 | 4-7 |
| Vacuum operated electric switch | | | |
| 1986-1990 models | | | |
| Mounting bracket bolt | 20 | – | 27 |
| Ground wire bolt | 25-30 | – | 34-41 |
| 1991-1993 models | | | |
| Mounting bracket locknut | – | 60-144 | 7-16 |
| Ground wire bolt | 25-30 | – | 34-41 |
| 1994-2003 models | | | |
| Mounting bracket locknut | – | 60-144 | 7-16 |

1. Apply threadlock (Loctite 243 or equivalent).
2. Apply threadlock (Loctite 242 or equivalent).

CHAPTER THIRTEEN

WHEELS, TIRES AND SECONDARY DRIVE

This chapter covers the front and rear wheels, wheel hubs, tire service and the drive belt or drive chain. For routine maintenance, see Chapter Three.

Tables 1-13 are located at the end of this chapter.

MOTORCYCLE STANDS

Many procedures in this chapter require lifting the front or rear wheel off the ground. A motorcycle front end stand (**Figure 1**), swing arm stand or suitable size jack is required. Before purchasing or using a stand, check the manufacturer's instructions to make sure the stand will work with the specific model being worked on. If any adjustments or accessories are required, perform the necessary adjustments and install the correct parts before lifting the motorcycle. When using the stand, have an assistant standing by to help. Some means to tie down one end of the motorcycle may also be required. Make sure the motorcycle is properly supported on the stand.

If a motorcycle stand is not available, use a scissor jack (**Figure 2**) with adapters that fit onto the frame tubes (**Figure 3**, typical).

FRONT WHEEL

Removal

1. Support the motorcycle so the front wheel clears the ground.
2. Remove the brake caliper mounting bolts (**Figure 4**) and lift the caliper away from the brake disc. Support the caliper so it is not hanging from the brake line.
3. Place a spacer between the brake pads (**Figure 5**) in place of the disc. If the brake lever is inadvertently applied, the pistons will not be forced out of the caliper. If the pistons are forced out, disassemble the caliper and reseal the pistons as described in Chapter Sixteen.
4. Remove the axle nut (**Figure 6**), lockwasher and flat washer.
 - 5A. On 1986-1987 models, loosen the lower fork cap (**Figure 7**) nuts on both sides.
 - 5B. On 1988-2003 models, loosen the front axle pinch bolt nut (A, **Figure 8**). Do not remove the pinch bolt.
6. Tap the end of the axle (B, **Figure 8**) with a soft-faced mallet and remove it from the wheel. If the axle is tight, tap the end of the axle with a brass or aluminum drift.
7. Pull the wheel away from the fork sliders slightly.

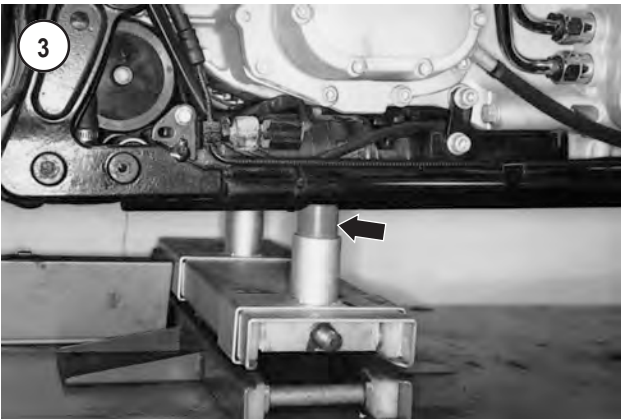
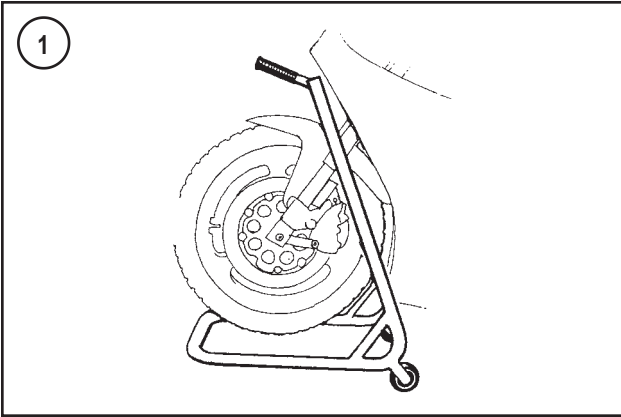

NOTE

Identify the wheel spacers during removal so they can be returned to their original positions.

- 8A. On 1986-1994 models, remove the speedometer drive gear and felt washer (**Figure 9**).
- 8B. On 1995-2003 models, remove the spacer.
9. Remove the right axle spacer (**Figure 10**), if necessary.

CAUTION

Do not set the wheel down on the brake disc surface, as it may be damaged.

10. Inspect the front wheel as described in this section.

Installation

1. Clean the axle in solvent and dry thoroughly. Make sure the axle bearing surfaces on both fork sliders and the axle are free from burrs and nicks.
2. Apply a light coat of wheel bearing grease to the axle shaft prior to installation.
3. Install the right axle spacer (**Figure 10**), if removed.
- 4A. On 1988-1994 models, install the felt seal (**Figure 9**) onto the speedometer drive and install the speedometer drive pin into the brake disc notch (**Figure 11**).
- 4B. On 1995-2003 models, install the spacer in the left side of the hub.
5. Hold the speedometer drive or the spacer in position and install the wheel between the fork sliders.
6. Insert the axle (B, **Figure 8**) through the front forks and wheel from the right side.
7. Install the flat washer, lockwasher and axle nut (**Figure 6**) finger-tight.
- 8A. On 1986-1987 models, tighten the lower fork cap nuts (**Figure 7**) on the left side to 132 in.-lb. (15 N•m). Insert a rod through the axle hole to hold the axle in place and tighten the axle nut (**Figure 6**) to 50 ft.-lb. (68 N•m). Tighten the lower fork cap nuts on the right side to 132 in.-lb. (15 N•m). Make sure the gaps between the cap and fork slider are equal front and rear. Remove the rod from the axle hole.
- 8B. On 1988-2003 models, insert a rod through the axle hole to hold the axle in place and tighten the axle nut (**Figure 6**) to 50-55 ft.-lb. (68-75 N•m). Tighten the front axle pinch bolt nut (A, **Figure 8**) to 21-27 ft.-lb. (28-37 N•m). Remove the rod from the axle hole.
9. Perform the *Front Wheel Bearing End Play Check* as described in this section.
10. Remove the spacer from the brake caliper pads. Then insert the brake disc spacer between the pads when installing the brake caliper. Do not damage the leading edge of the brake pads when installing the brake caliper. Tighten the brake caliper bolts (**Figure 4**) to 25-30 ft.-lb. (34-41 N•m).
11. After the wheel and brake are completely installed, rotate the wheel several times and apply the front brake a cou-



ple of times to make sure the wheel rotates freely and that the brake pads seat against the brake disc correctly.

Inspection

Replace worn or damaged parts as described in this section.

- 1A. On 1986-1999 models, these models are equipped with tapered roller bearings. Turn the bearing and check for roughness. If one bearing is damaged, replace both bearings as a set. Refer to *Front Hub* and *Rear Hub* in this chapter.

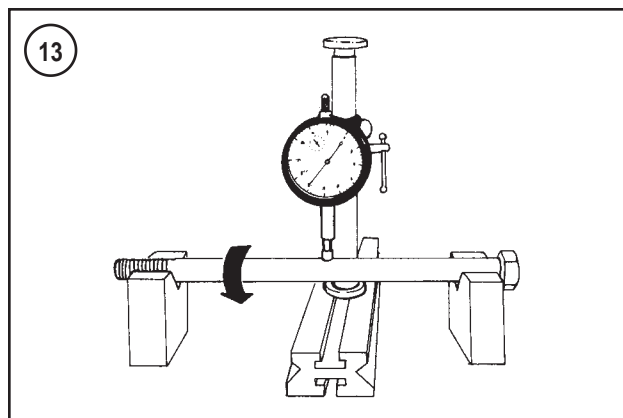
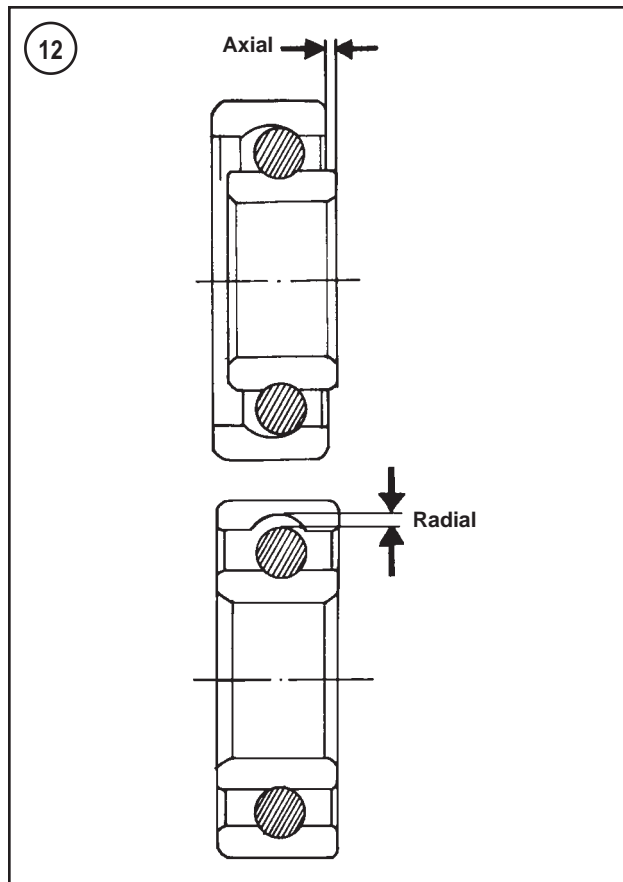

1B. On 2000-2003 models, these models are equipped with sealed ball bearings. Turn each bearing inner race by hand. The bearing should turn smoothly. Some axial play is normal, but radial play should be negligible. See **Figure 12**. If one bearing is damaged, replace both bearings as a set. Refer to the *Front Hub* and *Rear Hub* in this chapter.

2. Clean the axle and axle spacers in solvent to remove all grease and dirt. Make sure the axle contact surfaces are clean and free of dirt and old grease.

3. Check the axle runout with a set of V-blocks and a dial indicator (**Figure 13**).

4. Check the spacers for wear, burrs and damage.

5. Check the brake disc bolts for tightness. To service the brake disc, refer to Chapter Sixteen.

6. Check wheel runout and spoke tension, if applicable, as described in this chapter.

Front Wheel Bearing End Play Check

On 1986-early 1991 models, adjust end play by varying the length of the spacer sleeve between the wheel bearings. On late 1991-1999 models, adjust end play using spacer shims installed between the spacer sleeve and shoulder washer. End play is not adjustable on 2000-2003 models. See **Figure 14**, **Figure 15**, **Figure 16** or **Figure 17**. Excessive end play can cause bearing side loading and premature bearing failure. Wear in this area can be gauged by checking front wheel bearing end play each time the front wheel is removed. On 2000-2003 models, excessive end play indicates worn bearings.

After tightening the axle nut, check the front wheel bearing end play as follows.

NOTE

The front wheel must be installed on the motorcycle and off the ground when performing the following. Make sure the motorcycle is supported securely.

1. Tighten the front axle as described in this section.
2. Mount a dial indicator so that the plunger contacts the end of the axle (**Figure 18**). Then grasp the wheel and attempt to move the wheel back and forth by pushing and pulling it along the axle centerline. Measure axle end play by observing the dial indicator needle.
3. If the end play exceeds the specifications in **Table 1**, check front wheel installation. If the end play is incorrect, note the following:
 - a. On 1986-early 1991 models, replace the spacer sleeve with a longer or shorter one. See **Table 3** for spacer sleeve lengths.
 - b. On late 1991-1999 models, replace the spacer shim with a thicker or thinner one. See **Table 4** for spacer shim thicknesses.
 - c. On 2000-2003 models, replace the wheel bearings if end play is excessive.
 - d. On all models, remove the wheel and service the front hub as described in *Front Hub* in this chapter.
 - e. Install the front wheel as described in this section.
 - f. Recheck the bearing end play measurement.

FRONT HUB (1986-1999 MODELS)

Tapered roller bearings are installed on each side of the hub. Seals are installed on the outside of each bearing to protect them from dirt and other contaminants. The bearings can be removed from the hub after removing the outer

14

LACED FRONT WHEEL (1986-1999 MODELS)

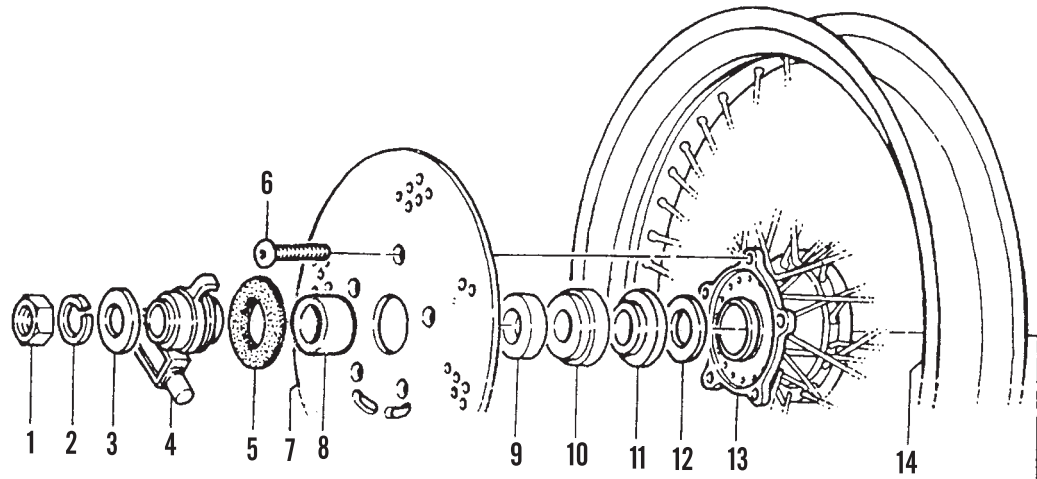

- | | |
|--|--|
| 1. Axle nut | 9. Seal |
| 2. Lockwasher | 10. Bearing |
| 3. Washer | 11. Shoulder washer (late 1991-1999 models) |
| 4. Speedometer drive (1986-1994 models) | 12. Shim pack (late 1991-1999 models) |
| 5. Felt seal (1986-1994 models) | 13. Hub |
| 6. Bolt | 14. Rim |
| 7. Brake disc | 15. Hub spacer |
| 8. Spacer (1995-1999 models) | 16. Axle |

15

CAST FRONT WHEEL (1986-1999 MODELS)

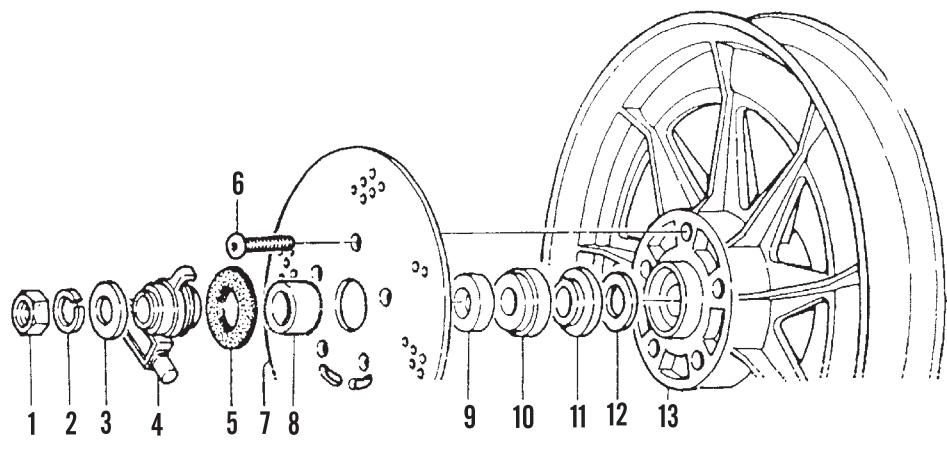

- | | |
|--|--|
| 1. Axle nut | 9. Seal |
| 2. Lockwasher | 10. Bearing |
| 3. Washer | 11. Shoulder washer (late 1991-1999 models) |
| 4. Speedometer drive (1986-1994 models) | 12. Shim pack (late 1991-1999 models) |
| 5. Felt seal (1986-1994 models) | 13. Wheel |
| 6. Bolt | 14. Hub plate |
| 7. Brake disc | 15. Spacer |
| 8. Spacer (1995-1999 models) | 16. Axle |

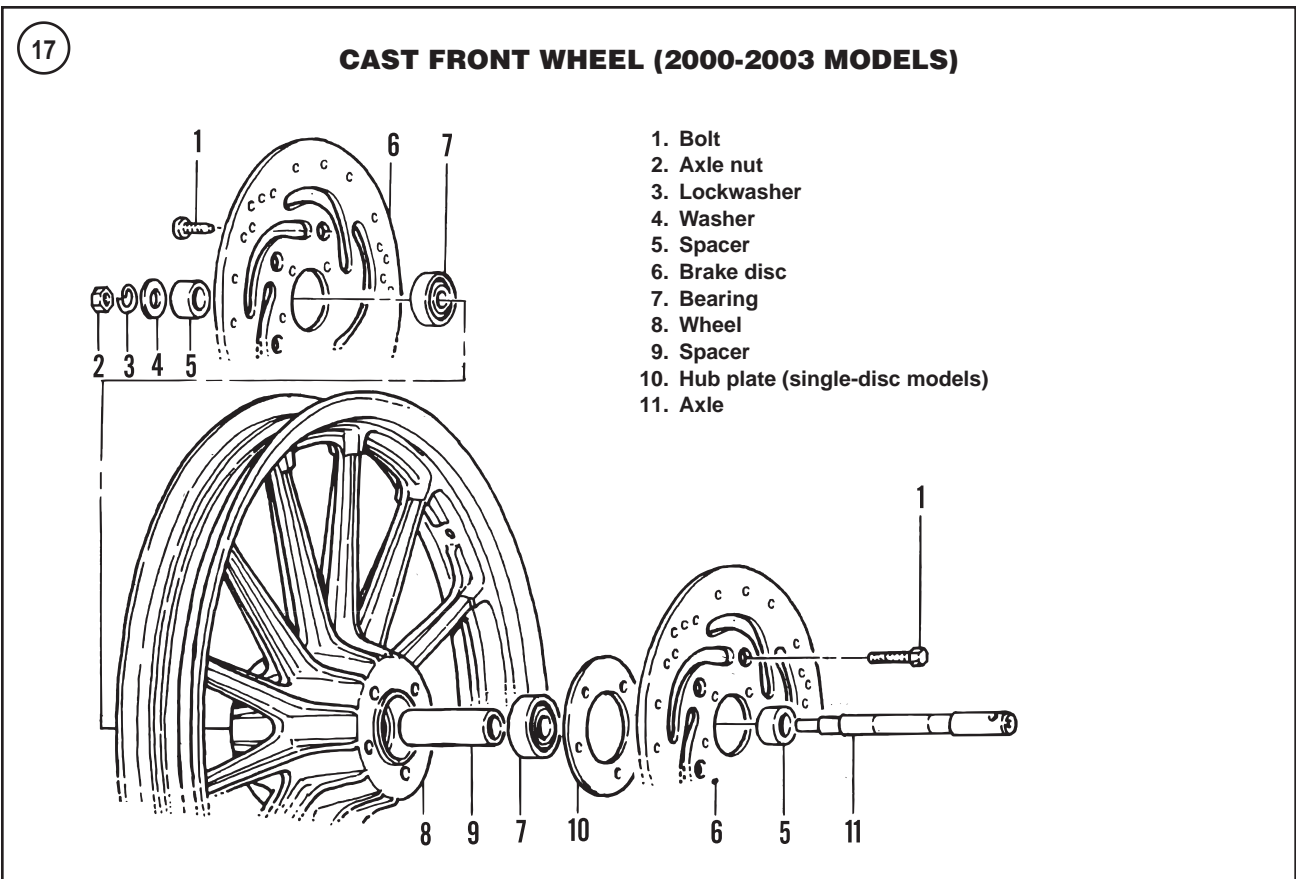
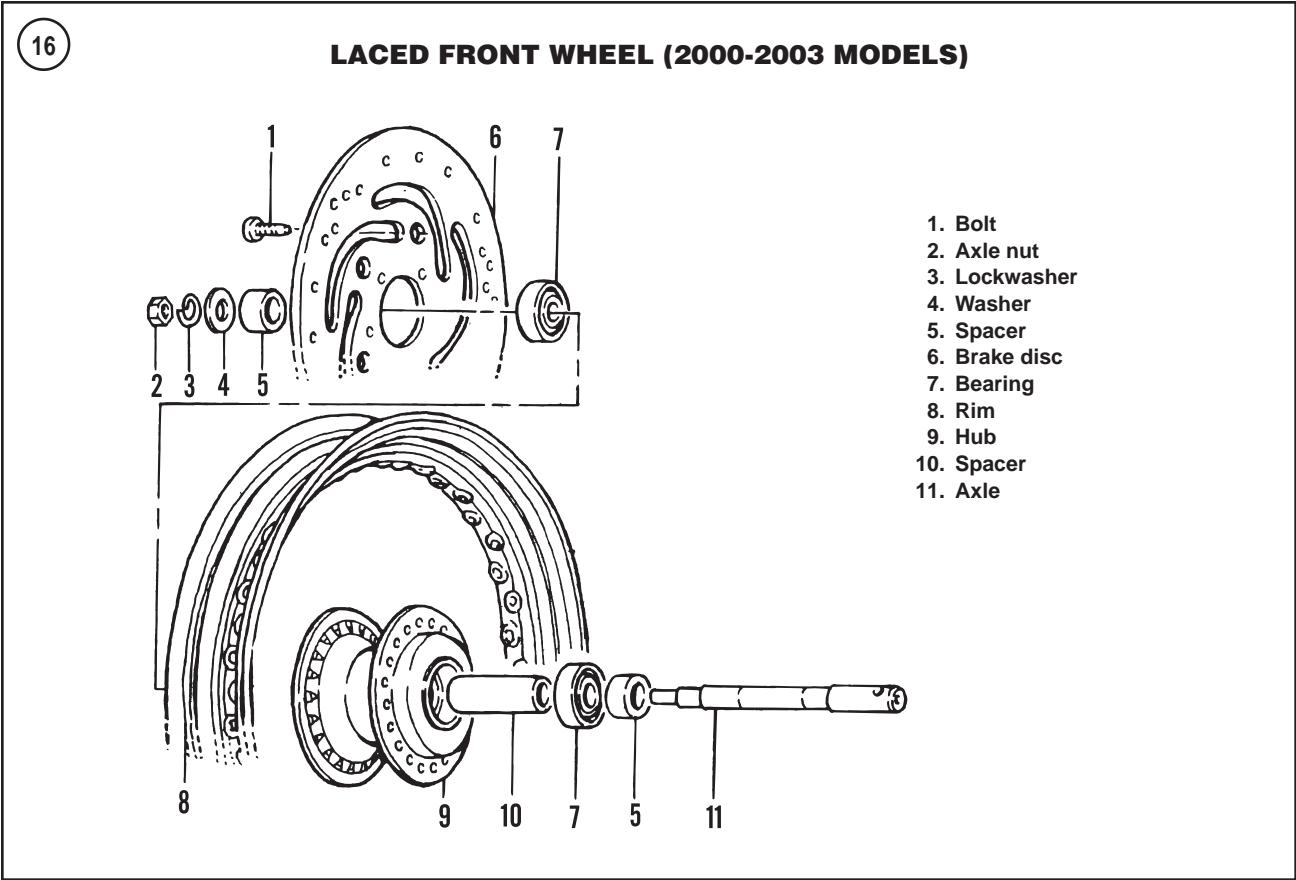

seals. The bearing races are pressed into the hub and should not be removed unless they require replacement.

Disassembly/Inspection/Reassembly

Refer to **Figure 14** or **Figure 15**.

NOTE

The bearings and races are matched pairs. Label all parts so they may be returned to their original positions.

1. Remove the front wheel as described in this chapter.
2. If necessary, remove the brake disc as described in Chapter Sixteen.
3. If necessary, remove the hub plates on cast wheel.
4. Pry the oil seals out of the hub. If using a screwdriver, place a rag underneath the screwdriver (**Figure 19**) to avoid damaging the hub.
5. Remove the bearing assemblies (**Figure 20**) and spacer sleeve. On late 1991-1999 models, remove the shoulder washer and spacer shim(s).
6. Wash the bearings thoroughly in solvent and dry with compressed air. Wipe the bearing races off with a clean rag dipped in solvent. Then check the roller bearings and races for wear, pitting or excessive heat (bluish tint). Replace the bearing and races as a complete set. Replace the bearing races as described in Step 7. If the bearing and its race do not require replacement, proceed to Step 8. If reinstalling the original bearing(s), pack the bearing thoroughly with grease and wrap it in a clean, lint-free cloth or wax paper. Wipe a film of grease across the bearing race.

CAUTION

If the proper size tool to drive the race into the hub is not available, have a dealership install the race. Do not attempt to install the race by driving it into the hub with a small diameter punch or rod.

7. Replace the bearing races (**Figure 21**, typical) as follows:
 - a. A universal bearing remover should be used to remove the races from the hub. If this tool is unavailable, insert a drift punch through the hub and tap the race out of the hub with a hammer. Move the punch around the race to make sure the race is driven squarely out of the hub. Do not allow the race to bind in the hub as this can damage the race bore in the hub. Severe damage to the race bore will require replacement of the hub.
 - b. Clean the inside and outside of the hub with solvent. Dry with compressed air.
 - c. Wipe the outside of the new race with oil and align it with the hub. Using a bearing driver or socket with an outside diameter slightly smaller than the bearing race, drive the race into the hub until it bottoms on the hub shoulder. Be sure the race is square with the hub

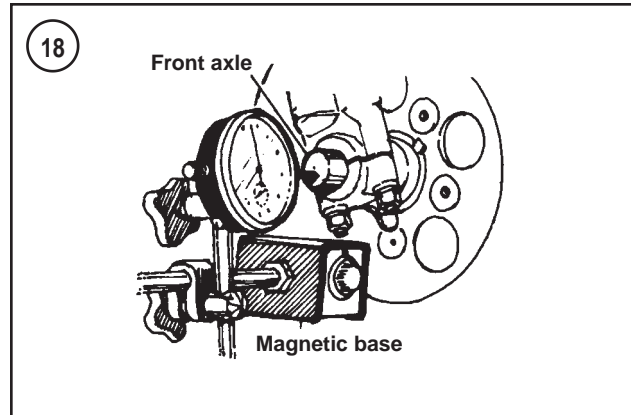

bore. Do not allow the race to bind during installation.

8. Make sure the hub is clean prior to installing the bearings.
9. Lubricate the ends of the spacer sleeve with grease and install it into the hub.
10. On late 1991-1999 models, perform the following:
 - a. Install the spacer shim(s) into the left side of the hub and rest it against the hub counterbore.
 - b. Install the shoulder washer into the hub, with its shoulder side facing out, and seat it against the spacer shim(s).
11. Lubricate each bearing race with grease.



12. Pack the bearings with grease and install them in the bearing races.

13. Pack the seal lip cavity of each new seal with grease.

14. The seals are identical and can be installed on either side.

15. Install the seals using a bearing driver or socket with an outer diameter slightly smaller than the seal (**Figure 22**). Drive the oil seals into the hub until they are flush with the hub or recessed 0.020 in. (0.51 mm) below the hub surface.

16. If the brake disc was removed, install it as described in Chapter Sixteen.

17. If the hub plate was removed on cast wheels, install the hub and secure it with new Torx screws. Tighten the hub plate Torx screws to 16-24 ft.-lb. (22-33 N•m).

18. After the wheel is installed on the motorcycle and the front axle tightened to specification, check the bearing end play as described in this chapter.

19. If the hub on spoke wheels is damaged, the hub can be replaced by removing the spokes and assembling a new hub. If the hub on cast wheels is damaged, the wheel assembly must be replaced; it cannot be repaired.

FRONT HUB (2000-2003 MODELS)

Sealed ball bearings are installed on each side of the hub. Do not remove the bearing assemblies unless they require replacement.

Disassembly/Inspection/Reassembly

Refer to **Figure 16** or **Figure 17**.

CAUTION

Do not remove the wheel bearings for inspection as they will be damaged during the removal process. Remove wheel bearings only if replacement is required.

1. Remove the front wheel as described in this chapter.
2. Remove the axle spacers from each side of the hub if they are still in place.

CAUTION

Make sure the brake disc(s) will not be damaged while performing the following procedure. If damage may occur, remove the brake disc(s) as described in Chapter Sixteen.

3. If necessary, remove the bolts securing the brake disc(s) (**Figure 23**) and remove the disc(s).
4. Inspect the wheel bearings. If they must be replaced, proceed as follows.

WARNING

Make sure to wear eye protection when removing the bearings.

5A. If not using a wheel bearing remover, perform the following:

- a. To remove the right and left bearings and spacer sleeve, insert a soft aluminum or brass drift into one side of the hub.
- b. Push the spacer to one side and place the drift on the inner race of the lower bearing.
- c. Tap the bearing out of the hub with a hammer, working around the perimeter of the inner race (**Figure 24**). Remove the bearing and spacer.
- d. Repeat substeps b and c for the bearing on the other side.

5B. To remove the bearings with a bearing remover, perform the following:

- a. Select the correct size remover head tool and insert it into the bearing.
 - b. Turn the wheel over and insert the remover shaft into the backside of the adapter. Tap the wedge and force it into the slit in the adapter. This forces the adapter against the bearing inner race. Refer to **Figure 25**.
 - c. Tap the end of the wedge bar with a hammer to drive the bearing out of the hub. Remove the bearing and the spacer.
 - d. Repeat substeps a-c for the bearing on the other side.
6. Clean the inside and the outside of the hub with solvent. Dry it with compressed air.

Assembly

CAUTION

The removal process damages the bearings. Replace the wheel bearings in pairs. Never reinstall bearings after they are removed. Always install new bearings.

1. Thoroughly clean the hub prior to installing the new bearings.
2. Apply a light coat of wheel bearing grease to the bearing seating areas of the hub. This makes bearing installation easier.

CAUTION

Install non-sealed bearings with the single sealed side facing out. Tap the bearings squarely into place and tap on the outer race only. Do not tap on the inner race or the bearing will be damaged. Make sure the bearings are completely seated.

3. Select a driver, or socket (**Figure 26**), with an outside diameter slightly smaller than the bearing's outside diameter.
4. Tap on the outer race of the bearing until the bearing bottoms in the hub bore. Be sure the bearing is square in the bore.
5. Turn the wheel over and install the spacer.
6. Use the same tool set-up to drive in the remaining bearing.
7. If removed, install the removed brake disc(s) as described in Chapter Sixteen.
8. Install the front wheel as described in this chapter.

REAR WHEEL

All models may be equipped with a laced or spoked cast rear wheel. Models after 1999 may also be equipped with a disc cast rear wheel. Service information for cast wheels applies to both spoked and disc type wheels.

Removal

1. Support the motorcycle so the rear wheel is off the ground.

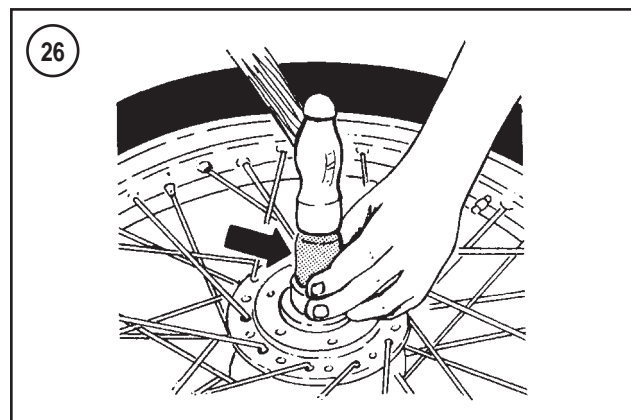
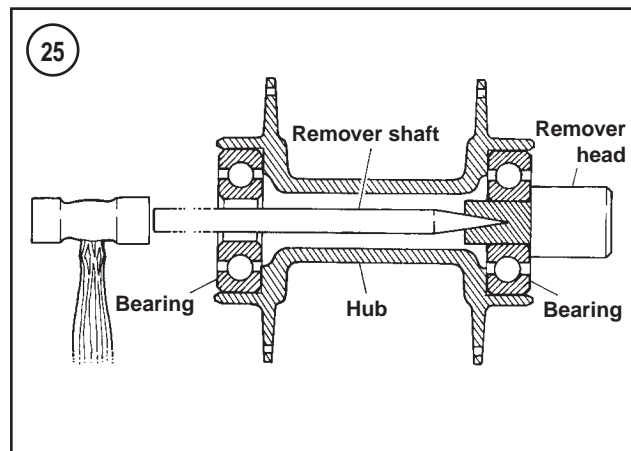
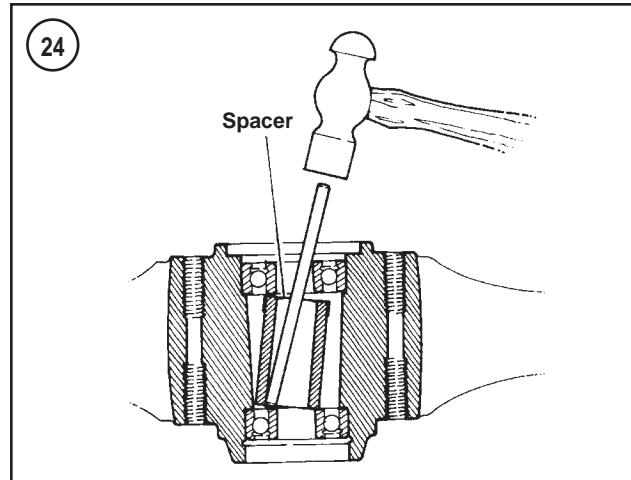

NOTE

The rear wheel is heavy and can be difficult to remove. Check the tire-to-ground clearance before removing the rear axle. If necessary, have an assistant help in the removal or place wooden blocks under the wheel.

2. Remove and discard the rear axle cotter pin (A, **Figure 27**).
3. Loosen the drive chain or belt adjusting locknuts and adjuster bolts (B, **Figure 27**).
4. Loosen and remove the axle nut (C, **Figure 27**) and washer.



5. Slide the axle out of the wheel (**Figure 28**) and allow the wheel to drop to the ground.

NOTE

Identify the wheel spacers during removal so they can be returned to their original positions.

6. Remove the outer right axle spacer (**Figure 29**).

CAUTION

Do not set the wheel down on the brake disc surface, as it may be damaged.

NOTE

On 1986-1999 models, the shoulders on the inner left and right axle spacers are inserted through the seal. These spacers should not fall out when the wheel is removed.

7. Lift the drive chain or belt off the sprocket and remove the rear wheel (**Figure 30**).

8. Place a spacer between the brake pads in place of the disc. With the spacer in place, if the brake lever is inadvertently applied, the pistons will not be forced out of the caliper. If the pistons are forced out, disassemble the caliper to reseat the pistons as described in Chapter Sixteen.

9. Inspect the rear wheel assembly as described in this chapter.

Installation

1. Clean the axle in solvent and dry thoroughly. Make sure the axle bearing surfaces on the axle are free from burrs and nicks.

2. Apply a film of waterproof bearing grease to the axle shaft prior to installation.

3. On 1986-1999 models, make sure the inner left and right axle spacers are inserted through the seal as shown in **Figure 31**. If necessary, install the spacers and oil seals as described in *Rear Hub* in this chapter

4. Remove the spacer from between the brake caliper. Then position the rear wheel into the swing arm, through the drive chain or belt, and position the right axle spacer (**Figure 29**) between the swing arm and wheel.

5. Lift the wheel into position and install the axle (**Figure 28**) from the right side.

6. Install the washer (C, **Figure 27**) and nut.
7. Adjust the drive chain or belt as described in Chapter Three.

CAUTION

If it is necessary to tighten the axle nut to align the axle nut slot with the cotter pin hole in the axle, do not exceed the maximum torque specification.

8. Tighten the axle nut to 60-65 ft.-lb. (81-88 N•m).
9. Perform the *Rear Wheel Bearing End Play Check* in this section.
10. Install a new cotter pin (A, **Figure 27**).
11. Rotate the wheel several times to make sure it rotates freely and that the brakes work properly.

Inspection

Replace worn or damaged parts as described in this section.

1A. 1986-1999 models are equipped with tapered roller bearings. Turn the bearing and check for roughness. If one bearing is damaged, replace both bearings as a set. Refer to *Rear Hub* in this chapter.

1B. 2000-2003 models are equipped with sealed ball bearings. Turn each bearing inner race by hand. The bearing should turn smoothly. Some axial play is normal, but radial play should be negligible. See **Figure 32**. If one bearing is damaged, replace both bearings as a set. Refer to *Rear Hub* in this chapter.

2. Clean the axle and axle spacers in solvent. Make sure the axle contact surfaces are clean.
3. Check the axle runout with a set of V-blocks and a dial indicator (**Figure 33**). The manufacturer does not provide a runout specification. Replace the axle if it is not straight.
4. Check the spacers for wear, burrs and damage. Replace as necessary.
5. Check the brake disc bolts for tightness. To service the brake disc, refer to Chapter Sixteen.
6. Check wheel runout and spoke tension, if applicable, as described in this chapter.

Rear Wheel Bearing End Play Check

To check rear wheel bearing end play, follow the procedure described in the *Front Wheel Bearing End Play Check* in *Front Wheel* in this chapter. Note the following:

1. Tighten the axle nut to 60-65 ft.-lb. (81-88 N•m).
2. If necessary, remove the wheel and disassemble the rear hub as described in *Rear Hub* in this chapter.

REAR HUB (1986-1999 MODELS)

Tapered roller bearings are installed on each side of the hub. Seals installed on the outside of each bearing protect

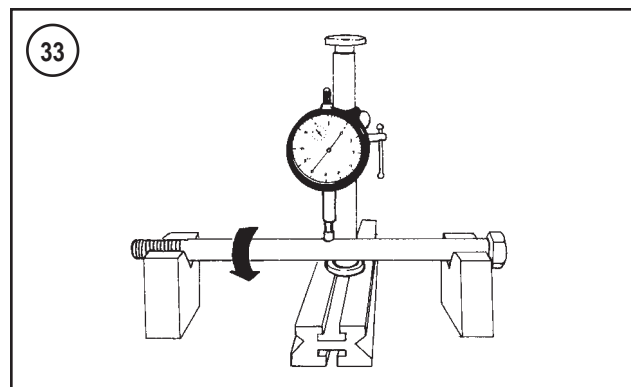
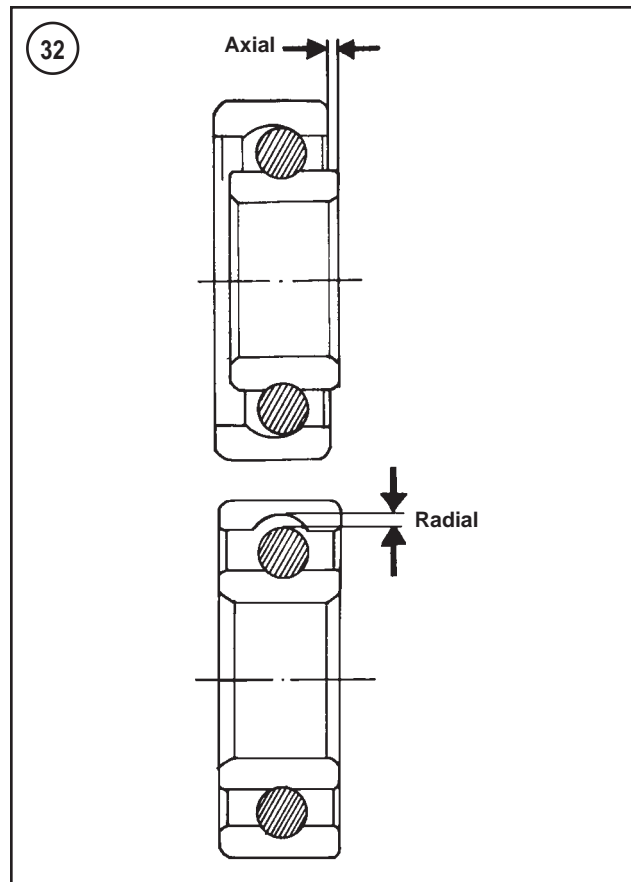

them from dirt and other contaminants. The bearings can be removed from the hub after removing the outer seals. The bearing races are pressed into the hub and should not be removed unless they require replacement.

Disassembly/Inspection/Reassembly

Refer to **Figure 34** or **Figure 35**.

NOTE

The bearings and races are matched pairs. Label all parts so that they may be returned to their original positions.

1. Remove the rear wheel as described in this chapter.

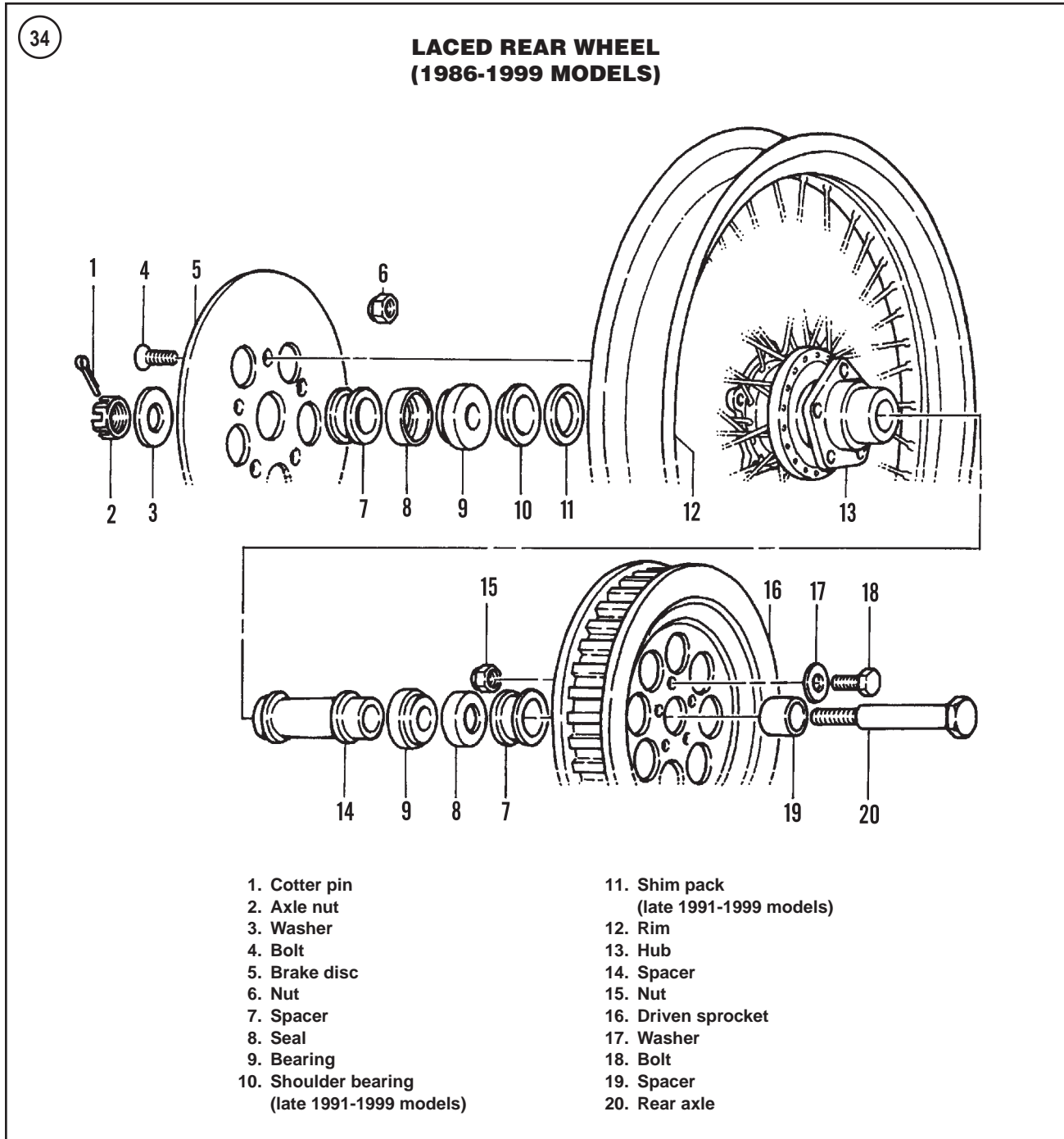

2. If necessary, remove the brake disc as described in Chapter Sixteen.

3. If necessary, remove the driven sprocket as described in this chapter.

4. Remove the inner spacers (**Figure 36**).

5. Pry the oil seals out of the hub (**Figure 37**). If using a screwdriver, place a rag underneath the screwdriver to avoid damaging the hub. Remove the spacer from the oil seal, if so equipped. Then identify and remove the bearing from its race.

6. On late 1991-1999 models, remove the spacer shim(s) and shoulder washer.

7. Remove the spacer sleeve from the hub and wash it thoroughly in solvent.

8. Repeat to remove the opposite bearing. Label the bearings if they are going to be reused.

9. Wash the bearings thoroughly in solvent and dry with compressed air. Wipe the bearing races off with a clean rag dipped in solvent. Then check the roller bearings and races for wear, pitting or excessive heat (bluish tint). Replace the bearing and races as a complete set. Replace the bearing races as described in Step 10. If the bearing and its race do not require replacement, proceed to Step 11. If reinstalling the original bearing(s), pack the bearing thoroughly with

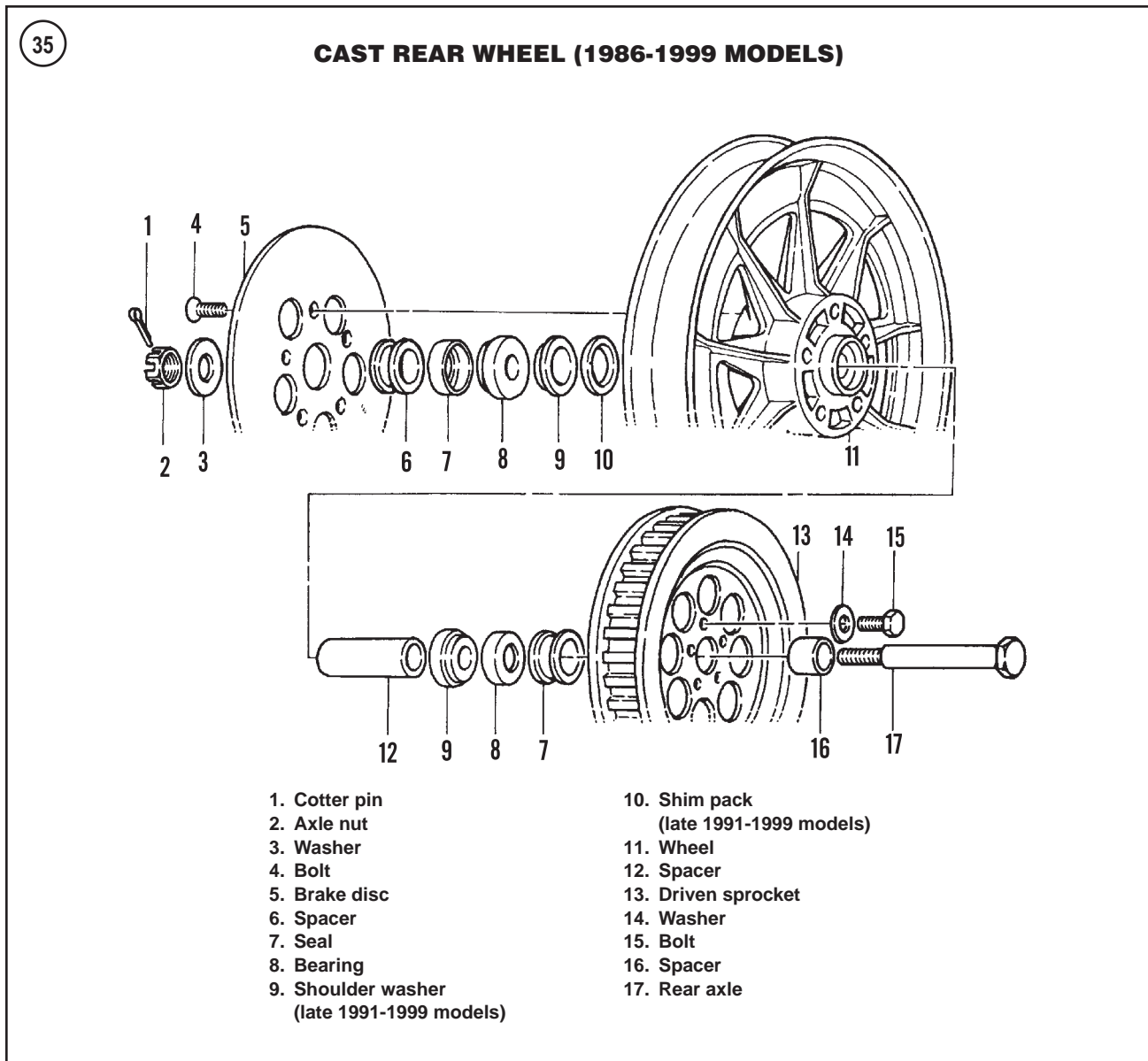

grease and wrap it in a clean, lint-free cloth or wax paper. Wipe a film of grease across the bearing race.

CAUTION

If you do not have the proper size tool to drive the race into the hub, have a dealership install the race. Do not attempt to install the race by driving it into the hub with a small diameter punch or rod.

10. Replace the bearing races (Figure 21) as follows:

- a. A universal bearing remover should be used to remove the races from the hub. If this tool is unavailable, insert a drift punch through the hub and tap the race out of the hub with a hammer. Move the punch around the race to make sure the race is driven squarely out of the hub. Do not allow the race to bind in the hub as this can damage the race bore in the hub.

Severe damage to the race bore will require replacement of the hub.

- b. Clean the inside and outside of the hub with solvent. Dry with compressed air. Lubricate the outside of the new race with oil and align it with the hub. Using a bearing driver or socket with an outside diameter slightly smaller than the bearing race, drive the race into the hub until it bottoms on the hub shoulder. Make sure the race is square with the hub bore. Do not allow the race to bind during installation.
11. Clean the hub prior to installing the bearings.
 12. Lubricate the ends of the spacer sleeve with grease and install it into the hub.
 13. On late 1991-1999 models, perform the following:
 - a. Install the spacer shim(s) into the left side of the hub and rest it against the hub counterbore.



- b. Install the shoulder washer into the hub, with the shoulder side facing out, and seat it against the spacer shim(s).
14. Lubricate each bearing race with grease.
15. Pack the bearings with grease and install them in the bearing races.
16. Install new seals as follows:
 - a. Pack the seal lip cavity of each seal with grease.
 - b. The seals can be installed into either side.
 - c. Install the seals so the closed side faces out.
 - d. Use a bearing driver or socket with an outer diameter slightly smaller than the seal (**Figure 35**) to install the seals.
 - e. On laced wheels, install the seals so the outer surface is 0.26-0.28 in. (6.6-7.1 mm) below the hub surface.
 - f. On cast wheels, install the oil seals so the outer surface is 0.31 in. (7.9 mm) below the hub surface.
17. If the brake disc was removed, refer to Chapter Sixteen for correct procedures and torque specification.
18. If the driven sprocket was removed, install it as described in this chapter.
19. After the wheel is installed on the motorcycle and the rear axle tightened to the specified torque specification, check the bearing end play as described in this chapter.
20. If the hub on spoke wheels is damaged, the hub can be replaced by removing the spokes and assembling a new hub. If the hub on cast wheels is damaged, replace the wheel assembly; it cannot be repaired.

REAR HUB (2000-2003 MODELS)

Sealed bearings are installed on each side of the hub. Do not remove the bearing assemblies unless they require replacement.

Disassembly/Inspection/Reassembly

Refer to **Figure 38** or **Figure 39**. Follow the procedure described in the *Front Hub* section for 2000-2003 models.

DRIVE CHAIN AND SPROCKETS

A drive chain (**Figure 40**) was originally installed on all 1986-1990 models and 1991-1992 Standard and Hugger models. O-ring type drive chains were installed on 1992 models.

Refer to Chapter Three for drive chain inspection, cleaning and adjustment procedures.

Drive Chain Size

The standard drive chain size is No. 530 (3/8 in. wide)×110 links.

Drive Chain Removal/Installation

A chain breaker is required to remove the master link.

1. Support the motorcycle so the rear wheel is off the ground.

NOTE

If reusing the drive chain, mark the chain's installation position (side and top positions). That way, the chain can be installed in the same position.

2. Turn the rear wheel and drive chain until the master link is accessible.
3. Remove the master link spring clip with a pair of pliers.
4. Using a chain breaker, press the connecting link out of the side plate. When disconnecting an O-ring chain, remove the four O-rings (**Figure 41**, typical).

NOTE

If reusing the existing drive chain rather than installing a new chain, substitute another drive chain so it can temporarily replace the existing drive chain.

5. To install the new drive chain, connect it to the original chain with the old master link. Pull the new chain around the front sprocket.
6. Disconnect the original chain from the new chain.

38

LACED REAR WHEEL (2000-2003 MODELS)

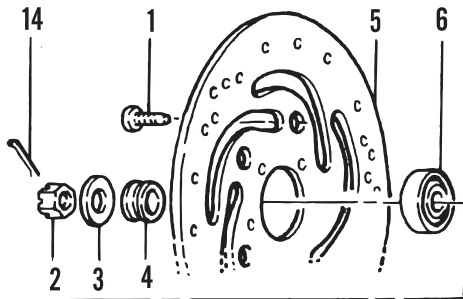

- | | |
|---------------|---------------------|
| 1. Bolt | 8. Hub |
| 2. Axle nut | 9. Spacer |
| 3. Washer | 10. Driven sprocket |
| 4. Spacer | 11. Spacer |
| 5. Brake disc | 12. Axle |
| 6. Bearing | 13. Washer |
| 7. Rim | 14. Cotter pin |

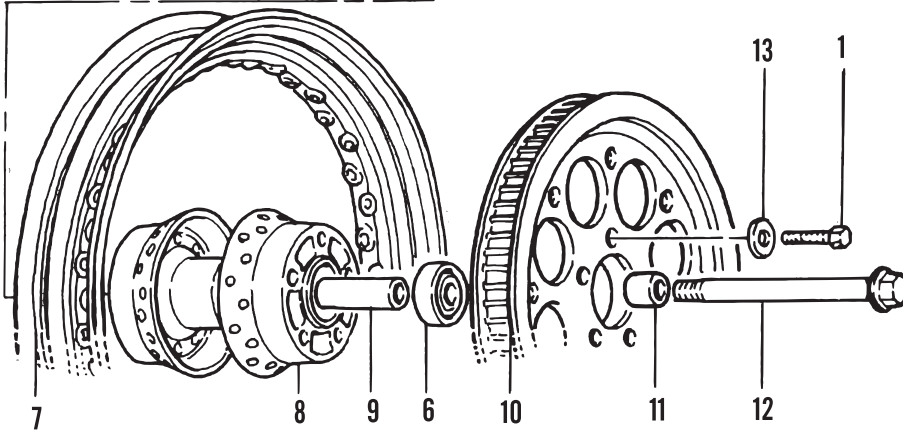

39

CAST REAR WHEELS (2000-2003 MODELS)

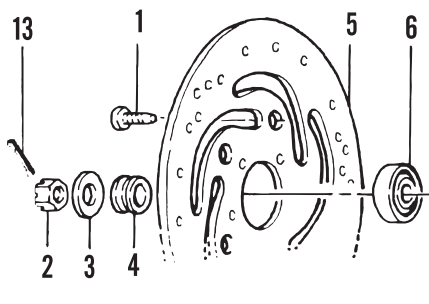

- | | |
|---------------|--------------------|
| 1. Bolt | 8. Spacer |
| 2. Axle nut | 9. Driven sprocket |
| 3. Washer | 10. Spacer |
| 4. Spacer | 11. Axle |
| 5. Brake disc | 12. Washer |
| 6. Bearing | 13. Cotter pin |
| 7. Wheel | |

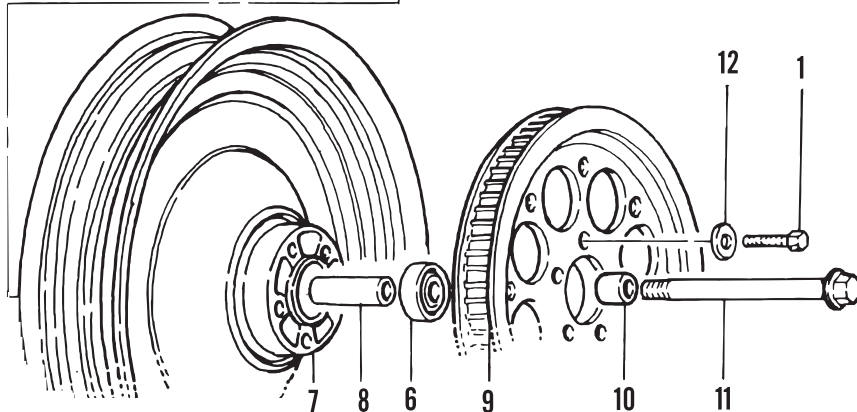

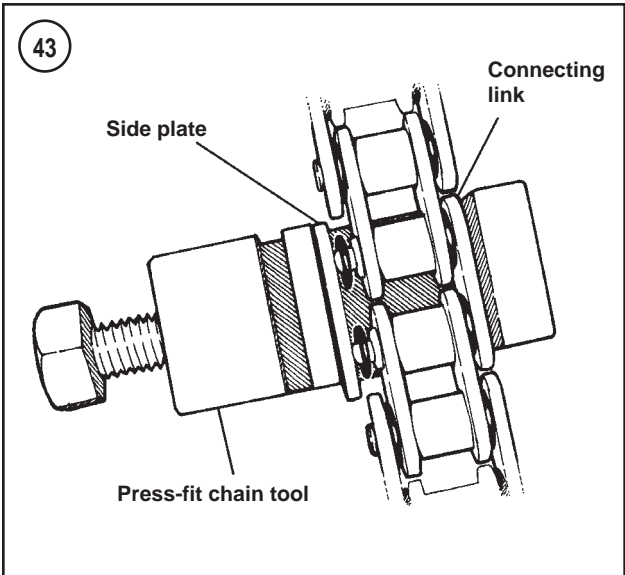
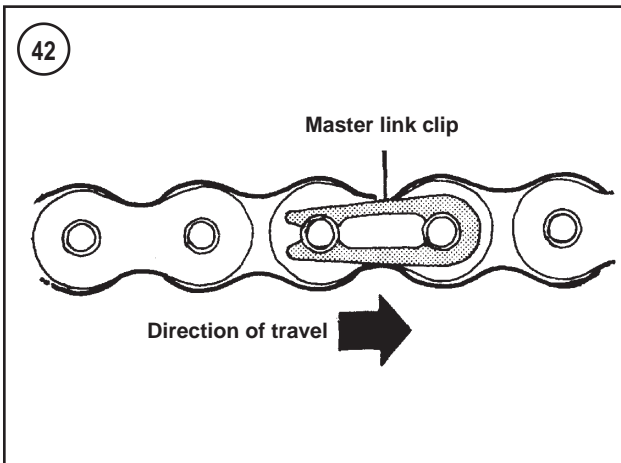
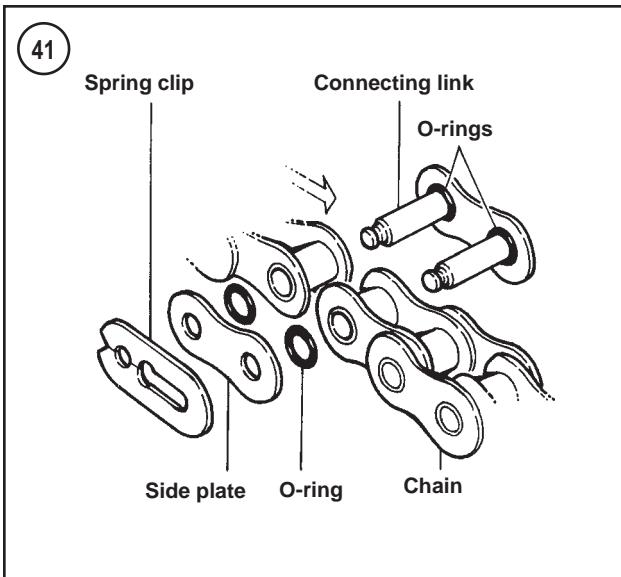

- b. If assembling the chain using a press fit master link, refer to *Press Fit Master Link* in this section to press the side plate onto the connecting link.
- c. Install the spring clip onto the master link so the closed end of the clip faces the direction of chain travel (Figure 42).
- d. Lubricate and adjust the drive chain as described in Chapter Three.

Press Fit Master Link

CAUTION

Attempting to install a press-fit master link without the proper tools can damage the master link and parts of the chain.

NOTE

Most commercial press-fit chain tools are designed to press the side plate onto the connecting link to its correct depth. If the side plate is pressed on too far, it will bind the chain where it is joined at the master link. If the side plate is not pressed on far enough, the spring clip cannot be installed correctly and will probably come off. Properly installed, the side plate is flush with both pin seating grooves in the connecting link.

- 7. If reusing the original chain, service it as required, then connect it to the old chain and pull it around the front sprocket. Disconnect the chains.
- 8. Install by reversing the preceding removal steps while noting the following:
 - a. On an O-ring chain, install the four O-rings onto the master link as shown in Figure 41, typical.

Many drive chains are equipped with a master link side plate that is pressed into place. To install this type of master link, a press-fit chain tool is required; Figure 43 illustrates one type of chain press tool. To disconnect the chain, first remove the outer clip from the master link, then use a chain breaker to separate the side plate from the connecting link.

Cutting a Drive Chain to Length

The standard drive chain size is No. 530 (3/8 in. wide)×110 links. If the replacement drive chain is too long, cut it to length as follows.

1. Stretch out the new chain on a workbench without the master link.
2. Count out 110 links on the new chain. Mark the two chain pins to indicate the cutting position. Recount the chain links to verify that the cutting mark is accurate.

WARNING

Wear safety glasses when using a grinder.

3. Grind the head of two pins flush with the face of the side plate.
4. Support the chain, then use a chain breaker or a punch and hammer and tap the pins out of the side plate. If the pins remain tight, grind more material from the end of the pins and then try again.
5. Remove the side plate and push out the connecting link.

Service and Inspection

Refer to Chapter Three.

Drive Sprocket Removal/Installation

The drive sprocket (front) is mounted on the end of mainshaft fifth gear.

1. Remove the exhaust pipes as described in Chapter Ten or Chapter Eleven.
2. Remove the rear master cylinder bolts (A, **Figure 44**) and remove the footpeg and brake pedal assembly (B). It is not necessary to disconnect the brake line from the master cylinder.
3. Remove the master cylinder hose clip (A, **Figure 45**).
4. Remove the sprocket cover (B, **Figure 45**).
5. Remove the drive sprocket lockscrew (**Figure 46**).
6. Loosen the rear axle nut (A, **Figure 47**) and loosen the chain adjusters (B).

NOTE

The drive sprocket nut on 1991-1992 models has left-hand threads.

7. Turn the drive sprocket nut (**Figure 48**) clockwise and remove it.
8. Remove the drive sprocket from the transmission mainshaft.
9. Installation is the reverse of the removal steps while noting the following.
 - a. Remove all thread locking compound from the sprocket nut and mainshaft threads.
 - b. Install the drive sprocket (**Figure 48**) onto the mainshaft.

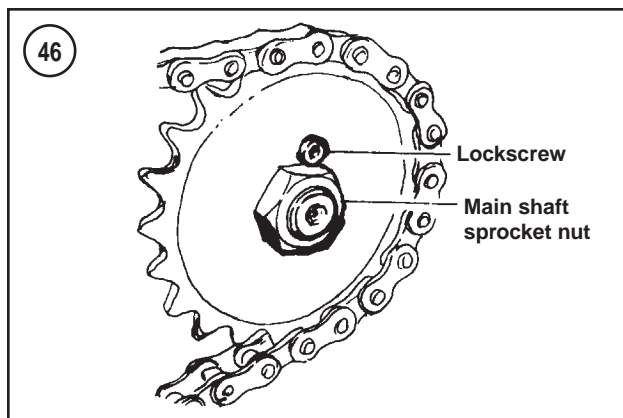
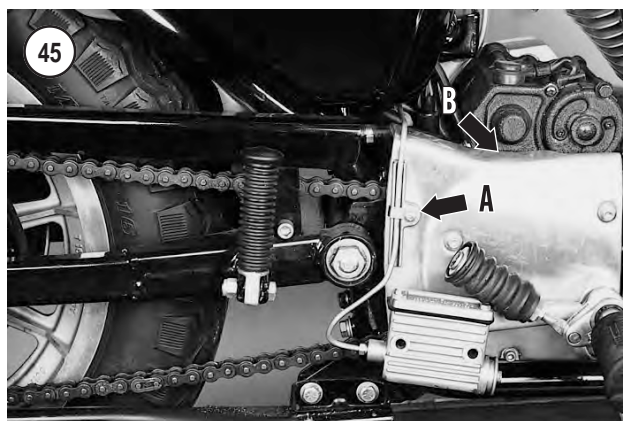

- c. Apply threadlock (Loctite 262 or equivalent) to the sprocket nut threads and thread the nut onto the mainshaft by turning it counterclockwise. Tighten the nut to the torque specification in **Table 13**.
- d. Determine which one of the three drive sprocket lockscrew holes aligns with a nut flat; see **Figure 46**. If none of the holes align with a nut flat, tighten the nut until one of the lockscrew holes aligns with a nut at flat.

CAUTION

If the drive sprocket nut requires additional tightening, do not exceed 90 ft.-lb. (N•m) on 1986-1990 models or 150 ft.-lb. (203 N•m) on

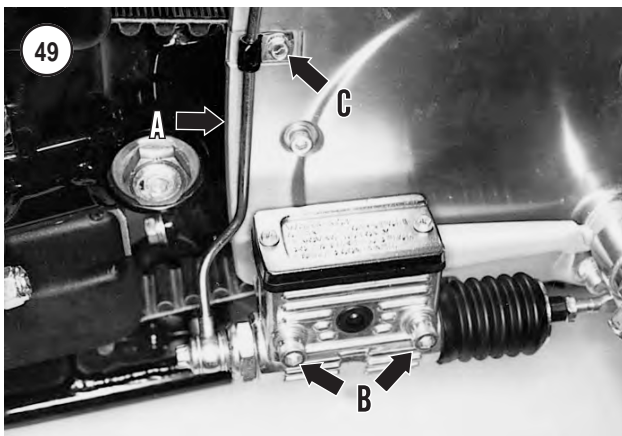
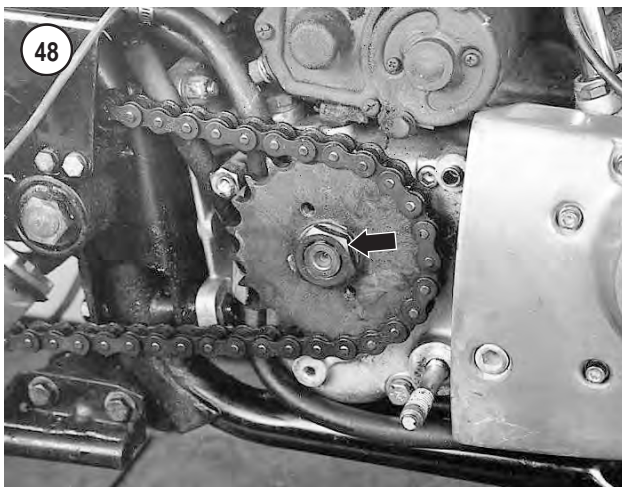

1991-1992 models. Do not loosen the drive sprocket nut to align the screw hole.

- e. Apply Loctite 242 (blue) to the drive sprocket lockscrew threads. Then install the lockscrew into the correct sprocket hole so that it rests against the nut flat (Figure 46) and tighten to 50-60 in.-lb. (6-7 N•m).
- f. Reverse Steps 1-3 to complete assembly. Tighten the drive sprocket cover screws to 90-110 in.-lb. (10-12

N•m) and rear master cylinder screws to 155-190 in.-lb. (18-21 N•m).

WARNING

Check that the rear brake is operating properly before riding the motorcycle.

- g. If the rear master cylinder pushrod locknut was loosened, adjust the rear brake as described in Chapter Three.
- h. Adjust the drive chain (Chapter Three).

Driven Sprocket Removal/Installation

The driven sprocket (rear) is bolted to the rear wheel (Figure 47).

1. Remove the rear wheel as described in this chapter.
2. Remove the bolts and nuts securing the sprocket to the hub and remove the sprocket.
3. Replace worn or damaged sprocket fasteners as required.
4. Installation is the reverse of the preceding steps. Tighten the sprocket nuts and bolts to the torque listed in Table 13.

Sprocket Inspection

Inspect the sprocket teeth. If the teeth are visibly worn, replace both the drive and driven sprockets and the drive chain. Never replace any one sprocket or chain as a separate item; worn parts will cause rapid wear of the new component. Refer to *Drive Chain Adjustment* in Chapter Three for additional information.

DRIVE BELT AND SPROCKETS

Drive belt assemblies are installed on all 1991-1992 883 Deluxe models, 1991-1992 1200 models and all 1993-2003 models. Drive belts can be identified by number of teeth and color code; see Table 1 in Chapter Nine.

Drive Belt Removal/Installation

1. Remove the rear wheel as described in this chapter.
2. Remove the rear sprocket cover (A, Figure 49) as follows:

NOTE

It is not necessary to disconnect the brake line at the master cylinder.

- a. Loosen then remove the rear brake master cylinder mounting bolts (B, Figure 49) and washers.
- b. On all models except 1999-2003 883C and 1200C, remove the clevis pin cotter pin at the rear brake pedal. Then remove the clevis pin (Figure 50) to disconnect the brake pedal from the brake rod end.

- c. On 1999-2003 883C and 1200C models, remove the rear brake pedal assembly as described in Chapter Sixteen.
 - d. Remove the screw and clip (C, **Figure 49**) securing the brake line to the sprocket cover.
 - e. Loosen then remove the Allen bolts and washers securing the sprocket cover to the engine. Remove the sprocket cover (A, **Figure 49**) together with rear brake pedal and linkage assembly.
3. Remove the cotter pin and loosen the rear axle nut (A, **Figure 51**) and the rear drive belt adjusters (B).
 4. Remove the lower right shock absorber mounting bolt and belt guard.
 5. Mark the belt so that it can be installed in its original operating position.

CAUTION

When handling the drive belt, do not bend it backwards or twist it into loops smaller than 5 in. (127 mm). Doing so may weaken the belt causing premature failure.

6. Slide the drive belt (**Figure 52**) off the drive sprocket and remove it from the motorcycle.
7. Installation is the reverse of removal steps. Adjust the drive belt tension and tighten the rear axle nut as described in Chapter Three.
8. Make sure the rear brake is operating correctly. If the brake line was disconnected, bleed the rear brake as described in Chapter Sixteen.

Inspection**CAUTION**

When handling the drive belt, do not bend it backwards or twist it into loops smaller than 5 in. (127 mm). Doing so may weaken the belt causing premature failure.

The drive belt has a built-in polyethylene lubricant coating that burnishes off during break-in. Do not apply lubricants. Inspect the drive belt for wear or damage. Replace any belt that appears questionable. See **Figure 53**.

Drive Sprocket Removal/Installation

1. Remove the rear wheel as described in this chapter.
2. Shift the transmission into first gear.
3. Remove the rear sprocket cover (A, **Figure 49**) as follows:

NOTE

It is not necessary to disconnect the brake line at the master cylinder.

- a. Using an Allen wrench, loosen then remove the rear brake master cylinder mounting bolts (B, **Figure 49**) and washers.

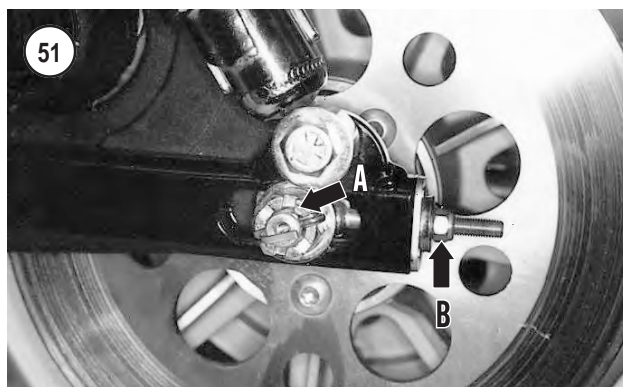

- b. On all models except 1999-2003 883C and 1200C, remove the clevis pin cotter pin at the rear brake pedal. Then remove the clevis pin (**Figure 50**) to disconnect the brake pedal from the brake rod end.
 - c. On 1999-2003 883C and 1200C models, remove the rear brake pedal as part of the forward foot controls as described in Chapter Seventeen.
 - d. Remove the screw and clip (C, **Figure 49**) securing the brake line to the sprocket cover.
 - e. Loosen then remove the Allen bolts and washers securing the sprocket cover to the engine. Remove the sprocket cover (A, **Figure 49**) together with rear brake pedal and linkage assembly.
4. Remove the cotter pin and loosen the rear axle nut (A, **Figure 51**) and the rear drive belt adjusters (B).

53 DRIVE BELT INSPECTION

1. Internal tooth cracks
2. Missing teeth
3. Fuzzy edge core
4. Stone damage
5. External tooth cracks
6. Chipping
7. Hook wear

54 DRIVE SPROCKET (1986-1991 MODELS AND 1992 MODELS WITH DRIVE CHAIN)

1. Drive belt (or drive chain)
2. Socket lockscrew
3. Main drive gear shaft
4. Drive sprocket
5. Sprocket nut

55 DRIVE SPROCKET (1992-2003 MODELS)

1. Main drive gear shaft
2. Drive sprocket
3. Sprocket nut
4. Lockplate
5. Socket head screw

5A. On 1991 models, loosen and remove the socket lockscrew (2, **Figure 54**).

5B. On 1992-2003 models, remove the two socket head screws and lockplate (**Figure 55**).

NOTE
The drive sprocket nut uses left-hand threads.

6. Turn the drive sprocket nut (**Figure 56**) clockwise and remove it from the main drive gear shaft.
7. Remove the drive sprocket (**Figure 57**).
8. Replace the drive sprocket if severely worn or damaged.
9. Install the drive sprocket (**Figure 57**) onto the main drive gear shaft.
10. The drive sprocket nut has a shoulder on one side (**Figure 58**). Install the nut so that the shoulder faces toward the drive sprocket.

NOTE

The drive sprocket nut uses left-hand threads.

11. Apply threadlock (Loctite 262 or equivalent) onto the sprocket nut threads. Then turn the nut (**Figure 56**) counterclockwise and thread it onto the main drive gear shaft. Tighten the nut to the torque specification in **Table 8**.

- 12A. On 1991 models, perform the following:

- a. Determine which one of the three drive sprocket lock screw sprocket holes aligns with a nut flat; see **Figure 54**. If none of the holes aligns with a nut flat, tighten the nut until one of the lock screw holes aligns with a nut flat.

CAUTION

If the drive sprocket nut requires additional tightening, do not exceed 150 ft-lb. (203 N•m). Do not loosen the drive sprocket nut to align the screw hole.

- b. Apply threadlock (Loctite 242 or equivalent) to the drive sprocket lock screw threads. Then install the lock screw into the correct sprocket hole so that it rests against the nut flat (**Figure 54**) and tighten to the torque specification in **Table 8**.

- 12B. On 1992-2003 models, perform the following:

- a. Install the lockplate onto the nut. Then position the lockplate so that two of the four lockplate holes (diagonally opposite) align with the two tapped sprocket screw holes; see **Figure 59**. If the lockplate doesn't align with the screw holes, tighten the nut until two holes align.

CAUTION

If the drive sprocket nut requires additional tightening, do not exceed 150 ft-lb. (203 N•m). Do not loosen the drive sprocket nut to align screw holes.

- b. Apply threadlock (Loctite 242 or equivalent) to the two drive sprocket lock screw threads. Then install the lock screws into the two tapped holes. Tighten the lock screws to 84-108 in.-lb. (9-12 N•m).

13. Reverse Steps 1-4 to complete assembly. Tighten the drive sprocket cover screws to 90-110 in.-lb. (10-12 N•m) and rear master cylinder screws to 155-190 in.-lb. (18-21 N•m).

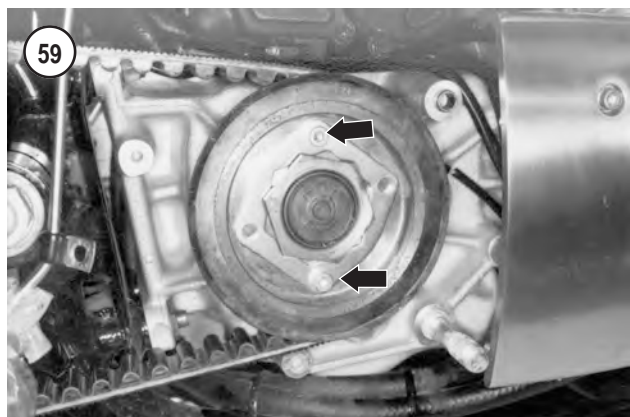
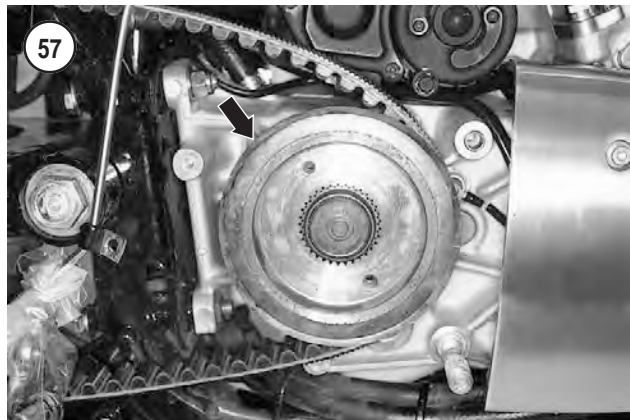

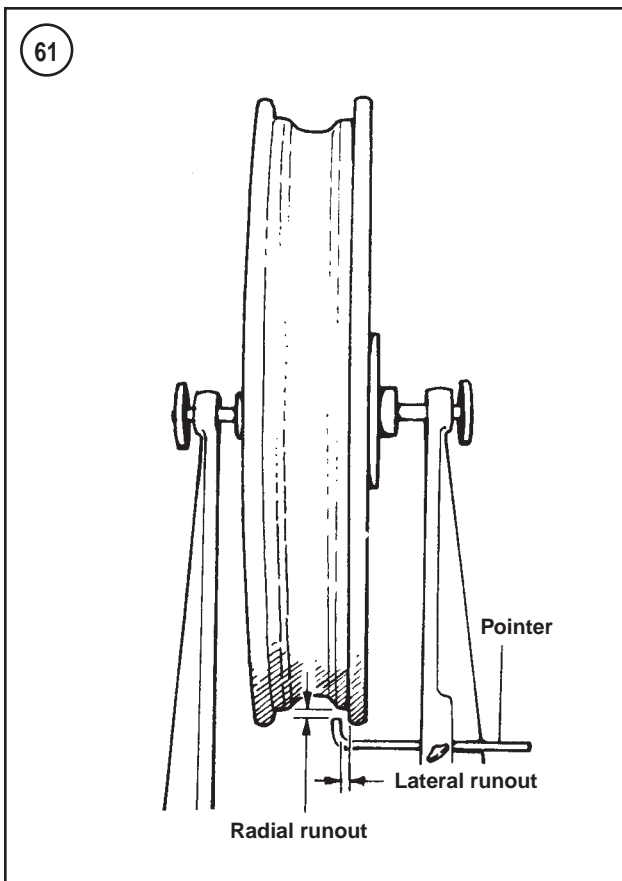
**WARNING**

Check that the rear brake is operating properly before riding the motorcycle.

14. If the rear master cylinder pushrod locknut was loosened, adjust the rear brake as described in Chapter Three.
15. Adjust the drive belt (Chapter Three).

Driven Sprocket Removal/Installation

The driven sprocket (rear) is bolted to the rear wheel (**Figure 60**).

1. Remove the rear wheel as described in this chapter.
2. Remove the bolts and nuts securing the sprocket to the hub and remove the sprocket.
3. Replace worn or damaged sprocket fasteners as required.
4. Installation is the reverse of the preceding steps while noting the following:
 - a. Apply threadlock (Loctite 262 or equivalent) to the sprocket bolts prior to installation.
 - b. Tighten the sprocket nuts and bolts to the torque specification in **Table 13**.

WHEEL RUNOUT

1. Remove the front or rear wheel as described in this chapter.
2. Install the wheel in a wheel truing stand and check the wheel for excessive wobble or runout.
3. If the wheel is not running true, remove the tire from the rim as described in this chapter. Then remount the wheel into the truing stand, and measure axial and lateral runout (**Figure 61**) with a pointer or dial indicator. Compare actual runout readings with the service limit specification in **Table 1**. Note the following:

WARNING

Do not try to repair damage to a disc wheel. Replace damage wheels.

- a. On disc or cast wheels, if the runout meets or exceeds the service limit in **Table 1**, check the wheel bearings as described in *Front Hub* or *Rear Hub* in this chapter. If the wheel bearings are acceptable, replace the cast or disc wheel as it cannot be serviced. Inspect the wheel for cracks, fractures, dents or bends. Replace a damaged wheel.
 - b. On laced wheels, if the wheel bearings, spokes, hub and rim assembly are not damaged, the runout can be corrected by truing the wheel. Refer to *Laced Wheels* in this chapter. If the rim is dented or damaged, replace the rim and rebuild the wheel.
4. While the wheel is off, perform the following:
 - a. Check the brake disc mounting bolts (**Figure 62**) for tightness as described in Chapter Sixteen.
 - b. On the rear wheel, check the driven sprocket bolts (**Figure 63**) as described in this chapter.

LACED WHEELS

The laced wheel assembly consists of a rim, spokes, nipples and hub containing the bearings, and spacer.

Inspection

Inspect the wheels regularly for lateral (side-to-side) and radial (up-and-down) runout, even spoke tension and visible rim damage. When a wheel has a noticeable wobble, it is out of true.

Truing a wheel corrects the lateral and radial runout to bring the wheel back into specification. The condition of the individual wheel components will affect the ability to successfully true the wheel. Note the following:

1. **Spoke condition**—Do not attempt to true a wheel with bent or damaged spokes. Doing so places an excessive amount of tension on the spoke and rim. The spoke may break and/or pull through the spoke nipple hole in the rim. Inspect the spokes carefully and replace any damaged spokes.
2. **Nipple condition**—When truing the wheels, the nipples should turn freely on the spoke. It is common for the spoke threads to become corroded and make turning the nipple difficult. Spray penetrating liquid onto the nipple and allow sufficient time for it to penetrate before trying to force the nipple loose. Work the spoke wrench in both directions and continue to apply penetrating liquid. If the spoke wrench rounds off the nipple, remove the tire from the rim and cut the spoke(s) out of the wheel.
3. **Rim condition**—Minor rim damage can be corrected by truing the wheel; however, trying to correct excessive runout caused by impact damage causes hub and rim damage due to spoke overtightening. Inspect the rims for cracks, flat spots or dents. Check the spoke holes for cracks or enlargement. Replace rims with excessive damage.

Wheel Truing

Preliminaries

Before checking runout and truing the wheel, note the following:

1. Make sure the wheel bearings are in good condition. Refer to *Front Hub* or *Rear Hub* in this chapter.
2. Verify that wheel runout is within specification. **Table 1** lists the lateral (side-to-side) and radial (up-and-down) runout limit specifications.
3. The runout can be checked on the motorcycle by mounting a pointer against the fork or swing arm and slowly rotating the wheel.
4. Perform major wheel truing with the tire removed and the wheel mounted in a truing stand (**Figure 64**). If a stand is not available, mount the wheel on the motorcycle with spacers on each side of the wheel to prevent it from sliding on the axle.

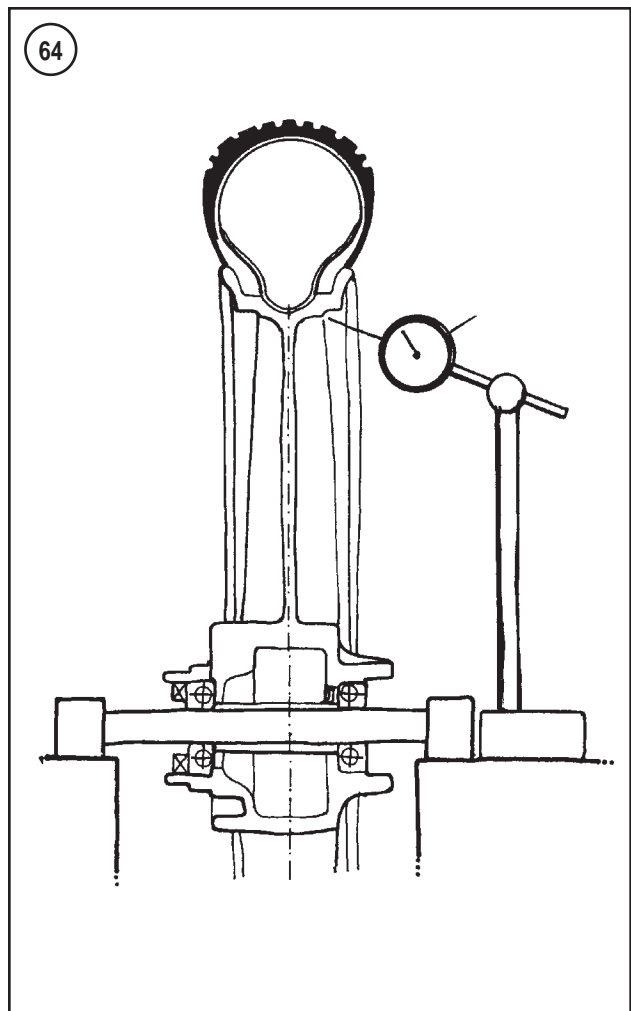

5. Use a spoke nipple wrench of the correct size. Using the wrong type of tool or one that is the incorrect size will round off the spoke nipples, making adjustment difficult.

Procedure

1. Position a pointer facing toward the rim (**Figure 61**). Spin the wheel slowly and check the lateral and radial runout. If the rim is out of adjustment, continue with Step 2.

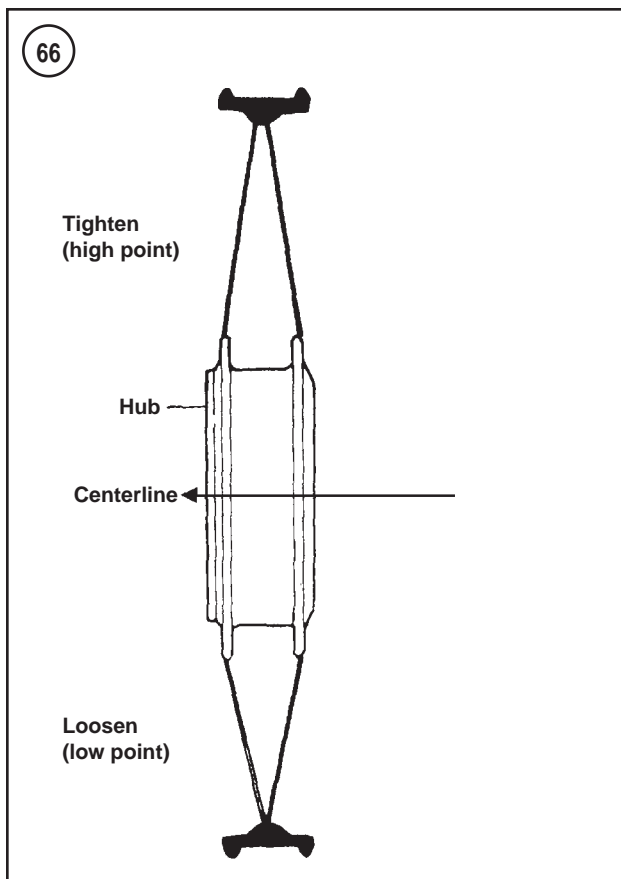
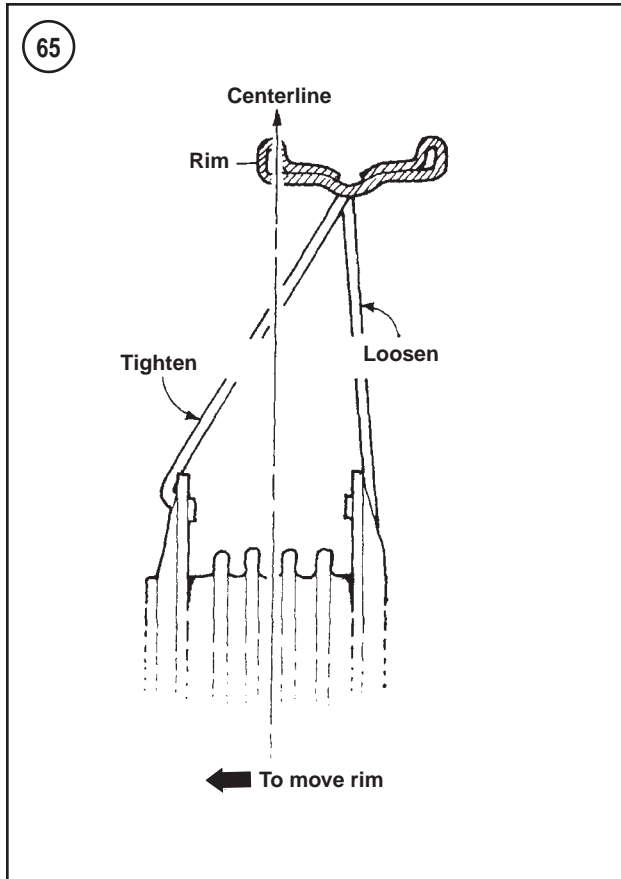

NOTE

If there is a large number of loose spokes, make sure the hub is centered in the rim. This must be done visually as there are no hub and rim centering specifications for these models.

NOTE

The number of spokes to loosen and tighten in Steps 2 and 3 depends on how far the runout is out of adjustment. As a minimum, always loosen two or three spokes, then tighten the opposite two or three spokes. If the runout is excessive and affects a greater area along the rim, a greater number of spokes will require adjustment.

2. If the lateral (side-to-side) runout is out of specification, adjust the wheel by using **Figure 65** as an example. To move the rim to the left, loosen and tighten the spokes as shown. Always loosen and tighten the spokes an equal number of turns.
3. If the radial (up and down) runout is out of specification, the hub is not centered in the rim. Draw the high point of the rim toward the centerline of the wheel by tightening the spokes in the area of the high point and on the same side as the high point, and loosening the spokes on the side opposite the high point (**Figure 66**). Tighten spokes in equal amounts to prevent distortion.
4. After truing the wheel, seat each spoke in the hub by tapping it with a flat nose punch and hammer. Then recheck the spoke tension and wheel runout. Readjust if necessary.
5. Check the ends of the spokes where they are threaded in the nipples. Grind off ends that protrude through the nipples.

DISC AND CAST WHEELS

Disc and cast wheels consist of a single assembly equipped with bearings, and a spacer.

While these wheels require less maintenance, they must be checked periodically for damage. Also, the disc wheel should be checked prior to installing a new tire. Wheel bearing service is described in this chapter.

Inspection

WARNING

Do not try to repair any damage to a disc or cast wheels. Replace damage wheels.

Before checking runout and truing the wheel, note the following:

1. Make sure the wheel bearings are in good condition. Refer to the *Front Hub* or *Rear Hub* in this chapter.
2. Perform wheel runout with the tire removed and the wheel mounted in a truing stand (**Figure 64**). If a stand is not available, mount the wheel on the motorcycle with

spacers on each side of the wheel to prevent it from sliding on the axle.

3. The maximum lateral (side-to-side) and radial (up-and-down) runout is listed in **Table 1**.

WHEEL BALANCE

An unbalanced wheel is unsafe. Depending on the degree of unbalance and the speed of the motorcycle, the rider may experience anything from a mild vibration to a violent shimmy that may causes loss of control.

On cast or disc wheels, weights are attached to the flat surface on the rim (**Figure 67**). On laced wheels, the weights are attached to the spoke nipples (**Figure 68**).

Before attempting to balance the wheel, make sure the wheel bearings are in good condition and properly lubricated. The wheel must rotate freely.

1. Remove the front or rear wheel as described in this chapter.
2. Mount the wheel on a fixture (**Figure 69**) so it can rotate freely.
3. Spin the wheel and let it coast to a stop. Mark the tire at the lowest point.
4. Spin the wheel several more times. If the wheel keeps coming to rest at the same point, it is out of balance.

NOTE

The maximum total allowable weight of all installed weights on a wheel is 3.5 oz. (866 g.). If the wheel cannot be balanced using the maximum allowable weights, inspect the wheel for damage.

5A. On cast or disc wheels, tape a test weight to the upper or light side of the wheel (**Figure 67**).

5B. On laced wheels, attach a weight to the spoke (**Figure 68**) on the upper or light side of the wheel.

6. Experiment with different weights until the wheel comes to a stop at a different position each time it is spun.

7. On cast or disc wheels, remove the test weight and install the correct size weight.

- a. Attach the weights to the flat surface on the rim (**Figure 67**). Clean the rim before installing the weights; otherwise, the weights may fall off.
 - b. Add weights in 1/4 oz. (7 g) increments. If 1 oz. (28 g) or more must be added to one location, apply half the amount to each side of the rim.
 - c. To apply original equipment wheel weights, remove the paper backing from the weight and apply three drops of Loctite 420 Superbond to the bottom of the weight. Position the weight on the rim, press it down and hold in position for 10 seconds. To allow the adhesive to cure properly, do not use the wheel for 8 hours.
8. When fitting weights on laced wheels for the final time, crimp the weights onto the spoke with slip-joint pliers.

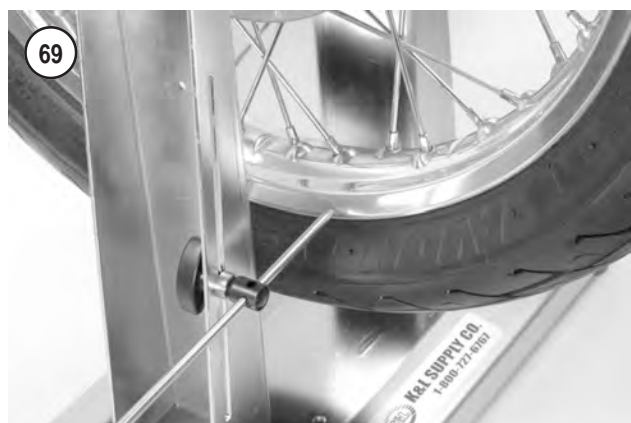

TIRES

Safety

Maintain the tire inflation pressure at the specification in **Table 2**. If a different brand of tire is used, follow the inflation recommendation provided by the tire manufacturer. Tire inflation specifications are cold inflation specifications. Do not check/adjust tire pressure after riding the motorcycle.

Always allow the tires to warm up by riding before subjecting them to high cornering loads. Warm tires provide more adhesion.

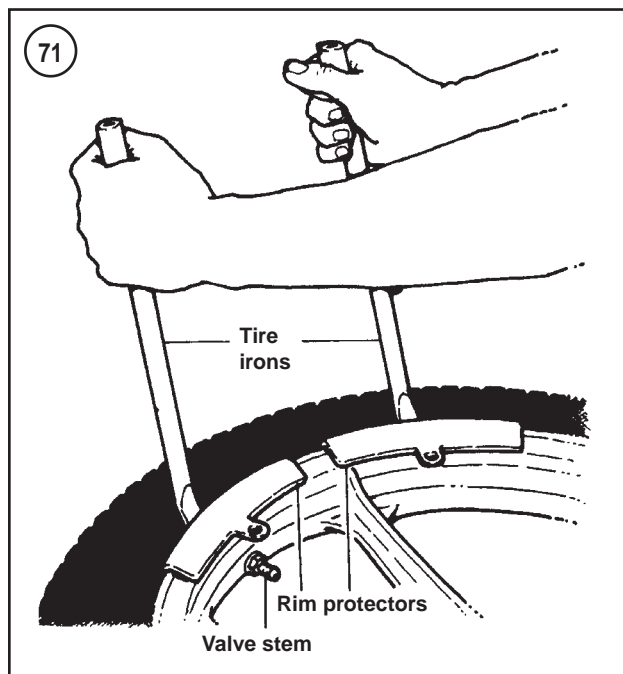
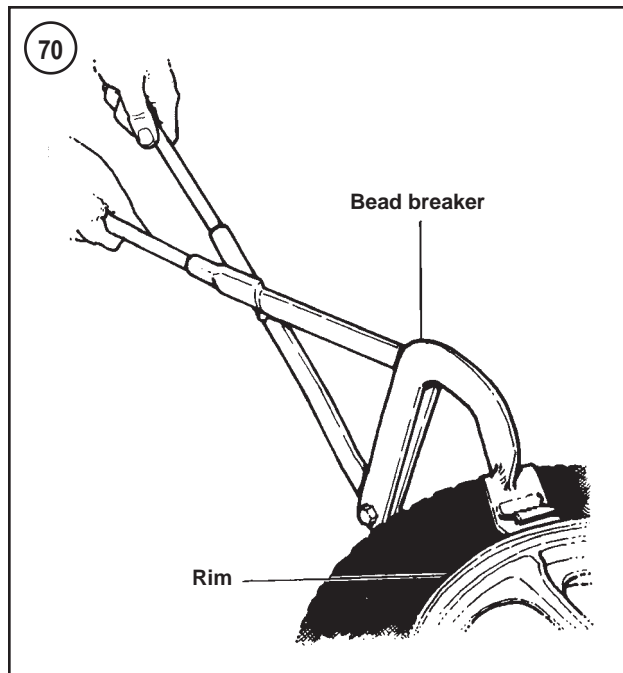

New tires provide significantly less adhesion until they are broken in. Do not subject new tires to high speed or high cornering forces for at least 60 mile (100 km). Be especially careful when encountering wet conditions with new tires.

Removal

CAUTION

To avoid damage when removing the tire, support the wheel on two wooden blocks, so the brake disc or the driven sprocket does not contact the floor.

NOTE

To make tire removal easier, warm the tire to make it softer and more pliable. Place the wheel and tire assembly in the sun. If possible, place the wheel assembly and the new tire in a completely closed automobile parked in the sun.

Take special care with tire irons when changing a tire to avoid scratches and gouges to the outer rim surface. Insert pads between the tire iron and the rim to protect the rim from damage.

All original equipment cast or disc wheels are designed for use with tubeless tires only. All laced wheels use a tube and tire combination.

When removing a tubeless tire, take care not to damage the tire beads, inner liner of the tire or the wheel rim flange. Use tire levers or flat handle tire irons with rounded heads.

1. Remove the front or rear wheel as described in this chapter.
2. If not already marked by the tire manufacturer, mark the valve stem location on the tire, so the tire can be installed in the same location for easier balancing.
3. Remove the valve cap and unscrew the core from the valve stem and deflate the tire or tube.

CAUTION

The inner rim and tire bead areas are the sealing surfaces on tubeless tires. Do not scratch the inside of the rim or damage the tire bead.

NOTE

Removal of tubeless tires from their rims can be difficult because of the tight tire bead-to-rim seal. Breaking the bead seal may require a special tool (Figure 70). If unable to break the seal loose, take the wheel to a dealership and have them break it loose on a tire changing machine.

4. Press the entire bead on both sides of the tire away from the rim and into the center of the rim. If the bead is tight, use a bead breaker.
5. Lubricate both beads with soapy water.

CAUTION

Use rim protectors (Figure 71, typical) or insert scraps of leather between the tire iron and the rim to protect the rim from damage.

CAUTION

Use only tire irons without sharp edges. If necessary, file the ends of the tire irons to remove rough edges.

6. Insert a tire iron under the top bead next to the valve stem (Figure 72). Force the bead on the opposite side of the tire into the center of the rim and pry the bead over the rim with the tire iron.

7. Insert a second tire iron next to the first iron to hold the bead over the rim. Then work around the tire with the first tire iron, prying the bead over the rim (**Figure 73**). On tube-type tires, be careful not to pinch the inner tube with the tools.

8. On tube-type tires, use a thumb and push the valve stem from its hole in the rim to the inside of the tire. Carefully pull the tube out of the tire and lay it aside.

9. To completely remove the tire, stand the wheel upright. Insert a tire iron between the back bead and the side of the rim that the top bead was pried over (**Figure 74**). Force the bead on the opposite side from the tire iron into the center of the rim. Work around the tire and pry the back bead off the rim. On tube-type tires, remove the rim band.

10. Inspect the valve stem seal. Because rubber deteriorates with age, replace the valve stem when replacing the tire.

11. On tubeless tires, remove the old valve stem and discard it. Inspect the valve stem hole (**Figure 75**) in the rim. Remove any dirt or corrosion from the hole and wipe it dry with a clean cloth. Install a new valve stem and make sure it is properly seated in the rim.

12. Inspect the tire and wheel rim for damage as described in this section.

Inspection

WARNING

Carefully consider whether a tire should be replaced. If there is any doubt about the quality of the existing tire, replace it with a new one. Do not take a chance on a tire failure at any speed.

1. Wipe off the inner surfaces of the wheel rim. Clean off any rubber residue or oxidation.

WARNING

Install only original equipment tire valves and valve caps. A valve or valve/cap combination that is too long or heavier than original equipment parts may interfere with an adjacent component when the motorcycle is under way. Damage to the valve will cause rapid tire deflation and loss of control.

2. On tubeless tires, inspect the valve stem rubber grommet for deterioration. If replacement is necessary, install only the original equipment valve stem assembly.

3. If any of the following conditions are observed, replace the tire:

- A puncture or split with a total length or diameter exceeds 0.24 in. (6 mm).
- A scratch or split on the sidewall.
- Any type of ply separation.
- Tread separation or excessive abnormal wear pattern.
- Tread depth of less than 1/16 in. (1.6 mm) on original equipment tires. Tread depth minimum may vary on aftermarket tires.

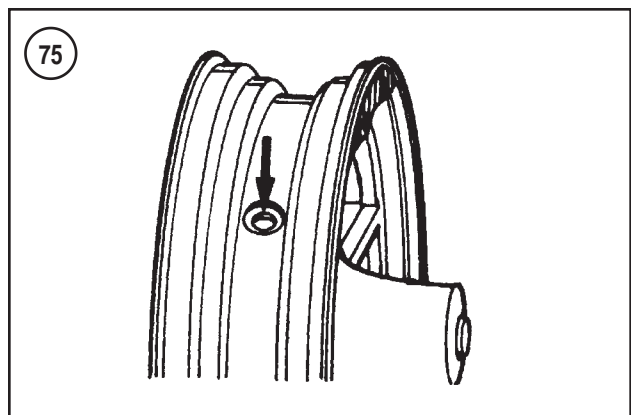

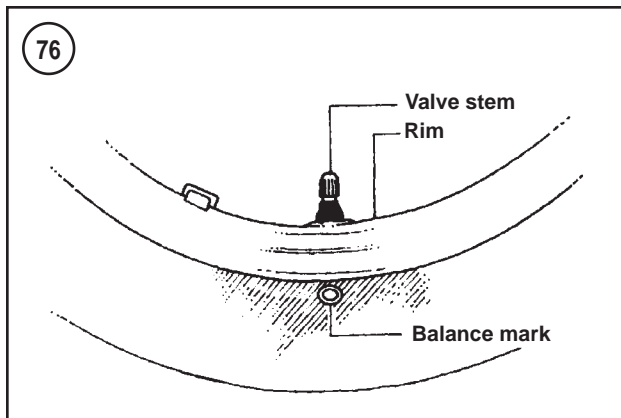

- f. Scratches on either sealing bead.
- g. The cord is cut in any place.
- h. Flat spots in the tread from skidding.
- i. Any abnormality in the inner liner.

Installation

1. A new tire may have balancing rubbers inside. These are not patches. Do not remove them. Most tires are marked with a colored spot near the bead (**Figure 76**) indicating a lighter point on the tire. This should be placed next to the valve stem.
2. On tube-type tires, install the rim band around the wheel and align the hole in the rim band with the hole in the rim. If installing a new rim band, make sure it is the correct diameter and width for the wheel.
3. Lubricate both beads of the tire with soapy water.
4. When installing the tire on the rim, make sure the correct tire, either front or rear, is installed on the correct wheel. Also make sure the direction arrow points in the direction of wheel rotation.
5. When remounting the old tire, align the mark made in Step 2 of *Removal* with the valve stem (**Figure 76**).
6. Place the backside of the tire onto the rim so the lower bead sits in the center of the rim while the upper bead remains outside the rim (**Figure 77**). Work around the tire in both directions and press the lower bead by hand into the center of the rim. Use a tire iron for the last few inches of bead.
7. On tube-type tires, perform the following:
 - a. Dust the inner tube with talcum powder before installing it in the tire. The talcum powder will prevent the tube from sticking to the tire.
 - b. Inflate the tube just enough to round it out. Too much air will make installation difficult.
 - c. Place the tube on top of the tire, aligning the valve stem with the matching hole in the rim. Insert the tube into the tire.
 - d. Lift the upper bead away from the rim with a hand and insert the tube's valve stem through the rim hole. Check to make sure the valve stem is straight up (90°), not cocked to one side. If necessary, reposition the tube in the tire. If the valve stem wants to slide out of the hole and back into the tire, install the valve stem nut at the top of the valve; do not tighten the nut at this time.
8. Press the upper bead into the rim opposite the valve stem. Working on both sides of this initial point, pry the bead into the rim with the tire tool, and work around the rim to the valve stem (**Figure 78**). On tube-type tires, do not pinch the inner tube during the last few inches. If the tire wants to pull up on one side, either use another tire iron or one knee to hold the tire in place. The last few inches are usually the toughest to install. Continue to push the tire into the rim by hand. Re-lubricate the bead if necessary. If the tire bead pulls out from under the rim, use both knees to hold the tire in place. If necessary, use a tire iron for the last few inches (**Figure 79**).

9. On tube-type tires, check to make sure that the valve stem is straight up (90°), not cocked to one side (**Figure 80**). If necessary, slide the tire along the rim in either direction while holding the rim securely. When the valve stem is straight up, tighten the valve stem nut at the top of the valve; do not tighten it against the rim at this time. Check that the tube was not forced out so that it rests between the tire bead and the rim. If necessary, push the tube back into the tire.

10. Bounce the wheel several times, rotating it each time. This will force the tire bead against the rim flanges. After the tire beads are in contact with the rim, inflate the tire to seat the beads.

11A. On tube-type tires, perform the following:

- Inflate the tube to its maximum tire pressure to seat the tire beads in the rim.
- After inflating the tire, make sure the beads are fully seated and the rim lines are the same distance from the rim all the way around the tire (**Figure 81**).
- If the tire beads do not seat properly, release the air pressure and re-lubricate the tire beads.
- When the tire is seated correctly, remove the valve core and deflate the tire allowing the tube to straighten out within the tire.
- Install the valve core and inflate the tire to the pressure in **Table 2**.
- Tighten the valve stem nut securely and install the valve stem cap.

11B. On tubeless tires/perform the following:

- Place an inflatable band around the circumference of the tire. Slowly inflate the band until the tire beads are pressed against the rim. Inflate the tire enough to make it seat, deflate the band and remove it.

WARNING

Never exceed 40 psi (276 kPa) inflation pressure as the tire could burst, causing severe injury. Never stand directly over a tire while inflating it.

- After inflating the tire, make sure the beads are fully seated and the rim lines are the same distance from the rim all the way around the tire (**Figure 82**). If the beads will not seat, deflate the tire and lubricate the rim and beads with soapy water.
- Re-inflate the tire to the pressure in **Table 2**. Install the valve stem cap.

- Check tire runout as described in this section.
- Balance the wheel as described in this chapter.
- Install the wheel as described in this chapter.

Tire Repairs

Tubeless

NOTE

Changing or patching on the road is very difficult. A can of pressurized tire inflator and

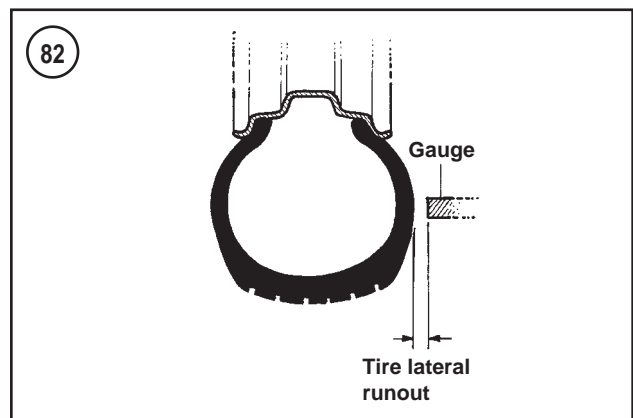
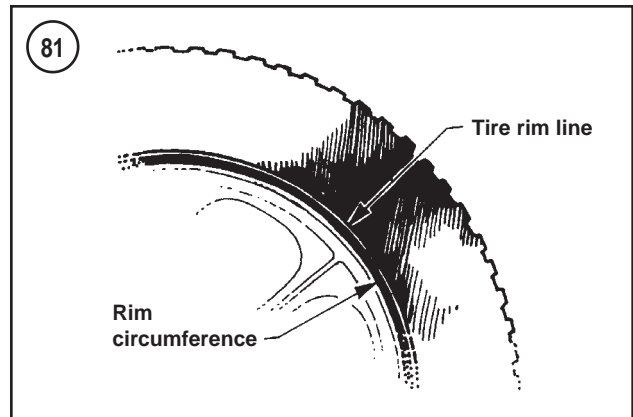
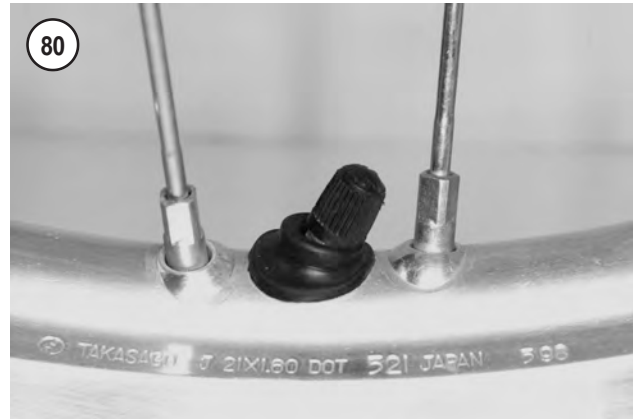

sealer can inflate the tire and seal the hole, but this is only a temporary fix.

Tubeless tires have the TUBELESS molded into the sidewall and the rims have SUITABLE FOR TUBELESS TIRES or equivalent stamped or cast on them.

If the tire is punctured, remove it from the rim to inspect the inside of the tire and apply a combination plug/patch from inside the tire (**Figure 83**). Never attempt to repair a tubeless motorcycle tire using a plug or cord patch applied from outside the tire.

After repairing a tubeless tire, do not exceed 50 mph (80 km/h) for the first 24 hours.

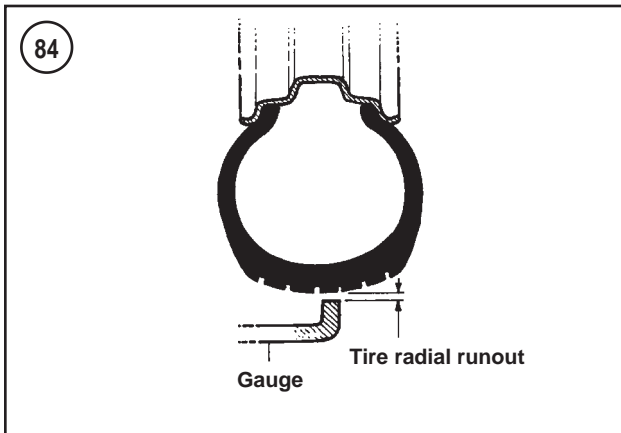
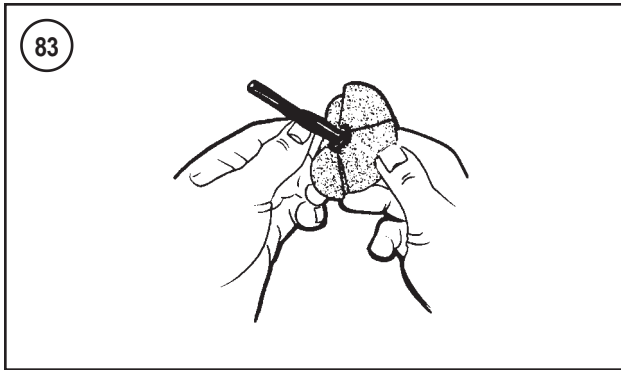
**WARNING**

Do not install an inner tube inside a tubeless tire. The tube will cause an abnormal heat buildup in the tire.

1. Remove the tire from the wheel rim as described in this section.
2. Inspect the rim inner flange. Smooth scratches on the sealing surface with emery cloth. If a scratch is deeper than 0.020 in. (0.5 mm), replace the wheel.
3. Inspect the inside and outside of the tire. Replace a tire if any of the following conditions are found.
 - a. A puncture larger than 1/8 in. (3 mm) diameter.
 - b. A punctured or damaged side wall.
 - c. More than two punctures in the tire.
4. Apply the plug/patch following the manufacturer's instructions.
5. As soon as possible, replace the patched tire with a new one.

Tube-type

Patching a motorcycle tube is only a temporary fix. A motorcycle tire flexes too much and a patch can rub off. As soon as possible, replace the tube with a new one.

When buying a tire repair kit, make sure it is for a motorcycle tire. Kits that vulcanize the patch to the tube with heat (hot patch) are strongest. Kits that attach the patch in place with adhesive are known as cold patch types.

1. Remove the tire from the wheel rim as described in this section.
2. Inspect the rim inner flange. Smooth scratches on the sealing surface with emery cloth. If a scratch is deeper than 0.020 in. (0.5 mm), replace the wheel.
3. Inspect the inside and outside of the tire. Replace a tire if any of the following conditions are found.
 - a. A puncture larger than 1/8 in. (3 mm) diameter.
 - b. A punctured or damaged side wall.
 - c. More than two punctures in the tire.
4. Apply the patch following the manufacturer's instructions.
5. As soon as possible, replace the patched tire with a new one.

Runout

Check the tires for excessive lateral and radial runout after a wheel has been mounted or if the motorcycle developed a wobble that cannot be traced to another component. Mount the wheels on their axles when making the following checks:

1. Check the tire for excessive lateral runout (side-to-side) as follows:
 - a. Position a fixed pointer next to the tire sidewall as shown in **Figure 82**. Position the pointer tip so it is not directly in line with the molded tire logo or any other raised surface.
 - b. Rotate the tire and measure lateral runout.
 - c. The lateral runout should not exceed 0.080 in. (2.03 mm). If runout is excessive, remove the tire from the wheel and recheck the wheel's lateral runout as described in this chapter. If the runout is excessive, the wheel must be trued (laced wheels) or replaced (alloy wheels). If wheel runout is correct, the tire runout is excessive and the tire must be replaced.
2. Check the tire for excessive radial runout (up-and-down) as follows:
 - a. Position a fixed pointer at the center bottom of the tire tread as shown in **Figure 84**.
 - b. Rotate the tire and measure the amount of radial runout.
 - c. The radial runout should not exceed 0.090 in. (2.29 mm). If runout is excessive, remove the tire from the wheel and recheck the wheel's radial runout as described in this chapter. If the runout is excessive, true (laced wheel) or replace the wheel. If wheel runout is correct, the tire runout is excessive and the tire must be replaced.

Table 1 FRONT AND REAR WHEEL SPECIFICATIONS

| | in. | mm |
|---------------------------------------|-----------------|----------------|
| Cast or disc wheel runout | | |
| Lateral | 0.040 | 1.02 |
| Radial | 0.030 | 0.76 |
| Laced wheel lateral and radial runout | 0.030 | 0.76 |
| Tire runout | | |
| Lateral | 0.08 | 2.03 |
| Radial | 0.09 | 2.29 |
| Wheel bearing end play | | |
| 1986-early 1991* | 0.004-0.018 | 0.10-0.46 |
| Late 1991-1999* | 0.002-0.006 | 0.05-0.15 |
| 2000-2003 models | | |
| Front wheel | Less than 0.002 | Less than 0.05 |
| Rear wheel | 0.002-0.006 | 0.05-0.15 |

*Refer to text for early and late 1991 identification.

Table 2 TIRE INFLATION PRESSURE (COLD)¹

| | psi | kPa |
|--------------------------------------|-----|-----|
| Up to 300 lb. load ² | | |
| Front | | |
| 1200 models | 30 | 207 |
| 883 and 1100 models | | |
| 1986-1990 | 26 | 179 |
| 1991-2003 | 30 | 207 |
| Rear | | |
| 1200 models | 36 | 248 |
| 883 and 1100 models | | |
| 1986-1990 | 30 | 207 |
| 1991-2003 | 36 | 248 |
| Up to GVWR maximum load ³ | | |
| Front | | |
| 1200 Models | 30 | 207 |
| 883 and XLH 1100 models | | |
| 1986-1990 | 26 | 179 |
| 1991-2003 | 30 | 207 |
| Rear | | |
| 1200 Models | 40 | 276 |
| 883 and XLH 1100 models | | |
| 1986-1990 | 32 | 221 |
| 1991-2003 | 40 | 276 |

1. Tire inflation pressure is for original equipment tires and must be take when the tire is cold. Aftermarket tires may require different inflation pressure.
2. 300 lb. load includes rider, passenger and cargo.
3. The gross vehicle weight rating (GVWR) is listed on a decal mounted on a decal mounted on the frame.

Table 3 FRONT WHEEL BEARING SPACER SLEEVES (1986-EARLY 1991 MODELS)

| Part No. | Length in. (mm) | Color code |
|----------|--------------------|------------|
| 43623-78 | 2.564 (65.12) | Violet |
| 43624-78 | 2.550 (64.77) | Pink |
| 43625-78 | 2.536 (64.41) | Gold |

Table 4 FRONT WHEEL BEARING SPACER SHIMS (LATE 1991-1999 MODELS)

| Part No. | Length in. (mm) |
|----------|-----------------------------|
| 43290-82 | 0.030-0.033 (0.76-0.84) |
| 43291-82 | 0.015-0.017 (0.38-0.43) |
| 43292-82 | 0.0075-0.0085 (0.191-0.216) |
| 43293-82 | 0.0035-0.0045 (0.089-0.114) |
| 43294-82 | 0.0015-0.0025 (0.038-0.064) |

Table 5 REAR WHEEL BEARING SPACER SLEEVES—CAST WHEEL (1986-EARLY 1991 MODELS)

| Part No. | Length in. (mm) | Color code |
|----------|--------------------|------------|
| 43604-78 | 4.420 (112.27) | Orange |
| 43605-78 | 4.434 (112.62) | Yellow |
| 43606-78 | 4.448 (112.98) | White |

Table 6 REAR WHEEL BEARING SPACER SLEEVES—LACED WHEEL (1986-EARLY 1991 MODELS)

| Part No. | Length in. (mm) | Color code |
|-----------|--------------------|------------|
| 43601-78A | 4.420 (112.27) | Orange |
| 43602-78A | 4.434 (112.62) | Yellow |
| 43603-78A | 4.448 (112.98) | White |

Table 7 REAR WHEEL BEARING SPACER SHIMS (LATE 1991-1999 MODELS)

| Part No. | Length in. (mm) |
|----------|-----------------------------|
| 43290-82 | 0.030-0.033 (0.76-0.84) |
| 43291-82 | 0.015-0.017 (0.38-0.43) |
| 43292-82 | 0.0075-0.0085 (0.191-0.216) |
| 43293-82 | 0.0035-0.0045 (0.089-0.114) |
| 43294-82 | 0.0015-0.0025 (0.038-0.064) |

Table 8 TUBELESS TIRE SPECIFICATIONS (1986 MODELS)

| | |
|--------------------------|--------------------|
| Front tire | |
| Type | Dunlop K181 |
| Size | MJ90-19 |
| Wheel diameter | 19 in. |
| Rim width and contour | T19 x 2.15 MT |
| Valve stem hole diameter | 0.45 in. (11.4 mm) |
| Rear tire | |
| Type | Dunlop K181 |
| Size | MT90-16 |
| Wheel diameter | 16 in. |
| Rim width and contour | T16 x 3.00 D |
| Valve stem hole diameter | 0.45 in. (11.4 mm) |

Table 9 TUBELESS TIRE SPECIFICATIONS (1987-1990 MODELS)

| | |
|--------------------------|---------------------|
| Front tire | |
| Type | Dunlop K181 or K291 |
| Size | MJ90-19 |
| Wheel diameter | 19 in. |
| Rim width and contour | T19 x 2.15 MT |
| Valve stem hole diameter | 0.45 in. (11.4 mm) |
| Rear tire | |
| Type | Dunlop K181 or K291 |
| Size | MT90-16 |
| Wheel diameter | 16 in. |
| Rim width and contour | T16 x 3.00 D |
| Valve stem hole diameter | 0.45 in. (11.4 mm) |

Table 10 TUBELESS TIRE SPECIFICATIONS (1991-2003 MODELS)

| | |
|--------------------------|---------------------------|
| Front tire | |
| Type | Dunlop D401 Elite S/T |
| Size | 100/90-19 |
| Wheel diameter | 19 in. |
| Rim width and contour | T19 × 2.15 MT |
| Valve stem hole diameter | 0.45 in. (11.4 mm) |
| Type | Dunlop K591 S&FR Elite SP |
| Size | 100/90-V19 |
| Wheel diameter | 19 in. |
| Rim width and contour | T19 × 2.15 MT |
| Valve stem hole diameter | 0.45 in. (11.4 mm) |
| Rear tire | |
| Type | Dunlop D401 Elite S/T |
| Size | 130/90-16 |
| Wheel diameter | 16 in. |
| Rim width and contour | T16 × 3.0 D |
| Valve stem hole diameter | 0.35 in. (8.9 mm) |
| Type | Dunlop K591 S&FR Elite SP |
| Size | 130/90-V16 |
| Wheel diameter | 16 in. |
| Rim width and contour | T16 × 3.0 D |
| Valve stem hole diameter | 0.35 in. (8.9 mm) |

Table 11 TUBE-TYPE TIRE SPECIFICATIONS (1986-1990 MODELS)

| | |
|-----------------------|---------------------|
| Front tire | |
| Type | Dunlop K181 or K291 |
| Size | MJ90-19 |
| Wheel diameter | 19 in. |
| Rim width and contour | T19 × 2.50 MTA |
| Tube size | MJ90-19 |
| Rear tire | |
| Type | Dunlop K181 or K291 |
| Size | MT90-16 |
| Wheel diameter | 16 in. |
| Rim width and contour | T16 × 3.00 D |
| Tube size | MT90-16 |

Table 12 TUBE-TYPE TIRE SPECIFICATIONS (1991-2003 MODELS)

| | |
|-----------------------|--|
| Front tire | |
| Type | Dunlop D401 Elite S/T |
| Size | 100/90-19 |
| Wheel diameter | 19 in. |
| Rim width and contour | T19 × 2.5 TLA |
| Tube size | MJ90-19 |
| Type | Dunlop Touring Elite II (1995-1999 models) |
| Size | MH90-21 56H |
| Wheel diameter | 21 in. |
| Rim width and contour | T21 × 215 TLA |
| Tube size | 3.00-21 |
| Type | Dunlop D401 Elite S/T (2000-2003 models) |
| Size | MH90-21 56H |
| Wheel diameter | 21 in. |
| Rim width and contour | T21 × 215 TLA |
| Tube size | 3.00-21 |
| Rear tire | |
| Type | Dunlop D401 Elite S/T |
| Size | 130/90-16 |
| Wheel diameter | 16 in. |
| Rim width and contour | T16 × 3.00 D |
| Tube size | MT90-16 |
| Type | Dunlop Touring Elite II (1995-1999 models) |
| Size | MT90-B16 |
| Wheel diameter | 16 in. |
| Rim width and contour | T16 × 3.00 D |
| Tube size | MT90-16 |

Table 13 WHEEL AND SUSPENSION TORQUE SPECIFICATIONS

| | ft.-lb. | in.-lb. | N•m |
|---|----------------|----------------|------------|
| Drive sprocket cover screws | – | 90-110 | 10-12 |
| Drive sprocket lockscrew ^{1,2} | | | |
| Chain drive | – | 50-60 | 6-7 |
| Belt drive | – | 84-108 | 9-12 |
| Drive sprocket nut ^{1,2} | | | |
| 1986-1990 models | 35-64 | – | 47-87 |
| 1991-2003 models ³ | 110-120 | – | 149-163 |
| Driven sprocket mounting bolts ⁴ | | | |
| Cast wheels | | | |
| 1991 models | 65-70 | – | 88-95 |
| 1992 models | 45-55 | – | 61-75 |
| 1993-2003 models | 55-65 | – | 75-88 |
| Laced wheels | 50-55 | – | 37-75 |
| Front axle nut | | | |
| 1986-1987 models | 50 | – | 68 |
| 1988-2003 models | 50-55 | – | 68-75 |
| Front axle pinch bolt (1988-2003 models) | 21-27 | – | 28-37 |
| Front brake caliper bolts | 25-30 | – | 34-41 |
| Fork lower cap nuts (1986-1987 models) | – | 132 | 15 |
| Hub plate Torx screws | 16-24 | – | 22-33 |
| Rear axle nut | 60-65 | – | 81-88 |
| Rear master cylinder screws | – | 155-190 | 18-21 |
| <p>1. See text. 2. Apply threadlock (Loctite 262 or equivalent). 3. Left-hand threads 4. Apply threadlock (Loctite 242 or equivalent).</p> | | | |

CHAPTER FOURTEEN

FRONT SUSPENSION AND STEERING

This chapter covers the handlebar, front fork and steering components. Refer to Chapter Thirteen for front wheel and tire service. **Tables 1-3** are at the end of this chapter.

WARNING

Replace all fasteners used on the front suspension and steering components with parts of the same type. Do not use a replacement part of lesser quality or substitute design; this may affect the performance of the system or result in failure of the part that leads to loss of motorcycle control. Careful attention to the torque specifications during installation is required to ensure proper retention of these parts.

HANDLEBAR

Inspect the handlebar at regular intervals for loose mounting bolts or damage. Frequently check the fasteners securing the master cylinder and turn signals to the handlebar. Make sure no fastener is loose or missing.

Replace the handlebar if it is bent or damaged. Never try to heat, bend or weld handlebars.

Removal

Refer to **Figure 1** and **Figure 2**.

1. Position the motorcycle on a suitable stand.
2. Remove the mirrors.

CAUTION

Cover the front fender and front wheel with a heavy cloth or plastic tarp to protect them from accidental brake fluid spills. Brake fluid can damage painted and plastic surfaces. Immediately wash the surfaces that come into contact with brake fluid with soapy water and rinse completely.

3. Remove the bolts securing the master cylinder (A, **Figure 3**). Support the master cylinder so it does not hang from the brake line. Make sure brake fluid does not spill from the master cylinder.

NOTE

Make a drawing of the clutch and throttle cable routing before removal.

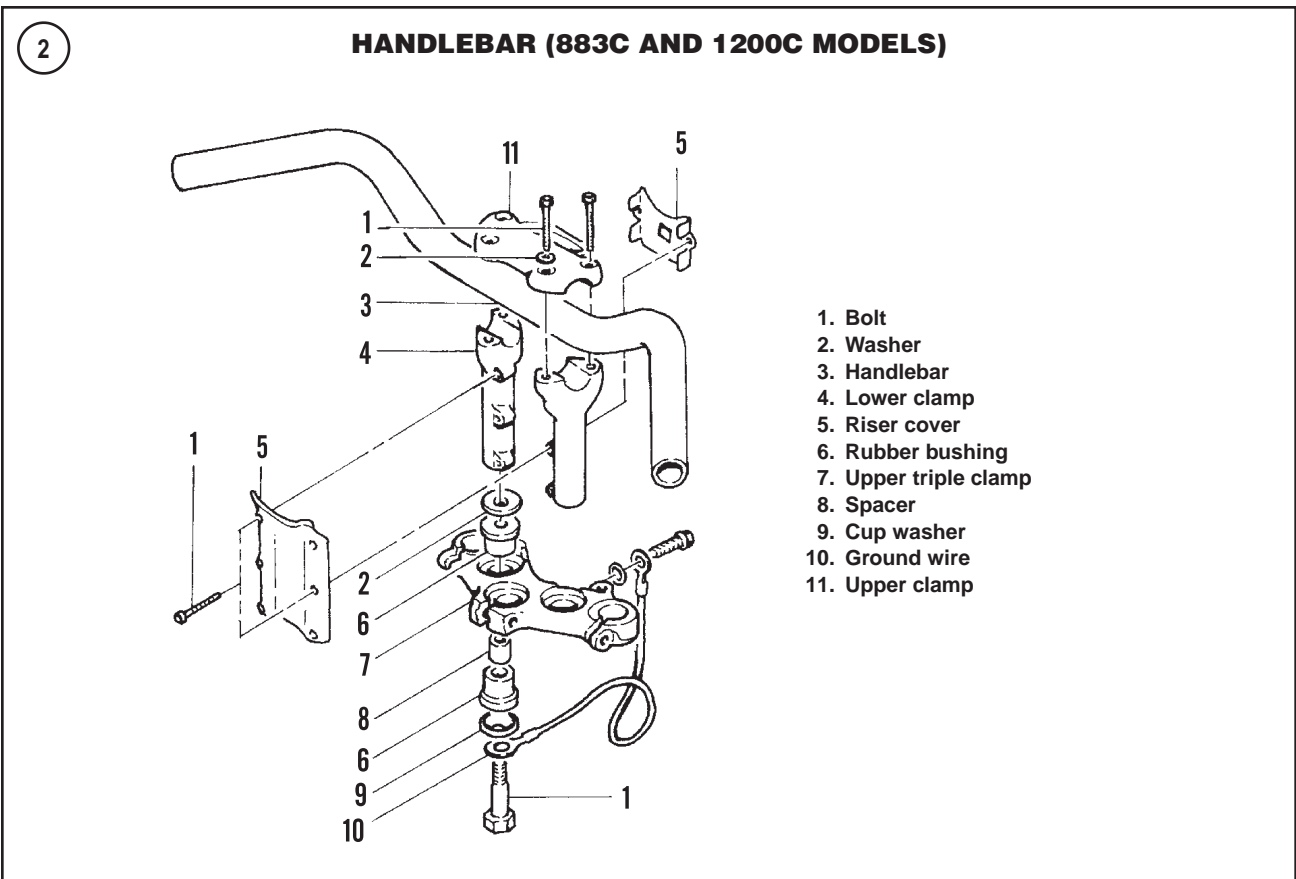
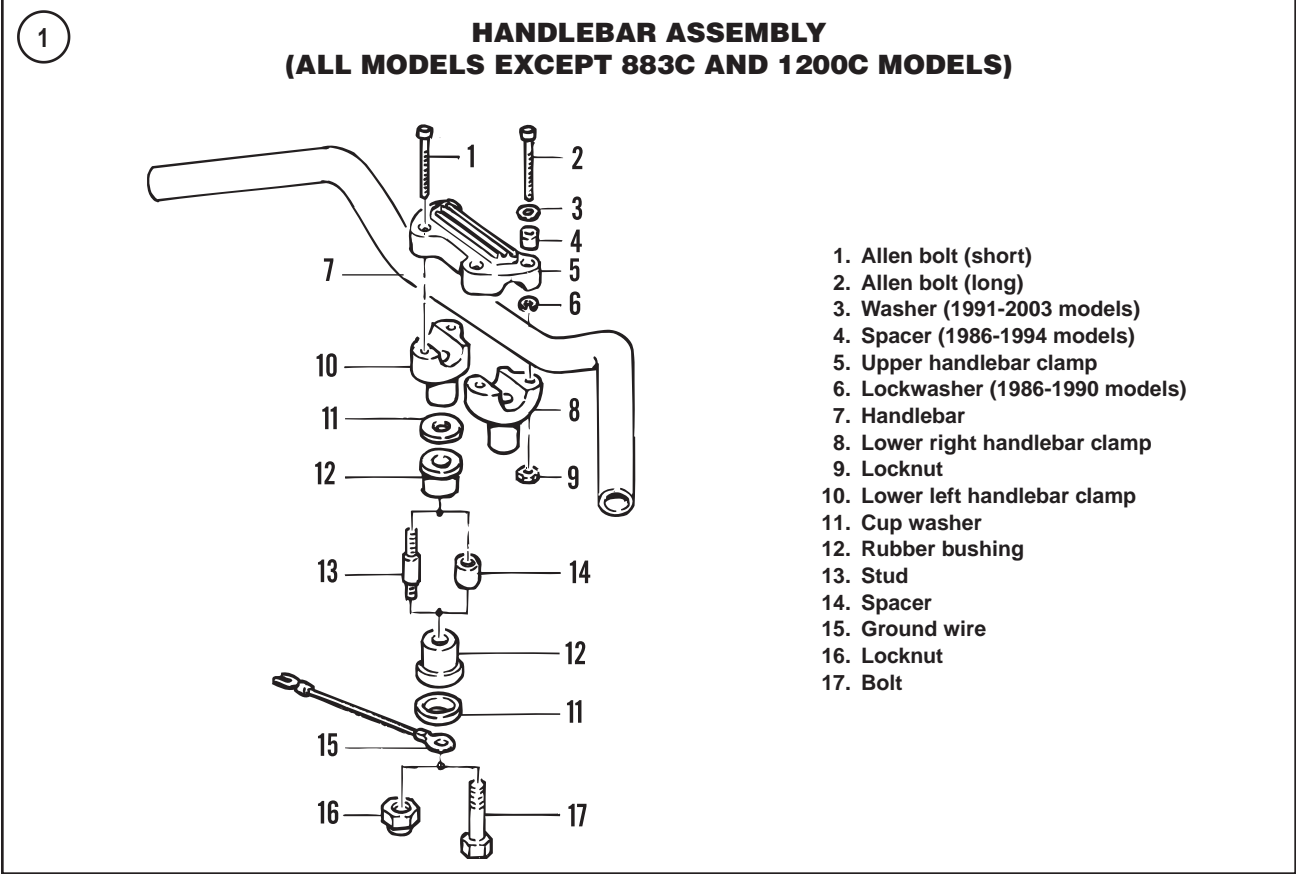

4. Loosen the throttle housing (B, **Figure 3**) screws so that the housing can slide off of the handlebar later in this procedure. It is not necessary to separate the housing halves.
5. Remove the left switch housing (A, **Figure 4**) screws and separate the housing halves (**Figure 5**).
6. Remove the clutch lever clamp mounting screws (B, **Figure 4**) and separate the clamp halves.
7. Disconnect or remove any clamps securing electrical cables to the handlebar.
8. On 883C and 1200C models, remove the riser covers.
9. If lower handlebar holder removal is required, loosen the holder bolts or nuts, but do not remove the bolts or nuts.
10. Loosen the handlebar clamp bolts (**Figure 6**). Remove the handlebar clamp bolts, then remove the instrument cluster and clamp. Do not lose the washers or spacers, if so equipped.
11. Remove the handlebar.

Inspection

1. Clean the knurled section of the handlebar with a wire brush and remove any debris in the knurling.
2. Check the handlebar for cracks, bends or other damage. Replace the handlebar if necessary. Do not attempt to repair it.
3. Clean the clamps and holders thoroughly before installing the handlebar.

Installation

1. Install the handlebar in the lower holder(s).
- 2A. On all models except 883C and 1200C, install the clamp and instrument housing using the following procedure:
 - a. Install the handlebar clamp and two rear clamp bolts.
 - b. Install the instrument housing and two front clamp bolts.
 - c. Tighten the rear clamp bolts first, then tighten the front clamp bolts. Tighten the clamp bolts to 144-180 in.-lb. (16-20 N•m).
- 2B. On 883C and 1200C models, install the clamp and instrument housing as follows:
 - a. Install the handlebar clamp and two front clamp bolts.
 - b. Install the instrument housing and two rear clamp bolts.
 - c. Tighten the front clamp bolts first, then tighten the rear clamp bolts. Tighten the clamp bolts to 144-180 in.-lb. (16-20 N•m).
 - d. Install the riser covers.
3. After installing the handlebar, sit on the motorcycle and check the handlebar position. Adjust the handlebar as needed.

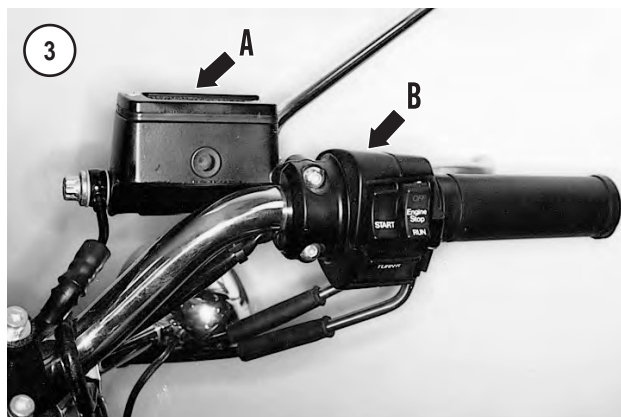

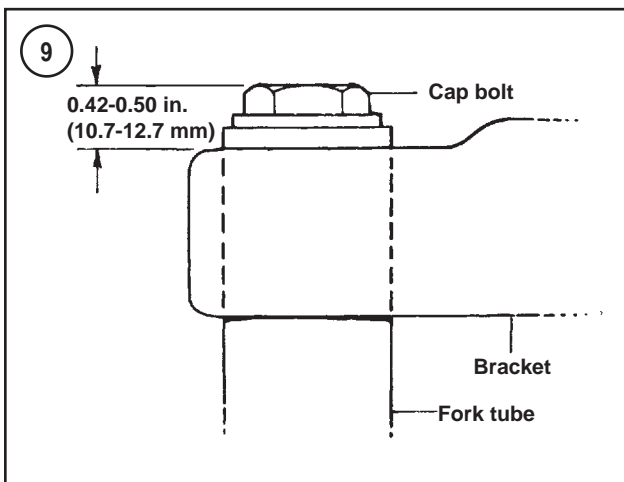
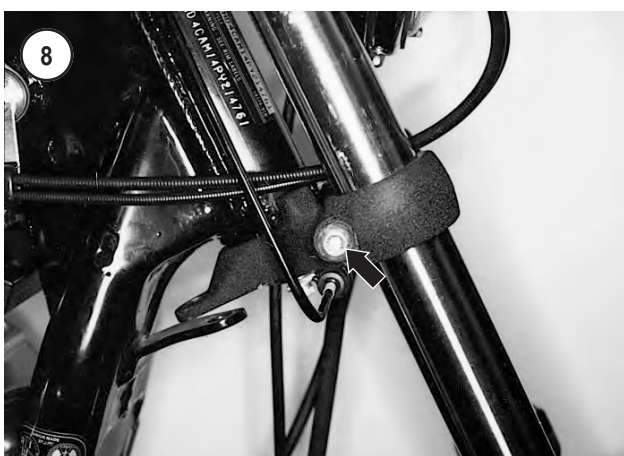

4. Install the right switch housing (Chapter Twelve).
5. Install the left switch housing (Chapter Twelve).
6. Install the clutch lever (Chapter Three).
7. Refer to Chapter Sixteen and install the front master cylinder onto the handlebar.
8. Reinstall the wiring and cable retaining clamps.
9. Install the mirrors.

FRONT FORK (ALL MODELS EXCEPT 1200S)

The front suspension consists of a spring-controlled, hydraulically dampened telescopic fork.

Before suspecting major trouble, drain the front fork oil and refill with the proper type and quantity (Chapter Three). If the trouble persists, such as poor damping, a tendency to bottom or top out or leaks around the rubber seals, follow the service procedures in this section.

To simplify fork service and to prevent the mixing of parts, remove, service and install the legs individually.

Removal

1. Support the motorcycle so the front wheel clears the ground. Make sure the motorcycle is stable before removing the front wheel and fork.
2. Remove the front wheel as described in Chapter Thirteen.
3. Remove the front fender as described in Chapter Seventeen.
4. On models equipped with a lower fork stem cover, loosen the cover screws and raise the cover for access to the lower fork pinch bolts.

NOTE

Label the left and right fork tubes so they can be reinstalled in their original positions,

5. Loosen the upper fork bracket pinch bolt (A, **Figure 7**).
6. If fork tube disassembly is required, loosen but do not remove the fork cap (B, **Figure 7**).
7. On 1986-1987 models, remove the cap bolt (B, **Figure 7**).
8. Loosen the lower fork bracket pinch bolt (**Figure 8**) and slide the fork tube out of the fork brackets. If necessary, rotate the fork tube while removing it.
9. If fork service is required, refer to *Disassembly* in this section.

Installation

NOTE

The fork assemblies must be reinstalled on the correct side of the motorcycle so the brake caliper and front fender can be properly installed. If the fork assemblies are installed on the wrong side, the bolt holes on these components will not align properly.

1. Clean off any corrosion or dirt on the upper and lower fork bracket receptacles.
2. On 1988-2003 models, install each fork tube so the tube extends 0.42-0.50 in. (10.7-12.7 mm) above the upper fork bracket as shown in **Figure 9**.
3. Tighten the lower bracket pinch bolt (**Figure 8**) to 30 ft.-lb. (14 N•m).
4. If loose, tighten the fork cap (B, **Figure 7**) securely.

10

**FRONT FORK
(ALL MODELS EXCEPT 1995-2003 1200S)**

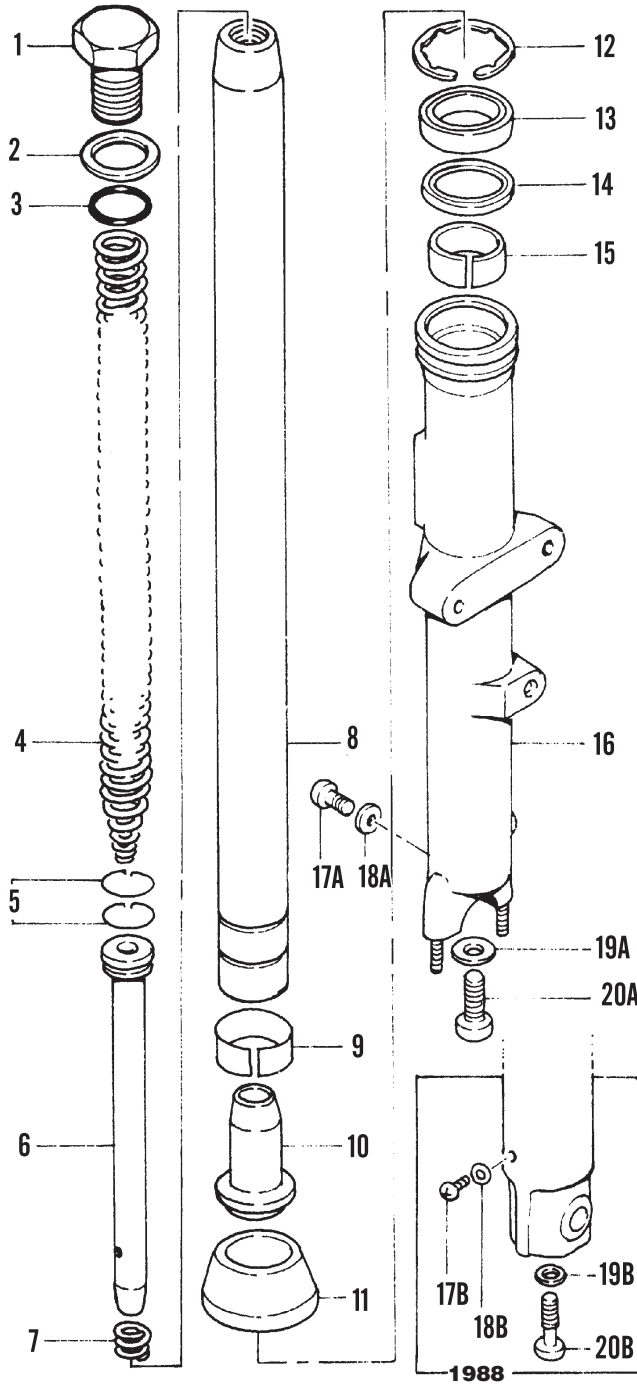

- 1. Cap bolt
- 2. Washer
(1986-1987 models)
- 3. O-ring
- 4. Spring
- 5. Piston rings
- 6. Damper rod
- 7. Rebound spring
- 8. Fork tube
- 9. Lower bushing
- 10. Oil lock piece
- 11. Dust cover
- 12. Retaining ring
- 13. Oil seal
- 14. Seal spacer
- 15. Upper bushing
- 16. Slider
- 17A. Drain screw
(1986-1987 models)
- 17B. Drain screw
(1988-2003 models)
- 18A. Washer
(1986-1987 models)
- 18B. Washer
(1988-2003 models)
- 19A. Washer
(1986-1987 models)
- 19B. Washer
(1988-2003 models)
- 20A. Allen bolt
(1986-1987 models)
- 20B. Allen bolt
(1988-2003 models)

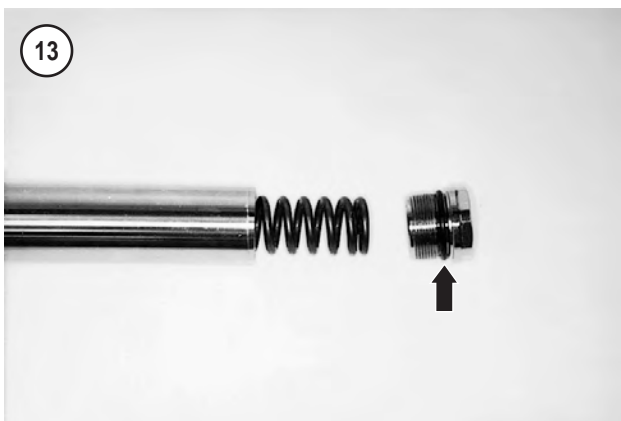
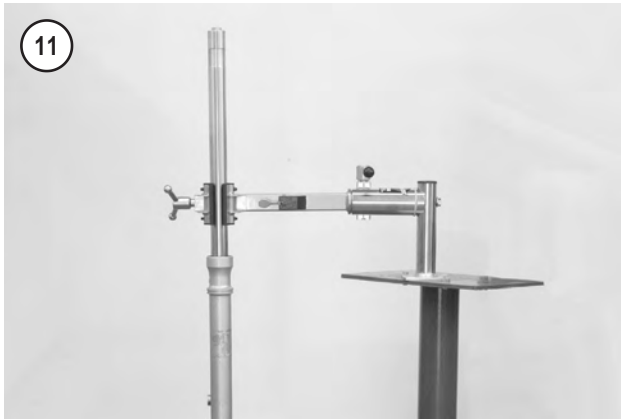

5. Tighten the upper bracket pinch bolt (A, **Figure 7**) to the torque specification in **Table 1**.
6. Install the front fender as described in Chapter Seventeen.
7. Install the front wheel as described in Chapter Thirteen.
8. Apply the front brake and operate the front fork several times to seat the fork and front wheel.

Disassembly

Refer to **Figure 10**.

NOTE

*Fork holding tools are available (**Figure 11**, typical), and such a tool may be shown in the following illustrations. However, the text refers to the use of a vise as a holding tool.*

1. Using the front axle boss at the bottom of the fork tube, clamp the slider in a vise with soft jaws. Do not clamp the slider at any point above the fork axle boss.

NOTE

Loosen the bottom Allen bolt before removing the fork cap and spring. Leaving the cap on provides spring tension against the damper rod. This prevents the damper rod from spinning when attempting to loosen the Allen bolt.

2. Loosen, but do not remove, the Allen bolt (**Figure 12**) at the bottom of the slider.

WARNING

Keep body parts away from the fork cap when removing it. The fork cap is under spring pressure and may fly off when loosening it. In addition, make sure the fork tube is fully extended from the slider. If the fork is damaged and stuck in a compressed state, the fork should be disassembled by a dealership.

3. Remove the fork cap (**Figure 13**) from the top of the fork tube. Then pull the spring out of the fork tube.
4. Remove the fork tube from the vise and pour the oil into a drain pan. Pump the fork several times by hand to get most of the oil out. Check the oil for contamination, indicating worn or damaged parts. Discard the oil after examining it.
- 5A. On 1986-1987 models, insert a small flat-tipped screwdriver under the dust cover (11, **Figure 10**) and pry the cover off of the slider and remove it. Be careful not to damage the slider surface.
- 5B. On 1988-2003 models, insert a small punch in the notch under the dust cover (**Figure 14**) and drive the cover off the slider and remove it. Do not damage the slider surface.



6. Insert a small flat-tipped screwdriver under the dust seal (**Figure 15**) and pry the seal out of the slider and remove it. Do not damage the slider surface.

7. Pry the retaining ring (**Figure 16**) out of the groove in the slider and remove it. See **Figure 17**.

8. Remove the Allen screw and washer (**Figure 18**) at the bottom of the slider.

NOTE

The slider bushing is installed with an interference fit. When separating the fork tube and slider, the slider bushing, spacer seal and oil seal will be removed at the same time.

9. Hold the fork tube in one hand then pull the slider away repeatedly, knocking the slider bushing against the fork tube bushing (**Figure 19**). As the slider bushing is knocked out of the slider, it will push the oil seal and seal spacer out of the slider. Continue until these components are pushed out of the slider.

10. Remove the oil lock piece (**Figure 20**) from the damper rod.

11. Remove the damper rod and small spring (**Figure 21**) from the fork tube.

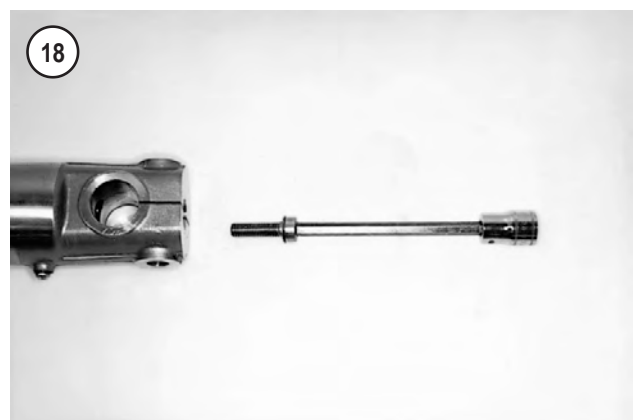

Inspection

NOTE

*Handle the guide bushings (**Figure 22**) carefully when cleaning them to avoid scratching or removing any of their coating material. If there is any metal powder clinging to the guide bushings, clean them with new fork oil and a nylon brush.*

1. Initially clean all of the fork components in solvent, first making sure the solvent will not damage the rubber parts. Then clean with soap and water and rinse with clear water. Dry thoroughly.

2. Check the fork tube (A, **Figure 23**) for bends, nicks, rust or other damage. Check the fork tube for straightness with a set of V-blocks and a dial indicator. If these tools are not available, roll the fork tube on flat surface like a place of glass. The manufacturer does not provide service limit

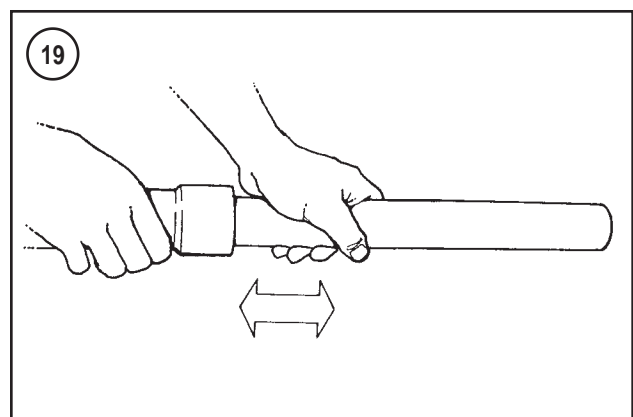

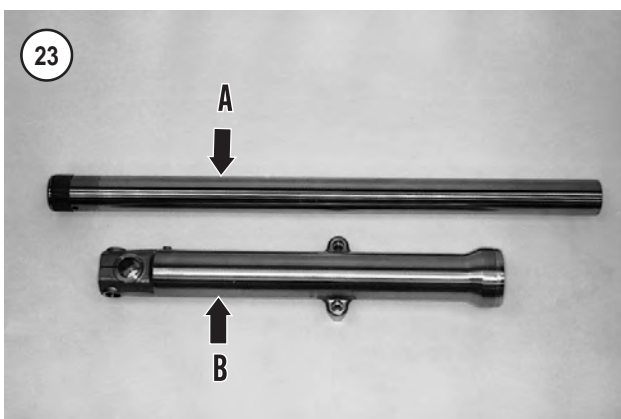
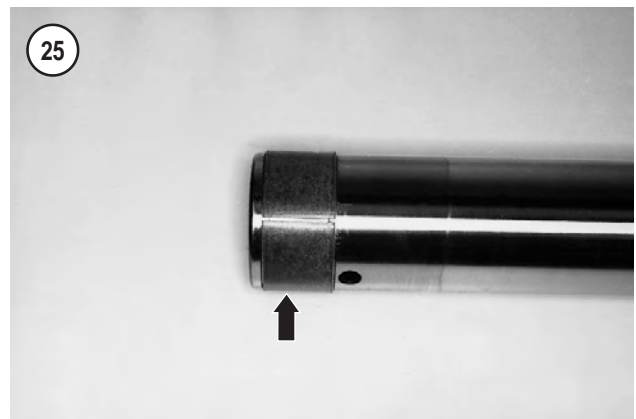

specifications for runout. If a fork tube is slightly bent, check with a dealership to see if it can be straightened. If a fork tube is creased or wrinkled, replace the fork tube.

3. Check the slider (B, **Figure 23**) for dents or other exterior damage. Check the retaining ring groove (**Figure 24**) in the top of the slider for cracks or other damage. Replace the slider if the groove is cracked or damaged.

4. Check the slider and fork tube bushings (**Figure 25**) for severe wear, cracks or damage. The slider bushing was removed with the oil seal. The fork tube bushing should not be removed unless replacement is required. To replace the fork tube bushing, perform the following:

- a. Expand the bushing slit using a screwdriver and slide it off the fork tube.
- b. Coat the new bushing with new fork oil.
- c. Install the new bushing by expanding the slit using a screwdriver. Expand the bushing only enough to fit it over the fork tube.
- d. Seat the new bushing (**Figure 25**) into the groove in the fork tube.

5. Replace the drain screw, Allen bolt or washers if damaged.

6. Check the damper rod piston rings (**Figure 26**) for severe wear, cracks or other damage. If necessary, replace both rings as a set.

7. Check the damper rod for straightness using a set of V-blocks and a dial indicator (**Figure 27**) or by rolling it on

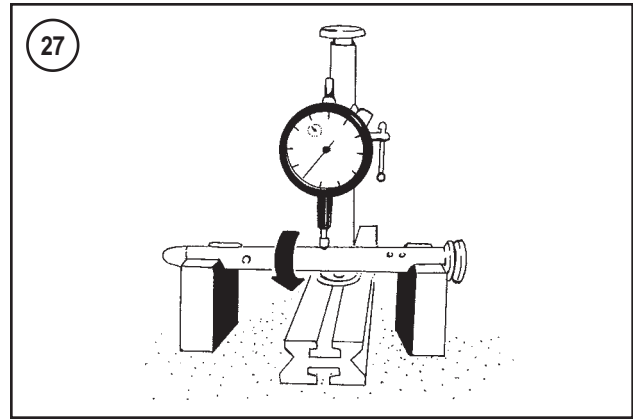

a flat surface, like a plate glass. The manufacturer does not provide service limit specifications for runout.

8. Make sure the oil passage holes in the damper rod (**Figure 28**) are open. If clogged, flush with solvent and dry with compressed air.

9. Check the threads in the bottom of the damper rod for stripping, cross-threading or sealer residue. If necessary, use a tap to renew the threads or to remove any deposits.

10. Check the damper rod rebound spring and the fork spring for wear or damage. The manufacturer does not provide service limit specifications for spring free length.

11. The manufacturer specifies that the oil seals (A, **Figure 29**) should be replaced whenever they are removed. If installing the original oil seals, inspect them closely for wear, hardness or other damage. Always replace both oil seals as a set.

12. Inspect the outer dust seal(s) (B, **Figure 29**) for cracks, weather deterioration or other damage. Replace if damaged.

13. Replace the fork cap O-ring if leaking or damaged.

14. Any parts that are worn or damaged should be replaced. When replacing fork springs, replace both springs as a set; do not replace only one spring. Simply cleaning and reinstalling unserviceable components will not improve performance of the front suspension.

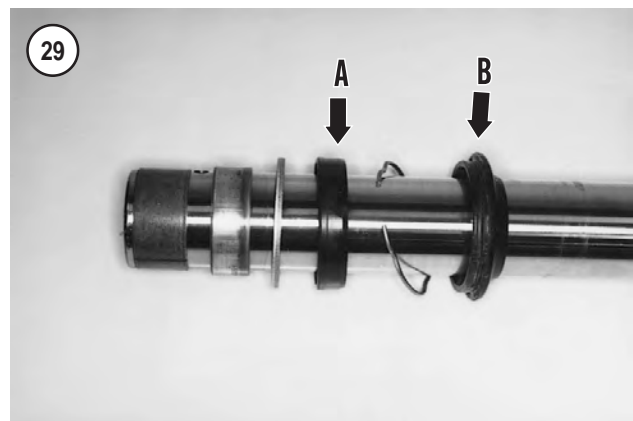

Assembly

Refer to **Figure 10**.

1. Prior to assembly, perform the inspection procedure in this section. Clean all parts before assembly.

2. Coat all parts with the specified fork oil (Chapter Three) before assembly.

3. Install the rebound spring onto the damper rod (**Figure 30**) and slide the rod into the fork tube until it protrudes from the end of the tube.

4. Install the oil lock piece (**Figure 31**) onto the end of the damper rod.

5. Insert the fork spring (**Figure 32**) into the fork tube so that the tapered end of the spring faces toward damper rod. Install the fork cap to tension the spring and hold the damper rod in place.

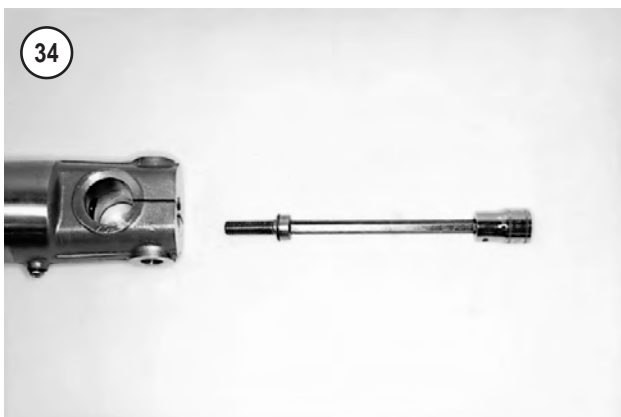
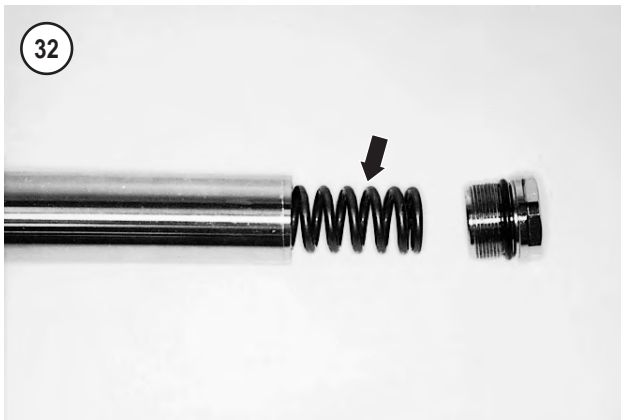
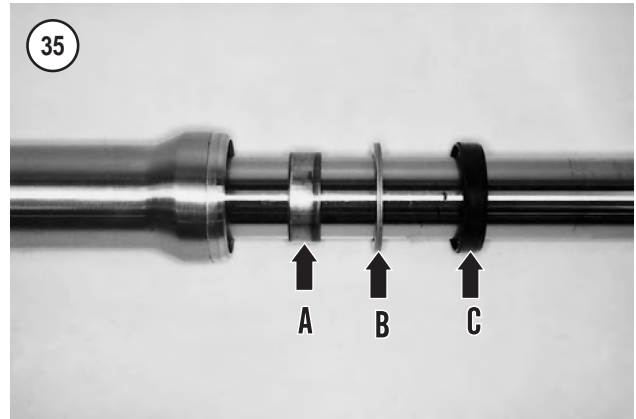

6. Install the slider over the damper rod (**Figure 33**) and onto the fork tube until it bottoms. Make sure the oil lock piece is still mounted onto the end of the damper rod.

7. Install the washer onto the damper rod Allen bolt.

8. Apply a non-permanent thread locking compound to the damper rod Allen bolt threads prior to installation. Insert the bolt (**Figure 34**) through the lower end of the slider and thread it into the damper rod. Tighten the bolt securely.

9. Remove the fork cap and fork spring (**Figure 32**).

NOTE

The slider bushing, seal spacer and oil seal are installed into the slider at the same time with a suitable driver placed over the fork tube and against the oil seal. A fork seal driver (part No. HD-36583 or equivalent) can be used. A piece of pipe can also be used to drive the parts into the slider. When using a piece of pipe or similar tool, do not damage to the slider, oil seal or fork tube. Wrap both ends of the pipe or tool with duct tape to prevent it from scratching the fork tube and tearing the oil seal.

10. Install the slider bushing, seal spacer and oil seal (**Figure 35**) at the same time. Perform the following:

- a. Coat the slider bushing (A, **Figure 35**) with fork oil and slide the bushing down the fork tube and rest it against the slider bore.
- b. Install the seal spacer (B, **Figure 35**) over the fork tube with the concave side facing down. Rest the seal spacer on the slider bushing.
- c. Slide a new oil seal (C, **Figure 35**) over the fork tube with the closed side facing up. Rest the oil seal on the seal spacer.
- d. Slide the fork seal driver down the fork tube (**Figure 36**).
- e. Drive the bushing, seal spacer and oil seal into the slider until the retaining ring groove in the slider can be seen above the top surface of the oil seal.
- f. Remove the fork seal driver.

11. Install the retaining ring (**Figure 37**) into the slider groove. Make sure the retaining ring is fully seated in the groove.
12. Slide the dust seal (**Figure 38**) down the fork tube and seat it into the top of the slider.
13. Install the dust cover (**Figure 39**) as follows:
 - a. Slide the dust cover down the fork tube and rest it against the top of the slider.
 - b. Slide one of the discarded oil seals down the fork tube and rest it against the dust cover.
 - c. Use the same fork seal driver used in Step 10 and carefully drive the dust cover onto the top of the slider as shown in **Figure 39**.
 - d. Remove the installation tool and old oil seal.
14. Fill the fork tube with the correct quantity of Type E Fork Oil or equivalent listed in **Table 1**.
15. The fork spring is tapered at one end. Install the spring (**Figure 32**) so that the tapered end faces toward the bottom of the fork.
16. Lubricate the fork cap O-ring and threads with new fork oil.
17. On 1988-2003 models, align the fork cap with the spring (**Figure 32**) and push down on the cap to compress the spring. Start the cap slowly, don't cross thread it. Place the slider in a vise with soft jaws and tighten the fork cap securely.
18. Install the fork tube as described in this chapter.
19. Install the fork cap on 1986-1987 models after fork installation.

FRONT FORK (1200S MODELS)

The front suspension consists of a spring-controlled, hydraulically dampened telescopic fork.

Before suspecting major trouble, drain the front fork oil and refill with the proper type and quantity (Chapter Three). If the trouble persists, such as poor damping, a tendency to bottom or top out, or leaks around the seals, follow the service procedures in this section.

To simplify fork service and to prevent the mixing of parts, remove, service and install the legs individually.

Front Fork Adjustment

Suspension preload adjustment

Adjust the front and rear spring preload before making any other suspension adjustments. An assistant is required to determine proper preload adjustment for a particular load on the motorcycle.

1. Remove the motorcycle from the sidestand, then bounce the suspension several times to make sure nothing is binding.
2. With the motorcycle unloaded, measure the rear suspension length and the front suspension length.



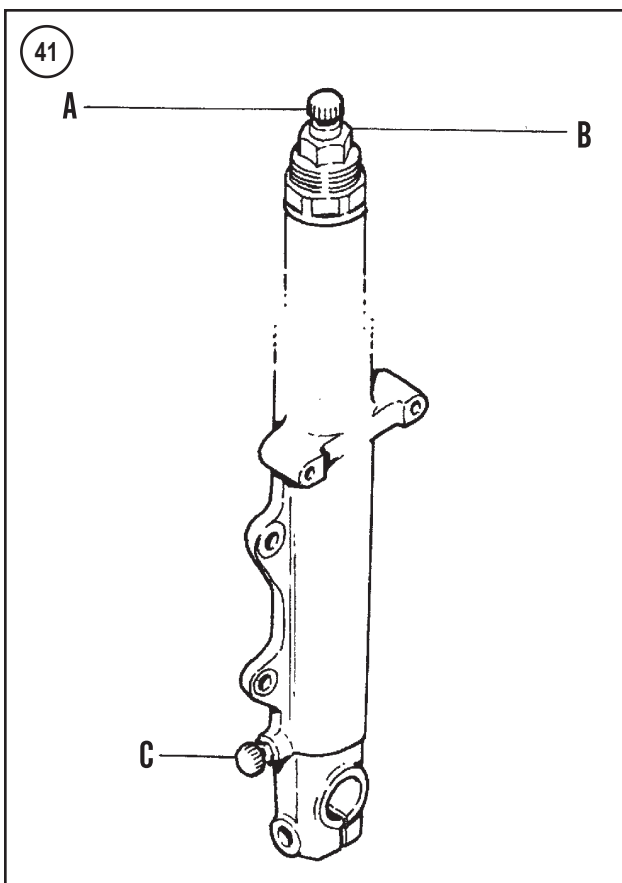
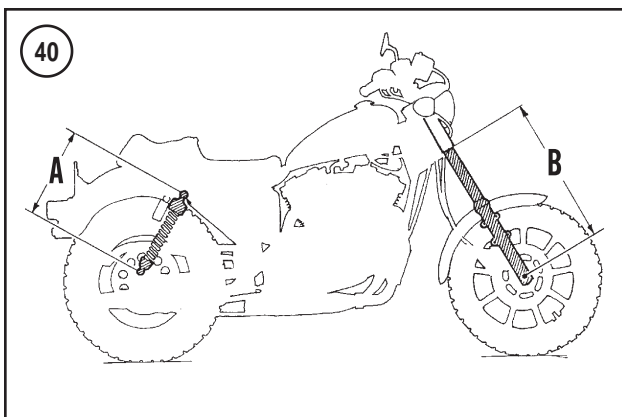

- a. The rear suspension length is the distance from the center of the upper shock nut to the center of the lower shock nut (A, **Figure 40**).
 - b. The front suspension length is the distance from the center of the front axle to the bottom of the lower triple clamp (B, **Figure 40**).
3. Load the full gear onto the motorcycle.
 4. Measure the rear-suspension length and front-suspension length of the loaded motorcycle.

WARNING

Preload must be equal on both sides of the motorcycle. Set both rear shock-absorber preload cams to the same setting. Also set

both fork adjusting nuts to the same setting. Handling will be adversely affected if preload is not the same on both sides of the motorcycle.

5. Subtract the loaded suspension length from the unloaded suspension length. The difference must be 0.5-1.0 inches (12.7-25.4 mm). Adjust the preload if the difference is not within the specification.

- a. To adjust the front preload, turn the preload adjuster (A, **Figure 41**) with a 7/8-in. wrench. Turning the nut clockwise increases front preload; counterclockwise decreases the preload.
- b. To adjust the rear preload, refer to *Shock Absorber* in Chapter Fifteen.

Front fork damping adjustment

The 1200S fork is adjustable for compression and rebound damping.

1. Adjust the preload as described in the *Suspension Preload Adjustment* in this section.

WARNING

Compression and rebound damping settings must be equal on both sides of the motorcycle. Handling will be adversely affected if damping is not the same on both fork legs.

2. The front fork on the 1200S has 14 compression damping settings. Setting 1 (fully clockwise) is the hardest; setting 14 (fully counterclockwise) is the softest. The recommended setting is 13 clicks from the hardest setting.

NOTE

To ensure the desired results, do not adjust the damping more than two clicks without testing the setting.

- a. Turn the compression damping adjuster (B, **Figure 41**) one or two clicks. Turning the adjuster clockwise increases compression damping, counterclockwise decreases compression damping.
 - b. Turn the compression damping adjuster on the other fork leg to the same setting.
 - c. Test ride the motorcycle.
 - d. Repeat the above steps until the desired compression damping is obtained.
3. The 1200S front fork has 15 rebound damping settings. Setting 1 (fully clockwise) is the hardest; setting 15 (fully counterclockwise) is the softest. The recommended setting is 8 clicks from the hardest setting.
 - a. Turn the rebound damping adjuster (C, **Figure 41**) one or two clicks. Turning the rebound adjuster clockwise increases rebound damping; counterclockwise decreases rebound damping.
 - b. Turn the rebound damping adjuster on the other fork leg to the same setting.

- c. Test ride the motorcycle.
- d. Repeat the above steps until the desired rebound damping is obtained.

Removal

Refer to **Figure 42**.

1. Support the motorcycle so the front wheel clears the ground. Make sure the motorcycle is stable before removing the front wheel and fork legs.
2. Remove the front wheel (Chapter Thirteen).
3. Remove the front fender (Chapter Seventeen).

NOTE

Label the left and right fork legs so they can be reinstalled in their original positions.

4. Loosen the upper fork bracket pinch bolt.
5. If the fork legs are going to be disassembled, loosen but do not remove the fork cap.
6. Loosen the lower fork-bracket pinch bolt, and slide the fork leg out of the fork brackets. If necessary, rotate the fork leg while removing it.
7. If fork service is required, refer to *Disassembly* in this section.

Installation

1. Clean any corrosion or dirt from the upper and lower fork-bracket receptacles.

NOTE

The fork assemblies must be reinstalled on the correct side of the motorcycle so the brake caliper and front fender can be properly installed.

2. Install each fork leg so that the tube extends 1.735-1.745 in. (44.1-44.3 mm) above the upper fork bracket as shown in **Figure 43**.
3. Tighten the lower bracket pinch bolt to 30 ft.-lb. (41 N•m).
4. Tighten the upper bracket pinch bolt to 30 ft.-lb. (47 N•m).
5. Install the front fender (Chapter Seventeen).
6. Install the front wheel (Chapter Thirteen).
7. Apply the front brake and pump the front fork several times to seat the fork and front wheel.

Disassembly

To simplify fork service and to prevent the mixing of parts, the legs should be disassembled and assembled individually.

Refer to **Figure 42**.

NOTE

Fork holding tools are available (Figure 11, typical), and such a tool may be shown in the

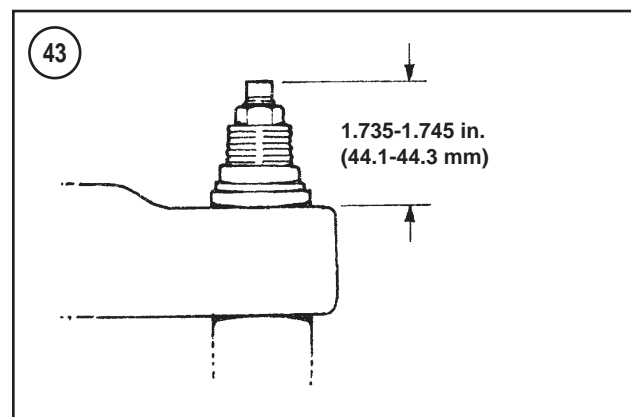
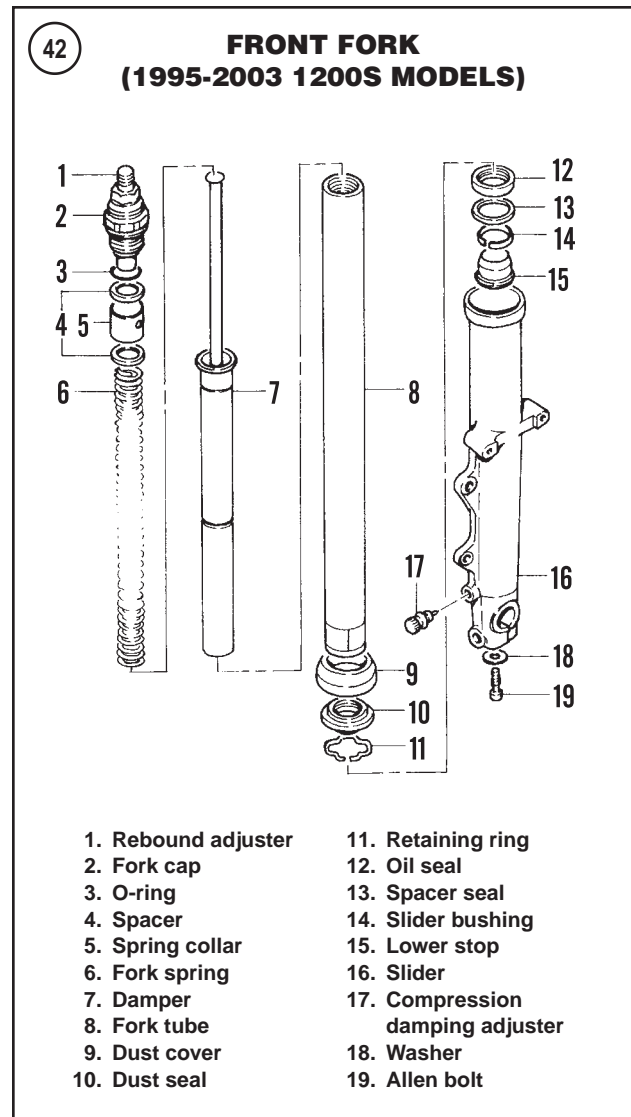

following illustrations. However, the text refers to the use of a vise as a holding tool.

1. Clamp the fork axle boss at the bottom of the slider in a vise with soft jaws. Do not clamp the slider at any point above the fork axle boss.

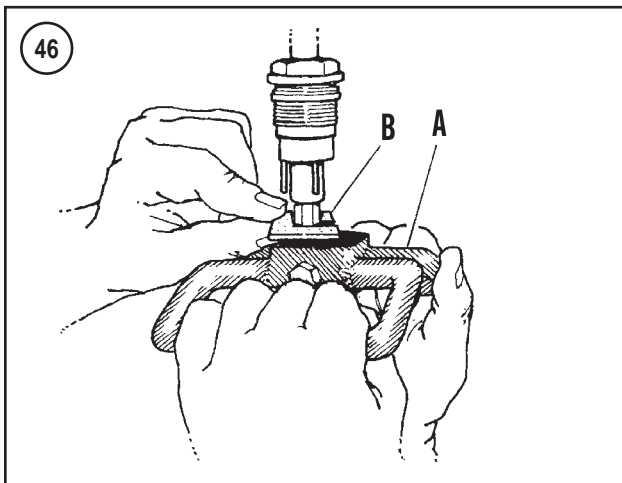
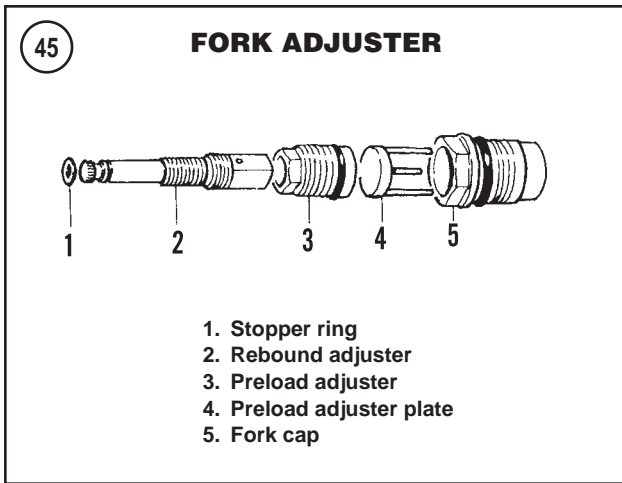

NOTE

Loosen the bottom Allen bolt before removing the fork cap and spring. Leaving the cap on provides spring tension against the damper rod. This prevents the damper rod from spinning while attempting to loosen the Allen bolt.

2. Loosen, but do not remove, the Allen bolt at the bottom of the slider (**Figure 44**).

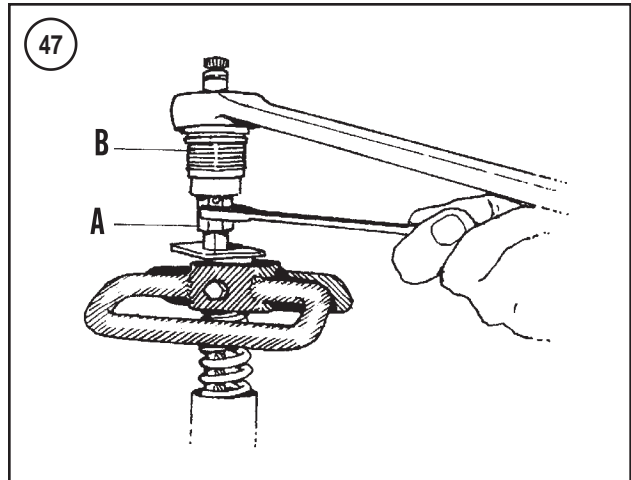

NOTE

Do not remove the rebound adjuster (2, **Figure 45**) from the damper rod. If it is removed, the adjuster will have to be reset during assembly.

3. Remove the stopper ring (1, **Figure 45**), and remove the spring preload adjuster (3, **Figure 45**).

WARNING

Stay clear of the fork cap when removing it. The fork cap is under spring pressure, and it may fly off when loosened. In addition, make sure the fork tube is fully extended from the slider. If the fork tube is damaged and stuck in a compressed state, have a dealership disassemble the fork.

4. Unscrew the fork cap from the fork tube. The fork leg will fall away from the cap.

5. Install the fork spring compressor (A, **Figure 46**; part No. HD-41549A) onto the spring collar. Tighten the screws on the compressor so they engage the holes in the spring collar.

6. Use the tool to compress the spring and have an assistant insert the fork spring plate tool (B, **Figure 46**; part No. HD-41551) between the upper spacer and the spring collar.

7. Hold the rebound adjuster (A, **Figure 47**) and remove the fork cap (B) from the adjuster.

8. Remove the spring plate tool and fork spring compressor.

9. Remove the spacers, spring collar and fork spring from the fork tube.

10. Remove the slider from the vise. Pour out the oil by pumping the damper rod until the rod moves freely. Check the oil for contamination, which indicates worn or damaged parts. Discard the oil after examining it.

11. Remove the Allen screw and washer (**Figure 48**) at the bottom of the slider.

12. Insert a small flat-tipped screwdriver under the dust cover (9, **Figure 42**), and pry the cover out of the slider. Do

not damage the slider surface. Remove the cover from the slider.

13. Insert a small flat-tipped screwdriver under the dust seal (**Figure 49**). Pry the seal out of the slider and remove it. Do not damage the slider surface.

14. Pry the retaining ring out of the groove in the slider and remove it. See **Figure 50**.

NOTE

The slider bushing is installed with an interference fit. When separating the fork tube and slider, the slider bushing, spacer seal and oil seal will be removed at the same time.

15. Hold the fork tube and pull the slider downward repeatedly so the slider bushing knocks against the fork tube bushing (**Figure 51**). As the slider bushing is knocked out of the slider, it pushes the oil seal and seal spacer out of the slider. Continue until these components are removed from the slider.

Inspection

CAUTION

*Clean and handle the guide bushings (**Figure 52**) carefully to avoid damaging their coating material. If there is any metal powder clinging to the guide bushings, clean them with new fork oil and a nylon brush.*

1. Initially clean all of the fork components in solvent. Make sure any cleaning solvents used will not damage the rubber parts. Then, clean all components with soap and water, and rinse them with clear water. Dry thoroughly.

2. Check the fork tube (A, **Figure 53**) for bending, nicks, rust or other damage. Check the fork tube runout with a set of V-blocks and a dial indicator. Replace the fork tube if runout exceeds 0.008 in. (0.2 mm).

3. Check the slider (B, **Figure 53**) for dents or other exterior damage. Check the retaining ring groove (**Figure 54**) in the top of the slider for cracks or other damage. Replace the slider if the groove is cracked or damaged.

4. Check the slider and fork tube bushings (**Figure 52**) for severe wear, cracks or damage. The slider bushing was removed with the oil seal. The fork tube bushing should not be removed unless it is going to be replaced. To replace the fork tube bushing, perform the following:

- Expand the bushing slit (**Figure 55**) using a screwdriver and slide the bushing off the fork tube.
- Coat the new bushing with new fork oil.
- Install the new bushing by expanding the slit using a screwdriver. Expand the bushing only enough to fit it over the fork tube.
- Seat the new bushing into the groove in the fork tube.

5. Replace the Allen bolt and washer if damaged.
6. Make sure the oil passage holes in the damper are open. If clogged, flush with solvent and dry with compressed air.

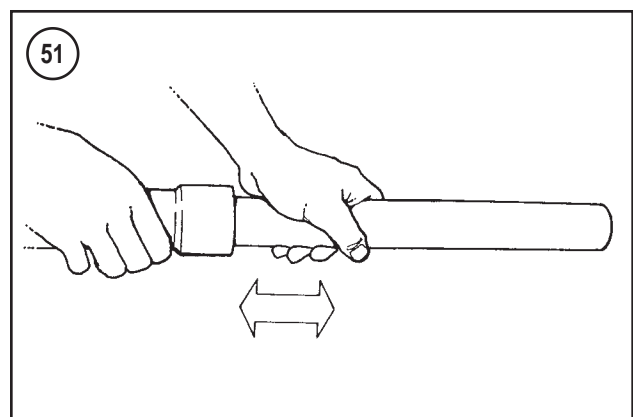
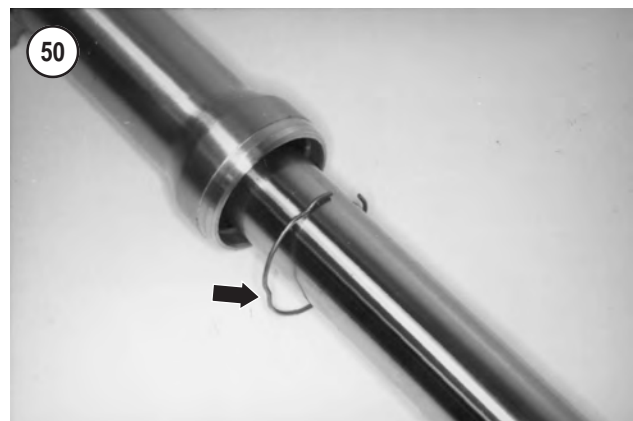
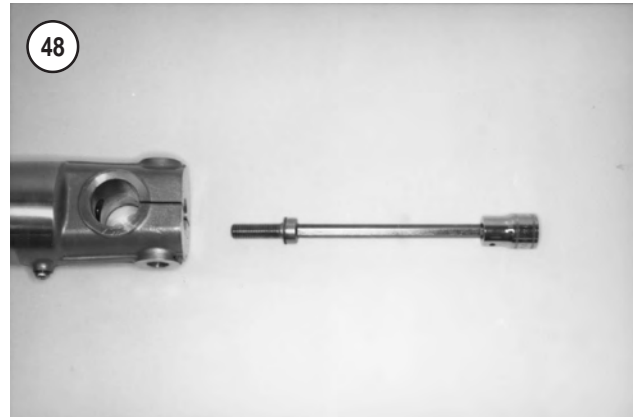

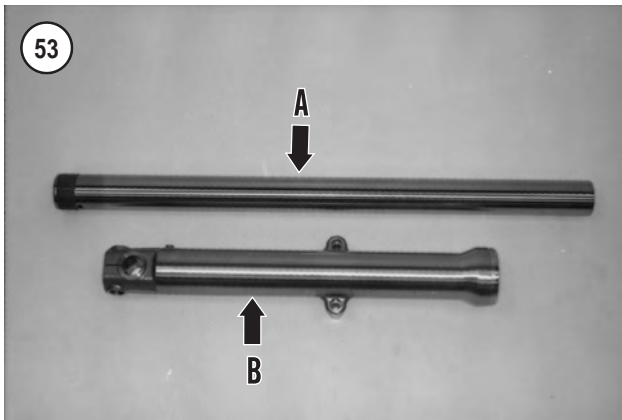
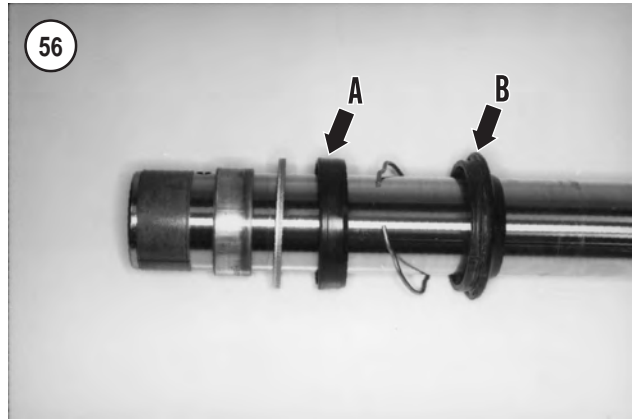

7. Check the threads in the bottom of the damper for stripping, cross-threading or sealer residue. If necessary, use a tap to renew the threads or to remove any deposits.
8. Check the fork spring free length. Replace the fork spring if the free length is less than 16.02 in. (407 mm).
9. Inspect the outer dust seal(s) (B, **Figure 56**) for cracks, weather deterioration or other damage. Damaged dust seals allow dirt to pass through and damage the oil seal.
10. Replace the fork cap O-ring if leaking or if severe wear or damage is apparent.
11. Replace any worn or damaged parts.
12. When replacing fork springs, replace the springs as a set.

Assembly

Refer to **Figure 42**.

1. Prior to assembly, perform the inspection procedure in this section to confirm all worn or defective parts have been repaired or replaced. Clean all parts before assembly.
2. Coat all parts with the specified fork oil (Chapter Three) before assembly.
3. Insert the fork tube into the slider.

NOTE

The slider bushing, seal spacer and oil seal are installed into the slider at the same time. Use a fork seal driver (part No. HD-36583 or an equivalent). A piece of pipe can also be used to drive the parts into the slider. When using a piece of pipe or similar tool do not damage the slider, oil seal or fork tube. Wrap both ends of the pipe or tool with duct tape to prevent it from scratching the fork tube and tearing the oil seal.

4. Install the slider bushing, seal spacer and oil seal at the same time. Perform the following:
 - a. Coat the slider bushing (A, **Figure 57**) with fork oil. Slide the bushing down the fork tube and rest it against the slider bore. Make sure the opening in the bushing faces the side, not the front or rear of the slider.

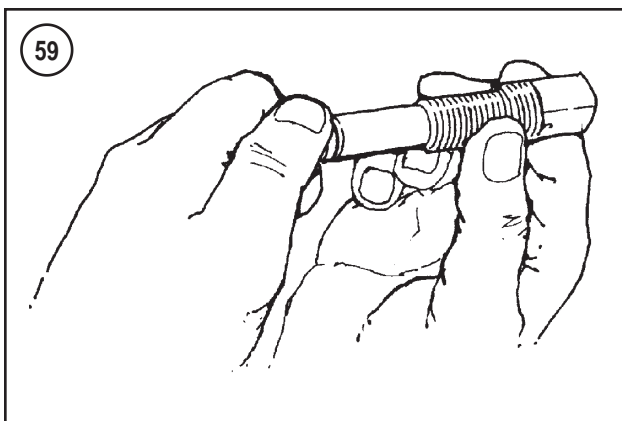
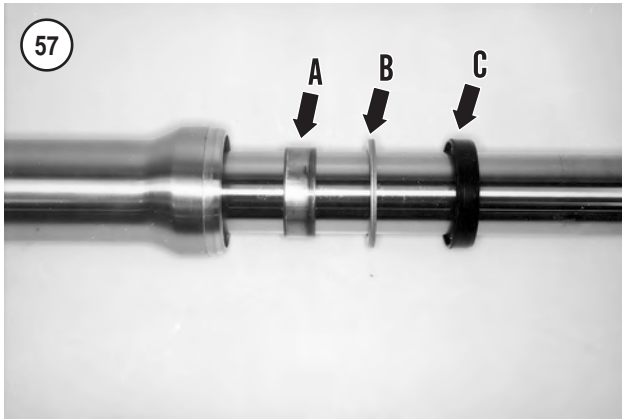

- b. Install the seal spacer (B, **Figure 57**) over the fork tube with the concave side facing down. Rest the seal spacer on the slider bushing.
- c. Slide a new oil seal (C, **Figure 57**) over the fork tube with the closed side facing up. Rest the oil seal on the seal spacer.
- d. Slide the fork seal driver down the fork tube (**Figure 58**).
- e. Drive the bushing, seal spacer and oil seal into the slider until the retaining ring groove in the slider can be seen above the top surface of the oil seal.
- f. Remove the fork seal driver.

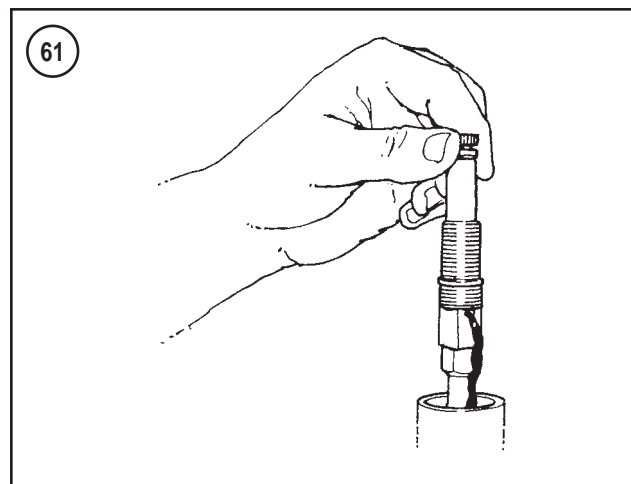
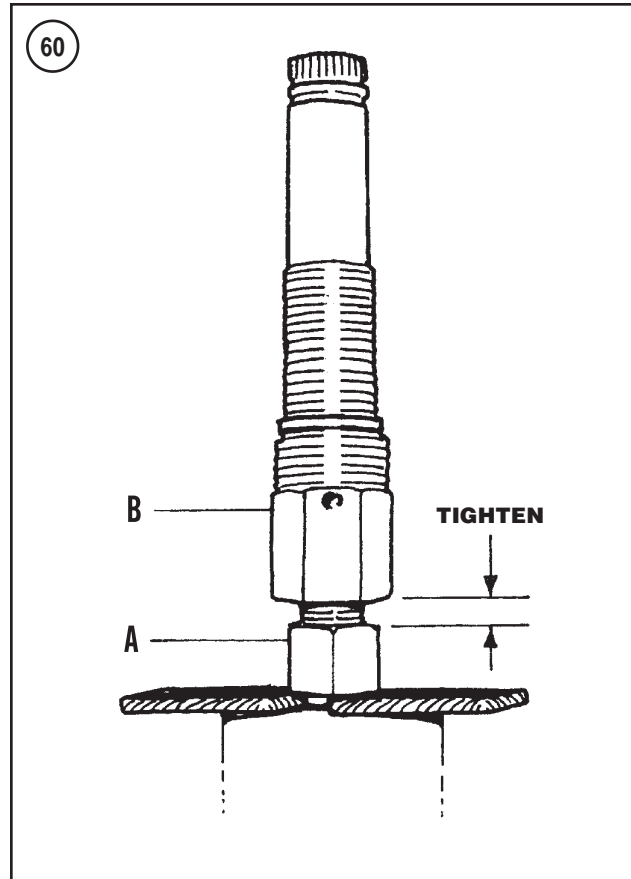

5. Install the retaining ring (**Figure 50**) into the slider groove. Make sure the retaining ring is fully seated in the groove.
6. Slide the dust seal (**Figure 49**) down the fork tube and seat it into the top of the slider.
7. If the rebound adjuster was removed from the damper rod, perform the following:
 - a. Turn the locknut onto the damper rod until the nut bottoms.
 - b. Press the detent spring and ball with your thumb, and turn the rebound adjuster counterclockwise until it

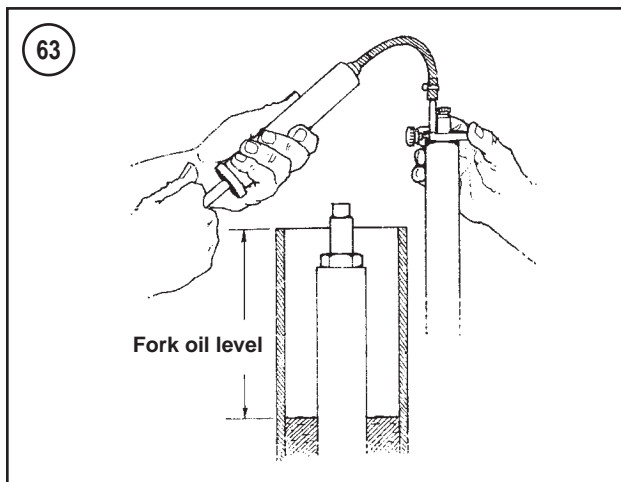
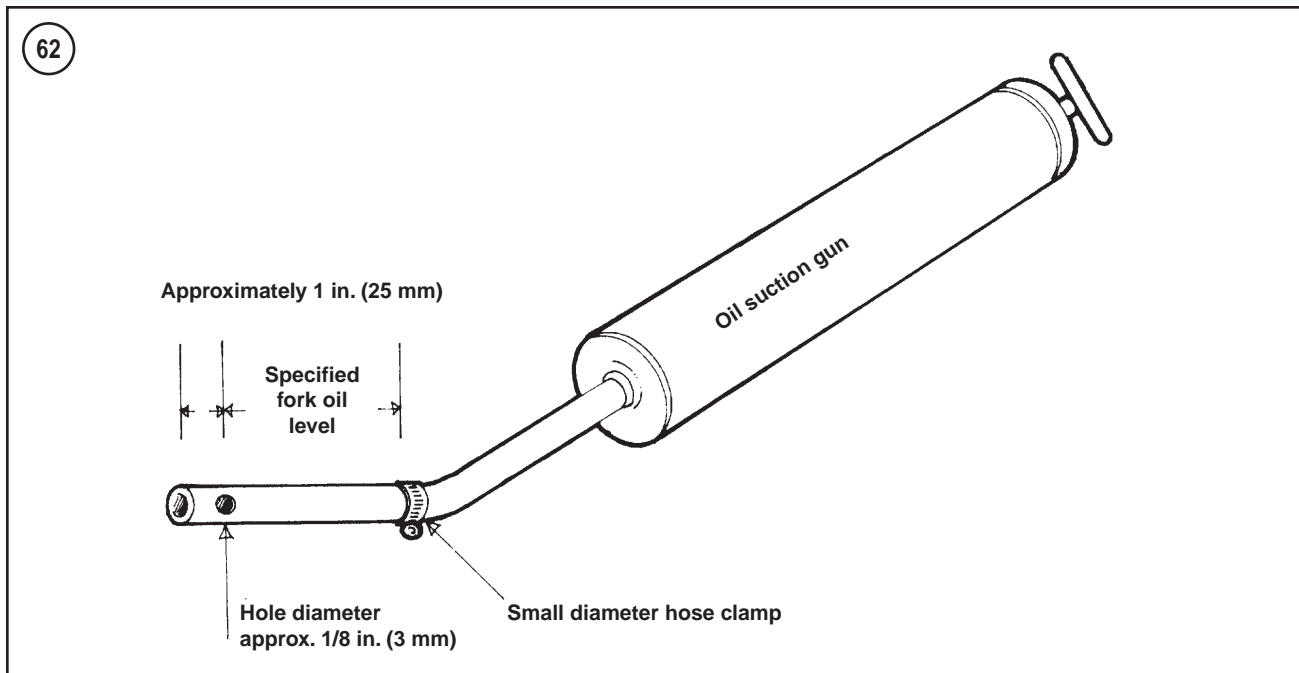

backs out to the last click (**Figure 59**). Turn the rebound adjuster clockwise 13 clicks.

- c. Thread the rebound adjuster onto the damper rod. Turn the rod as far as it will go without forcing it. Do not overtighten the adjuster.
 - d. Thread the locknut (A, **Figure 60**) up into the rebound adjuster until the locknut is seated against the rebound adjuster (B).
8. Clamp the fork axle boss at the bottom of the slider in a vise with soft jaws. Do not clamp the slider at any point above the fork axle boss.
 9. Install the damper into the fork tube.
 10. Install the Allen bolt by performing the following:
 - a. Insert the fork spring into the fork tube so the tightly coiled end goes down into the slider. Install the fork cap to tension the spring and hold the damper in place.

- b. Install the washer onto the damper rod Allen bolt.
- c. Insert the Allen bolt (**Figure 48**) through the lower end of the slider and thread it into the damper. Tighten the bolt to 22-29 ft.-lb. (30-39 N•m).
- d. Remove the fork cap and fork spring.

11. Refer to **Table 1** for the fork oil capacity. Pour half of the quantity into the fork tube. Pump the damper rod slowly to purge air from the slider and fork tube (**Figure 61**). Pump the rod at least ten times.
12. Push the damper rod into the fork tube until it bottoms.
13. Pour the remaining quantity of fork oil into the fork tube.

NOTE

*An oil level-measuring device can be made, as shown in **Figure 62**. Position the lower edge of the hose clamp at the specified oil level distance up from the small diameter hole. Fill the fork with a few ounces more than the required amount of oil. Position the hose clamp on the top edge of the fork tube and draw out the excess oil. Oil is drawn out until the level reaches the small diameter hole. A precise oil level can be achieved with this simple device.*

14. Use an oil gauge (part No. HD-59000A or equivalent) to adjust the oil to the level specified in **Table 1**. See **Figure 63**.
15. Install the fork spring so the end with closer-wound coils faces the slider.
16. Install one spacer, the spring collar, and the other spacer into the fork tube. One side of the spacer has sharper edges than the other one. Make sure the side with the sharp edge faces the spring collar.

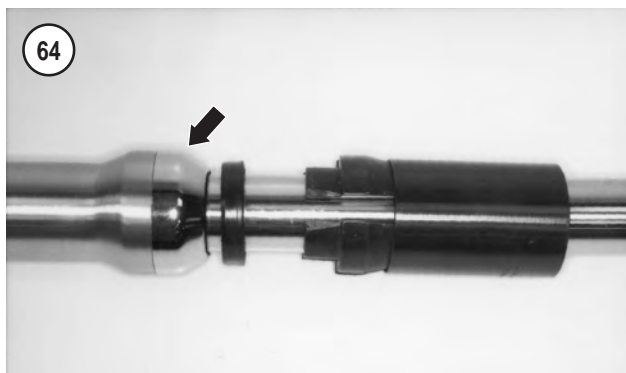

17. Install the fork spring compressor (A, **Figure 46**) onto the spring collar. Tighten the screws on the compressor so they engage the holes on the spring collar.

18. Use the tool to compress the spring and have an assistant install the spring plate (B, **Figure 46**) between the upper spacer and the spring collar.

19. Install the fork cap (B, **Figure 47**) onto the rebound adjuster (A). Tighten the fork cap to 22-29 ft.-lb. (30-39 N•m).

20. Remove the spring plate and fork spring compressor. Turn the fork cap into the fork tube. Tighten the fork cap to 11-22 ft.-lb. (15-30 N•m).

21. Install the preload adjuster plate (4, **Figure 45**).

22. Install a new O-ring onto the preload adjuster (3, **Figure 45**). Lubricate the O-ring with fork oil, and install the preload adjuster.

23. Install the stopper ring.

24. Install the dust cover (**Figure 64**) as follows:

- Slide the dust cover down the fork tube and rest it against the top of the slider.
- Slide one of the discarded oil seals down the fork tube and rest it against the dust cover.
- Use the same fork seal driver used in Step 4 and carefully drive the old dust cover onto the top of the slider as shown in **Figure 64**.
- Remove the driver and old oil seal.

25. Adjust the spring, compression damping and rebound damping (Chapter Three).

STEERING HEAD AND STEM

The fork stem extends from the lower triple clamp into the frame steering head. The lower portion of the steering head rests on a tapered roller bearing located at the bottom of the fork stem. The upper end of the fork stem rides in a tapered roller bearing that seats in the upper portion of the steering head. Both bearings seat against races pressed into the steering head. Dust shields are used at both bearing areas to protect bearings from dust and other contaminants.

Removal

Refer to **Figure 65** or **Figure 66**.

65

STEERING ASSEMBLY (1986-1987 MODELS)

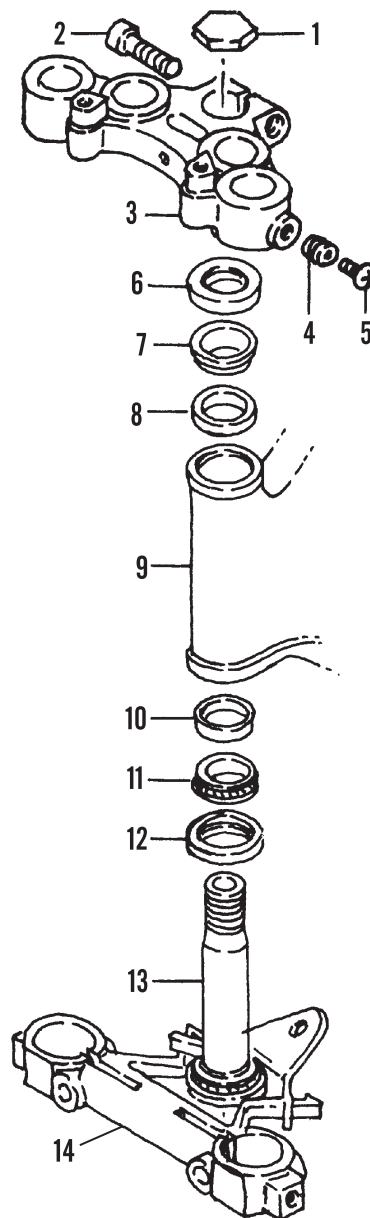

- Nut
- Pinch bolt
- Upper fork bracket
- Screw
- Screw
- Upper bearing shield
- Bearing
- Upper bearing race
- Frame
- Lower bearing race
- Bearing
- Dust shield
- Steering stem and bracket
- Lower fork bracket

66

STEERING ASSEMBLY (1988-2003 MODELS)

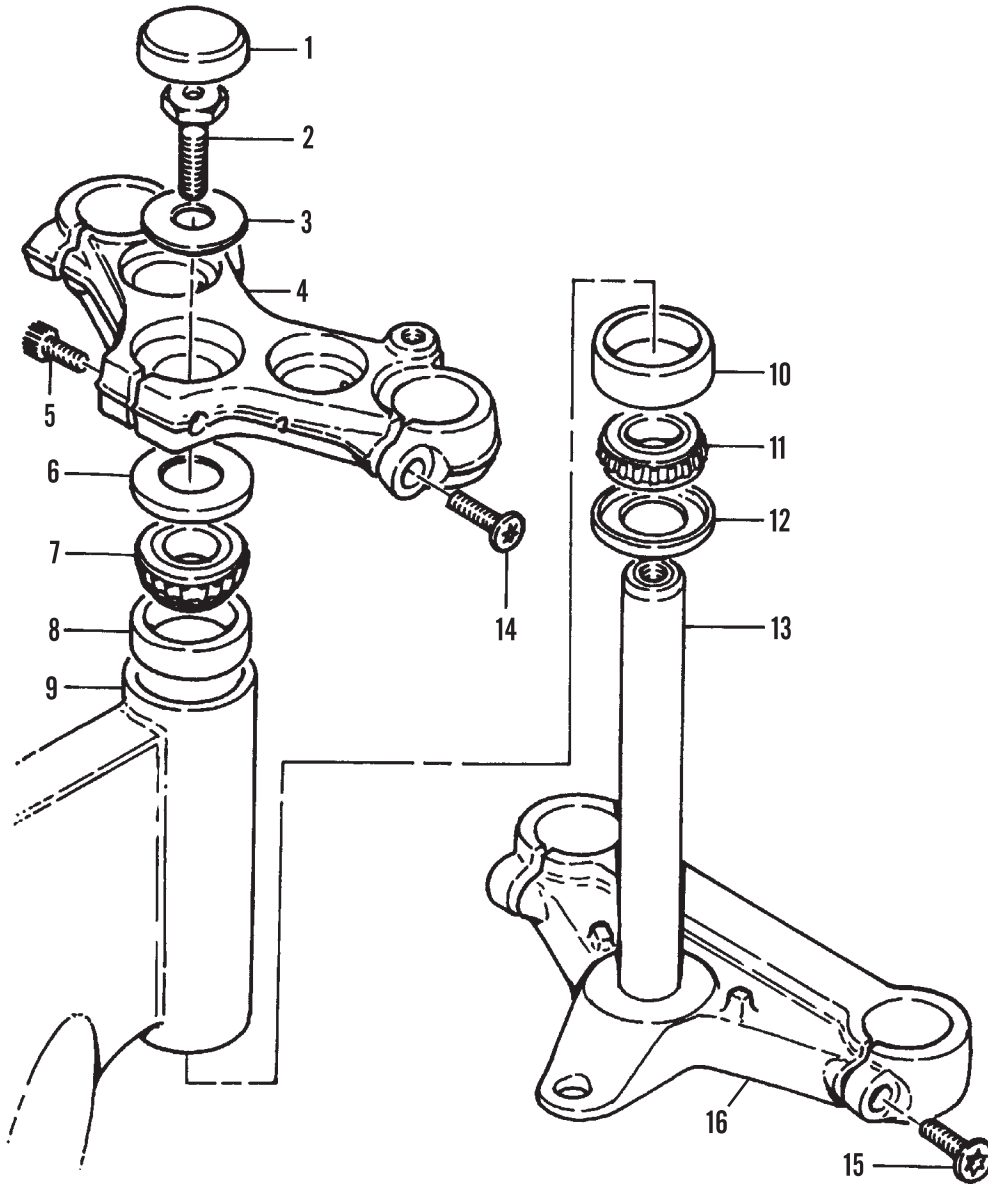

- 1. Cap (1991-2003 models)
- 2. Steering stem bolt
- 3. Washer
- 4. Upper fork bracket
- 5. Pinch bolt
- 6. Dust shield
- 7. Upper bearing
- 8. Upper bearing racer
- 9. Frame neck
- 10. Lower bearing race
- 11. Lower bearing
- 12. Dust shield
- 13. Steering stem/lower fork bracket
- 14. Upper fork tube pinch bolt
- 15. Lower fork tube pinch bolt
- 16. Lower fork bracket

NOTE

Although not necessary, it is advisable to remove the fuel tank as described in Chapter Ten or Chapter Eleven. Otherwise, cover it with suitable material.

1. Remove the headlight (Chapter Twelve).
2. Remove the front fork as described in this chapter.
3. On models so equipped, disconnect the speedometer and tachometer cables from the instruments.
- 4A. On 1998-2003 models, remove the brake hose bracket at the bottom of the fork stem bracket (**Figure 67**). Do not disconnect the brake hose connection.
- 4B. On 1986-1987 models, detach the brake hose bracket on the upper fork bracket. Do not disconnect the brake hose connection.

NOTE

If it is not necessary to remove the handlebar, the handlebar can be removed along with the upper fork bracket. If necessary, remove the handlebar as described in this chapter.

5. On 1991-2003 models, unscrew the bolt cap (**Figure 68**) and remove it. See **Figure 69**.
- 6A. On 1986-1987 models, remove the fork stem end nut (**Figure 70**).
- 6B. Remove the steering stem bolt (A, **Figure 71**) and washer.

NOTE

Make sure the steering stem lower fork bracket to keep it from falling out once the pinch bolt is loosened.

7. Loosen the pinch bolt (B, **Figure 71**) and lift the upper fork bracket (C) off the steering stem. Set the bracket aside with the cables attached.
8. Lower the fork stem assembly out of the steering head and remove it.
9. Remove the upper dust cover (**Figure 72**) and bearing (**Figure 73**).
10. Inspect the fork stem and bearing assembly as described in this chapter.

Inspection

The bearing races (**Figure 74**) are pressed into the steering head. Do not remove the bearing races unless they require replacement.

Use wheel bearing grease to pack bearings and races when performing the following steps.

1. Wipe the bearing races with a solvent soaked rag and then dry with compressed air or a lint-free cloth. Check the races in the steering head for pitting, scratches, galling or severe wear. If any of these conditions exist, replace the races as described in this chapter. If the races are in good condition, wipe each race with grease.



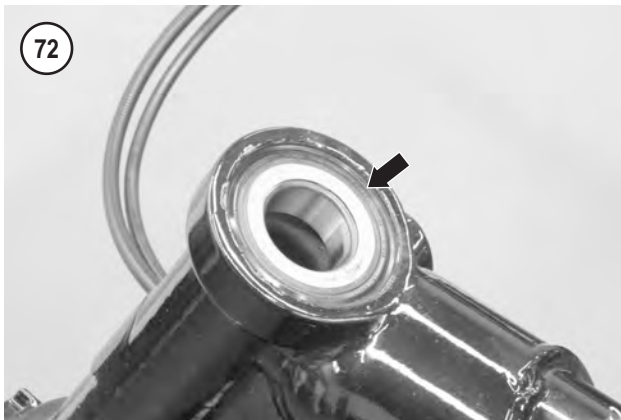
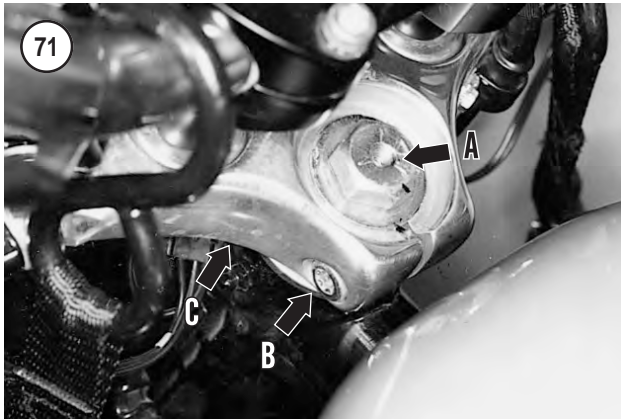

2. Clean the bearings in solvent to remove all of the old grease. Blow the bearing dry with compressed air, making sure not to allow the air jet to spin the bearing. Do not remove the lower bearing from the fork stem unless replacement is required; clean the bearing together with the steering stem.

3. After the bearings are dry, hold the inner race with one hand and turn the outer race with your other hand. Turn the bearing slowly, checking for roughness, looseness, trapped dirt or grit. Check the bearing (**Figure 75**) for pitting, scratches or visible damage. If the bearings are worn, check the dust covers for wear or damage or for improper bearing lubrication. Replace the bearing if necessary. Pack it with grease and wrap it with wax paper until it can be reinstalled. Do not store the bearings for any length of time without lubricating them or they will rust.

4. Check the steering stem for cracks or damage. Check the threads at the top of the stem for stripping or damage. Check the steering stem bolt or nut by threading it into the steering stem; make sure the bolt or nut threads easily with no roughness. If necessary, clean the threads carefully with a brush and solvent or use a tap or die of the correct thread type and size.

5. Worn or damaged parts should be replaced. When discarding a bearing, both bearings and their races should be replaced at the same time. Replace bearing races as described in this chapter.

6. Replace the lower steering stem bearing and dust cover as described in this chapter.

7. Check for broken welds on the frame around the steering head. If any are found, have them repaired by a frame shop.

Installation

1. Make sure the steering head bearing races are properly seated as described in *Steering Head Bearing* in this chapter.

2. Wipe the bearing races with a clean lint-free cloth. Then lubricate each race with bearing grease.

3. Pack the upper and lower bearings with bearing grease. The lower bearing and lower dust shield should be installed on the steering stem prior to installing the steering stem in the steering head. If necessary, install the lower bearing as described in this chapter.

4. Insert the steering stem into the frame steering head and hold it firmly in place.
5. Install the upper bearing around the fork stem and seat it into the upper race. Install the upper dust shield.
6. Install the upper fork bracket (C, **Figure 71**) over the steering stem.
7. Install the washer and the steering stem bolt (A, **Figure 71**). Tighten the bolt hand-tight only.
8. Install the front fork as described in this chapter.
9. Tighten the steering stem bolt (A, **Figure 71**) until the steering stem can be turned from side to side with no noticeable axial or lateral bearing play. When the play feels correct, tighten the fork stem pinch bolt (B, **Figure 71**) securely on 1986-1987 models or to 30 ft.-lb. (41 N•m) on 1988-2003 models.

CAUTION

Do not overtighten the steering stem bolt or the bearings and races may be damaged. Final adjustment of the fork stem will take place after the front wheel has been installed on the motorcycle.

10. Install the brake hose bracket onto the lower fork bracket and tighten the mounting bolt (**Figure 67**) securely.
11. Install the front wheel (Chapter Thirteen).
12. Adjust the steering play as described in *Steering Play Adjustment* in this chapter.

STEERING HEAD BEARING

Whenever the steering stem and bearings are removed from the steering head, cover the steering head with a cloth to protect the bearing races from accidental damage. If a race is damaged, the bearing and race must be replaced as a set. Because the bearing races are pressed into place, do not remove them unless they require replacement.

Upper and Lower Bearing Race Replacement

The upper and lower bearing races (**Figure 74**) are pressed into the frame steering head. Both races are identical and can be purchased separately from the bearing. If bearing replacement is required, purchase the bearing and race as a set.

1. To remove a race, insert an aluminum or brass rod into the steering head and carefully tap the race out from the inside (**Figure 76**). Tap around the race so that neither the race nor the steering head are bent.
2. Clean the steering head with solvent and dry thoroughly.
- 3A. The bearing races can be installed using a head bearing race installation tool (part No. HD-39302 or equivalent). Follow the manufacturer's instructions for using the tool.
- 3B. If a head bearing race installation tool is not available, install the bearing races as follows:
 - a. Clean the race thoroughly before installing it.

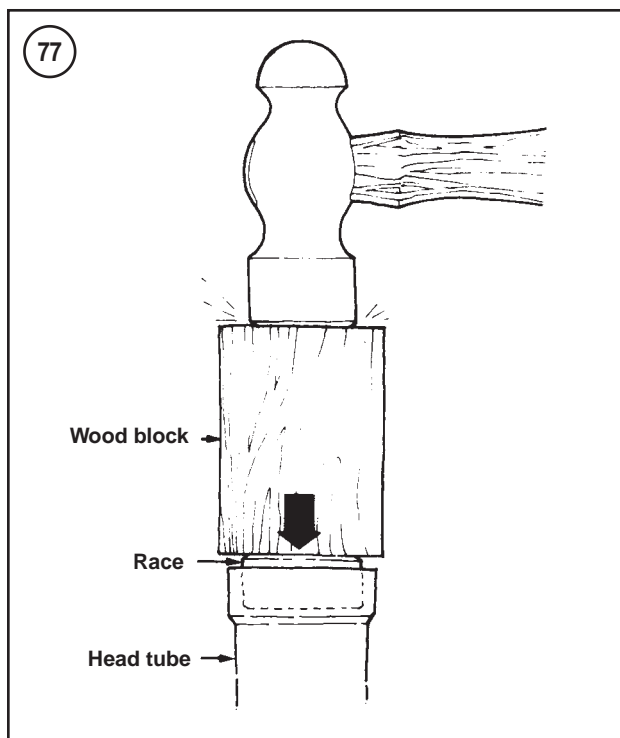
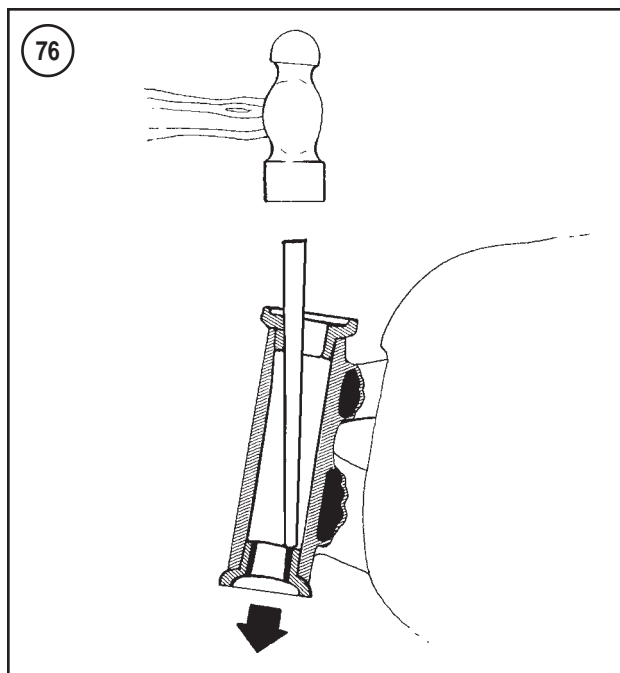

- b. Align the upper race with the frame steering head and tap it slowly and squarely in place with a block of wood, a suitable socket or bearing driver, making sure not to contact the bearing race tapered surface. See **Figure 77**. If an old race is available, grind its outside rim so that it is a slip fit in the steering head, then use it to drive the new race into place. Drive the race into the steering head until it bottoms on the bore shoulder.
- c. Repeat to install the lower race into the steering head.

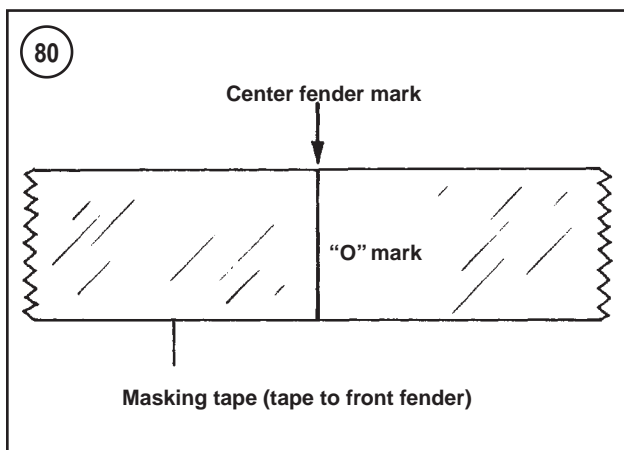
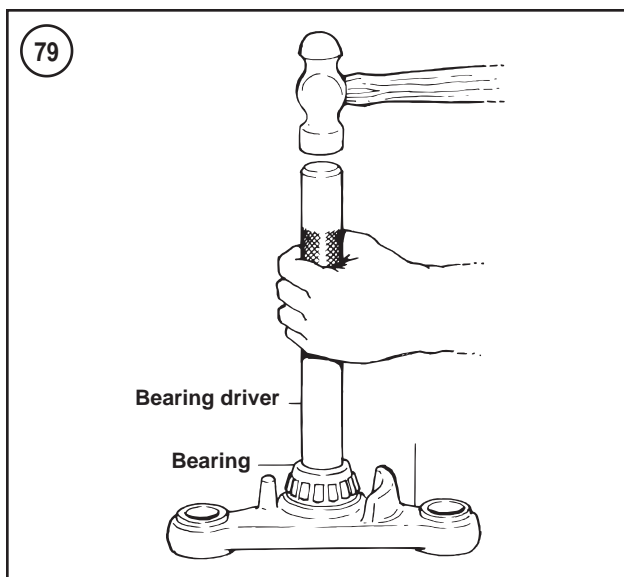

4. Lubricate the bearing races with wheel bearing grease.

Fork Stem Lower Bearing Replacement

Do not remove the fork stem lower bearing (**Figure 78**, typical) unless it is going to be replaced with a new bearing. Do not reinstall a lower bearing that has been removed, as it

is no longer true to alignment. When replacing the lower bearing, install a new lower dust shield.

WARNING

Safety glasses and insulated gloves must be worn when removing the inner race.

1. Using a chisel, break the bearing cage and rollers from the inner race. When the bearing cage and rollers are free, the inner race on the fork stem is exposed. To remove the inner race, heat the race with a torch until it expands enough to slide or drop off the fork stem. Remove and discard the dust cover after removing the bearing.
2. Clean the fork stem with solvent and dry thoroughly.
3. Pack the new bearing with grease before installing it.
4. Slide a new dust shield onto the fork stem so it bottoms on the lower bracket.
5. Align the new bearing with the fork stem and press or drive it onto the fork stem until it bottoms. When installing the bearing onto the fork stem, a bearing driver must be used against the inner bearing race (**Figure 79**). Do not install the bearing by driving against the outer bearing race.

STEERING PLAY ADJUSTMENT

The steering play should be checked periodically and anytime the steering stem assembly has been removed and installed.

1. Support the motorcycle so that the front wheel clears the ground.
2. Remove the windshield, if used, and all other accessory weight from the handlebar and front forks. If any control cable affects handlebar movement, disconnect it.
3. Apply a strip of masking tape across the front end of the front fender. Draw a vertical line across the tape at the center of the fender. Then draw two lines on each side of the centerline, 1 inch apart from each other. See **Figure 80**.
4. Turn the handlebar so that the front wheel points straight ahead.
5. Place a pointer on a stand and then center the pointer so that its tip points to the center of the fender (tape mark) when the wheel points straight ahead.
6. Lightly push the fender towards the right side until the front end starts to turn by itself. Mark this point on the tape.
7. Repeat Step 6 for the left side.
8. Measure the distance between the two marks on the tape. For proper bearing adjustment, the distance should be 1-2 in. (25.4-50.8 mm). If the distance is incorrect, perform Step 9.
9. Adjust steering play as follows:
 - a. Loosen the lower fork tube pinch bolts (**Figure 81**).
 - b. On 1991-2003 models, unscrew and remove the bolt cap (**Figure 69**).
 - c. Loosen the fork stem pinch bolt (A, **Figure 82**).
 - d. If the distance between the two marks is less than 1 in. (25.4 mm), tighten the steering stem nut (**Figure 70**) or bolt (B, **Figure 82**).

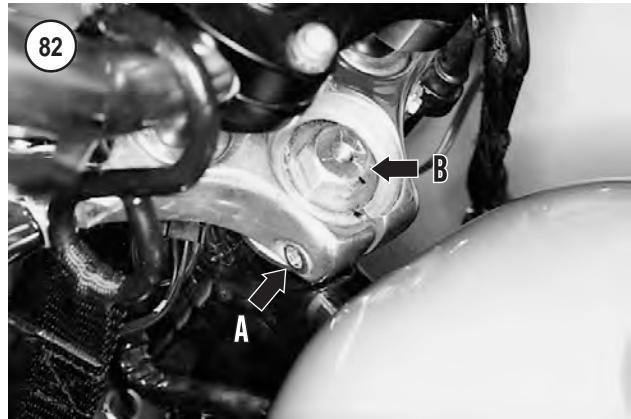

- e. If the distance between the two marks is more than 2 in. (50.8 mm), loosen the steering stem nut (**Figure 70**) or bolt (**Figure 82**).
 - f. Repeat Steps 6 and 7 to measure steering play, continue until the distance between the two marks is within 1-2 in. (25.4-50.8 mm).
10. When steering play adjustment is correct, perform the following:
- a. Tighten the fork stem pinch bolt (**A, Figure 82**) securely on 1986-1987 models or to 30 ft.-lb. (41 N•m) on 1988-2003 models.
 - b. Tighten the lower bracket pinch bolt (**Figure 81**) to 30 ft.-lb. (41 N•m).
 - c. On 1991-2003 models, install and tighten the bolt cap (**Figure 69**) securely.
11. Reinstall all parts previously removed.

Table 1 FRONT FORK OIL* CAPACITY

| | Wet | | Dry | |
|------------------|------|-----|------|-----|
| | oz. | ml | oz. | ml |
| 1986-1987 models | 5.4 | 160 | 6.4 | 189 |
| 1988-1991 models | 9.0 | 266 | 10.2 | 302 |
| 1992-1998 models | | | | |
| 883H models | 10.7 | 316 | 12.1 | 358 |
| All other models | 9.0 | 266 | 10.2 | 302 |
| 1999-2003 models | 9.0 | 266 | 10.2 | 302 |

*Harley-Davidson Type E or equivalent.

Table 2 FRONT FORK SPECIFICATIONS (XL1200S MODELS)

| | in. | mm |
|---|-------|-----|
| Fork tube runout | 0.008 | 0.2 |
| Fork spring free length | 16.02 | 407 |
| Fork oil level (below top of fork tube) | 5.6 | 142 |

Table 3 FRONT SUSPENSION TORQUE SPECIFICATIONS

| | ft.-lb. | in.-lb. | N•m |
|---|---------|---------|-------|
| Brake hose clamp screws | – | 30-40 | 3-5 |
| Fork cap to rebound adjuster (1200S models) | 22-29 | – | 30-39 |
| Fork cap to fork tube (1200S models)* | 11-22 | – | 15-30 |
| Fork lower bracket pinch bolt | 30 | – | 41 |
| Fork slider Allen bolt (1200S models) | 22-29 | – | 30-39 |

(continued)

Table 3 FRONT SUSPENSION TORQUE SPECIFICATIONS (continued)

| | ft.-lb. | in.-lb. | N•m |
|---|----------------|----------------|------------|
| Fork stem pinch bolt (1988-2003 models) | 30 | – | 41 |
| Fork upper bracket pinch bolt 1986-1987 models | 21-27 | – | 29-37 |
| 1988-2003 models | 30 | – | 41 |
| Handlebar clamp bolts | – | 144-180 | 16-20 |
| *Other models no specification available. | | | |

CHAPTER FIFTEEN

REAR SUSPENSION

This chapter covers the rear suspension. Refer to Chapter Thirteen for rear wheel, hub, rear axle and tire service information.

Tables 1 are located at the end of this chapter.

WARNING

Replace all rear suspension fasteners with parts of the same type. Do not use a replacement part of lesser quality or substitute design, as this may affect the performance of the system or result in failure of the part, leading to loss of motorcycle control. Use the torque specifications listed during installation to ensure proper component retention.

SHOCK ABSORBERS

The rear shocks are spring controlled and hydraulically damped. Spring preload can be adjusted on all models.

Spring Preload Adjustment

NOTE

*On 1200S models, both the front and rear suspension spring preload is adjustable. Refer to **Front Fork (1200S Models)** in Chapter*

Fourteen for the spring preload adjustment procedure.

On all models, the shock absorber springs can be adjusted to suit rider and load. Rotate the cam ring (**Figure 1**) at the base of the spring to compress the spring for heavier loads or extend the spring for lighter loads. Use a spanner wrench to rotate the cam ring.

Damping Adjustment

The 1200S model rear shock absorbers are adjustable for compression and rebound damping.

WARNING

Compression and rebound damping settings must be equal on both sides of the motorcycle. Handling will be adversely affected if damping is not the same on both shocks.

1. Adjust the suspension preload as described in *Front Fork (1200S Models)* in Chapter Fourteen.
2. The shock absorbers on the 1200S models have 14 compression damping settings. Setting 1 (fully clockwise) is the hardest; setting 14 (fully counterclockwise) the softest. The

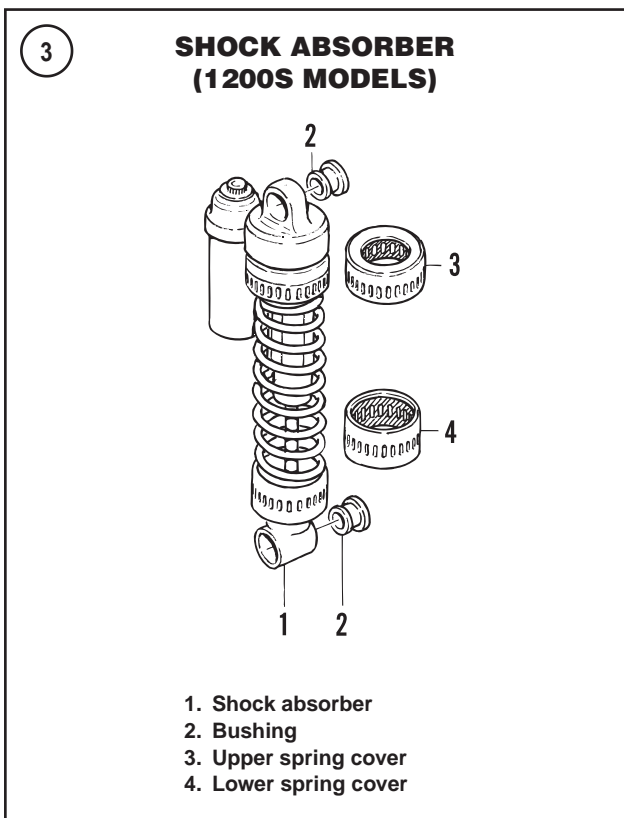
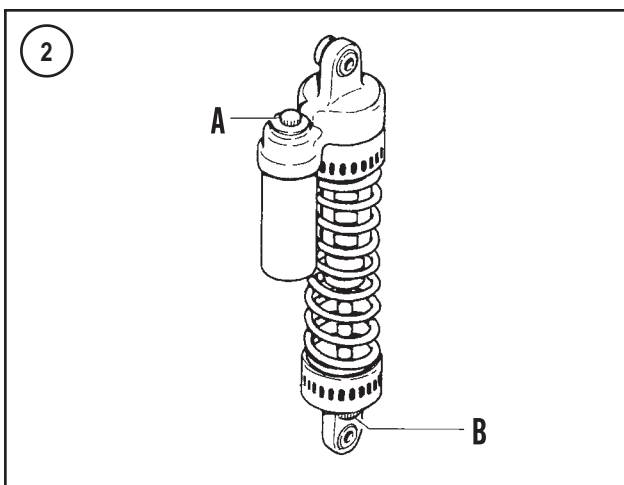

recommended setting is eight clicks from the hardest setting.

NOTE

To ensure the desired results, do not adjust the damping more than two clicks without testing the setting.

- a. Turn the compression damping adjuster (A, **Figure 2**) one or two clicks. Turning the adjuster clockwise increases compression damping, counterclockwise decreases compression damping.
 - b. Set the compression damping adjuster on the other shock absorber to the same setting.
 - c. Test ride the motorcycle.
 - d. Repeat the above steps until compression damping is at the desired level.
3. The 1200S model shock absorbers have 15 rebound damping settings. Setting 1 (fully clockwise) is the hardest; setting 15 (fully counterclockwise) the softest. The recommended setting is six clicks from the hardest setting.
- a. Turn the rebound damping adjuster (B, **Figure 2**) one or two clicks. Turning the rebound adjuster clockwise increases rebound damping; counterclockwise decreases rebound damping.
 - b. Set the rebound damping adjuster on the other shock absorber to the same setting.
 - c. Test ride the motorcycle.
 - d. Repeat the above steps until you obtain the desired rebound damping.

Removal/Installation

Removal and installation of the rear shocks is easier if they are serviced separately. The remaining unit will support the rear of the motorcycle and maintain the correct relationship between the top and bottom mounts. If both shock absorbers must be removed at the same time, cut a piece of steel a few inches longer than the shock absorber and drill two holes in the steel the same distance apart as the bolt holes in a shock absorber. Install the steel support after one shock absorber is removed. This will allow the motorcycle to be easily moved around until the shock absorbers are reinstalled or replaced.

1. Support the motorcycle so that the rear wheel clears the ground.

NOTE

*In Step 2A or 2B, 1200S models are not equipped with washers or a stud cover (**Figure 3**). Remove the appropriate fastener.*

- 2A. On 1986-1999 models, remove the upper Acorn nut, washer, stud cover and washer (**Figure 4**).
- 2B. On 2000-2003 models except 1200S models, remove the upper bolt, washer, stud On cover and washer (**Figure 5**).
3. Remove the lower locknut, bolt and washer.
4. Remove the shock absorber (**Figure 6**).

5. Install by reversing the preceding removal steps while noting the following:
 - a. Apply threadlock (Loctite 242 or equivalent) to the upper and lower shock fasteners threads.
 - b. Tighten the upper and lower fasteners as noted in **Table 1**.

Disassembly/Reassembly

Refer to **Figure 3**, **Figure 4** and **Figure 5**. The shock absorber body and spring are not available separately.

1. Remove the shock absorber as described in this section.
2. Adjust the cam ring to its softest setting.

WARNING

Do not attempt to remove the shock absorber spring without a spring compression (part No. HD-97010-52A or equivalent) or bodily injury may result.

3. Using a shock absorber spring compression tool, compress the shock absorber spring and remove the upper spring retainer. **Figure 7** shows a typical spring compressor.
4. Release spring pressure, then remove the shock absorber assembly from the tool.
5. Disassemble the shock absorber.
6. Inspect the shock absorber as described in this section.
7. Assembly is the reverse of the removal steps. Lightly grease all cam parts before assembly.

Inspection

Inspect all parts for wear or damage.

1. Replace all rubber bushings that show signs of wear, damage or cracking.
2. Check the shock absorber for fluid leaks. Replace the shock body if leaking.

SWING ARM

Removal/Installation

Refer to **Figure 8**.

1. Remove the rear wheel as described in Chapter Thirteen.

CAUTION

Cover the frame, swing arm, rear wheel and adjacent parts to protect them from accidental brake fluid spills. Brake fluid can damage painted and plastic surfaces. Immediately wash the surfaces that come into contact with brake fluid with soapy water and rinse completely.

2. Disconnect all brake hose clamps from the swing arm.

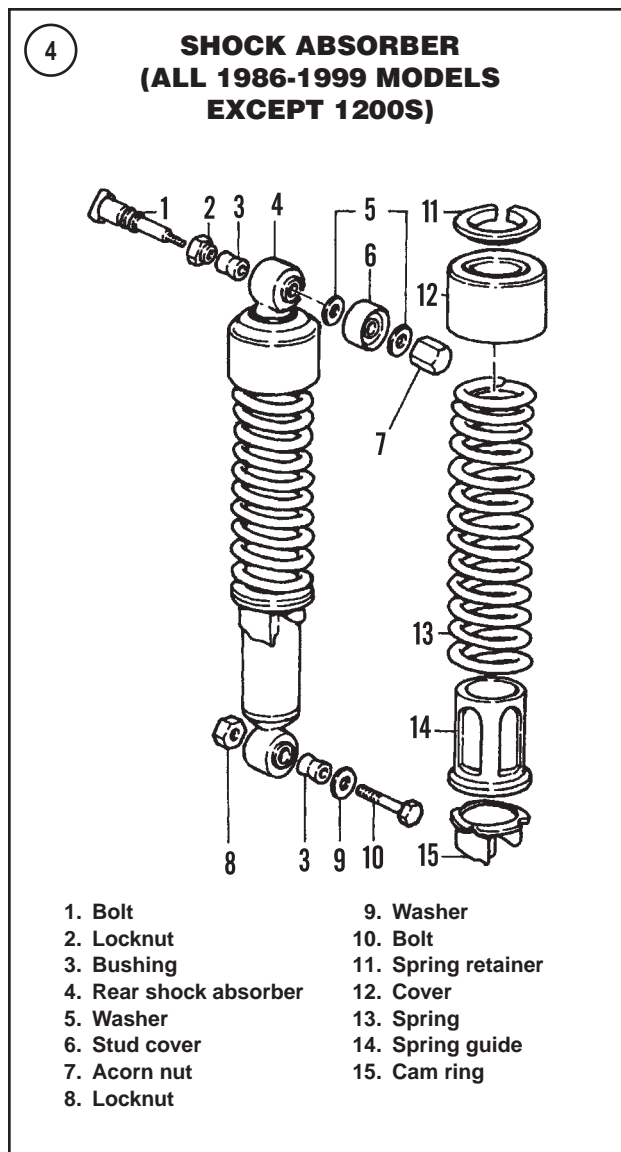

3. Remove the rear brake caliper as described in Chapter Sixteen. It is not necessary to disconnect the brakelines. Make sure to support the brake caliper so it is not hanging from the brake line.

4. Remove the bolts or nuts securing the shock absorbers to the swing arm and pull the shock absorbers clear of the mounts.

5. Remove the fasteners securing the rear chain guard and remove the guard.

6. Remove the pivot shaft covers (**Figure 9**), if so equipped.

7. Prior to completing swing arm removal, check its condition by grasping the swing arm on both sides and trying to move it from side to side. If the free play is excessive, replace the swing arm bearings as described in *Swing Arm Bearing Replacement* in this section. The manufacturer does not list free play specifications.

8. Remove the socket screw from the left side (**Figure 10**).

9. Remove the swing arm pivot bolt (**Figure 11**).

5

**REAR SHOCK ABSORBER
(ALL 2000-2003 MODELS EXCEPT 1200S MODELS)**

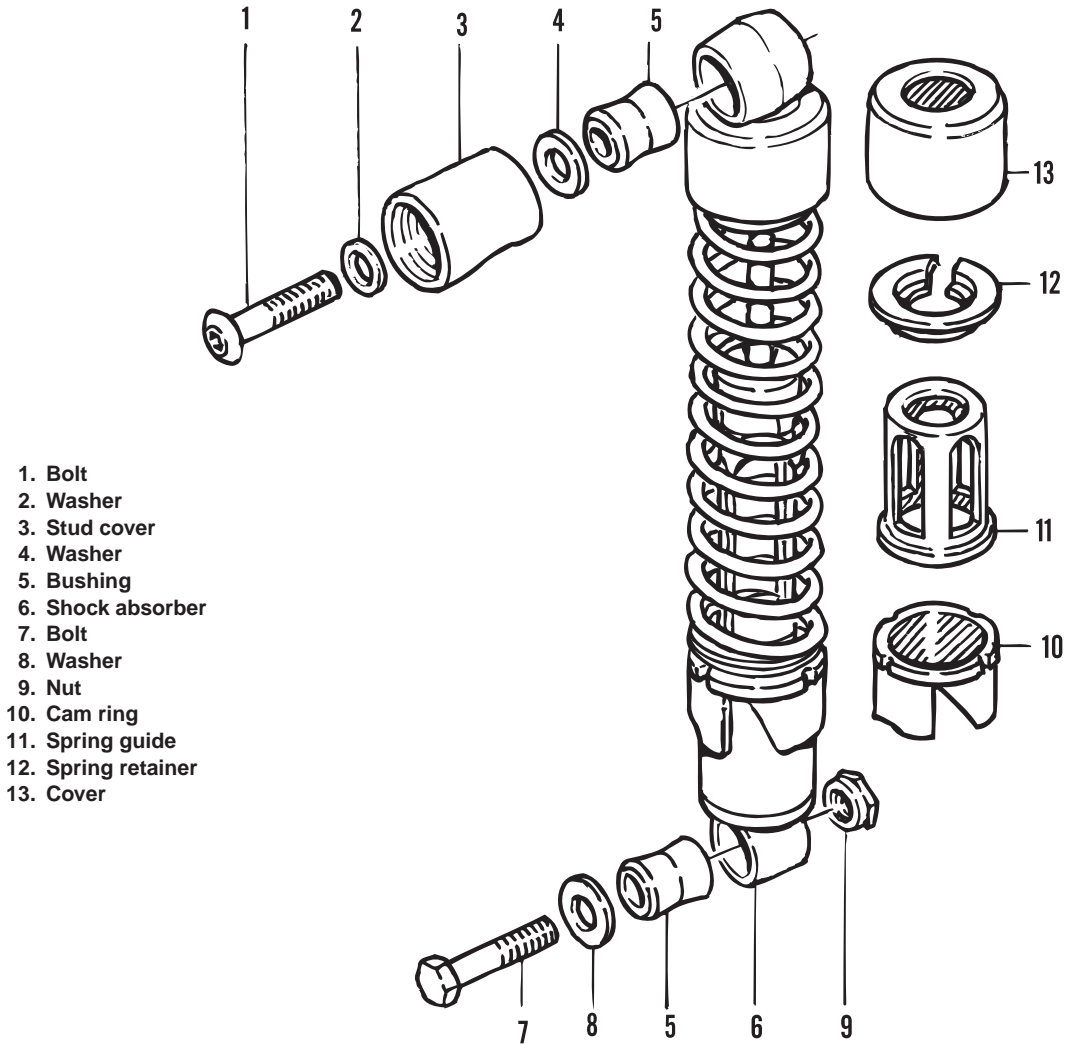

- 1. Bolt
- 2. Washer
- 3. Stud cover
- 4. Washer
- 5. Bushing
- 6. Shock absorber
- 7. Bolt
- 8. Washer
- 9. Nut
- 10. Cam ring
- 11. Spring guide
- 12. Spring retainer
- 13. Cover

6



CAUTION

Keep all bearing components together. If they fall out, reinstall them into their correct assembled positions. Wear patterns have developed on these parts and rapid wear may occur if the components are intermixed and not installed in their original positions.

- 10. Slide the swing arm out of the frame. Make sure the bearings do not drop to the ground.
- 11. Remove the pivot spacer (11, **Figure 8**) from the swing arm.
- 12. Remove the dust shields (2, **Figure 8**), inner bearing race (3, **Figure 8**), outer bearing race (4, **Figure 8**) and

bearing spacer (6, **Figure 8**). Make sure to keep all the bearing components together and with their correct assembled positioned

13. Install by reversing the preceding removal steps while noting the following.

- a. Coat the swing arm pivot shaft thoroughly with bearing grease before installation.
- b. Lubricate the bearings with waterproof bearing grease.

CAUTION

The bearing spacer must be installed between the bearings as described or the bearings will fail during operation.

- c. Install the bearing spacer between the right side bearings.
- d. Install new dust shields with their lip side positioned in toward the inner bearing races.

WARNING

*Install the pivot spacer (11, **Figure 8**) so the chamfered end faces out (left side). If the pivot spacer is installed incorrectly unstable handling may result from an insufficient clamp load.*

- e. Install the pivot spacer (11, **Figure 8**) into the pivot bushing (8, **Figure 8**) in the swing arm.
- f. If the engine is installed in the frame, insert the screw (9, **Figure 8**) into the pivot spacer (11, **Figure 8**).
- g. Slide the swing arm into position in the frame.
- h. Install the pivot bolt (**Figure 11**) from the right side. Apply threadlock (Loctite 242 or equivalent) to the threads of the screw and thread the screw (**Figure 10**) onto the end of the pivot shaft. Tighten the pivot shaft bolt to 50 ft.-lb. (68 N·m).
- i. Tighten the lower shock absorber fasteners to specifications in **Table 1**.
- j. Install the rear brake caliper (Chapter Sixteen).
- k. Adjust the drive chain or drive belt and rear brake (Chapter Three).

Swing Arm Bearing Replacement

Refer to **Figure 8**.

1. Secure the swing arm in a vise with soft jaws.

CAUTION

Tag each component when removed from the swing arm so it can be reinstalled in its original position. Bearing components must not be intermixed. Wear patterns develop on bearing assemblies and rapid wear may occur if the components are not installed in their original positions.

2. Remove the following parts from the right side in the following order:

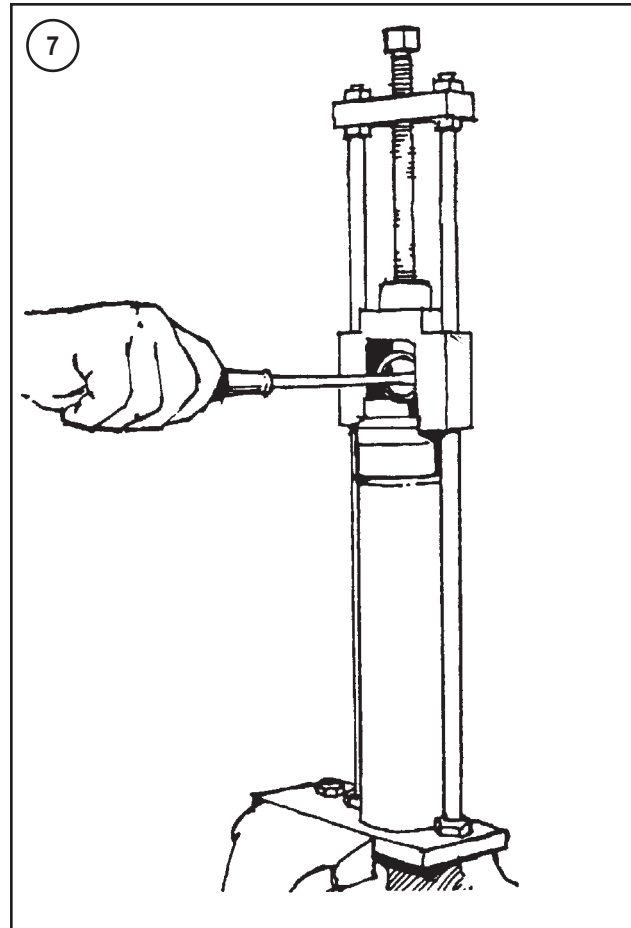

- a. Dust shields (2, **Figure 8**).
- b. Bearings (3, **Figure 8**).

CAUTION

Unless replacement is required, do not remove the outer bearing races or the pivot bushing. The complete bearing assembly must be replaced as a unit if any one bearing part is worn or damaged.

NOTE

Steps 3-9 require the use of a hydraulic press. Refer service to a dealership if a press is not available. Do not attempt to drive the bearing races or pivot bushing out of the swing arm.

3. Press the outer bearing races (4, **Figure 8**) out of the swing arm.
4. Remove and discard the lock ring (5, **Figure 8**).
5. Remove the bearing spacer (6, **Figure 8**).
6. Press the right pivot bushing (8, **Figure 8**) out of the swing arm.
7. Clean the inside of the swing arm with solvent and dry with compressed air.
8. Install a new lock ring (5, **Figure 8**).

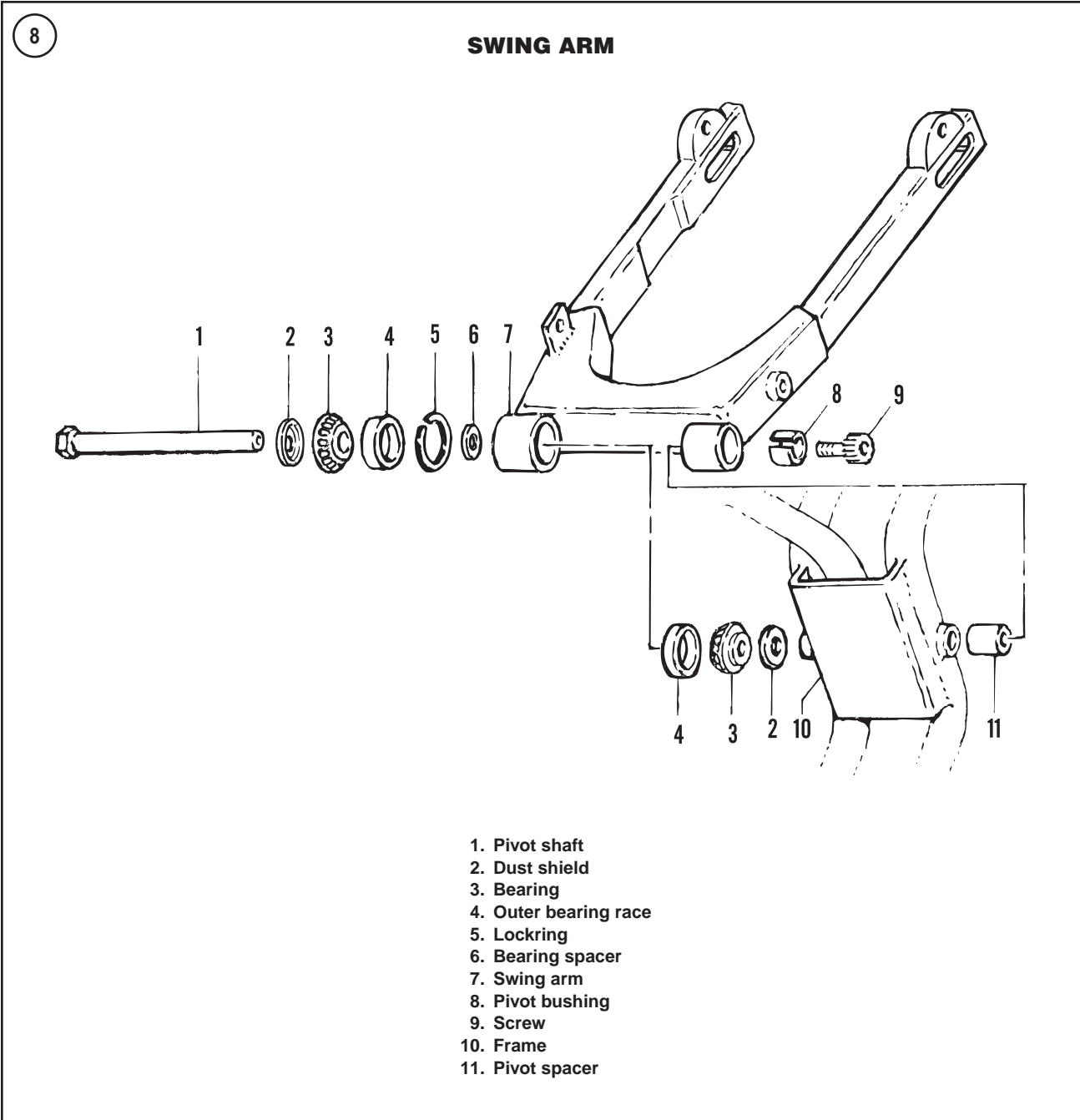

CAUTION

Never reinstall an outer bearing race that has been removed. During removal it may twist, which will affect swing arm alignment.

9. Press new bearing races (4, **Figure 8**) into position.
10. Press a new pivot bushing (8, **Figure 8**) into the swing arm on the left side.
11. Apply bearing grease to all parts.

WARNING

Install the pivot spacer (11, **Figure 8**) so the chamfered end faces outward (left side). If the pivot spacer is installed incorrectly, unstable handling may result from an insufficient clamp load.

12. Install the pivot spacer (11, **Figure 8**) into the pivot bushing.

WARNING

The bearing spacer must be installed between the bearing races during bearing in-



stallation or the bearings will fail during operation.

13. Install the bearings and bearing spacer (6, **Figure 8**) in the order shown in **Figure 8**.
14. Install dust shields over the bearing. The dust shield lip must face in.

Table 1 REAR SUSPENSION TORQUE SPECIFICATIONS

| | ft.-lb. | in.-lb. | N•m |
|--|---------|---------|-------|
| Swing arm pivot shaft bolt* | 50 | – | 68 |
| Rear shock absorber fasteners* | | | |
| Upper | | | |
| 1986-1992 models | 21-27 | – | 28-37 |
| 1993-2003 models | 21-35 | – | 28-47 |
| Lower | | | |
| 1986-1992 models | 50-55 | – | 68-75 |
| 1993-2003 models | 30-50 | – | 41-68 |
| *Apply threadlock (Loctite 242 or equivalent). | | | |

CHAPTER SIXTEEN

BRAKES

This chapter covers the front and rear brakes. **Table 1** and **Table 2** are at the end of this chapter.

BRAKE FLUID SELECTION

WARNING

Do not use brake fluid labeled DOT 5.1. This is a glycol-based fluid that is not compatible with silicone-based DOT 5. DOT 5 brake fluid is purple while DOT 5.1 is amber/clear. Do not intermix these two different types of brake fluid as it can cause brake component damage and lead to brake system failure.

WARNING

Do not intermix DOT 3, DOT 4 or DOT 5.1 brake fluids as they are not silicone-based. Using non-silicone brake fluid in these models can cause brake failure.

CAUTION

Never reuse brake fluid (like fluid expelled during brake bleeding). Contaminated brake fluid can cause brake failure. Dispose of used

brake fluid according to local or EPA toxic waste regulations.

When adding or replacing brake fluid, only use silicone-based DOT 5 brake fluid.

BRAKE SERVICE

WARNING

Do not ride the motorcycle unless the brakes work correctly. The proper operation of this system depends on a supply of clean brake fluid (DOT 5) and a clean work environment when any service is being performed. Any tiny particle of debris that enters the system can damage the components and cause poor brake performance.

WARNING

When working on the brake system, do not inhale brake dust. It may contain asbestos, which is a known carcinogen. Do not use compressed air to blow off brake dust. Use an aerosol brake cleaner. Wet down the brake components before working on the brake sys-

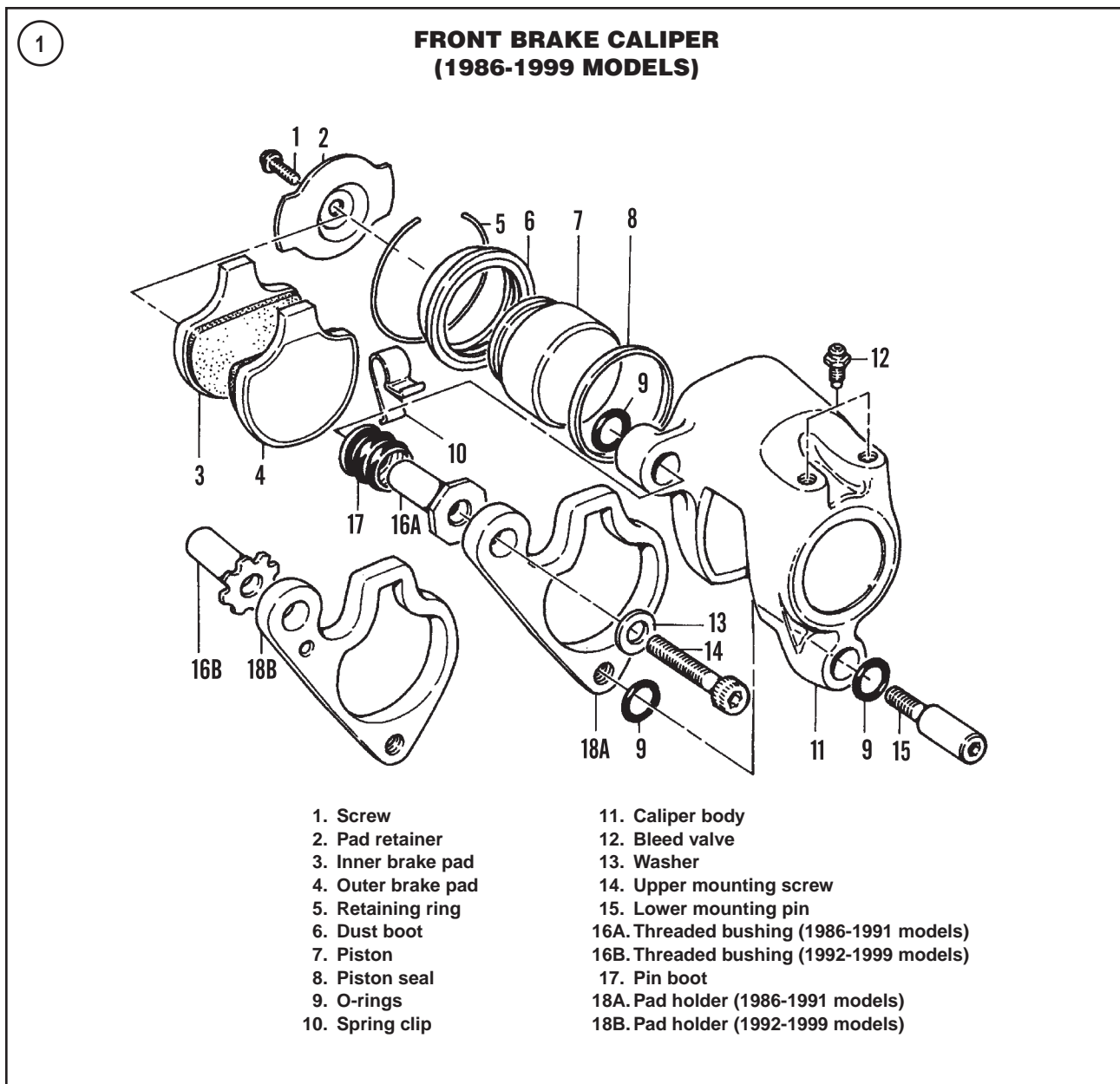

tem. Dispose of all brake dust and cleaning materials properly. Wear a facemask that meets OSHA requirements. Wash thoroughly after completing the work.

The disc brake system transmits hydraulic pressure from the master cylinders to the brake calipers. This pressure is transmitted from the calipers to the brake pads, which grip both sides of the brake discs and slow the motorcycle. As the pads wear, the pistons move out of the caliper bores to automatically compensate for wear. As this occurs, the fluid level in the master cylinder reservoir goes down. This must be compensated for by occasionally adding fluid.

Use only fluid clearly marked DOT 5. If possible, use the same brand of fluid. Do not replace the fluid with a glycol-based fluid (DOT 3, 4 or 5.1). It is not possible to remove all of the old fluid. Other types are not compatible with DOT

5. Do not reuse drained fluid. Discard old fluid properly. Do not combine brake fluid with fluids for recycling.

Perform brake service procedures carefully. Do not use any sharp tools inside the master cylinders or calipers or on the pistons. Damage of these components could cause a loss of system hydraulic pressure.

Consider the following when servicing the brake system:

1. The hydraulic components rarely require disassembly. Make sure it is necessary.
2. Keep the reservoir covers in place to prevent the entry of moisture and debris.
3. Clean parts with an aerosol brake parts cleaner or denatured alcohol. Never use petroleum-based solvents on internal brake system components. They will cause seals to swell and distort.



4. Do not allow brake fluid to contact plastic, painted or plated parts. It will damage the surface.
5. Before performing any procedure where there is a possibility of brake fluid contacting the motorcycle, cover the work area with a heavy tarp or a large piece of plastic.
6. Before handling brake fluid or working on the brake system, fill a small container with soap and water and keep it close to the motorcycle while working. If brake fluid contacts the motorcycle, clean the area and rinse thoroughly.
7. To help control the flow of brake fluid when filling the reservoirs, punch a small hole into the seal of a new container next to the edge of the pour spout.

8. If the hydraulic system, not including the reservoir cover, has been opened, bleed the system to remove air from the system. Refer to *Bleeding the System* in this chapter.
9. Dispose of brake fluid properly.

FRONT BRAKE PADS (1986-1999 MODELS)

There is no recommended mileage interval for changing the front brake pads. Pad wear depends on riding habits and conditions. Frequently inspect brake pads for wear. Increase the inspection interval when the wear indicator reaches the edge of the brake disc. After removal, measure the thickness of each pad. Replace the pads if they are worn to 0.062 in. (1.6 mm).

Always replace the front brake pads as a set. If equipped with dual front calipers, never replace the brake pads in one caliper without also replacing them in the other caliper.

Do not disconnect the brake hose from the caliper for brake pad replacement. Only disconnect the brake hose if the caliper is going to be removed.

As the brake pads wear, the brake fluid level drops in the reservoir and automatically adjusts for wear. Check brake fluid level often.

Inspection

Refer to *Periodic Maintenance* in Chapter Three.

Replacement

Refer to **Figure 1**.

1. Review *Brake Service* in this chapter.
2. Place a spacer between the brake lever and the throttle grip, and secure it in place. If the brake lever is inadvertently applied, this prevents the pistons from being forced out of the cylinders. If the piston is pushed out of the cylinder the caliper must be reassembled as described in *Front Brake Caliper (1986-1999 Models)* in this chapter.
3. Loosen the upper mounting screw (A, **Figure 2**) and the lower mounting pin (B). Remove the upper screw and its washer and the mounting pin.
4. Lift the brake caliper off of the brake disc.

NOTE

If the brake pads will be reused, mark each pad so that it can be reinstalled in its original mounting position in the caliper.

5. Remove the outer pad, pad holder and spring clip as an assembly (**Figure 3**).
6. Remove the screw (A, **Figure 4**), pad retainer (B) and inner pad (**Figure 5**).
7. Push the outer pad (A, **Figure 6**) free of the spring clip (B) and remove it. See **Figure 7**.

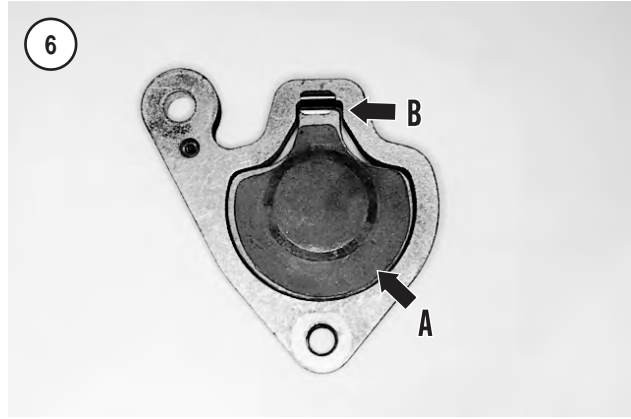

8. Check the brake pads (**Figure 7**) for wear or damage. Replace the brake pads if they are worn to 0.062 in. (1.6 mm) or less (**Figure 8**). Replace both pads as a set.

9. Inspect the caliper upper mounting screw (A, **Figure 9**) and mounting pin (B). If either part has damaged threads or is worn or badly corroded, replace the damaged part. Replace the mounting pin if its shoulder is scored or otherwise damaged.

10. Replace the pad retainer (**Figure 10**) if cracked or deformed.

11. Check the piston dust boot (**Figure 11**). If the boot is swollen or cracked or if brake fluid is leaking from the caliper bore, remove the caliper and overhaul it as described in *Front Brake Caliper* in this chapter.

12. Remove all corrosion from the pad holder.

13. Replace the spring clip (B, **Figure 6**) if worn, cracked or badly corroded.

14. Check the brake disc for wear as described in this chapter. Service the brake disc if necessary.

15. Assemble the pad holder, spring clip and outer brake pad (**Figure 12**) as follows:

- a. Lay the pad holder on a workbench so the upper mounting screw hole is positioned at the upper right as shown in A, **Figure 13**.
- b. Install the spring clip (B, **Figure 13**) at the top of the pad holder so the spring loop faces in the direction shown in **Figure 12**.
- c. The outer brake pad (A, **Figure 6**) has an insulator pad mounted on its backside.
- d. Center the outer brake pad into the pad holder so the lower end of the pad rests inside the pad holder. Then push firmly on the upper end of the brake pad, past the spring clip and into the holder. The pad should be held firmly by the spring in the spring holder. Refer to **Figure 13**.

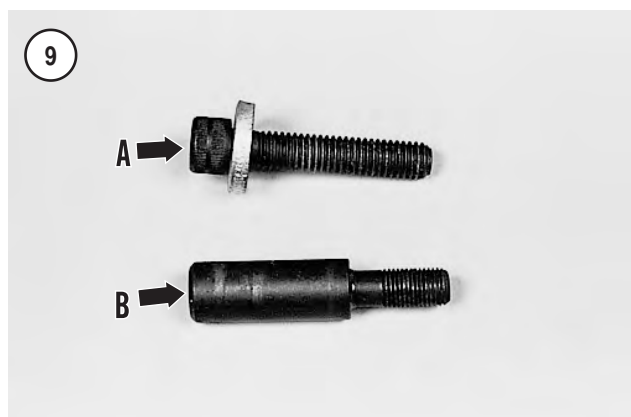
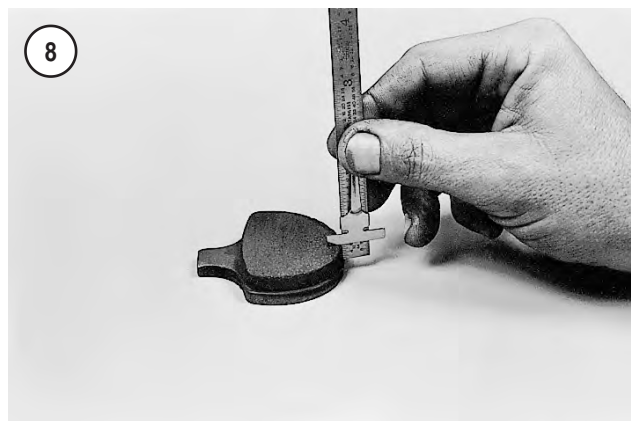

CAUTION

Do not allow the master cylinder to overflow. Brake fluid back flows to the reservoir as the pistons are pushed back into their bores. Because brake fluid damages most surfaces, immediately wash spilled brake fluid off

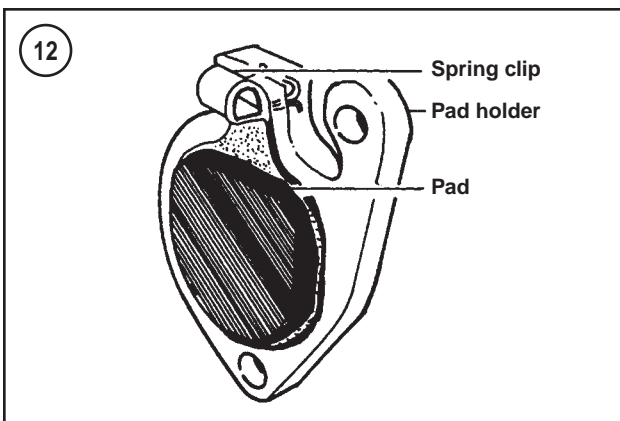

surfaces it contacts. Use soapy water and rinse completely.

16. Remove the master cylinder cover (**Figure 14**) and diaphragm. Use a shop syringe and remove about 50% of the brake fluid in the reservoir. This prevents the master cylinder from overflowing when the pistons are compressed for pad installation. Do not drain more than 50% of the brake fluid, or air may enter the system. Discard fluid properly.

17. Push the piston into the cylinder with your fingers. Reinstall the master cylinder cover and diaphragm, but do not tighten the screws.

NOTE

The piston should move freely. If not, and there is evidence of it sticking in the caliper bore, remove the caliper and service it as described in this chapter.

18. Install the inner brake pad (**Figure 5**) in the caliper recessed seat. The inner pad does not have an insulator backing.

19. Insert the pad retainer (B, **Figure 4**) in the caliper counterbore. Install the self-tapping screw (A, **Figure 4**) through the pad retainer and thread it into the brake pad. Tighten the screw to 40-50 in.-lb. (5-6 N•m).

20. Insert the outer brake pad/pad holder assembly into the caliper so that the brake pad insulator backing faces against the piston. See **Figure 3**.

CAUTION

*On 1992-1999 models, the threaded bushing head must be installed between the rivet head and the pad holder. On 1992 models, one of the U-shaped notches on the outer bushing flange must engage the rivet as shown. On 1993-1999 models, the U-shaped notch on the outer bushing flange must engage the rivet. If the bushing is positioned incorrectly, the rivet will be damaged when the caliper mounting screw, and pin are tightened. Refer to **Figure 1**.*

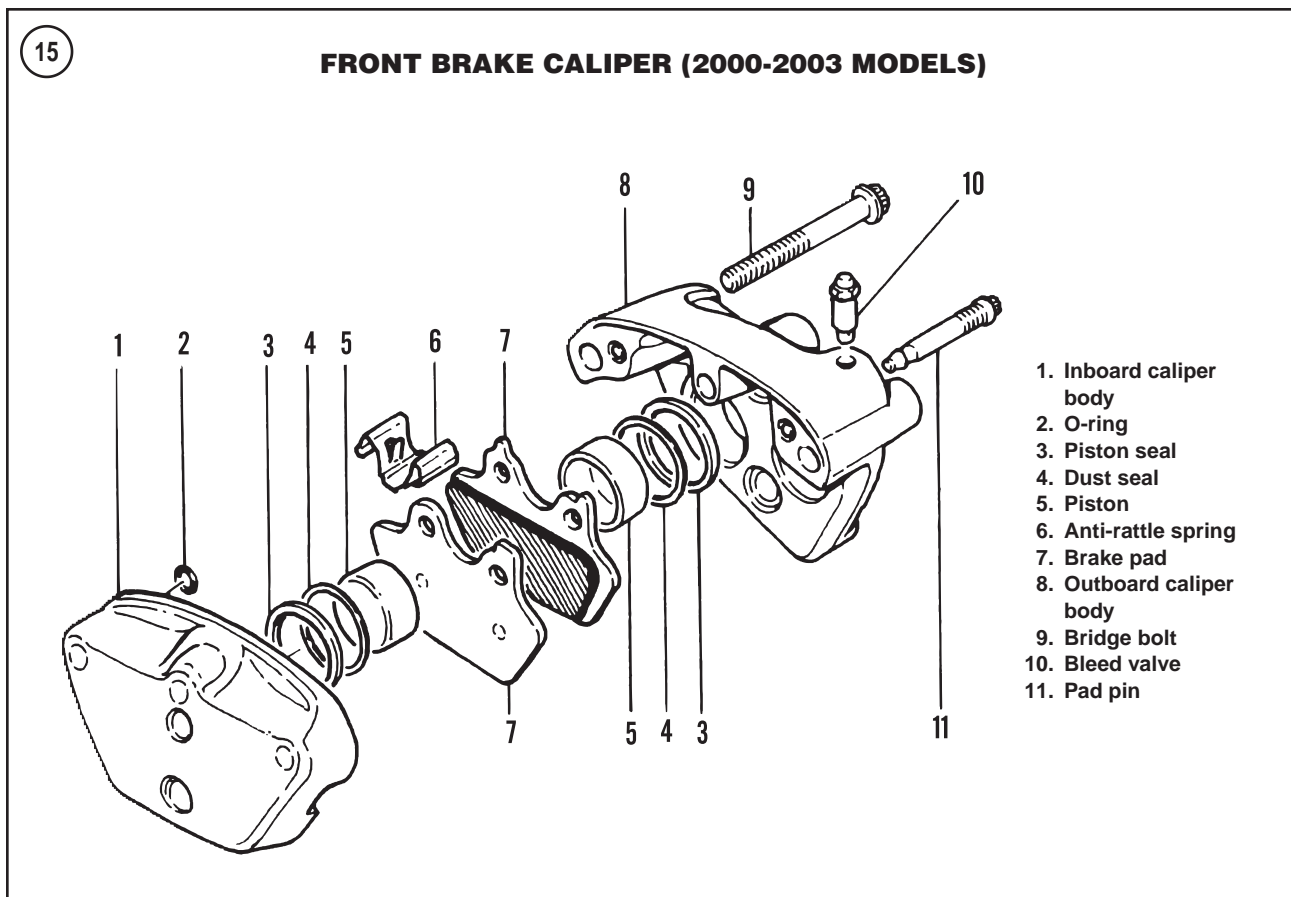
**WARNING**

The spring clip loop and the brake pad friction material must face away from the piston when the pad holder is installed in the caliper. Brake failure will occur if the brake pads are assembled incorrectly.

21. Coat the lower mounting pin shoulder with high-temperature bearing/brake grease (Dow Corning Moly 44 or equivalent).
22. Install the caliper over the brake disc, making sure the friction surface on each pad faces against the disc.
23. Align the two mounting holes in the caliper with the slider mounting lugs.
24. Install a washer onto the upper mounting screw (A, **Figure 2**) and insert the screw through the slider lug and then thread into the caliper bushing. Install the screw finger-tight.
25. Insert the lower mounting pin (B, **Figure 2**) through the caliper and then thread into the slider lug. Tighten the mounting pin finger-tight.
26. Tighten the lower mounting pin to 25-30 ft.-lb. (34-41 N•m).
27. Tighten the upper mounting screw to 25-30 ft.-lb. (34-41 N•m).
28. Refill the master cylinder reservoir with DOT 5 silicone-based brake fluid, if necessary, to maintain the correct fluid level. Install the diaphragm and top cap (**Figure 14**).

29. While the motorcycle is stationary with the engine off, squeeze the front brake lever several times to seat the pads against the disc.

WARNING

Do not ride the motorcycle until the brakes are operating correctly. If necessary, bleed the brake as described in this chapter.

30. Bed the pads in gradually for the first 100 miles (160 km) of riding by using only light pressure as much as possible. Immediate hard application glazes the new friction pads and reduces their effectiveness.

FRONT BRAKE PADS (2000-2003 MODELS)

There is no recommended mileage interval for changing the front brake pads. Pad wear depends on riding habits and conditions. Frequently inspect brake pads for wear. Increase the inspection interval when the wear indicator reaches the edge of the brake disc. After removal, measure the thickness of each pad. Replace the pads if they are worn to 0.062 in. (1.6 mm).

Always replace the front brake pads as a set. If equipped with dual front calipers, replace both sets of pads.

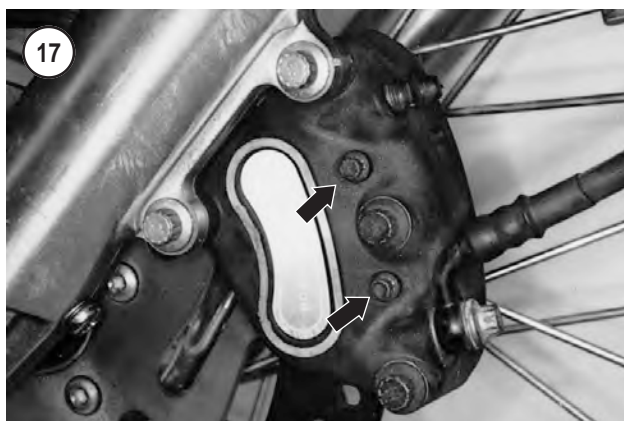

Do not disconnect the brake hose from the caliper for brake pad replacement. Only disconnect the brake hose if the caliper is going to be removed.

As the brake pads wear, the brake fluid level drops in the reservoir and automatically adjusts for wear. Check brake fluid level often.

Replacement

Refer to **Figure 15**.

1. Review *Brake Service* in this chapter.
2. Place a spacer between the brake lever and the throttle grip, and secure it in place. If the brake lever is inadver-

tently applied, this will prevent the pistons from being forced out of the cylinders. If the piston is pushed out of the cylinder, the caliper must be reassembled as described in *Front Brake Caliper (2000-2003 Models)* in this chapter.

3. Clean the top of the master cylinder.
4. Remove the screws (A, **Figure 16**) securing the cover, the cover (B) and diaphragm.

CAUTION

Do not allow the master cylinder to overflow. Brake fluid back flows to the reservoir as the pistons are pushed back into their bores. Because brake fluid damages most surfaces, immediately wash spilled brake fluid off surfaces it contacts. Use soapy water and rinse completely.

5. Use a shop syringe and remove about 50% of the brake fluid from the reservoir. This prevents the master cylinder from overflowing when the pistons are compressed for reinstallation. Do not drain more than 50% of the brake fluid or air will enter the system. Discard the brake fluid properly.
6. Loosen the pad pins (**Figure 17**).

CAUTION

The brake disc is thin in order to dissipate heat and may bend easily. When pushing against the disc, support the disc adjacent to the caliper to prevent damage to the disc.

7. Hold the caliper body from the outside and push it toward the brake disc. This will push the outer pistons into the caliper bores to make room for the new brake pads. Constantly check the reservoir to make sure brake fluid does not overflow. Remove fluid, if necessary, before it overflows. Install the diaphragm and cover. Tighten the screws finger-tight.
8. Remove the caliper mounting bolts (**Figure 18**) and remove the caliper from the front fork.
9. Remove the pad pins (**Figure 17**).
10. Remove the inboard and outboard brake pads from the caliper.
11. Check the brake pads for uneven wear or damage.
12. Remove rust or corrosion from the brake disc.
13. Clean the pad pins of corrosion or dirt.
14. Check the friction surface of the new pads for debris or manufacturing residue. If necessary, clean them with an aerosol brake cleaner.

NOTE

When purchasing new pads, check with the parts supplier to make sure the friction compound of the new pad is compatible with the disc material. Remove roughness from the backs of the new pads with a fine-cut file, then thoroughly clean them.

NOTE

*The pads are not symmetrical. The pad with one tab (A, **Figure 19**) must be installed on the inboard side of the left side caliper and on the*

outboard side of the right side caliper. The pad with two tabs (B, **Figure 19**) must be installed on the outboard side of the left side caliper and on the inboard side of the right side caliper.

15. Install the outboard pad (**Figure 20**). Hold the pad in place against the anti-rattle spring and install both pad pins (**Figure 21**) through the caliper and the outboard brake pad.
16. Install the inboard pad (**Figure 22**) into the caliper. Hold the pad in place against the anti-rattle spring and push both pad pins through the inboard brake pad and into the caliper. Tighten the pad pins finger-tight.
17. Separate the brake pads (**Figure 23**) to allow room for the brake disc.
18. Install the caliper onto the brake disc and install the mounting bolts (**Figure 18**). Tighten the bolts to 28-38 ft.-lb. (38-52 N•m).
19. Tighten the pad pin bolts (**Figure 17**) to 180-204 in.-lb. (20-23 N•m).
20. Remove the spacer from the front brake lever.
21. Make sure there is sufficient brake fluid in the master cylinder reservoir. Top it off if necessary.
22. Pump the front brake lever several times to reposition the brake pads against the brake disc.
23. Refill the master cylinder reservoir, if necessary, to maintain the correct fluid level as indicated on the side of the reservoir. Install the diaphragm and the top cover. Tighten the screws to 6-8 in.-lb. (0.5-1 N•m).

WARNING

Do not ride the motorcycle until the brakes are operating correctly. If necessary, bleed the brake as described in this chapter.

24. Bed the pads in gradually for the first 100 miles (160 km) of riding by using only light pressure as much as possible. Immediate hard application glazes the new friction pads and greatly reduces their effectiveness.

FRONT BRAKE CALIPER (1986-1999 MODELS)

Review *Brake Service* in this chapter.

Removal

1. Remove the upper mounting screw and washer (A, **Figure 24**) and the lower mounting pin (B).
2. Lift the brake caliper off the brake disc.
- 3A. If the caliper is going to be disassembled for service, perform the following:

NOTE

If the brake pads will be reused, mark each pad so it can be reinstalled in its original position in the caliper.

- a. Remove the brake pads as described in this chapter.

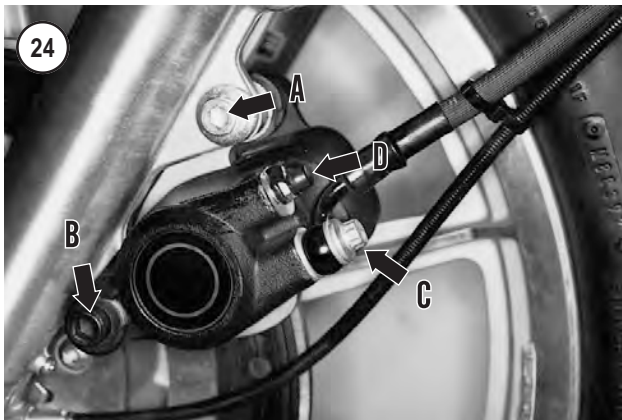

**CAUTION**

Do not allow the pistons to travel out far enough to contact the brake disc. If this happens, the pistons may damage the disc during caliper removal.

- b. Slowly apply the front brake lever to push the piston part way out of the caliper for ease of removal during caliper service.

3B. If caliper service is not required, insert a spacer between the brake pads (**Figure 25**) in the caliper. The spacer prevents the piston from being forced out of the caliper if the brake lever is squeezed while the caliper is removed from the brake disc. If the pistons are forced out, disassemble the caliper and reseat the pistons as described in this chapter.

NOTE

If complete removal of the caliper is not necessary, suspend the caliper and disregard the remaining steps. Do not let the caliper hang from the brake line.

4. Drain the brake fluid from the front brake hose as described in *Brake Hose and Line Replacement* in this chapter.
5. Remove the banjo bolt from the caliper (C, **Figure 24**). Remove the bolt and the two washers. Place the open hose end into a plastic bag to prevent spills and to keep out dirt.
6. Remove the caliper. Place it in a plastic bag until installation or disassembly.

Installation**WARNING**

The upper and lower caliper bushings must be installed in the fork slider prior to installing the brake caliper. Otherwise, the caliper and pad will be improperly located in relation to the brake disc. This condition will bind the caliper and brake pads, causing uneven braking and possible brake lockup.

1. Make sure the upper and lower caliper bushings, installed in the fork slider, are in place (**Figure 26**, typical).
2. If removed, install the brake pads as described in this chapter.
3. Coat the lower mounting pin with high-temperature bearing/brake grease (Dow Corning Moly 44 or equivalent).
4. Align the two mounting holes in the caliper with the fork slider mounting lugs.
5. Install a washer onto the upper mounting screw and insert the screw (A, **Figure 24**) through the slider lug and then thread into the caliper bushing. Install the screw finger-tight.
6. Insert the lower mounting pin (B, **Figure 24**) through the caliper and thread it into the slider lug. Tighten the mounting screw finger-tight.

7. Tighten the lower mounting pin (B, **Figure 24**) to 25-30 ft.-lb. (34-41 N•m)
8. Tighten the upper mounting screw (A, **Figure 24**) to 25-30 ft.-lb. (34-41 N•m).
9. Tighten the bleed valve (D, **Figure 24**) to 80-100 in.-lb. (9-11 N•m).
10. If removed, assemble the brake line onto the caliper by placing a *new* washer (**Figure 27**) on both sides of the brake line fitting, then secure the fitting to the caliper with the banjo bolt (C, **Figure 24**). Tighten the banjo bolt to 17-22 ft.-lb. (23-30 N•m). Orient the fitting against the caliper as shown in C, **Figure 24**.
11. If necessary, refill the system and bleed the brakes as described in this chapter.
12. While the motorcycle is stationary with the engine off, squeeze the front brake lever several times to seat the pads against the disc.

WARNING

Do not ride the motorcycle until the brakes operate properly.

Disassembly

Refer to **Figure 28**.

1. Partially remove the piston from the caliper as described during caliper removal in this section.

WARNING

Compressed air will force the piston out of the caliper under considerable force. Do not block the piston by hand as injury will occur.

2. Insert a small screwdriver into the notched groove machined in the bottom of the piston bore (**Figure 29**). Then pry the retaining ring (**Figure 30**) out of the caliper body.
3. If the piston did not come partially out of the caliper bore, perform the following:
 - a. Place a rag and a wood block in the caliper (**Figure 31**). Keep fingers out of the way of the piston.
 - b. Apply compressed air through the brake hose port and force the piston out of the caliper.
4. Remove the piston and dust boot assembly (**Figure 32**).
5. Remove the piston seal (**Figure 33**) from the groove in the caliper body.
6. Pull the threaded bushing (A, **Figure 34**) out of the caliper, then remove the pin boot (B).
7. Remove the O-rings from the caliper body (**Figure 35**).

Inspection

Service specifications for the front caliper components are not available from the manufacturer. Replace worn, damaged or questionable parts.

1. Clean the caliper body and piston in new DOT 5 brake fluid or isopropyl alcohol, and dry them with compressed air.



2. Make sure the fluid passageway in the base of the piston bore is clear. Apply compressed air to the opening to make sure it is clear. Clean it out, if necessary, with new brake fluid.
3. Inspect the piston seal groove in the caliper body for damage. If it is damaged or corroded, replace the caliper assembly.
4. Inspect the banjo bolt threaded hole in the caliper body. If it is worn or damaged, renew it using an appropriately sized thread tap or replace the caliper assembly.
5. Inspect the bleed valve threaded hole in the caliper body. If it is worn or damaged, renew it using an appropriately sized thread tap or replace the caliper assembly.
6. Inspect the bleed valve. Apply compressed air to the opening and make sure it is clear. Clean it out with new brake fluid. Install the bleed valve and tighten it to 80-100 in.-lb. (9-10 N•m).
7. Inspect the caliper body for damage.
8. Inspect the cylinder wall and piston (**Figure 36**) for scratches, scoring or other damage.

Assembly

1. An original equipment rebuild kit includes a piston seal (A, **Figure 37**), piston (B), dust boot (C) and retaining ring (D).

WARNING

Never reuse an old dust boot or piston seal. Very minor damage or age deterioration can result in leaks and possible brake failure.

2. Soak the new dust and piston seal in clean DOT 5 brake fluid.
3. Install the new piston seal into the groove. Make sure the seal is properly seated in its groove.
4. Install new O-rings into the caliper grooves.
5. Wipe the inside of the pin boot with high-temperature bearing/brake grease (Dow Corning Moly 44 or equivalent). Then insert the boot into the bushing bore with the flange end seating in the bore groove (**Figure 38**).
6. Insert the threaded bushing into the boot (**Figure 39**).
7. Install the piston dust boot on the piston before the piston is installed in the caliper bore. Perform the following:

28

FRONT BRAKE CALIPER (1986-1999 MODELS)

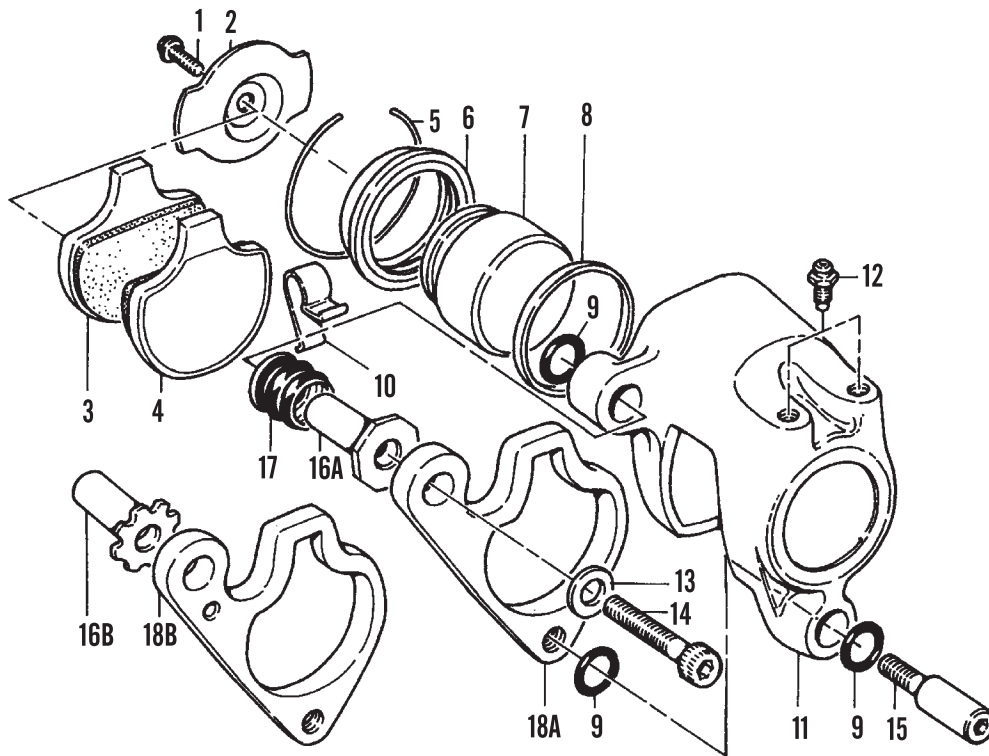

- | | |
|--------------------|--|
| 1. Screw | 11. Caliper body |
| 2. Pad retainer | 12. Bleed valve |
| 3. Inner brake pad | 13. Washer |
| 4. Outer brake pad | 14. Upper mounting screw |
| 5. Retaining ring | 15. Lower mounting pin |
| 6. Dust boot | 16A. Threaded bushing (1986-1991 models) |
| 7. Piston | 16B. Threaded bushing (1992-1999 models) |
| 8. Piston seal | 17. Pin boot |
| 9. O-rings | 18A. Pad holder (1986-1991 models) |
| 10. Spring clip | 18B. Pad holder (1992-1999 models) |

29



30



16

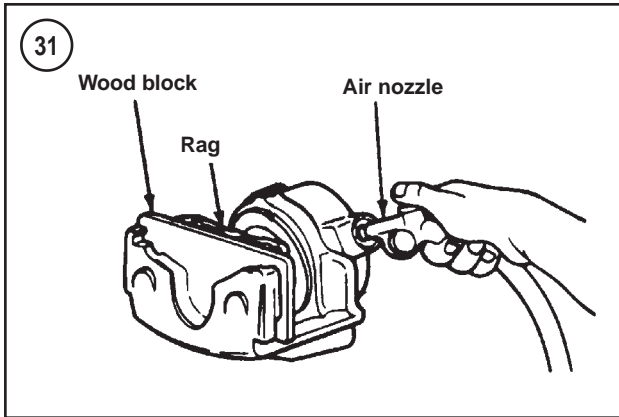

- a. Place the piston on the workbench with its open side facing up.
- b. Align the piston dust boot with the piston so the shoulder on the dust boot faces up.
- c. Slide the piston dust boot onto the piston until the inner lip on the dust boot seats in the piston groove (**Figure 32**).

8. Coat the piston and the caliper bore with DOT 5 brake fluid.

9. Align the piston with the caliper bore so its open end faces out (**Figure 32**). Push the piston into the bore until it bottoms.

10. Seat the piston dust boot (**Figure 40**) into the caliper bore.

11. Locate the retaining ring groove in the top end of the caliper bore. Align the retaining ring so its gap (**Figure 41**) is at the top of the caliper bore and install the ring into the ring groove. Make sure the retaining ring is correctly seated in the groove.

12. Apply a light coat of high-temperature bearing/brake grease (Dow Corning Moly 44 or equivalent) to the caliper mounting lug bores.

13. If the bleed valve was removed, install it and tighten it to 80-100 in.-lb. (9-11 N•m).

14. Install the caliper and brake pads as described in this section.

15. Bleed the brakes as described in *Bleeding the System* in this chapter.



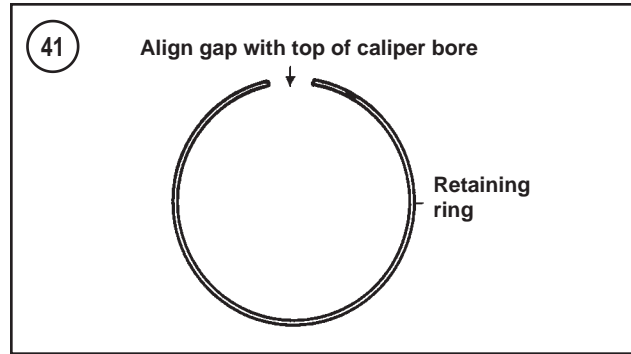

FRONT BRAKE CALIPER (2000-2003 MODELS)

Review *Brake Service* in this chapter.

Removal

1. If the caliper is going to be disassembled for service, perform the following:

NOTE

If the brake pads will be reused, mark each pad so it can be reinstalled in its original position in the caliper.

- a. Remove the brake pads as described in this chapter.

CAUTION

Do not allow the pistons to travel out far enough to contact the brake disc. If this happens, the pistons may damage the disc during caliper removal.

- b. Slowly apply the brake lever to push the pistons part way out of the caliper assembly for ease of removal during caliper service.
 - c. Loosen the two body mounting bolts (A, **Figure 42**).
 - d. Loosen the brake hose banjo bolt (B, **Figure 42**).
2. Remove the banjo bolt and sealing washers (B, **Figure 42**). Account for the sealing washer on each side of the hose fitting(s).

- Place the loose end of the brake hose in a plastic bag to prevent the entry of debris and keep brake fluid from leaking out.
- Remove the mounting bolts (**Figure 43**).
- Remove the caliper. Place it in a plastic bag until installation or disassembly.

Installation

- Install the caliper assembly onto the disc, take care not to damage the leading edge of the brake pads.
- Install the mounting bolts (**Figure 43**). Install the long bolt into the upper hole. Install the upper bolt finger-tight, then install the lower bolt. Tighten the lower bolt to 28-38 ft.-lb. (38-52 N•m). Tighten the upper bolt to 28-38 ft.-lb. (38-52 N•m).
- Apply new DOT 5 brake fluid to the rubber portions of the new banjo bolt sealing washers prior to installation.
- Install a new sealing washer on each side of the brake hose fitting and install the banjo bolt (B, **Figure 42**). Tighten the banjo bolt to 17-22 ft.-lb. (23-30 N•m).
- Bleed the brake as described in this chapter.

Disassembly

Refer to **Figure 44**.

- Remove the caliper as described in this section.
- Remove the two caliper body bolts (**Figure 45**) loosened during the removal procedure.
- Separate the caliper body halves. Remove the O-rings (**Figure 46**). New O-rings must be installed every time the caliper is disassembled.

NOTE

If the pistons were partially forced out of the caliper body during removal, steps 4-6 may not be necessary. If the pistons or caliper bores are corroded or very dirty, compressed air may be necessary to completely remove the pistons from the body bores.

- Place a piece of soft wood and a shop cloth over the end of the pistons and the caliper body. Turn this assembly over with the pistons facing down on top of a workbench.

WARNING

Compressed air forces the pistons out of the caliper body under considerable force. Do not block the piston by hand, as injury will result.

- Apply the air pressure in short spurts to the hydraulic fluid passageway and force out the pistons. Repeat for the other caliper body half.

CAUTION

Do not use a sharp tool to remove the dust and piston seals from the caliper cylinders. Do not damage the cylinder surface.



- Use a piece of wood or a plastic scraper and push the dust seal and the piston seal (**Figure 47**) in toward the caliper cylinder and out of their grooves. Remove the dust and piston seals.
- If necessary, unscrew and remove the bleed valve (A, **Figure 48**).
- Inspect the caliper as described in this section.

Inspection

- Clean both caliper body halves and pistons in new DOT 5 brake fluid or isopropyl alcohol and dry with compressed air.
- Make sure the fluid passageways (**Figure 49**) in the piston bores are clear. Apply compressed air to the openings to make sure they are clear. Flush the passageways, if necessary, with new brake fluid.
- Make sure the fluid passageways (A, **Figure 50**) in both caliper body halves are clear. Apply compressed air to the openings to make sure they are clear. Flush the passageways, if necessary, with new brake fluid.
- Inspect the piston and dust seal grooves (**Figure 51**) in both caliper bodies for damage. If damaged or corroded, replace the caliper assembly.
- Inspect the banjo bolt threaded hole (B, **Figure 48**) in the outboard caliper body. If worn or damaged, renew with an appropriately sized thread tap or replace the caliper assembly.
- Inspect the bleed valve threaded hole in the caliper body. If worn or damaged, clean out with an appropriately sized thread tap or replace the caliper body.
- Inspect the bleed valves (A, **Figure 48**). Apply compressed air to the opening and make sure it is clear. Clean out, if necessary, with clean brake fluid. Install the bleed valve and tighten to 80-100 in.-lb. (9.0-11.3 N•m).
- Inspect both caliper body halves for damage. Check the inboard caliper mounting bolt hole threads (B, **Figure 50**) for wear or damage. Clean up the threads with an appropriately sized tap or replace the caliper assembly.
- Inspect the cylinder walls and pistons for scratches, scoring or other damage.

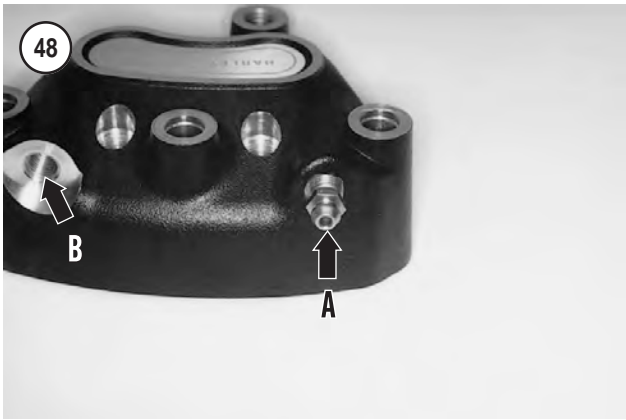
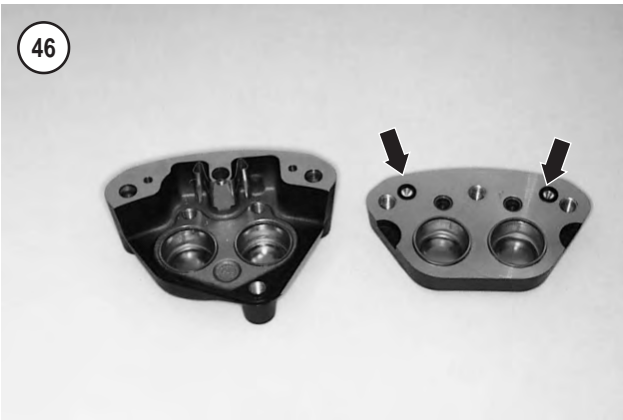
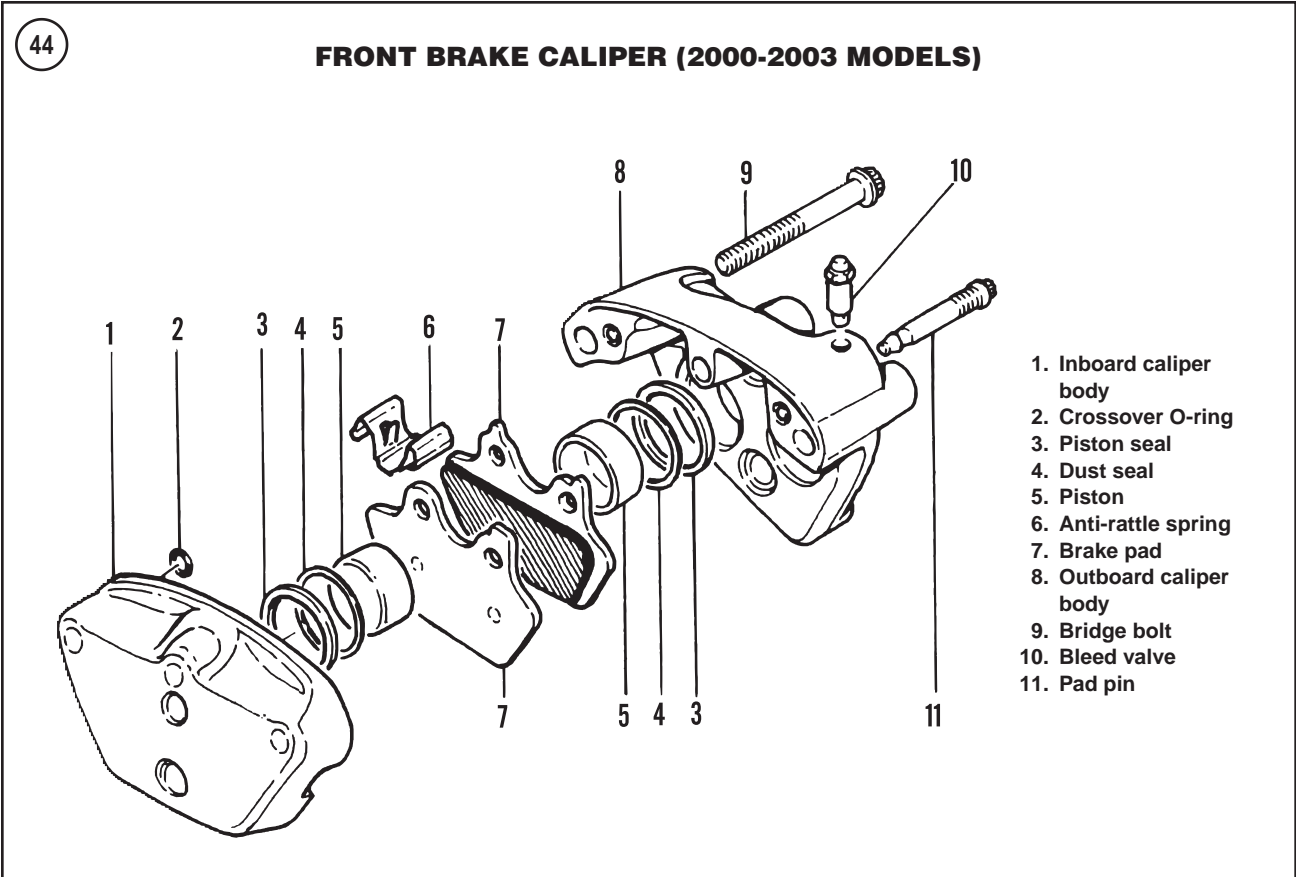

10. Check the anti-rattle spring (**Figure 52**) for wear or damage.

Assembly

CAUTION

Never reuse old dust seals or piston seals. Very minor damage or age deterioration can result in leaks and possible brake failure.

1. Soak the new dust and piston seals in new DOT 5 brake fluid.
2. Coat the piston bores and pistons with new DOT 5 brake fluid.
3. Install the new piston seals into the lower grooves. Make sure the seals are properly seated in their respective grooves.
4. Install the new dust seals into the upper grooves. Make sure all seals are properly seated in their respective grooves (**Figure 53**).
5. Repeat Step 3 and Step 4 for the other caliper body half.
6. Position the pistons with the open end facing out and install the pistons into the caliper cylinders (A, **Figure 54**). Push the pistons into the bore until they bottom (B).
7. Repeat Step 6 for the other caliper body half. Make sure all pistons are installed correctly.
8. Coat the new O-ring seals in new DOT 5 brake fluid and install the O-rings (**Figure 46**) into the inboard caliper half.
9. Install the anti-rattle spring (**Figure 55**) onto the boss on the outboard caliper half.
10. Make sure the O-rings are still in place and assemble the caliper body halves.
11. Install one of the caliper mounting bolts through the upper hole (A, **Figure 56**) to correctly align the caliper halves.
12. Install the two caliper body bolts (B, **Figure 56**) and tighten securely. They will be tightened to the specified torque after the caliper is installed on the front fork.
13. If removed, install the bleed valve assembly and tighten to 80-100 in.-lb. (9.0-11.3 N•m).
14. Install the caliper as described in this section.

FRONT MASTER CYLINDER (1986-1995 MODELS)

Review *Brake Service* in this chapter.
Refer to **Figure 57**.

Removal

1. Pull the rubber cover off of the front caliper bleed valve (**Figure 58**) and insert a hose onto the end of the valve. Insert the open end of the hose into a container. Open the front bleed valve and drain the brake fluid from the front brake assembly by operating the hand lever. Remove the hose and close the bleed valve after draining the assembly. Discard

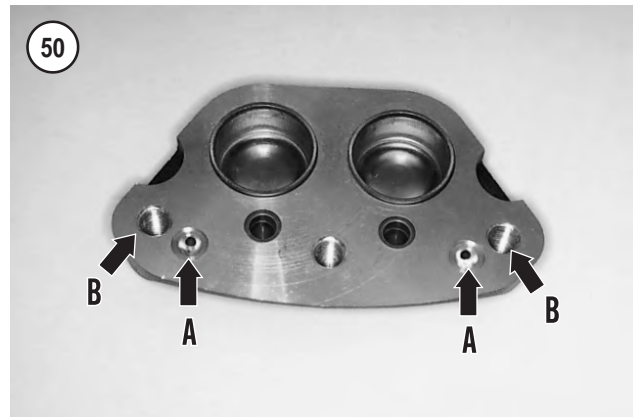

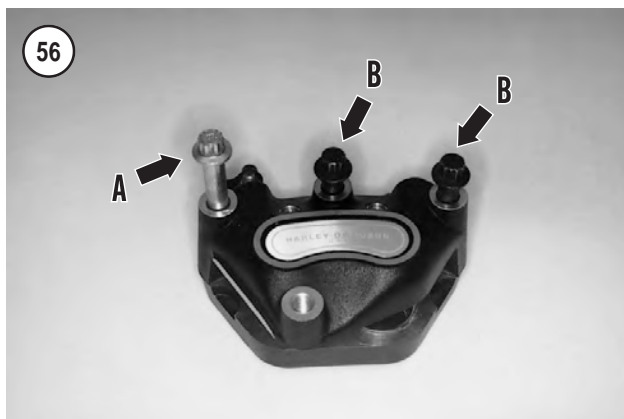
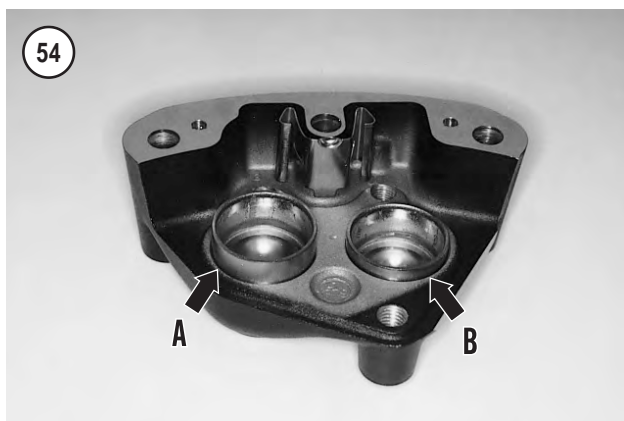

the brake fluid. Refer to *Brake Fluid Draining* in this chapter.

2. Place a couple of shop cloths under the banjo bolt and remove the banjo bolt and washers securing the brake hose to the master cylinder (A, **Figure 59**).
3. Remove the screws (B, **Figure 59**) securing the master cylinder to the handlebar and remove the master cylinder.

Installation

1. Position the master cylinder onto the handlebar and install the clamp and screws (B, **Figure 59**). Tighten the screws to 70-80 in.-lb. (8-9 N•m).
2. Install the brake hose onto the master cylinder and brake caliper. Be sure to place a *new* banjo bolt washer on each side of the hose fitting (A, **Figure 59**) when installing the banjo bolt. Tighten the banjo bolt to 17-22 ft.-lb. (23-30 N•m).
3. Fill the master cylinder with new DOT 5 brake fluid. Bleed the brake system as described in this chapter.
4. If necessary, loosen the clamp screws and reposition the master cylinder to suit the rider. Retighten the clamp screws to 70-80 in.-lb. (8-9 N•m).

Disassembly

1. Remove the master cylinder as described in this section.
2. If still in place, remove the screws securing the top cover and remove the cover and diaphragm.
3. Remove the brake lever assembly as follows:
 - a. Remove the snap ring from the pivot pin.
 - b. Push out the pivot pin and remove the brake lever assembly.
 - c. Remove the reaction pin (A, **Figure 60**) from the brake lever (B).
 - d. Remove the pushrod from the piston assembly.
4. Remove the piston assembly as follows:
 - a. Remove the dust boot (A, **Figure 61**).
 - b. Remove the piston and spring assembly (B, **Figure 61**).
5. If damaged, remove the grommet and sight glass from the master cylinder housing.

Assembly

- 1A. If installing the original equipment master cylinder rebuild kit, use the supplied lubricant to coat the master cylinder bore and piston components.
- 1B. If installing an aftermarket master cylinder rebuild kit, soak the piston O-ring and cup in new DOT 5 brake fluid prior to installation. Apply a thin coat of brake fluid to the cylinder bore prior to assembly.
2. Install the grommet and sight glass if removed.
3. Install the cup onto the small end of the spring.
4. Install the O-ring onto the piston.

57

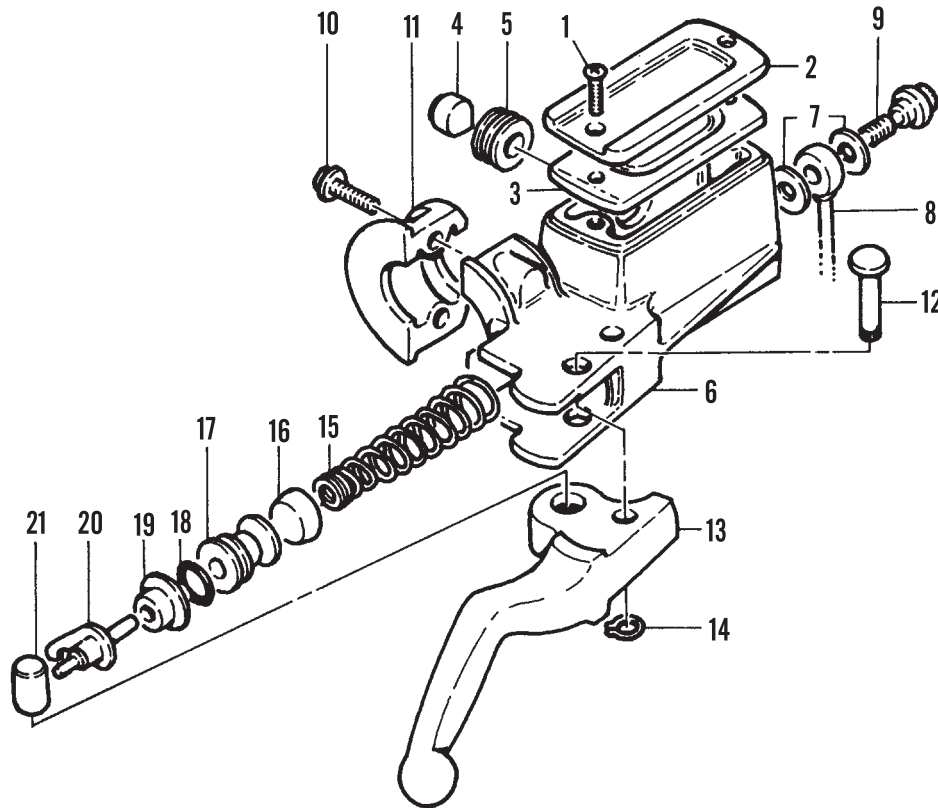
FRONT MASTER CYLINDER (1986-1995 MODELS)

- | | |
|--------------------|------------------------------|
| 1. Screw | 12. Pivot pin |
| 2. Cover | 13. Brake lever |
| 3. Diaphragm | 14. Snap ring |
| 4. Sight glass | 15. Spring |
| 5. Grommet | 16. Cup |
| 6. Reservoir/body | 17. Piston |
| 7. Sealing washers | 18. O-ring |
| 8. Brake hose | 19. Dust boot |
| 9. Banjo bolt | 20. Pushrod and brake switch |
| 10. Screw | 21. Reaction pin |
| 11. Clamp | |

58



59

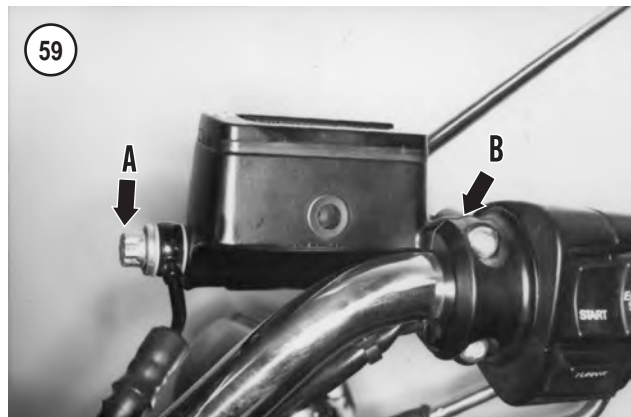

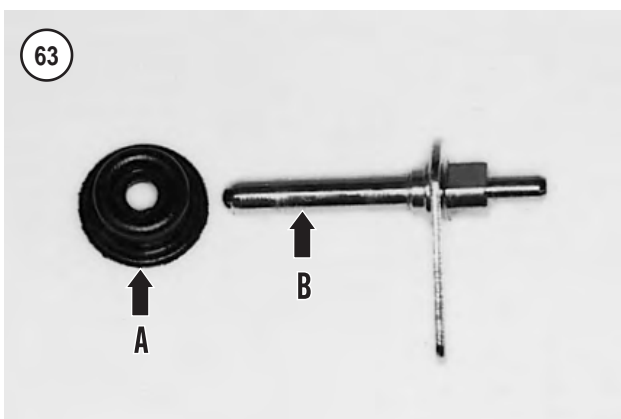
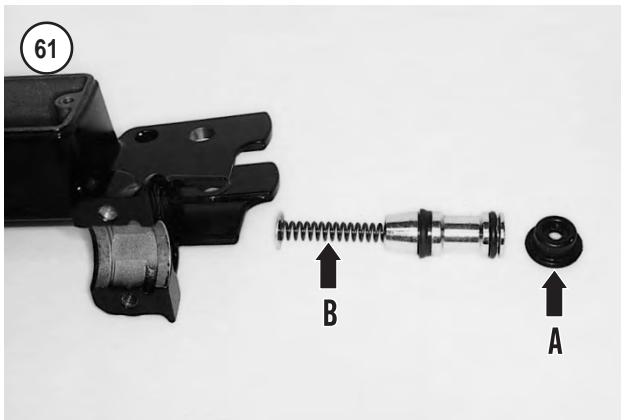
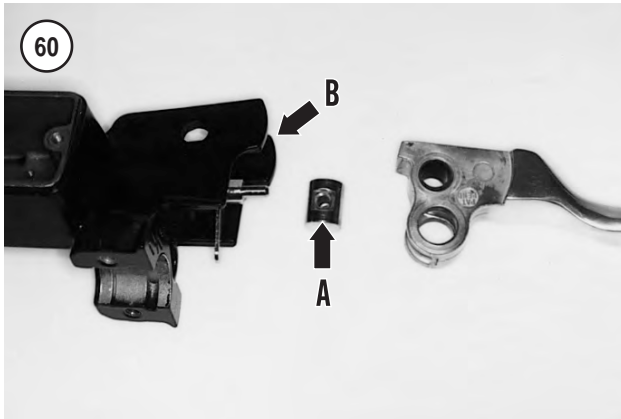

4. Position the spring with the wide end first and install the spring into the master cylinder.
5. Position the piston with the O-ring end going in last and install the piston into the master cylinder (**Figure 62**).
6. Slide the dust boot (A, **Figure 63**) onto the pushrod (B). Refer to **Figure 64**.
7. Assemble the brake lever as follows:

NOTE

Do not seat the dust boot into the master cylinder at this time.

- a. Slide the long end of the pushrod (**Figure 65**) into the piston with the dust boot facing the piston. Turn the pushrod so the arm faces the master cylinder.
- b. Apply a light coat of antiseize lubricant onto the reaction pin (A, **Figure 66**).
- c. Install the reaction pin (A, **Figure 66**) into the brake lever (B). Make sure the square pinhole (**Figure 67**) faces out.
- d. Slide the brake lever into the master cylinder and seat the end of the pushrod into the reaction pin hose (**Figure 68**). Hold the brake lever in this position. Install the pushrod arm into the cutout in the master cylinder.
- e. Slide the pivot pin through the master cylinder and brake lever pivot holes.

- f. Turn the master cylinder over and install the snap ring into the pivot pin groove. Make sure the snap ring is seated correctly in the groove.
 - g. Apply the brake lever once to seat the dust seal into the master cylinder bore (**Figure 69**).
8. Apply the brake lever several times. There must be no binding or excessive play. Make sure the pushrod is seated in the reaction pinhole (**Figure 69**). If the brake lever does not operate correctly, repeat this procedure and correct the problem.

WARNING

If the assembled pushrod and reaction pin are not operating correctly, the front master may cause the front brake to lock up and/or result in the complete loss of front brake operation.

Inspection

Replace worn or damaged parts as described in this section. A new piston kit should be installed every time the master cylinder is disassembled.

1. Clean all parts in new DOT 5 brake fluid or isopropyl alcohol. Inspect the body cylinder bore surface for signs of wear and damage. If it is less than perfect, replace the master cylinder assembly. The body cannot be replaced separately.
2. The piston assembly consists of the dust boot, O-ring, piston, cup and spring. Inspect the rubber parts for wear, cracks, swelling or other damage. Check the piston for wear or damage. If any one part of the piston assembly is damaged, replace the entire piston assembly as a kit.
3. Inspect the master cylinder bore for scratches or wear grooves.
4. Clean the vent hole in the cover if plugged.
5. Check the banjo bolt threads in the master cylinder. If the threads are slightly damaged, renew them using the properly sized thread tap. If the threads are severely worn or damaged, replace the master cylinder body.
6. Inspect the piston bore in the master cylinder for wear, corrosion or damage. Replace the master cylinder if necessary.

NOTE

If a tap is used to clean the threads in the master cylinder, flush the master cylinder thoroughly and blow dry.

7. Make sure the banjo bolt passage hole is clear.

**FRONT MASTER CYLINDER
(1996-2003 MODELS)**

Review *Brake Service* in this chapter.
Refer to **Figure 70**.

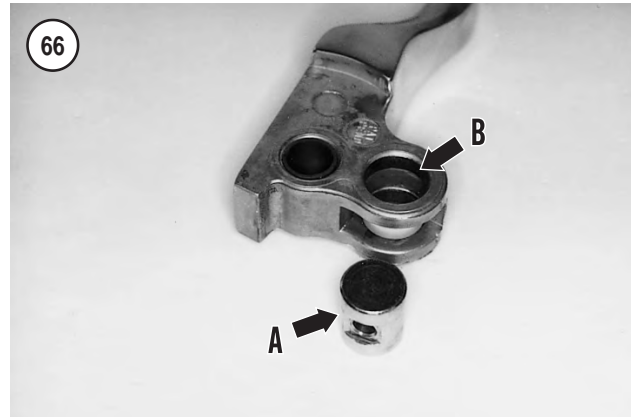

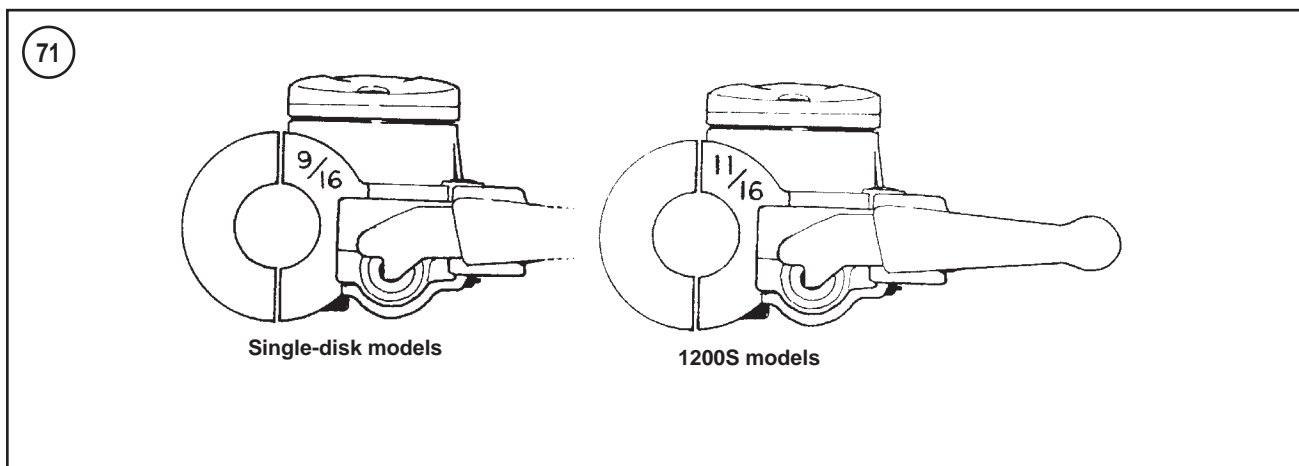
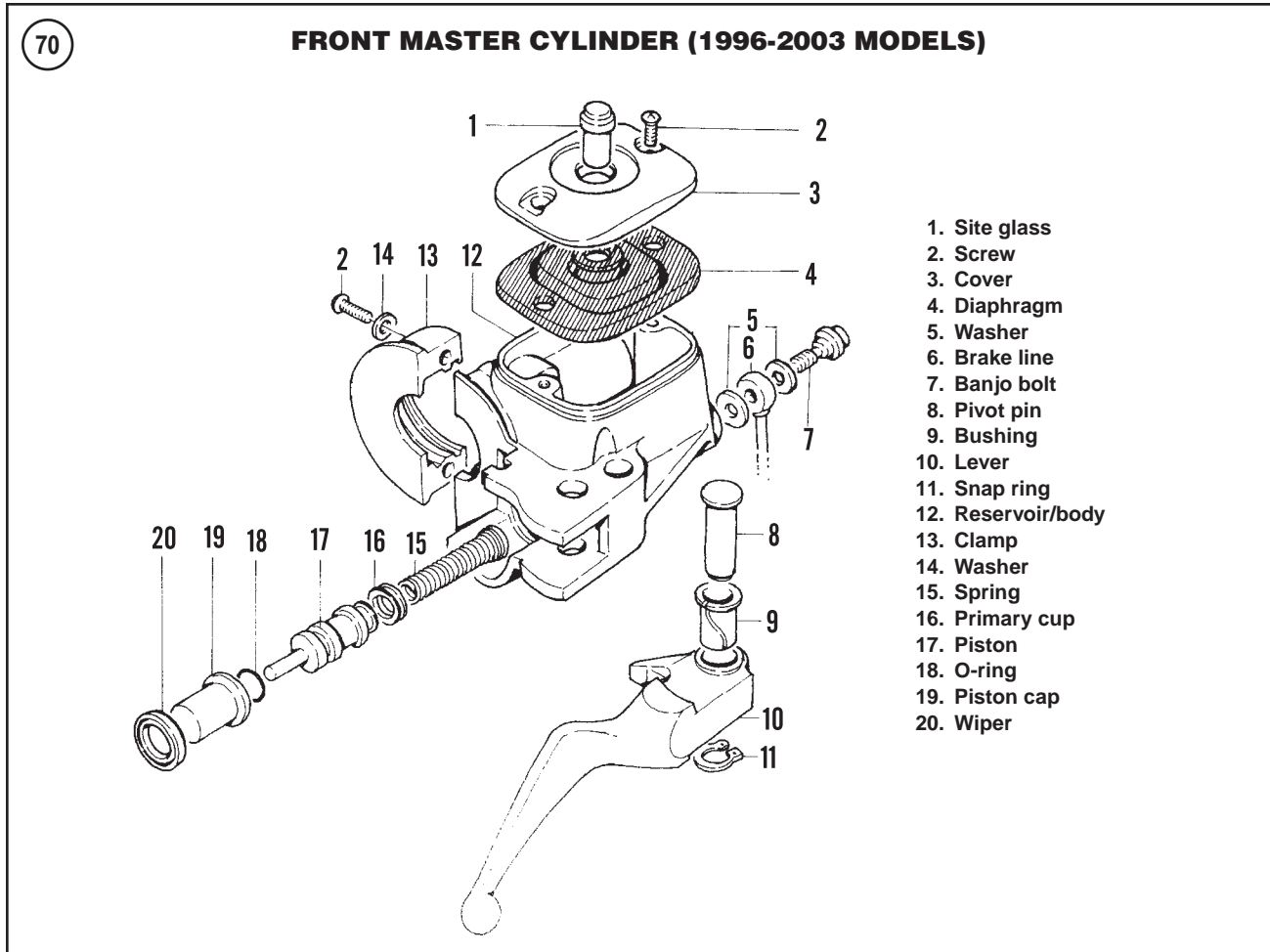

Identification

Two different master cylinders are used depending on the number of front disc brakes on the motorcycle. The master cylinder used with a single front brake disc has a smaller bore than the master cylinder used with dual brake discs.

A number cast into the master cylinder body (**Figure 71**) identifies the type of master cylinder. The number “9/16” identifies a master cylinder designed for single-disc operation.

The number “11/16” identifies a master cylinder designed for dual-disc operation.

Removal

1. Pull the rubber cover off the front caliper bleed valve (**Figure 72**) and insert a hose onto the end of the valve. Insert the open end of the hose into a container. Open the front

bleed valve and drain the brake fluid from the front brake assembly by operating the hand lever. Remove the hose and close the bleed valve after draining the assembly. Discard the brake fluid. Refer to *Brake Fluid Draining* in this chapter.

2. Clean the top of the master cylinder.

CAUTION

Failure to install the spacer in Step 3 will result in damage to the rubber boot and plunger on the front brake switch.

3. Insert a 5/32 in. (4 mm) thick spacer (A, **Figure 73**) between the brake lever and lever bracket. Make sure the spacer stays in place during the following steps.

4. Remove the banjo bolt (A, **Figure 74**) and sealing washers securing the brake hose to the master cylinder.

5. Place the loose end of the brake hose in a plastic bag to prevent fluid leaks and the entry of moisture and debris.

6. Remove the screw securing the right side handlebar switch together and separate the switch.

7. Remove the bolts and washers securing the clamp and master cylinder to the handlebar.

8. Remove the master cylinder assembly from the handlebar.

9. If necessary, remove the screws (B, **Figure 74**) securing the cover, then remove the cover (C) and diaphragm. Drain any residual brake fluid from the master cylinder and dispose of it properly.

10. If the master cylinder assembly is not going to be serviced, reinstall the clamp and bolts to the master cylinder. Place the assembly in a plastic bag to protect it from moisture and debris.

Installation

CAUTION

Failure to install the spacer between the brake lever and the brake spacer results in damage to the rubber boot and plunger on the front brake switch.

1. Insert the 5/32 in. (4 mm) thick spacer between the brake lever and lever bracket if not in place. Make sure the spacer stays in place during the following steps.

2. Position the front master cylinder onto the handlebar. Align the master cylinder notch (B, **Figure 73**) with the locating tab on the lower portion of the right side switch.

CAUTION

*Do not damage the front brake light switch and rubber boot (**Figure 75**, typical) when installing the master cylinder.*

3. Push the master cylinder all the way onto the handlebar (A, **Figure 76**). Hold it in this position and install the upper portion of the right side switch (B, **Figure 76**). Install the switch clamp screw and tighten it securely.

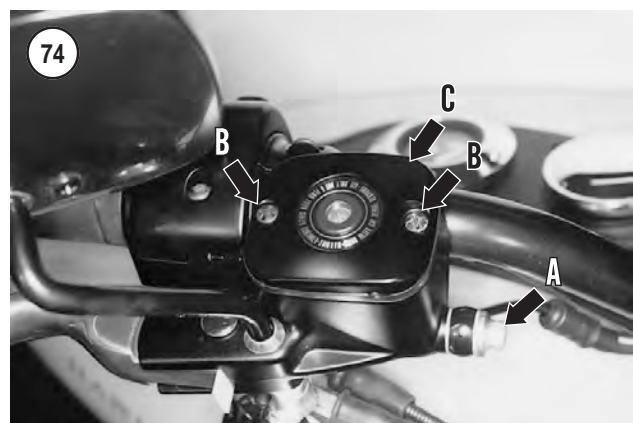
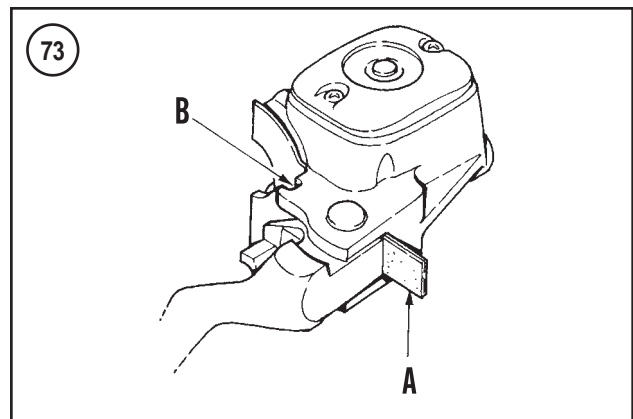

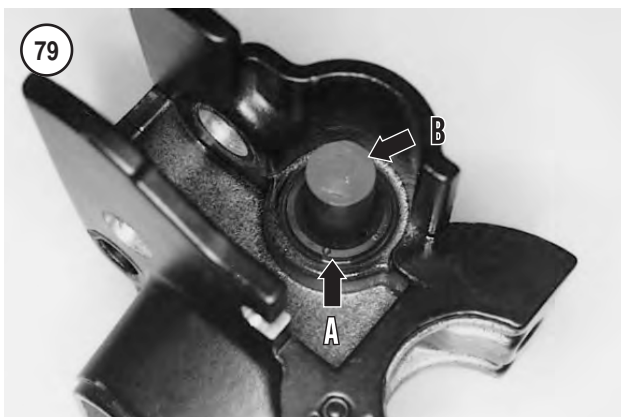
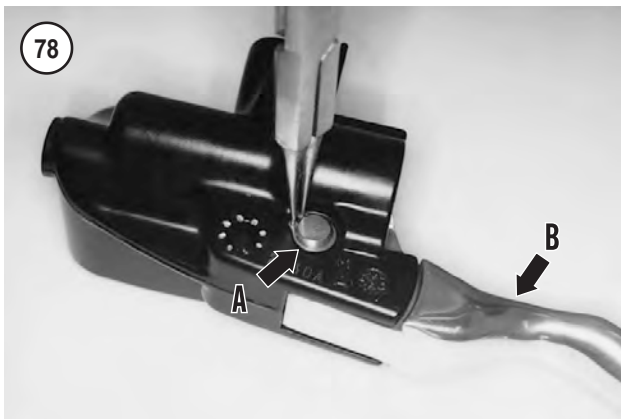
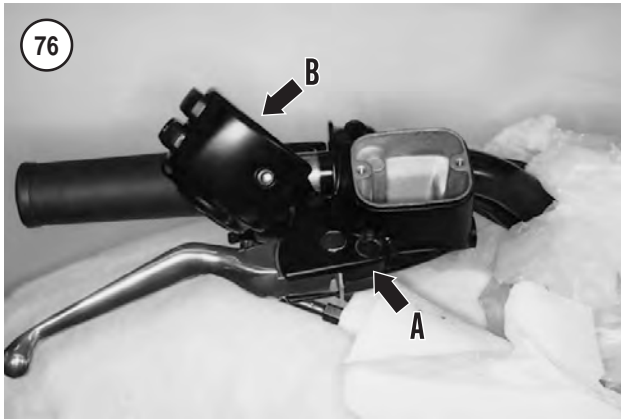

4. Position the clamp and install the bolts and washers. Tighten the upper mounting screw, then the lower screw. Tighten the screws to 70-80 in.-lb (8-9 N•m).
5. Apply new DOT 5 brake fluid to the rubber portions of the new sealing washers prior to installation.
6. Install new sealing washers and the banjo bolt (**Figure 77**) securing the brake hose to the master cylinder (**A, Figure 74**). Tighten the banjo bolt to 17-22 ft.-lb. (23-30 N•m).
7. Remove the spacer from the brake lever.
8. Refill the master cylinder reservoir and bleed the brake system as described in this chapter.

Disassembly

1. Remove the master cylinder as described in this section.
2. If still in place, remove the top cover and diaphragm.
3. Remove the snap ring (**A, Figure 78**) and pivot pin securing the hand lever to the master cylinder. Remove the hand lever (**B, Figure 78**).
4. Remove the retainer (**A, Figure 79**) and the rubber boot (**B**) from the area where the hand lever actuates the piston assembly.
5. Remove the piston assembly (**Figure 80**) and the spring.
6. Inspect all parts as described in this section.

Inspection

Replace worn or damage parts as described in this section. Install a new piston kit assembly every time the master cylinder is disassembled.

1. Clean all parts in new DOT 5 brake fluid or isopropyl alcohol. Inspect the body cylinder bore surface for signs of wear and damage. Replace the master cylinder assembly, if damaged. The body cannot be replaced separately.
2. Inspect the piston cup (**A, Figure 81**) and O-ring (**B**) for signs of wear and damage.
3. Make sure the fluid passage (**Figure 82**) in the bottom of the master cylinder reservoir is clear. Clean it out if necessary.

4. Inspect the piston contact surface for signs of wear and damage.
5. Check the end of the piston (C, **Figure 81**) for wear caused by the hand lever.
6. Check the hand lever pivot lugs in the master cylinder body for cracks or elongation.
7. Inspect the hand lever pivot hole and bushing (A, **Figure 83**), and the pivot pin (B) for wear, cracks or elongation.
8. Inspect the piston cap and retainer (**Figure 84**) for wear or damage.
9. Inspect the threads in the bore for the banjo bolt. If they are worn or damaged, clean them out with a thread tap or replace the master cylinder assembly.
10. Check the top cover and diaphragm for damage or deterioration.
11. If necessary, separate the cover from the diaphragm as follows:
 - a. Pull straight up on the sight glass (**Figure 85**) and remove it from the cover and diaphragm.
 - b. Separate the diaphragm from the cover.
 - c. The trim plate may separate from the cover.

Assembly

CAUTION

The cover and diaphragm must be assembled as described. If the sight glass is not installed correctly through the cover and diaphragm neck, brake fluid will leak past these components.

Refer to **Figure 71**.

- 1A. If installing the original equipment master cylinder rebuild kit, use the supplied lubricant to coat the master cylinder bore and piston components.
- 1B. If installing an aftermarket master cylinder rebuild kit, soak the piston O-ring in new DOT 5 brake fluid prior to installation. Apply a thin coat of brake fluid to the cylinder bore assembly.
2. If the cover and the diaphragm were disassembled, assemble them as follows:
 - a. Install the trim plate (**Figure 86**) onto the cover if it was removed.
 - b. Insert the neck of the diaphragm into the cover. Press it in until it seats correctly and the outer edges align with the cover.
 - c. Push the sight glass (**Figure 85**) straight down through the cover and the neck of the diaphragm (**Figure 87**) until it snaps into place. The sight glass must lock these two parts together to avoid leaks.
3. Soak the new cup, O-ring and piston assembly in new DOT 5 brake fluid for 15 minutes to make them pliable. Coat the inside of the cylinder bore with new brake fluid prior to the assembly of parts.

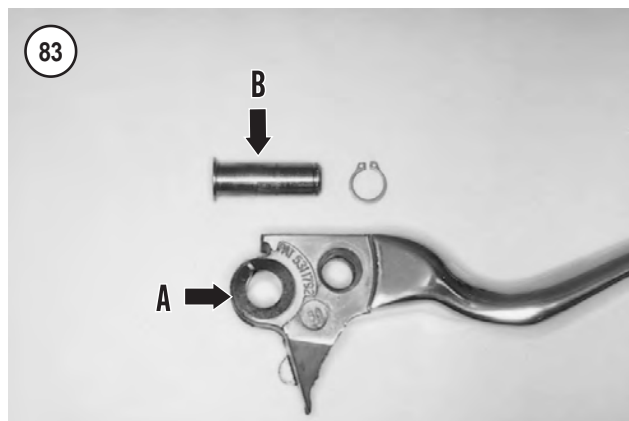
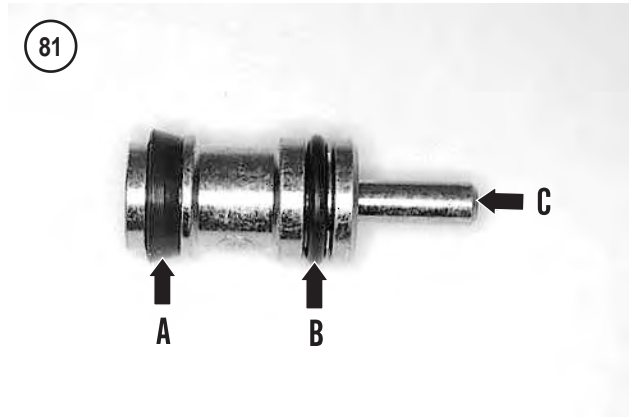



CAUTION

When installing the piston assembly, do not allow the cup to turn inside out as it will be damaged and allow brake fluid leaks within the cylinder bore.

4. Install the spring and piston assembly into the cylinder (**Figure 88**). Push them in until they bottom in the cylinder (**Figure 80**).
5. Position the retainer with the flat side going on first, and install the piston cap and retainer onto the piston end.
6. Push down on the piston cap (**Figure 89**). Hold it in place and press the retainer down until it correctly seats in the cylinder groove (A, **Figure 79**).
7. Make sure the bushing is in place in the hand lever pivot area.
8. Install the hand lever (B, **Figure 78**) into the master cylinder. Install the pivot pin and secure it with the snap ring. Make sure the snap ring is correctly seated in the pivot pin groove (A, **Figure 78**).
9. Apply the lever to make sure it pivots freely.
10. Install the master cylinder as described in this section.

REAR BRAKE PADS (1986-EARLY 1987 MODELS)

There is no recommended mileage interval for changing the brake pads. Pad wear depends on personal riding habits and the condition of the brake system. Inspect the rear brake pads for uneven wear, scoring, oil contamination or other damage. Replace the brake pads if the pad thickness is less than 0.062 in. (1.6 mm.).

Always replace the rear brake pads as a set.

Do not disconnect the brake hose from the caliper for brake pad replacement. Only disconnect the brake hose if removing the caliper.

Review *Brake Service* in this chapter.

90

REAR BRAKE CALIPER (1986-EARLY 1987 MODELS)

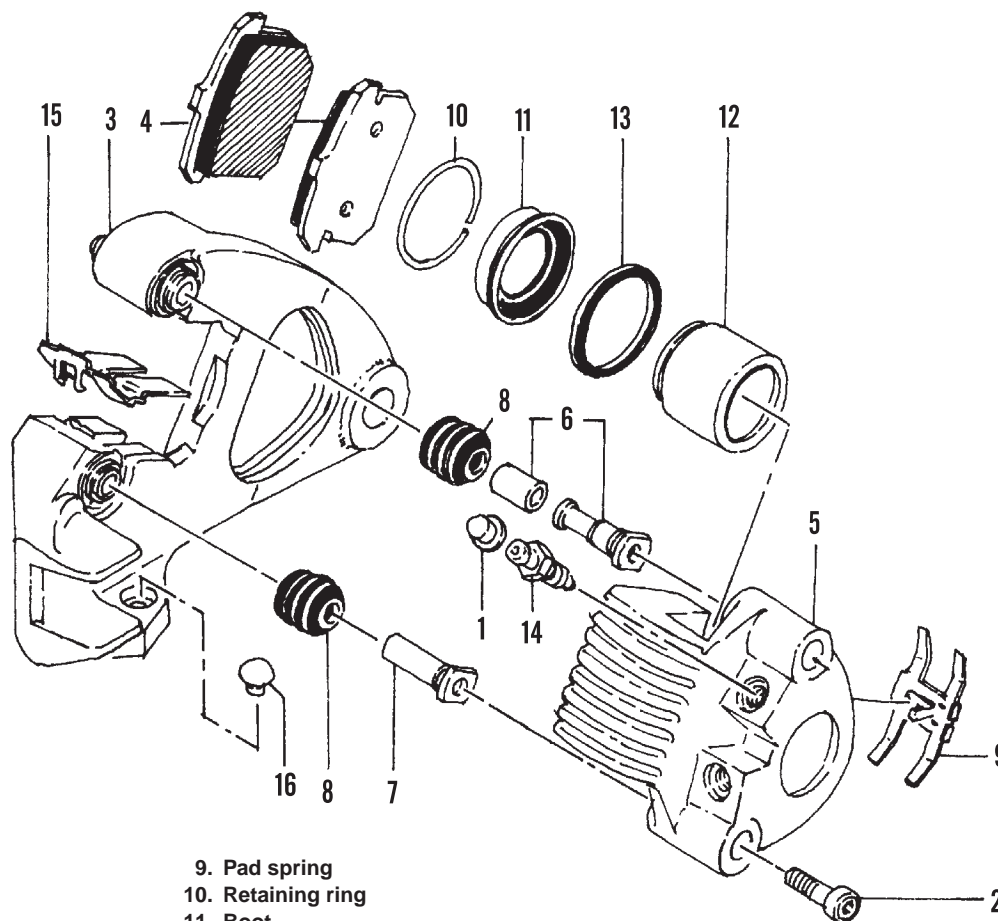

- | | |
|-----------------|--------------------|
| 1. Cap | 9. Pad spring |
| 2. Screw | 10. Retaining ring |
| 3. Frame | 11. Boot |
| 4. Pad | 12. Piston |
| 5. Caliper body | 13. Seal |
| 6. Upper pin | 14. Bleed valve |
| 7. Lower pin | 15. Abutment shim |
| 8. Boot | 16. Plug |

Replacement

Refer to **Figure 90**.

1. Tie the end of the brake pedal to the frame so it cannot be depressed. This prevents inadvertent application which may cause the pistons to be pushed out the caliper.
2. Remove the two caliper body mounting screws (**Figure 91**).
3. Pull the caliper body (5, **Figure 90**) away from the mounting frame (3).
4. Remove the pad spring (**Figure 92**) from inside the caliper.
5. Secure the caliper body to the motorcycle. Do not allow the caliper body to hang from the brake hose. Do not disconnect the brake line unless removing the caliper.

NOTE

If reusing the brake pads, mark each pad so it can be reinstalled in its original position in the caliper.

6. Slide the brake pads (**Figure 93**) off the frame.
7. Remove the upper and lower caliper pins. See **Figure 94**.
8. Check the abutment shims (**Figure 95**) in the caliper frame. If they are worn or damaged, replace as follows:
 - a. Pry the abutment shims away from the caliper. See **Figure 96**.
 - b. Remove all adhesive from the caliper surface where the abutment shims are located.
 - c. Clean the abutment shim surfaces with rubbing alcohol.

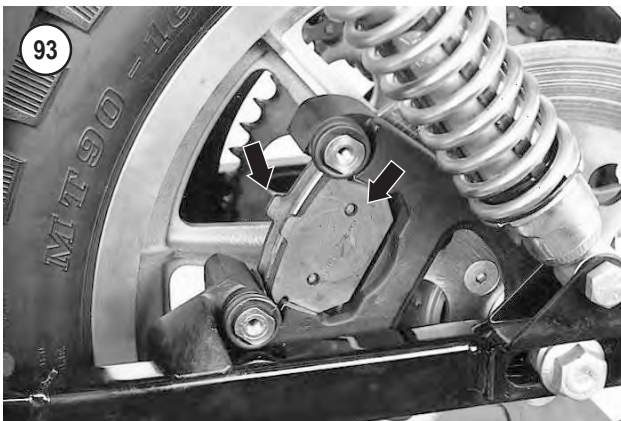
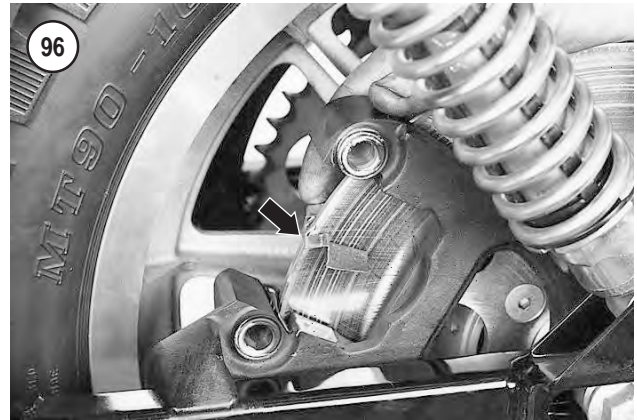
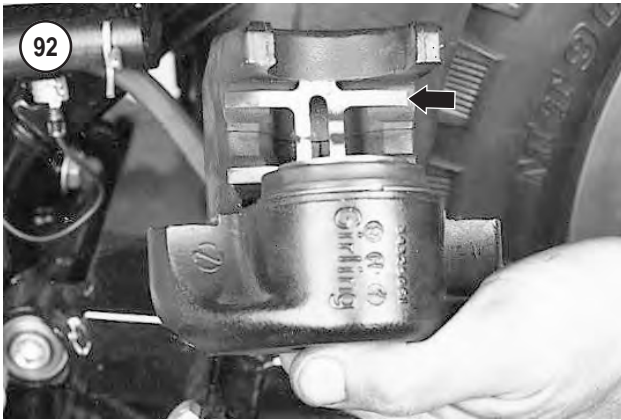
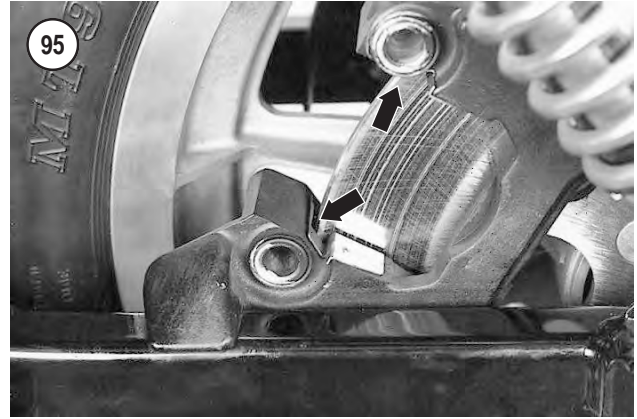

- d. Apply silicone sealant to the abutment shim surfaces on the caliper and install the abutment shims. Hold the shims in position by installing the brake pads (**Figure 93**) in the frame.
- e. Allow the silicone sealant to dry thoroughly before completing brake pad installation.
- f. Make sure the brake pads slide freely in the frame.

9. Check the brake pads (**Figure 97**) for wear or damage. Measure the brake pad thickness (**Figure 98**) and replace them if they are worn to 0.062 in. (1.6 in.).

10. Check the brake caliper for brake fluid leaks. If brake fluid has leaked from the caliper, rebuild it as described in this section.

11. Inspect the brake disc as described in this chapter.

12. Inspect the pins (A, **Figure 99**) for wear or damage. Check the boots (B, **Figure 99**) for tearing or deterioration. Replace worn or damaged parts if necessary.

13. Inspect the pin bushings (**Figure 100**) in the frame for wear or damage. Replace the frame assembly if the bushings are worn or damaged.

14. Install the boots onto the pin bushings. Then install the pin bushings in the frame. Insert the pin with the nylon sleeve into the top frame bushing (**Figure 94**). Fit the boots so they seat on the boss around the bushing holes.

CAUTION

If the boots are not seated properly, dirt can enter and cause rapid pin and bushing wear.

15. Turn the pins so the flats on the sides of the pins face as shown in **Figure 101**.

CAUTION

Do not allow the master cylinder to overflow. Brake fluid back flows to the reservoir as the pistons are pushed back into their bores. Because brake fluid damages most surfaces, immediately wash spilled brake fluid off surfaces it contacts. Use soapy water and rinse completely.

16. Remove the master cylinder cover (**Figure 102**) and diaphragm. Remove about 50% of the brake fluid in the reservoir. This prevents the master cylinder from overflowing when the pistons are compressed for pad installation. Do not drain more than 50% of the brake fluid, or air will enter the system. Discard fluid properly.

17. Push the piston (A, **Figure 103**) into the cylinder. Reinstall the master cylinder cover and diaphragm, but do not tighten the screws. The piston should move freely. If the piston is tight and there is evidence of sticking in the cylinder, remove and service the caliper as described in this section.

18. Install the pad spring (B, **Figure 103**) into the top of the caliper so the long tab on the spring extends above the piston. Hook the short tab on the spring above the ridge on the caliper casting opposite the piston. See **Figure 104**.

19. Install the brake pads (**Figure 93**) on the frame. Then install the caliper body over the brake pads and onto the bracket. Make sure the upper and lower pins (**Figure 101**) do not move when installing the caliper body.

20. Install the caliper screws (**Figure 91**) and tighten to 132-168 in.-lb. (15-19 N•m). Align the upper and lower pins as shown in **Figure 101**.

21. If tied to the frame, untie the rear brake pedal so it can be operated.



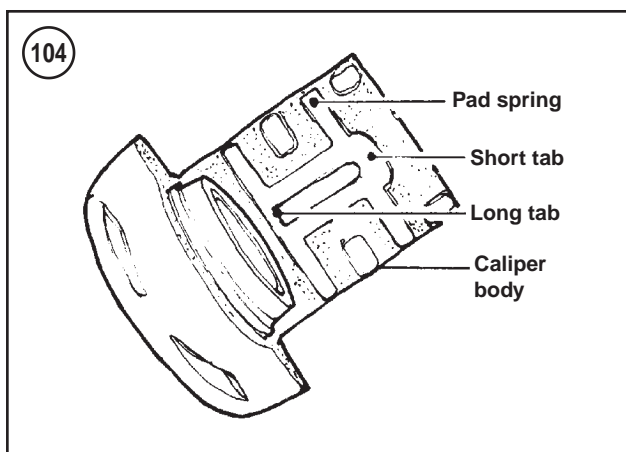
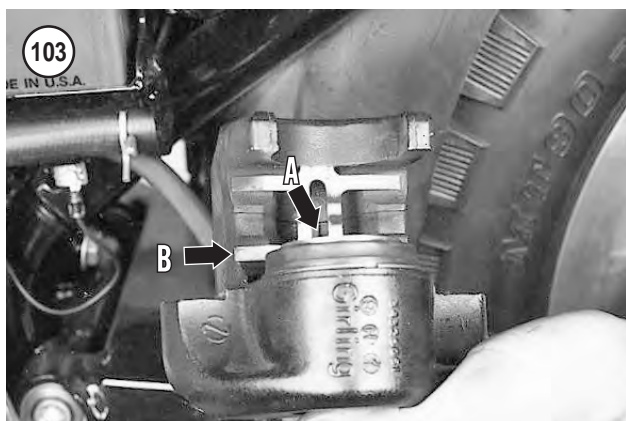

22. While the motorcycle is stationary with the engine off, apply the rear brake lever several times to seat the pads against the disc.

WARNING

Do not ride the motorcycle until the brakes are operating correctly. If necessary, bleed the brake as described in this chapter.

23. Bed the pads in gradually for the first 100 miles (160 km) by using only light pressure as much as possible. Immediate hard application glazes the new brake pads and greatly reduces their effectiveness.

REAR BRAKE PADS (LATE 1987-1999 MODELS)

There is no recommended mileage interval for changing the brake pads. Pad wear depends on personal riding habits and the condition of the brake system. Inspect the rear brake pads for uneven wear, scoring, oil contamination or other damage. Replace the brake pads if the pad thickness is less than 0.062 in. (1.6 in.).

Always replace the rear brake pads as a set.

Do not disconnect the brake hose from the caliper for brake pad replacement. Only disconnect the brake hose if removing the caliper.

Review *Brake Service* in this chapter.

Brake Pad/Pad Shim Identification

WARNING

When replacing brake pads, do not mix late 1987-early 1991 and late 1991-1999 brake pads and pad shims. Otherwise, improper rear brake operation will occur. This may cause brake failure and loss of control. When purchasing new brake pads, provide the dealership with the frame serial number for parts verification.

There was a design change between early 1991 and late 1991 models regarding the brake pads and pad shims (**Figure 105**). When purchasing replacement parts, note the following while referring to **Figure 106** (late 1987-early 1991 models) or **Figure 107** (late 1991-1999 models):

1A. On late 1987-early 1991 models, the pad shim thickness is 0.015 in. (0.38 mm).

1B. On late 1991-1999 models, the pad shim thickness is 0.030 in. (0.76 mm).

2A. On late 1987-early 1991 models, the pad shims have a tab in the middle of each long side.

2B. On late 1991-1999 models, the pad shims have an open loop at one end of the shim.

3A. On late 1987-early 1991 models, the brake pads measure approximately 3.44 in. (87.4 mm) as shown in **Figure 106**.

3B. On late 1991-1999 models, the brake pads measure approximately 3.39 in. (86.1 mm) as shown in **Figure 107**.

4. On late 1987-early 1991 models, the outboard brake pads have an angle-cut, half-size insulator mounted on the back of the pad. The inboard brake pad has a full-size insulator.

5. On late 1991-1999 models, the brake pads have full-size insulators mounted on the back of each pad.

Replacement

Refer to **Figure 105**.

1. Tie the end of the brake pedal to the frame so it cannot be depressed. This prevents inadvertent application which may cause the piston to be pushed out of the caliper.

105

REAR BRAKE CALIPER (LATE 1987-1999 MODELS)

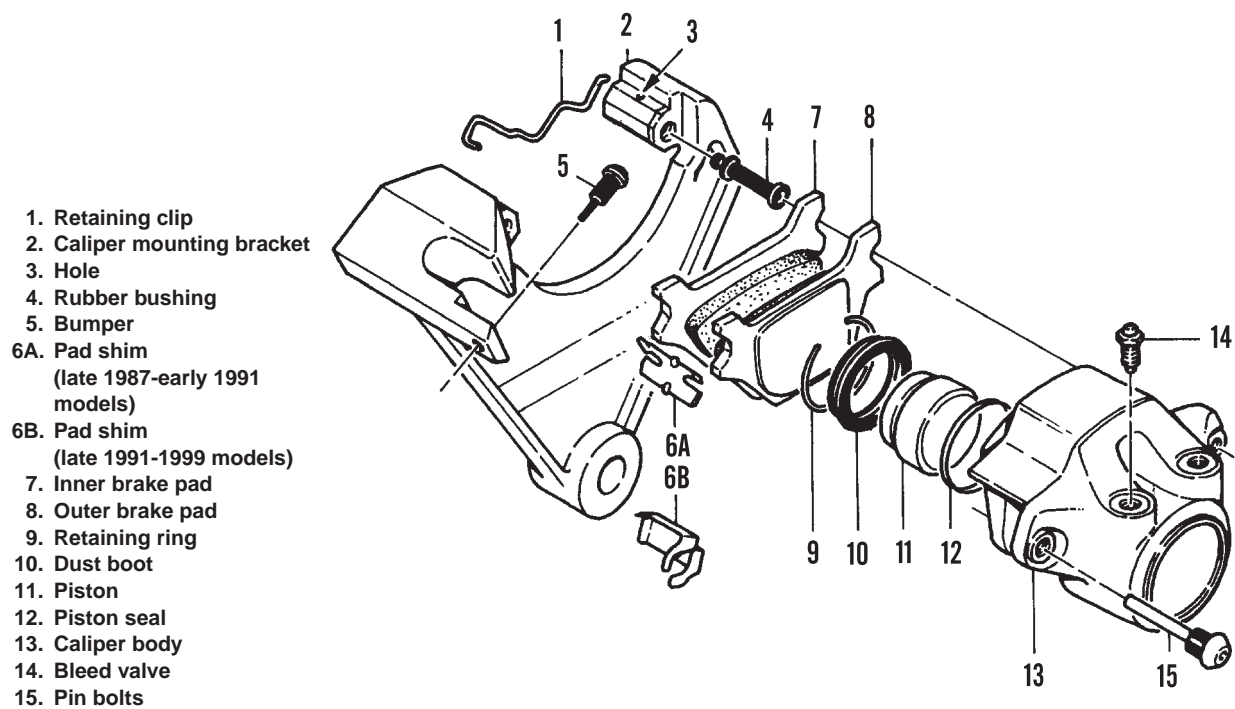

106

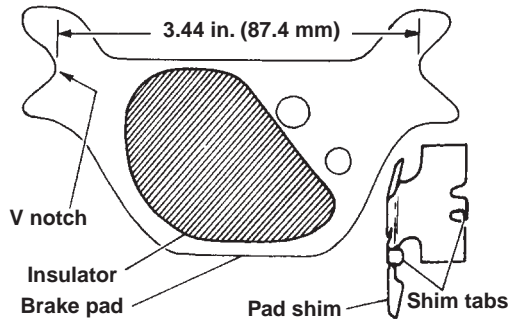

107

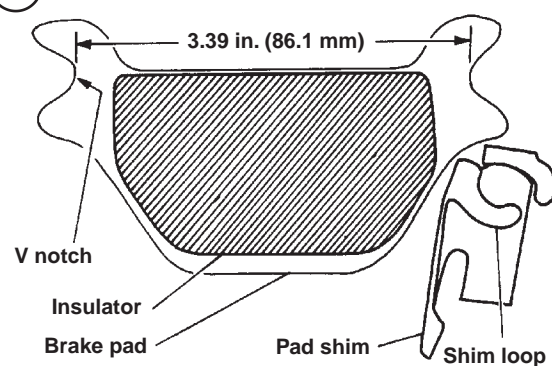

2. Remove the two caliper pin bolts (A, **Figure 108**) and lift the caliper (B) off the mounting bracket.

3. Secure the caliper to the motorcycle. Do not let it hang from the brake hose. Do not disconnect the brake line unless removing the caliper.

4. Pull the retainer clip (**Figure 109**) over the mounting bracket and remove it. See **Figure 110**.

NOTE

If reusing the brake pads, mark each pad so it can be reinstalled in its original mounting position in the caliper.

5. Remove the outer brake pad (**Figure 111**).

6. Remove the inner brake pad (A, **Figure 112**).

7. Remove the two pad shims (B, **Figure 112**) from the mounting bracket. Refer to **Figure 105** for a comparison of the late 1987-early 1991 models and late 1991-1999 models pad shims.

8. Check the brake pads (**Figure 113**) for wear or damage. Replace the brake pads if they are worn to 0.062 in. (1.6 mm) or less. Replace both pads as a set.

9. Clean the pad shims thoroughly and check for cracks or damage. Replace if necessary.

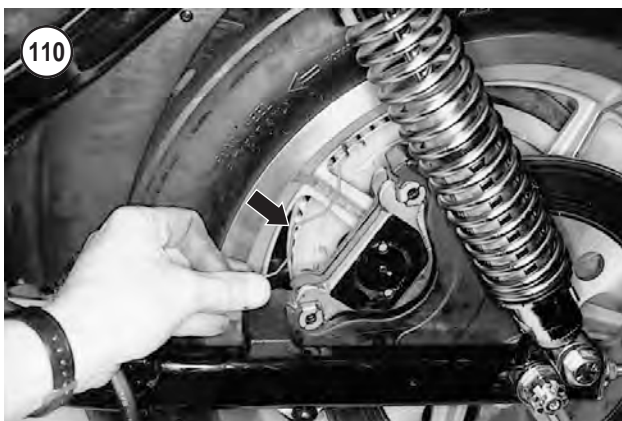
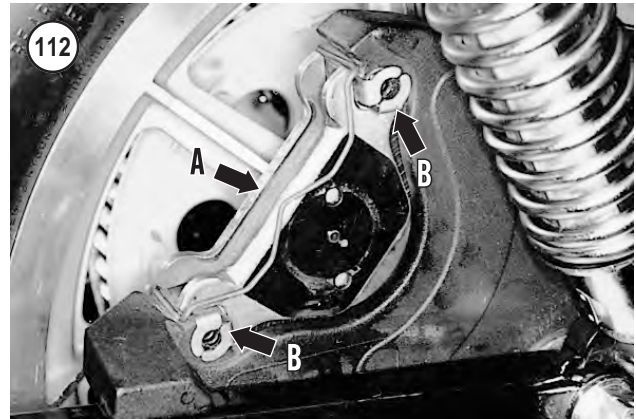
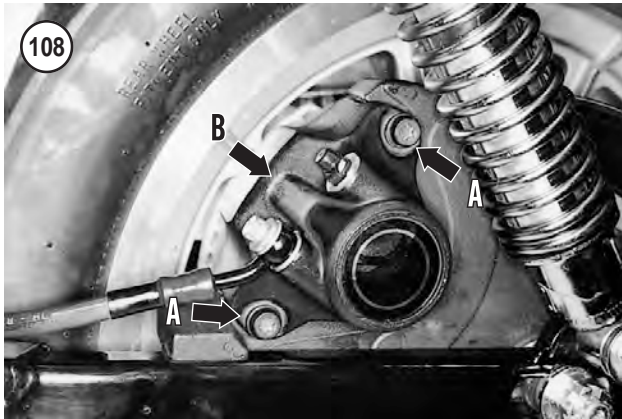

10. Clean the pad shim mounting area on the mounting bracket thoroughly.

11. Check the retainer clip. If worn, cracked, rusted, deformed or corroded, replace it.

12. Inspect the caliper pin bolts and replace if cracked, corroded or otherwise damaged.

13. Check the piston dust boot. If the boot is swollen or cracked or if brake fluid is leaking from the caliper bore, remove the rear caliper and overhaul it as described in this chapter.

14. Inspect the brake disc for wear as described in *Brake Disc* in this chapter.

CAUTION

Do not allow the master cylinder to overflow. Brake fluid back flows to the reservoir as the pistons are pushed back into their bores. Because brake fluid damages most surfaces, immediately wash spilled brake fluid off surfaces it contacts. Use soapy water and rinse completely.

15. Push the piston into the caliper cylinder. The piston should move freely. If not, and there is evidence of it sticking in the caliper bore, remove the rear caliper and service it as described in this chapter.

16. Reinstall the diaphragm and cover but do not install the cover screws.



NOTE

When replacing the brake pads and pad shims, refer to **Brake Pad/Pad Shim Identification** in this section. Confirm that you have the correct brake pad and pad shim assembly for your model.

17. Install the pad shims onto the caliper mounting bracket rails as follows:

- a. On late 1987-early 1991 models, insert the pad shim tabs (**Figure 106**) into caliper bracket shim holes (3, **Figure 105**).
- b. On late 1991-1999 models, install the pad shims so that their retaining loops face against the outer caliper mounting bracket rails as shown in B, **Figure 112** and **Figure 114**.
- c. On all models, hold the pad shims in place when installing the rear brake pad in Step 18.

NOTE

On late 1987-early 1991 models, the outboard brake pad is different from the inboard brake pad. The outboard brake pad (piston side) has an angle-cut, half-size insulator mounted on the back of the pad (**Figure 106**). The inboard brake pad has a full-size insulator.

NOTE

On late 1991-1999 models, install used pads in their original mounting positions as identified during removal. New pads are identical and can be installed in either position (inboard or outboard).

18. Slide the inboard brake pad (A, **Figure 112**) over the pad shims so that it contacts the inner brake disc surface. Check that the pad shims did not move out of position.

19. Slide the outboard brake pad (**Figure 111**) over the pad shims so that it contacts the outer brake disc surface.

20. Make sure the pad shims did not move out of position.

21. Insert the ends of the retainer clip (**Figure 110**) into the two holes in the backside of the caliper mounting bracket

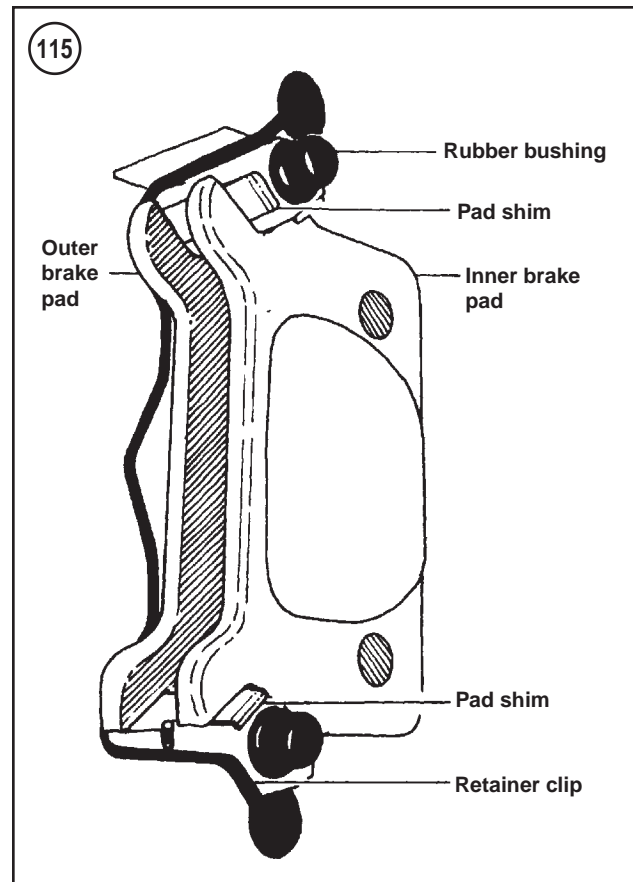

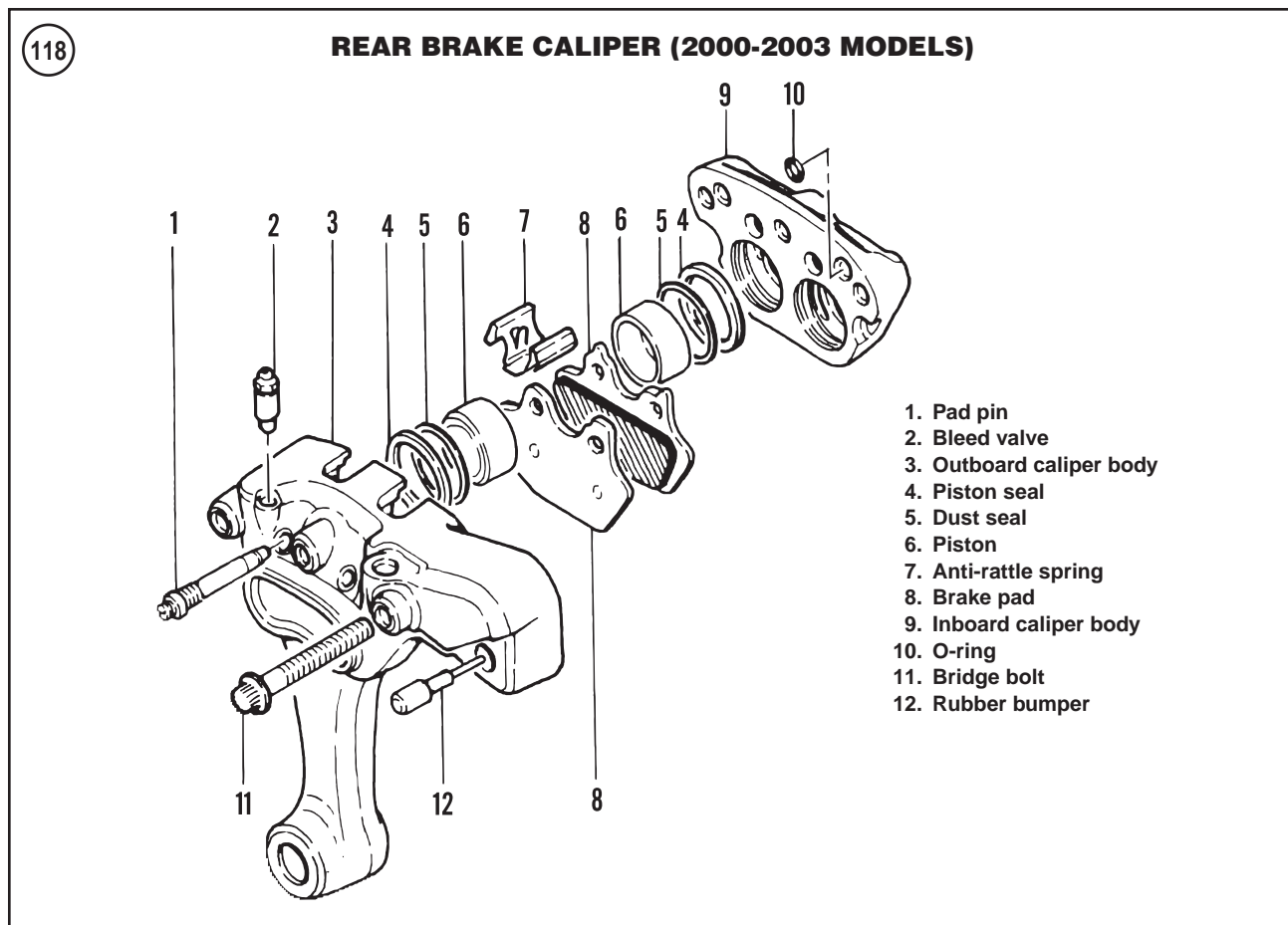

(Figure 115). Then pivot the clip over the top of the brake pads and snap it in place against the outer brake pad as shown in Figure 109.

CAUTION

After installing the retainer clip, check that both brake pads are still contacting the two pad shims; see Figure 116, typical. If the pads or shims are installed incorrectly, the rear brake will drag and cause uneven pad wear and caliper mounting bracket damage.

NOTE

The caliper should be installed over the brake pads so it does not knock against the brake pads and dislodge the pad shims.

22. Align the caliper with the brake pads and install it onto the pads (B, Figure 108). Align the caliper holes with the caliper mounting bracket threaded holes and install the two pin bolts. See Figure 117 and A, Figure 108. Start the bolts by hand, then tighten to 15-20 ft.-lb. (20-27 N•m).

23. If tied to the frame, untie the rear brake pedal so it can be operated.

24. Refill the master cylinder reservoir.

25. While the motorcycle is stationary with the engine off, apply the rear brake lever several times to seat the pads against the disc.

WARNING

Do not ride the motorcycle until the brakes are operating correctly. If necessary, bleed the brake as described in this chapter.

26. Bed the pads in gradually for the first 100 miles (160 km) of riding by using only light pressure as much as possible. Immediate hard application glazes the new brake pads and greatly reduces their effectiveness.

REAR BRAKE PADS (2000-2003 MODELS)

There is no recommended mileage interval for changing the brake pads in the rear brake caliper. Pad wear depends on personal riding habits and the condition of the brake system. Inspect the rear brake pads for uneven wear, scoring, oil contamination or other damage. Replace the brake pads if the pad thickness is less than 0.062 in. (1.6 in.).

Always replace the rear brake pads as a set.

Do not disconnect the brake hose from the caliper for brake pad replacement. Only disconnect the brake hose if removing the caliper.

Review *Brake Service* in this chapter.

Refer to Figure 118.

Replacement

1. Tie the end of the brake pedal to the frame so it cannot be depressed. This prevents inadvertent application which may cause the piston to push out of the caliper.
2. Clean the top of the master cylinder.
3. Remove the screws securing the cover and remove the cover (**Figure 119**) and diaphragm.
4. Remove about 50 percent of the brake fluid from the reservoir. This prevents the master cylinder from overflowing when the pistons are compressed for reinstallation. Do not drain more than 50 percent of the brake fluid or air will enter the system.
5. Loosen the pad pin bolts (**Figure 120**).

CAUTION

Do not allow the master cylinder to overflow. Brake fluid back flows to the reservoir as the pistons are pushed back into their bores. Because brake fluid damages most surfaces, immediately wash spilled brake fluid off surfaces it contacts. Use soapy water and rinse completely.

CAUTION

The brake disc is thin and easily damaged. When pushing against the disc in the following step, support the disc adjacent to the caliper to prevent damage.

6. Hold the caliper body from the outside and push it toward the brake disc. This pushes the outer pistons into the caliper bores to make room for the new brake pads. Constantly check the master cylinder reservoir to make sure brake fluid does not overflow. Remove fluid, if necessary, prior to it overflowing. Install the diaphragm and cover. Tighten the screws finger-tight.
7. Remove the pad pins (**Figure 120**).

NOTE

If reusing the brake pads, mark each pad so it can be reinstalled in its original position in the caliper.

8. Remove the inboard and outboard brake pads from the caliper.
9. Check the brake pads for wear or damage. Measure the thickness of the brake pad friction material. Replace the brake pads if they are worn to 0.062 in. (1.6 mm).
10. Clean the pad pins.
11. Check the friction surface of the new pads for any debris or manufacturing residue. If necessary, clean the pads with an aerosol brake cleaner.

NOTE

When purchasing new pads, check with the dealer to make sure the friction compound of the new pad is compatible with the disc material. Remove any roughness from the backs of

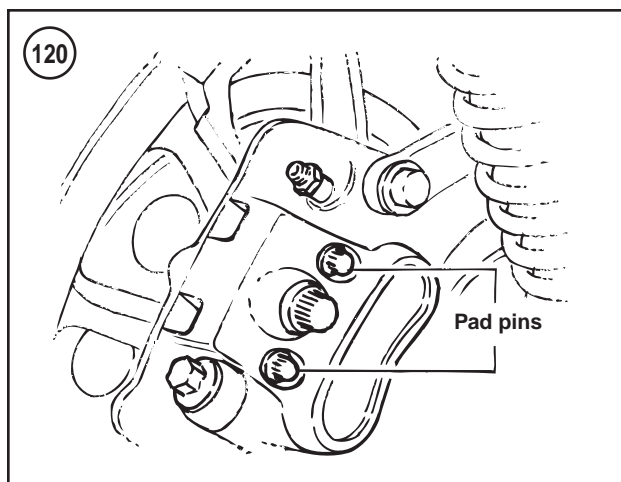
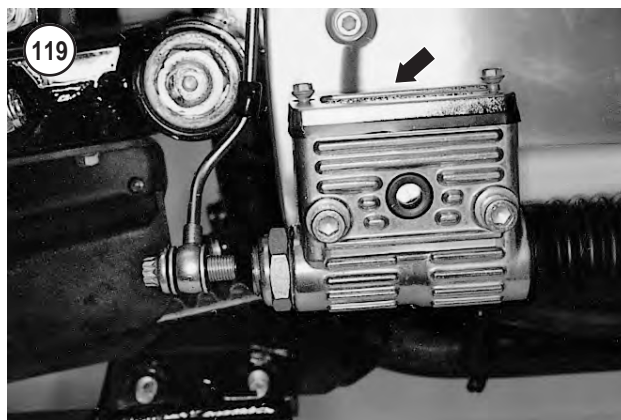

the new pads with a fine-cut file, then thoroughly clean them off.

NOTE

*The brake pads are not symmetrical. The pad with one tab (A, **Figure 121**) must be installed on the outboard side. The pad with two tabs (B, **Figure 121**) must be installed on the inboard side of the caliper.*

12. Install the outboard pad into the caliper.
13. Hold the pad in place and install the pad pin bolts part way in to hold the outboard pad in place.
14. Install the inboard pad into the caliper.
15. Push the pad pin bolts through the inboard pad and tighten to 180-204 in.-lb. (20-23 N•m).
16. If tied to the frame, untie the rear brake pedal so it can be operated.
17. Refill the master cylinder reservoir.
18. While the motorcycle is stationary with the engine off, apply the rear brake several times to seat the pads against the disc.

WARNING

Do not ride the motorcycle until the brakes are operating correctly. If necessary, bleed the brake as described in this chapter.

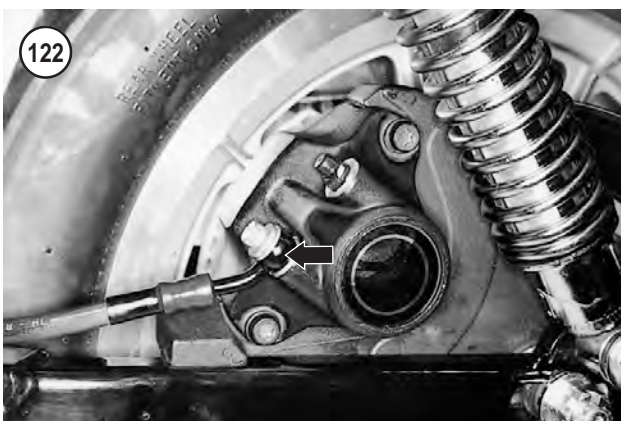
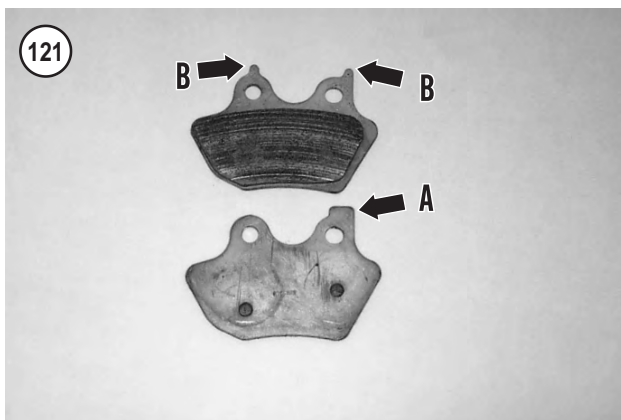

19. Bed the pads in gradually for the first 100 miles (160 km) of riding by using only light pressure as much as possible. Immediate hard application glazes the new friction pads and greatly reduces their effectiveness.

REAR BRAKE CALIPER (1986-EARLY 1987 MODELS)

Review *Brake Service* in this chapter.

Removal/Installation

NOTE

If the caliper is being removed for rear wheel service, proceed to Step 3.

1. Drain the brake fluid as described in this chapter.
2. Remove the brake line fitting (**Figure 122**, typical). Account for any washers. Plug the end of the hose and pace it in a plastic bag to prevent leaks and hose contamination.
3. Remove the brake pads as described in this chapter.

NOTE

If the caliper is being removed for rear wheel service, insert a spacer block between the piston and the opposite side of the caliper to prevent the piston from being pushed out of the bore if the brake pedal is accidentally de-

pressed. Suspend the caliper from the frame. Do not let the caliper hang from the brake line.

4. If the caliper is not going to be serviced, place it in a plastic bag to keep it clean.
5. To install, reverse the removal steps. Tighten the banjo bolt to 17-22 ft.-lb. (23-30 N•m).

Disassembly

The manufacturer does not provide specifications for wear limits on any of the rear caliper components except brake pads. Replace any parts that appear to be worn or damaged.

Refer to **Figure 123**.

1. Pry the retaining ring out of the caliper with an awl or small screwdriver.
2. Remove the piston boot.

WARNING

Compressed air forces the piston out of the caliper body with considerable force. Do not try to cushion the piston by hand as injury could result.

3. Position a wood block and shop rag in the caliper as shown in **Figure 124**. Gradually apply compressed air through the brake line port and remove the piston.
4. Remove the piston seal from the caliper bore.
5. If necessary, remove the bleed valve.
6. Inspect the caliper as described in this section.

Inspection

1. Clean the caliper body and piston in new DOT 5 brake fluid or isopropyl alcohol and dry with compressed air.
2. Make sure the fluid passageways in the piston bores are clear. Apply compressed air to the openings to make sure they are clear. Flush the passageways, if necessary, with new brake fluid.
3. Make sure the fluid passageways in the caliper body are clear. Apply compressed air to the opening to make sure it is clear. Flush the passageway, if necessary, with new brake fluid.
4. Inspect the piston ring retaining clip groove. Replace the caliper if the groove is damaged.
5. Inspect the brake hose threaded hole in the caliper body. If worn or damaged, renew with the correct size thread tap or replace the caliper body.
6. Inspect the bleed valve threaded hole in the caliper body. If worn or damaged, renew with the correct thread tap or replace the caliper body.
7. Inspect the bleed valve. Apply compressed air to the opening and make sure it is clear. Flush out, if necessary, with clean brake fluid. Install the bleed valve securely.
8. Inspect the piston. Clean it with new brake fluid. If it cannot be cleaned with brake fluid and a soft rag, replace the piston.
9. Inspect the piston bore. Replace if damage is found.

123

REAR BRAKE CALIPER (1986-EARLY 1987 MODELS)

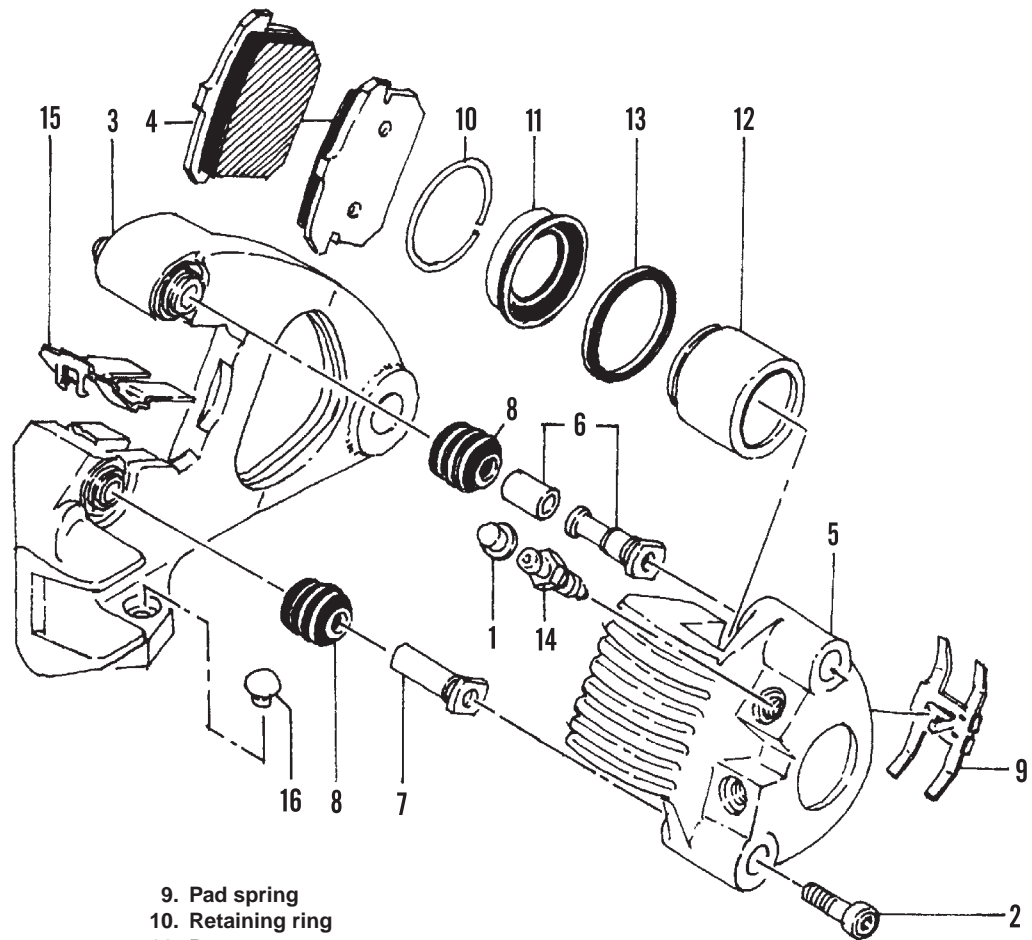

- | | |
|-----------------|--------------------|
| 1. Cap | 9. Pad spring |
| 2. Screw | 10. Retaining ring |
| 3. Frame | 11. Boot |
| 4. Pad | 12. Piston |
| 5. Caliper body | 13. Seal |
| 6. Upper pin | 14. Bleed valve |
| 7. Lower pin | 15. Abutment shim |
| 8. Boot | 16. Plug |

10. Never reuse the piston boot or seal. Replace the piston boot and seal during assembly.

Assembly

- Coat the following parts with new DOT 5 brake fluid:
 - Piston.
 - Piston boot.
 - Piston seal.
- Install the piston seal into the caliper bore.
- Align the piston with the piston bore and install it. Press the piston in all the way.
- Install the front piston boot.
- Install a new retaining ring so that it seats completely in the groove and presses against the piston dust boot.

124

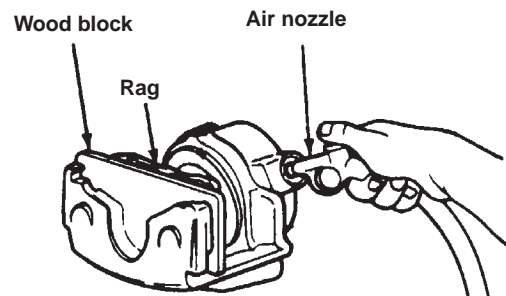



6. If removed, install the pad spring.
7. Install the brake pads as described in this chapter.

REAR BRAKE CALIPER (LATE 1987-1999 MODELS)

Review *Brake Service* in this chapter.

Removal

NOTE

If the caliper is being removed for rear wheel service, do not remove the brake line as noted in Step 1.

1. Loosen and remove the banjo bolt from the caliper (A, **Figure 125**). Remove the bolt and the two washers. Plug the open hose end in a plastic bag to prevent leaks and to keep out contamination.
2. Remove the two caliper pin bolts (B, **Figure 125**) and lift the caliper off the mounting bracket.

NOTE

If the caliper is being removed for rear wheel service, insert a wooden or plastic spacer block between the piston and the opposite side of the caliper to prevent the piston from being pushed out of the bore. Suspend the caliper from the frame. Do not hang the caliper from the brake hose.

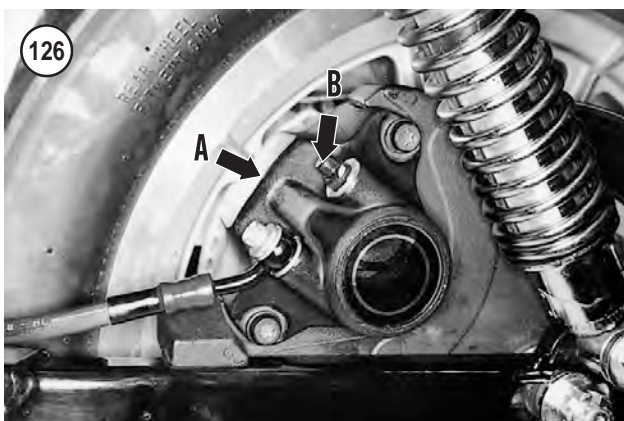

3. If the brake caliper is not going to be serviced, place it in a plastic bag to keep it clean.

Installation

1. If removed, install the brake pads as described in this chapter.
2. Align the caliper (A, **Figure 126**) with the brake pads and install it over the pads. Align the caliper holes with the caliper mounting bracket threaded holes and install the two pin bolts. See **Figure 117** and B, **Figure 125**. Start the bolts by hand, then tighten to 15-20 ft.-lb. (20-27 N•m).
3. Tighten the bleed valve (B, **Figure 126**) if it was previously loosened.
4. If removed, assemble the brake line onto the caliper by placing a *new* washer (**Figure 127**) on both sides of the brake line fitting (**Figure 128**), then secure the fitting to the caliper with the banjo bolt (A, **Figure 125**). Tighten the banjo bolt to 17-22 ft.-lb. (23-30 N•m).
5. Bleed the brakes as described in this chapter.
6. While the motorcycle is stationary with the engine off, press the rear brake pedal several times to seat the pads against the disc.

WARNING

Do not ride the motorcycle until the brakes are operating correctly.



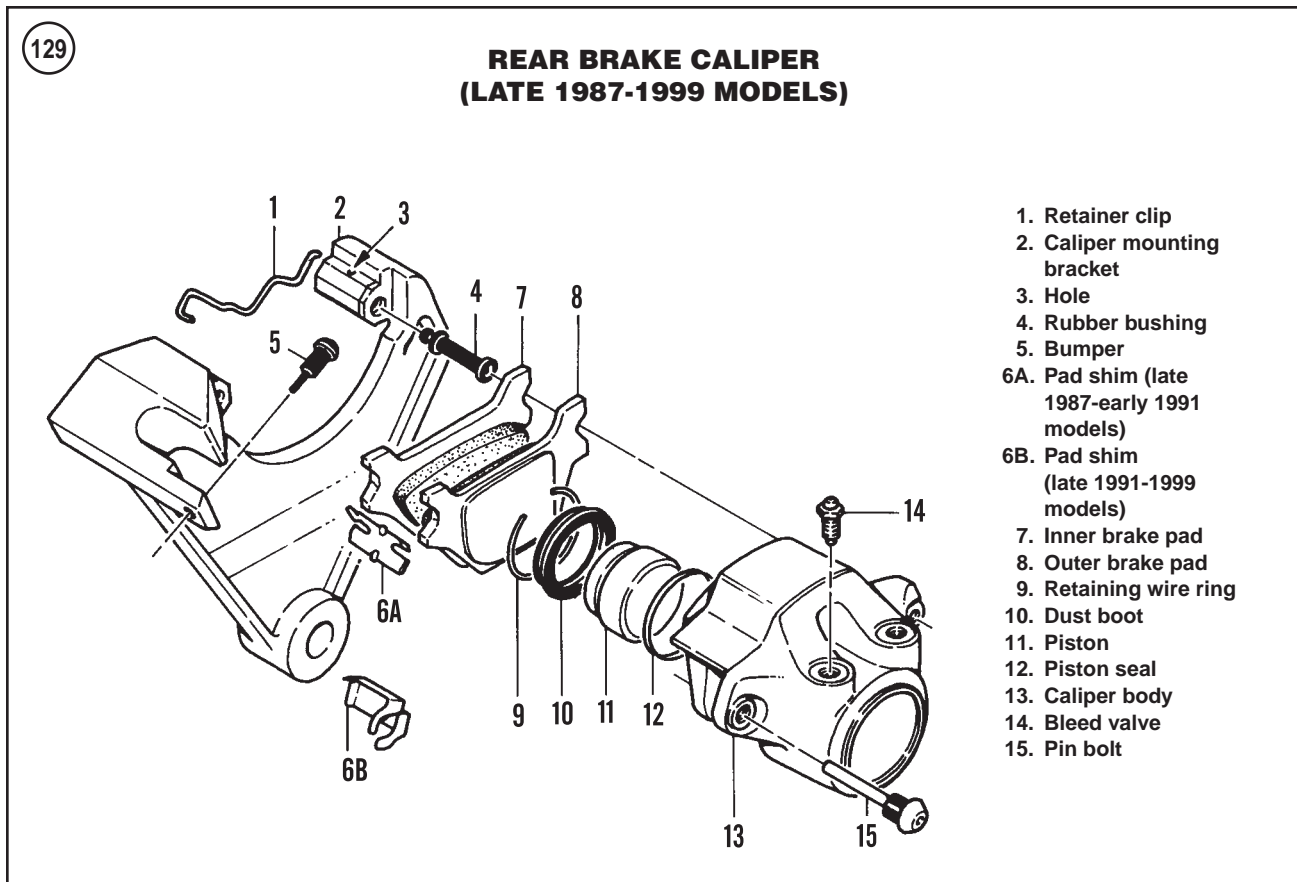

7. Bed the pads in gradually for the first 10 miles (160 km) by using light pressure as much as possible. Immediate hard application glazes new brake pads and greatly reduces their effectiveness.

Disassembly

Refer to **Figure 129**.

1. Remove the brake pads as described in this chapter.
2. Insert a small screwdriver placed in the caliper notch (**Figure 130**) and carefully pry the retaining ring (**Figure 131**) out of the caliper body.
3. Remove the piston dust boot from the groove at the top of the piston (**Figure 132**).
4. Remove the piston from the caliper.

WARNING

Compressed air will force the piston out of the caliper under considerable force. Do not block the piston by hand because injury will occur.

5. If the piston did not come partially out of the caliper bore, perform the following:
 - a. Place a rag and a piece of wood in the caliper (**Figure 133**). Keep fingers out of the way of the piston.
 - b. Apply compressed air through the brake hose port and force the piston (**Figure 134**), out of the caliper



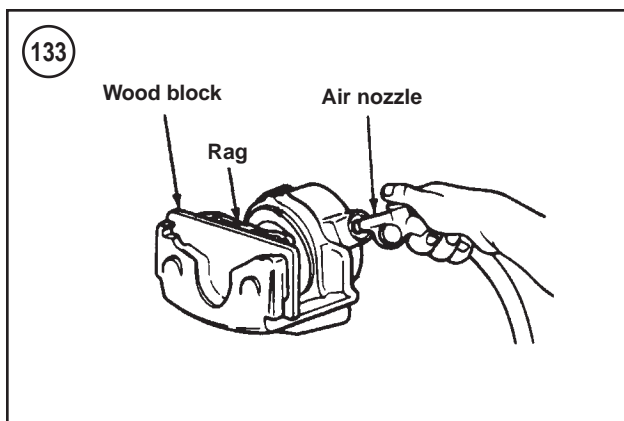
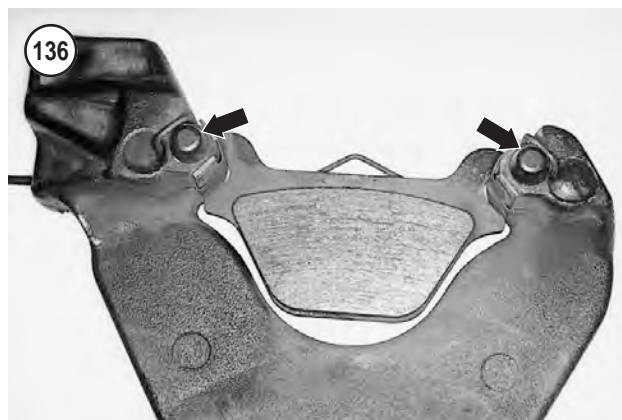

6. Remove the piston seal (A, **Figure 135**) from the groove in the caliper body and discard it.
7. Remove the rubber bushings (**Figure 136**) in the mounting bracket.

Assembly

Refer to **Figure 129**.

1. Install the new piston seal (A, **Figure 135**) into the caliper body groove.
2. Coat the piston and the caliper bore with new DOT 5 brake fluid.
3. Position the piston (**Figure 134**) with the open end facing out and install it into the caliper bore. Then push the piston in until it bottoms.
4. Install the new piston dust boot (**Figure 132**) onto the end of the piston.
5. Locate the retaining wire groove in the end of the caliper bore and install the wire into the wire groove (**Figure 131**). Make sure the retaining wire is seated completely in the groove and that it is pushing against the piston dust boot.
6. Install new rubber bushings (**Figure 136**) into the mounting bracket if worn or damaged.
7. Install the brake pads as described in this chapter.

Inspection

Service specifications for the rear caliper components are not available from the manufacturer. Replace worn, damaged or questionable parts.

1. Clean the caliper body and piston in new DOT 5 brake fluid or isopropyl alcohol and dry with compressed air.
2. Make sure the fluid passageways in the piston bores are clear. Apply compressed air to the opening to make sure they are clear. Flush the passageways, if necessary, with new brake fluid.
3. Make sure the fluid passageways (**Figure 137**) in the caliper body are clear. Apply compressed air to the opening to make sure it is clear. Flush the passageway, if necessary, with new brake fluid.
4. Inspect the piston ring retaining clip groove. Replace the caliper if the groove is damaged.

5. Inspect the banjo bolt threaded hole in the caliper body. If worn or damaged, renew with the correct size thread tap or replace the caliper.
6. Inspect the bleed valve threaded hole in the caliper body. If worn or damaged, renew with the correct thread tap or replace the caliper body.
7. Inspect the bleed valve. Apply compressed air to the opening and make sure it is clear. Flush out, if necessary, with new brake fluid. Install the bleed valve securely.
8. Inspect the piston (**Figure 138**). Clean it with new brake fluid. If it cannot be cleaned with brake fluid and a soft rag or if there are scratches on the piston surface, replace the piston.
9. Inspect the piston bore (B, **Figure 135**). Replace the caliper body if damage is found. Do not hone the caliper cylinder.
10. Check the mounting bracket for cracks or damage. Check the threads in the plate for damage. If damaged, renew the threads with the correct thread tap or replace the mounting bracket.
11. Check the pin bolt shoulder for scoring or wear; replace if necessary.
12. Check the pad retainer for cracks or damage.
13. Never reuse the piston boot or seal. Replace the piston boot and seal during assembly.

REAR BRAKE CALIPER (2000-2003 MODELS)

Review *Brake Service* in this chapter.
Refer to **Figure 139**.

Removal

NOTE

If the caliper is being removed for rear wheel service, proceed to Step 4.

1. Drain the brake fluid as described in this chapter.
2. Remove the brake line fitting (**Figure 122**). Account for any washers. Plug the end of the hose and place it in a plastic bag to prevent leaks and hose contamination.
3. Loosen the caliper body bolts. Do not remove.
4. Loosen the caliper mounting bolts.
5. Remove the brake pads as described in this chapter.
6. Remove the rear wheel as described in Chapter Thirteen.

NOTE

If the caliper is being removed for rear wheel service, insert a spacer block between the piston and the opposite side of the caliper to prevent the piston from being pushed out of the bore if the brake pedal is accidentally depressed. Suspend the caliper from the frame. Do not let the caliper hang from the brake line.



7. Slide the brake caliper off the lip of the swing arm and remove the caliper.
8. If the caliper is not going to be serviced, place it in a plastic bag to keep it clean.

Installation

1. If removed, reinstall the brake pads as described in this chapter.
2. Slide the caliper onto the swing arm so the slot on the caliper engages the lip on the swing arm.
3. Install the rear wheel as described in Chapter Thirteen.
3. Secure the brake line to the caliper with the banjo bolt. Lubricate new sealing washers with new DOT 5 brake fluid, and install a new sealing washer on each side of the hose fitting. Tighten the banjo bolt to 17-22 ft.-lb. (23-30 N•m).
5. Bleed the brake system as described in this chapter.
6. While the motorcycle is stationary with the engine off, press the brake pedal several times to seat the pads against the disc.

WARNING

Do not ride the motorcycle until the brakes operate correctly.

7. Bed the pads in gradually for the first 10 miles (160 km) by using light pressure as much as possible. Immediate hard application glazes new brake pads and greatly reduces their effectiveness.

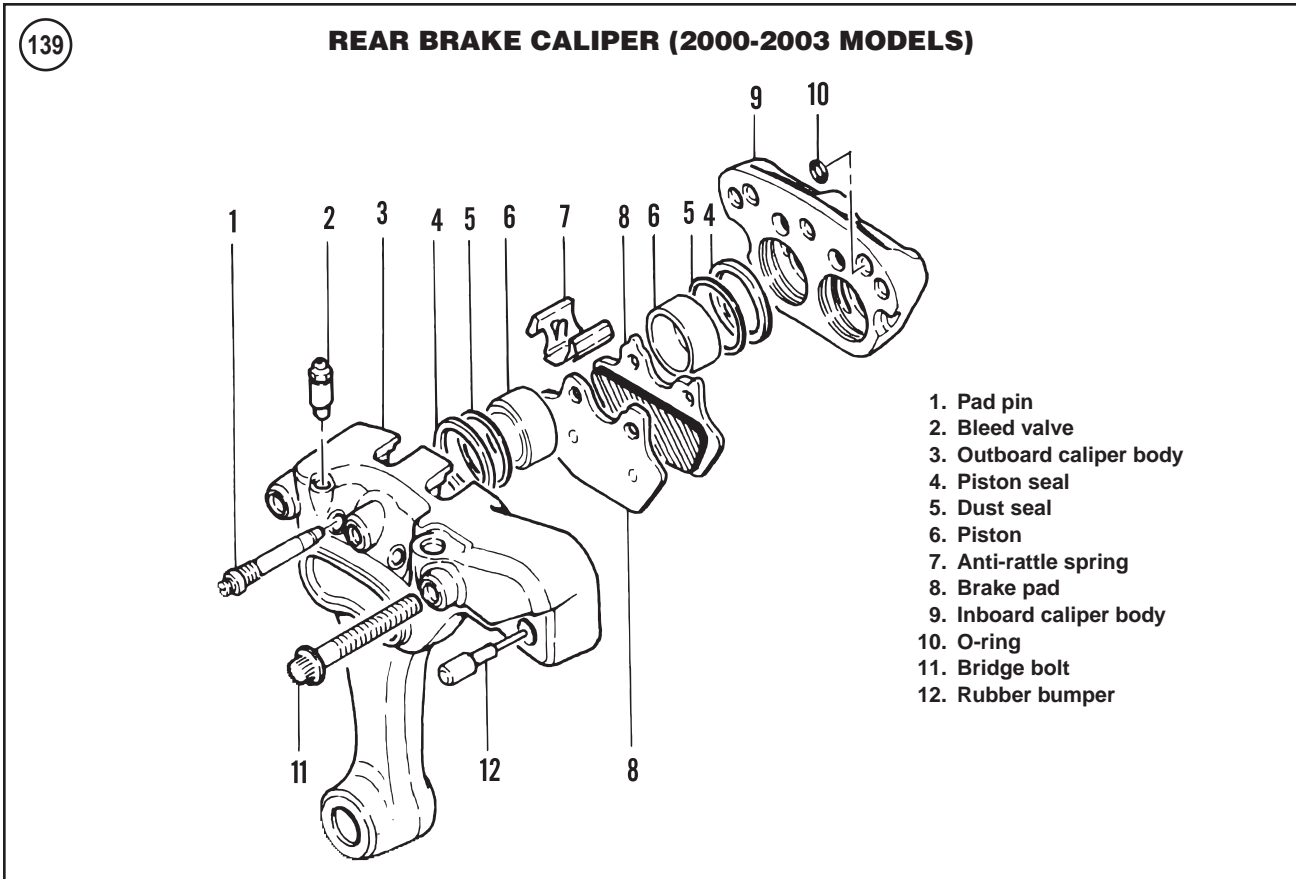

Disassembly

1. Remove the caliper as described in this section.
2. Remove the caliper body bolts (**Figure 140**) loosened during the removal procedure.
3. Separate the caliper body halves. Remove the O-rings (**Figure 141**). New O-rings must be installed every time the caliper is disassembled.

NOTE

If the pistons were partially forced out of the caliper body during removal, steps 4-6 may not be necessary. If the pistons or caliper bores are corroded or very dirty, a small amount of compressed air may be necessary to completely remove the pistons from the body bores.



4. Place a piece of soft wood and a folded shop cloth over the end of the pistons and the caliper body. Turn the assembly over and place it on the workbench with the pistons facing down.

WARNING

Compressed air forces the pistons out of the caliper body under considerable force. Do not block the piston by hand as injury will occur.

5. Apply the air pressure in short spurts to the brake fluid passageway to force out the pistons. Repeat this for the other caliper body half.

CAUTION

Do not use a sharp tool to remove the dust and piston seals from the caliper cylinders. Do not damage the cylinder surface.

6. Use a piece of wood or a plastic scraper to carefully push the dust seal and the piston seal in toward the caliper cylinder and out of their grooves. Remove the dust and piston seals.
7. If necessary, unscrew and remove the bleed valve (**Figure 142**).
8. Inspect the caliper as described in this section.

Inspection

1. Clean both caliper body halves and pistons in new DOT 5 brake fluid or isopropyl alcohol and dry them with compressed air.
2. Make sure the fluid passageways (**Figure 143**) in the piston bores are clear by applying compressed air to the openings. Flush them, if necessary, with new brake fluid.
3. Make sure the fluid passageways (**Figure 144**) in both caliper body halves are clear by applying compressed air to the openings. Flush them, if necessary, with new brake fluid.
4. Inspect the piston and dust seal grooves in both caliper bodies for damage. If they are damaged or corroded, replace the caliper assembly.
5. Inspect the banjo bolt threaded hole in the caliper body. If it is worn or damaged, clean it out with a thread tap or replace the caliper assembly.
6. Inspect the bleed valve threaded hole in the caliper body. If it is worn or damaged, clean it out with a thread tap or replace the caliper assembly.
7. Inspect the bleed valve. Apply compressed air to the opening and make sure it is clear. Flush it, if necessary, with new brake fluid. Install the bleed valve and tighten 80-100 in.-lb. (9-11 N•m).
8. Inspect both caliper bodies for damage. Check the in-board caliper mounting bolt hole threads (**Figure 145**) for wear or damage. Renew them with a thread tap or replace the caliper.
9. Inspect the cylinder walls and pistons for scratches, scoring or other damage.
10. Check the anti-rattle spring for wear or damage.

Assembly

WARNING

Never reuse old dust seals or piston seals.

1. Soak the new dust and piston seals in new DOT 5 brake fluid.
2. Coat the piston bores and pistons with new DOT 5 brake fluid.



3. Install the new piston seals into the lower grooves. Make sure the seals are properly seated in their respective grooves.
4. Install the new dust seals into the upper grooves. Make sure all seals are properly seated in their respective grooves.
5. Repeat Step 3 and Step 4 for the other caliper body half.
6. Position the pistons with the open end facing out and install the pistons into the caliper cylinders. Push the pistons in until they bottom.
7. Repeat Step 6 for the other caliper body half. Make sure all pistons are installed correctly.
8. Coat the new O-ring seals with new DOT 5 brake fluid and install the O-rings into the inboard caliper half.



9. Install the anti-rattle spring (Figure 146) onto the boss on the outboard caliper half.
10. Make sure the O-rings are still in place and assemble the caliper body halves.
11. Install the caliper body bolts (Figure 140) and tighten them securely. They will be tightened to the specified torque after the caliper is installed on the rear disc.
12. Install a new rubber caliper bumper (Figure 147) if it was removed.
13. Install the bleed valve assembly (Figure 142) if it was removed and tighten it to 80-100 in.-lb. (9-11 N•m).
14. Install the caliper as described in this section.
15. Tighten the caliper mounting bolts to 28-38 ft.-lb. (38-52 N•m).

16. Bleed the brakes as described in this chapter.

REAR MASTER CYLINDER (1986-EARLY 1987 MODELS)

Review *Brake Service* in this chapter.
Refer to **Figure 148**.

Removal/Installation

1. Open the bleed valve (Figure 149). Attach one end of a hose to the bleed valve and insert the opposite end in an empty container. Drain the brake fluid as described in this chapter.
2. Remove the bolts (Figure 150) securing the master cylinder to the sprocket cover.
3. Disconnect the brake line from the master cylinder.
4. Pull the master cylinder clear of the pushrod.
5. Remove the cupped washer (14, Figure 148), spring (15) and rubber boot (16).
6. Install by reversing the preceding removal steps while noting the following.
7. Slide the rubber boot (16, Figure 148) over the pushrod. Turn the boot so that its drain hole faces down.
8. Slide the spring (15, Figure 148) and cupped washer (14) through the pushrod and into the boot.
9. Hold the master cylinder in one hand and align the master cylinder piston with the pushrod (Figure 151). Then align the master cylinder body with the cover mounting holes and install the mounting bolts (Figure 150). Tighten the bolts to 155-190 in.-lb. (18-21 N•m).
10. Install the brake hose onto the master cylinder. Tighten the hose securely.
11. Bleed the brake system as described in this chapter.
12. Adjust the rear brake as described in Chapter Three.

Disassembly

1. Remove the master cylinder cover and diaphragm.
2. Remove the retaining ring (13, Figure 148) from the body. Then remove the following parts in order:
 - a. Piston assembly (12, Figure 148).
 - b. Piston cup (10, Figure 148).
 - c. Spring seat (9, Figure 148).
 - d. Spring (8, Figure 148).
3. Remove the seal (11, Figure 148) from the piston.

Inspection

1. Clean all parts in new DOT 5 brake fluid. Inspect the cylinder bore and piston contact surfaces for signs of wear or damage. If either part is less than perfect, replace it.
2. Check the end of the piston for wear caused by the pushrod. Replace the entire piston assembly if any portion of it is worn or damaged.

148

REAR MASTER CYLINDER (1986-EARLY 1987 MODELS)

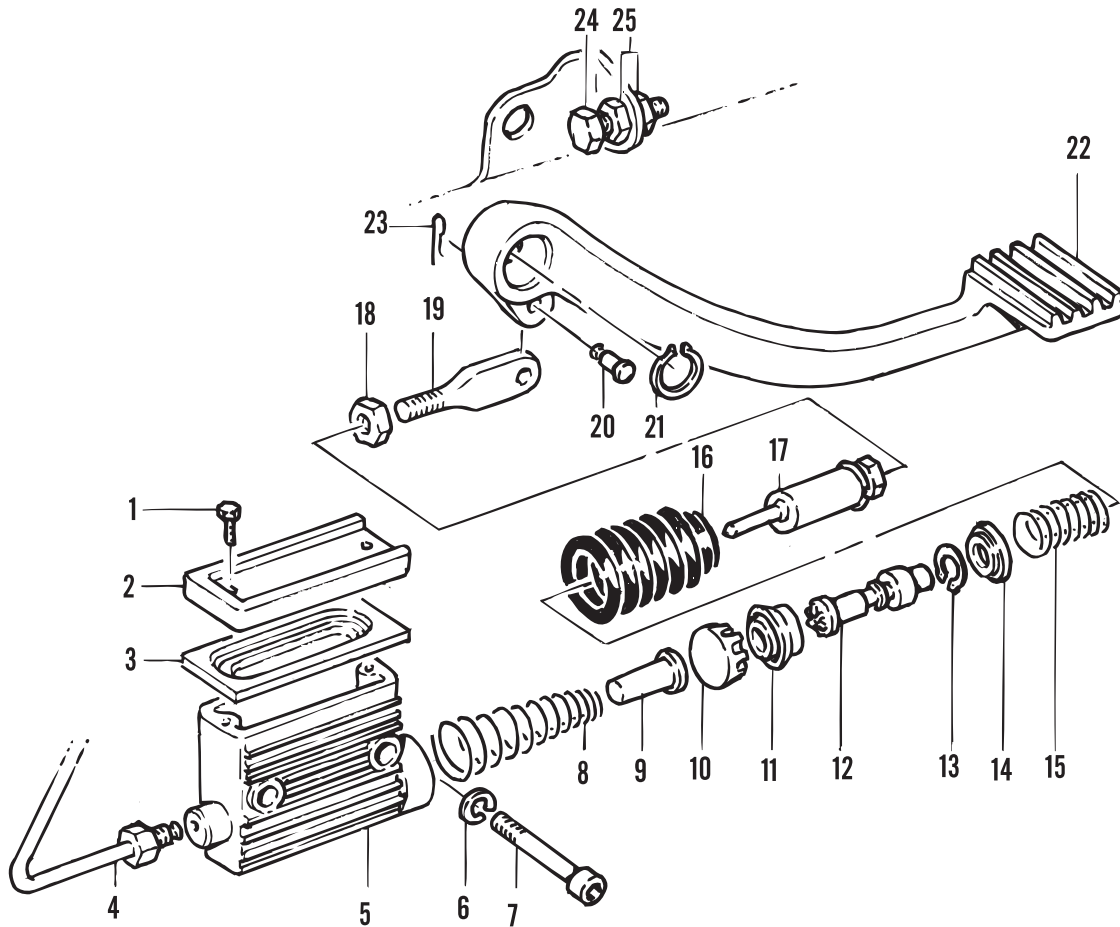

1. Screw
2. Cover
3. Diaphragm
4. Brake line
5. Housing
6. Lockwasher
7. Bolt
8. Spring
9. Spring seat
10. Piston cup
11. Seal
12. Piston
13. Snap ring
14. Cupped washer
15. Spring
16. Rubber boot
17. Pushrod
18. Nut
19. Rod end
20. Pin
21. Snap ring
22. Brake pedal
23. Cotter pin
24. Adjusting screw
25. Locknuts



4. Slide the piston cup (10, **Figure 148**) into the bore and over the spring seat (9).
5. Install the piston assembly (12, **Figure 148**) into the bore and install the retaining ring (13) into the housing groove.

REAR MASTER CYLINDER (LATE 1987-2003 MODELS)

Review *Brake Service* in this chapter.
Refer to **Figure 152**.

Removal

1. Drain the brake fluid as described in this chapter.
2. Place shop towels under the banjo bolt (**Figure 153**) and remove the fitting and the washers securing the brake hose to the master cylinder. Plug the end of the brake hose and put it in a plastic bag to prevent leaks and to keep out contamination.
3. Remove the bolts (**Figure 154**) securing the master cylinder to the sprocket cover.
4. Loosen the rod end locknut (A, **Figure 155**). Then turn the pushrod (B, **Figure 155**) until it is free of the rod end (C).
5. Remove the master cylinder.

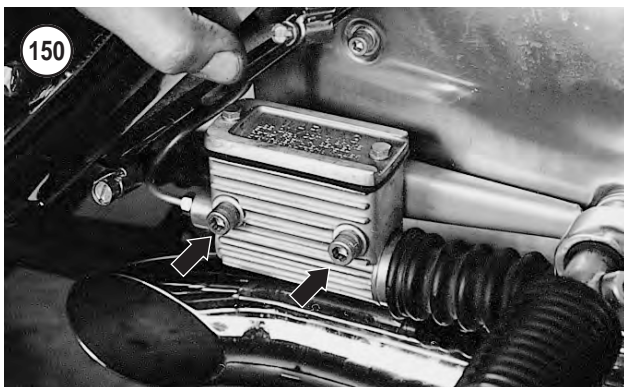

Installation

1. Slide the boot (D, **Figure 155**) over the pushrod. Turn the boot so that the drain hole faces down.
2. Position the master cylinder next to the sprocket cover. Thread the rod end (C, **Figure 155**) into the pushrod (B). Tighten the locknut (A, **Figure 155**) securely.
3. Align the master cylinder holes with the sprocket cover threaded holes and install the master cylinder mounting bolts and washers (**Figure 154**). Tighten the bolts to 155-190 in.-lb. (18-21 N•m).

NOTE

*Some models are equipped with a solid metal washer on each side of the banjo bolt. Later models are equipped with steel/rubber washers (**Figure 156**). Be sure to install new washers that match the old washers.*

3. Make sure the passages in the bottom of the master cylinder are clear. Check the reservoir cap and diaphragm for damage and deterioration. Replace if necessary.

4. Inspect the threads in the master cylinder body where the brake line screws in. If the threads are damaged, replace the master cylinder body.

Assembly

1. Soak the new cups in new DOT 5 brake fluid for at least 15 minutes to make them pliable. Coat the inside of the cylinder with new brake fluid before assembling the parts.
2. Install a new seal (11, **Figure 148**) on the piston.
3. Push the spring seat (9, **Figure 148**) into the spring (8). Then install the assembly into the cylinder bore.



4. Install a new washer (**Figure 156**) on each side of the brake hose banjo fitting. Insert the banjo bolt through the washers and banjo fitting as shown in **Figure 157**. Thread the bolt (**Figure 153**) into the cartridge locknut. Tighten the banjo nut to 17-22 ft.-lb. (23-30 N•m).
5. Bleed the rear brake as described in this chapter.
6. Adjust the rear brake as described in Chapter Three.

WARNING

Do not ride the motorcycle until the brakes operate properly.

152

REAR MASTER CYLINDER (LATE 1987-2003 MODELS)

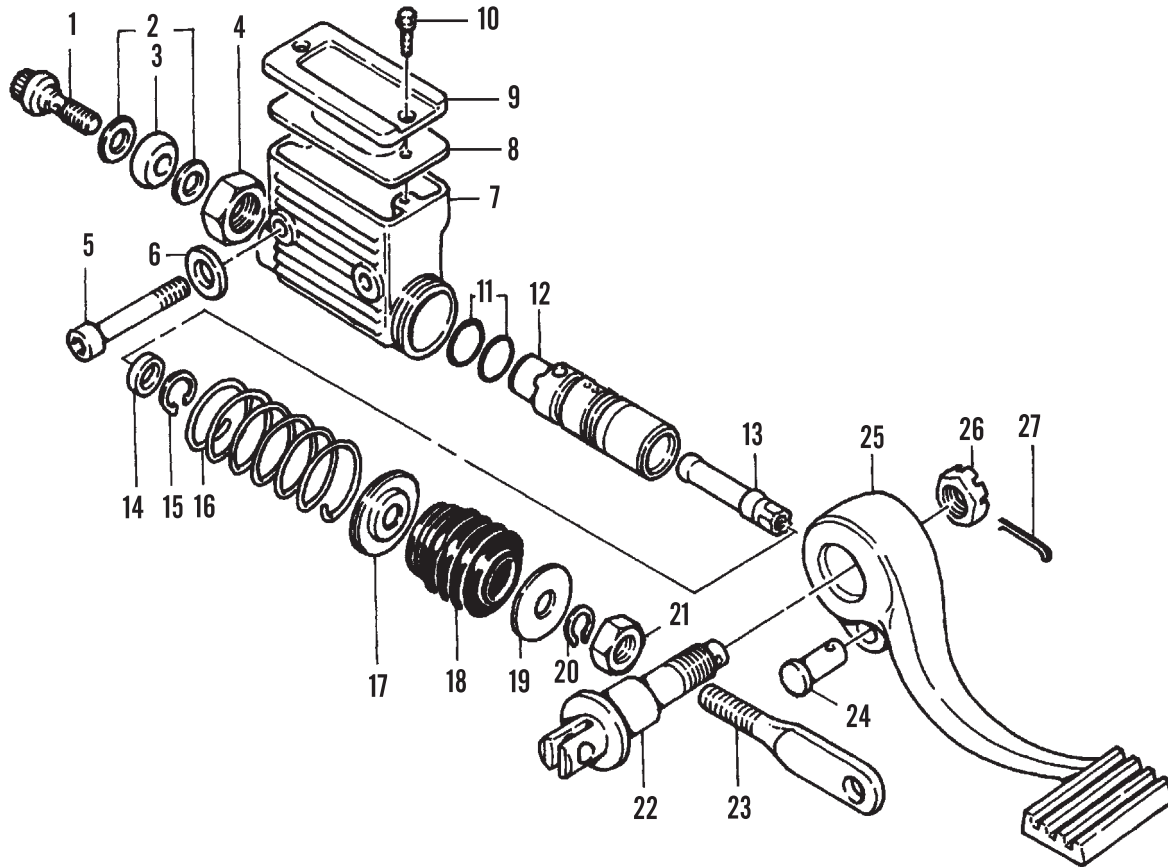

- | | |
|----------------------------|-----------------|
| 1. Banjo bolt | 15. Snap ring |
| 2. Banjo bolt washers | 16. Spring |
| 3. Brake hose | 17. Retainer |
| 4. Cartidge locknut | 18. Rubber boot |
| 5. Bolt | 19. Flat washer |
| 6. Washer | 20. Snap ring |
| 7. Master cylinder housing | 21. Nut |
| 8. Diaphragm | 22. Clevis |
| 9. Cover | 23. Rod end |
| 10. Screw | 24. Pin |
| 11. O-rings | 25. Brake pedal |
| 12. Cartidge body | 26. Nut |
| 13. Pushrod | 27. Circlip |
| 14. Spacer | |

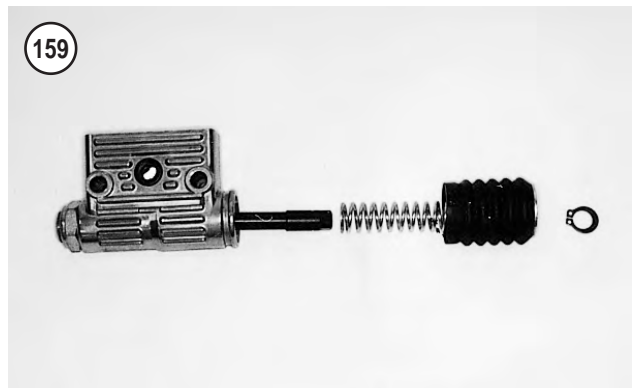
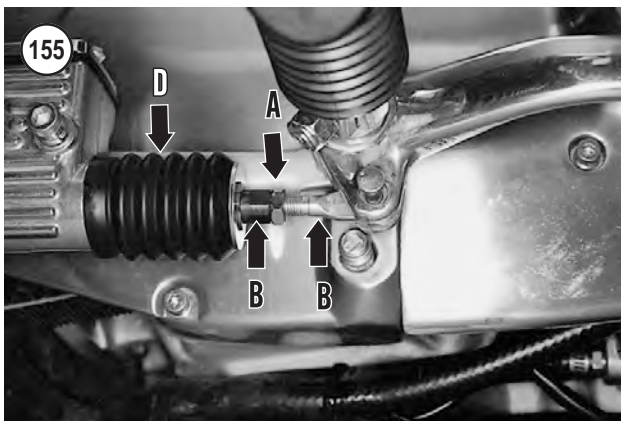
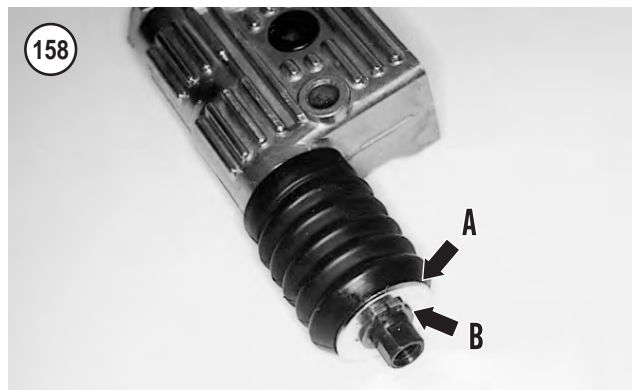
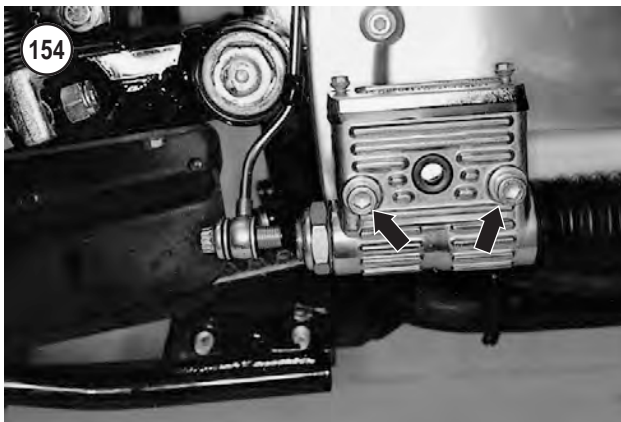

Disassembly

1. Remove the master cylinder cover and diaphragm.
2. Press down on the large washer (A, **Figure 158**) and compress the spring. Then remove the snap ring (B, **Figure 158**) from the pushrod groove. Remove the large washer, rubber boot, retainer (inside boot) and spring (**Figure 159**).

CAUTION

Do not damage the pushrod when loosening the locknut.

3. Loosen and remove the cartridge locknut (**Figure 160**).
4. Withdraw the cartridge body (**Figure 161**) and pushrod assembly from the master cylinder housing.
5. Remove the snap ring (**Figure 162**) from inside the cartridge bore.

6. Pull the pushrod (A, **Figure 163**) and spacer (B) out of the cartridge.
7. Do not remove the O-rings from the cartridge body grooves unless replacement is required. The O-rings are available only as part of the master cylinder body and master cylinder repair kits. They cannot be purchased separately.
8. Further disassembly of the cartridge body is not recommended. While the piston and spring can be removed from the cartridge body, do not remove them as the piston cups, mounted on the piston, may be damaged. If the piston or any of its components (spring and piston cups) are damaged, replace the cartridge body.

Inspection

1. Clean the master cylinder and cartridge body in new DOT 5 brake fluid. Make sure the reservoir vent hole (**Figure 164**) is clear.
2. Inspect the master cylinder bore (**Figure 165**). If the bore is cracked, corroded, scratched or damaged, replace the master cylinder assembly.
3. Check the reservoir cap and diaphragm for damage and deterioration. Replace if necessary.
4. Inspect the pushrod (A, **Figure 163**). If the pushrod is bent, cracked, corroded or damaged, replace it.
5. Inspect the cartridge body and the two O-rings (**Figure 163**). If the cartridge body threads or O-ring grooves are damaged, replace the cartridge body. Do not remove the piston assembly from the cartridge body.

Assembly

1. Wash the parts in clean DOT 5 brake fluid. Clean the cartridge body O-ring grooves with a soft brush.
2. Slide the spacer (B, **Figure 163**) onto the pushrod (A) and install the pushrod into the cartridge body with the ball end first. Then push the pushrod down to compress the piston and spring and install the snap ring (**Figure 162**) into the groove in the cartridge body. Release the pushrod and make sure the circlip is fully seated in the groove. Make sure the pushrod rotates freely after releasing it.
3. Lubricate the two new cartridge body O-rings with brake fluid and install them into the cartridge body O-ring grooves.
4. Lightly coat the cartridge body with brake fluid. Then insert the cartridge body (**Figure 161**) into the master cylinder bore with the threaded end first. Align the slot on the cartridge body with the key in the master cylinder body (**Figure 166**). Push the cartridge body through the master cylinder until it bottoms.
5. Install and tighten the cartridge body locknut (**Figure 160**) to 30-40 ft.-lb. (41-54 N•m).
6. Place the master cylinder housing in a vise with soft jaws so that the pushrod faces up.

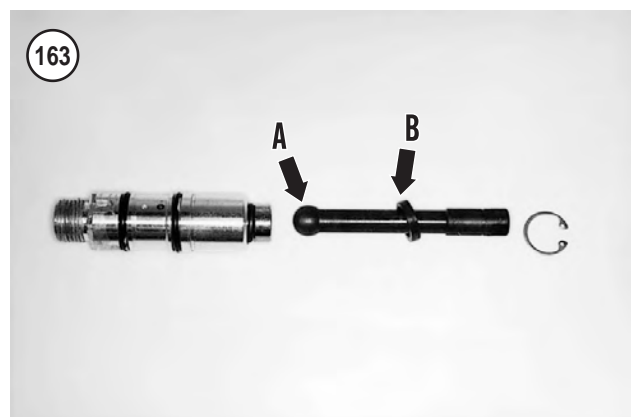
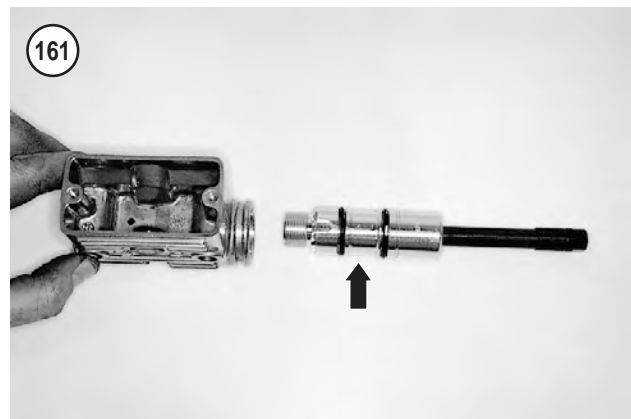



7. Install the spring and the spring retainer over the pushrod. Install the rubber boot, with the large end first, over the pushrod and slide over the spring retainer and spring. Then seat the spring retainer into the small end of the rubber boot. Turn the rubber boot so that the drain hole will be facing down when the master cylinder is installed on the motorcycle. Refer to **Figure 159**.

8. Slide the large flat washer over the pushrod and rest it against the rubber boot. Then push the washer down to compress the spring and install a new snap ring in the pushrod groove (**Figure 158**). Make sure the snap ring seats in the groove completely. Release the spring and allow the large washer to seat against the snap ring.

9. Install the master cylinder as described in this section.

WARNING

Do not ride the motorcycle until the brakes operate properly.

BRAKE HOSE AND LINE REPLACEMENT

Review *Brake Service* in this chapter.

A combination of steel and flexible brake lines are used to connect the master cylinder to the brake caliper. Banjo bolts are used to connect brake hoses to the master cylinder or brake calipers. A threaded fitting connects the brake line to the rear master cylinder and rear brake caliper on 1986-early 1987 models. Steel/rubber banjo washers (**Figure 167**) are used to seal the hose fittings, except on early models which may use all-metal washers. Be sure to install new banjo bolt washers that match the old washers, otherwise, leaks may occur.

While there is no factory-recommended replacement interval for the brake hoses, it is a good idea to replace a hose when the flexible portion shows signs of swelling, cracking or other damage. Likewise, the brake hose should be replaced when the metal portion leaks or if there are dents or cracks.

Front Brake Hose Removal/Installation

A combination steel/flexible brake hose (**Figure 168**) is used to connect the front master cylinder to the front brake caliper.

When purchasing a new hose, compare it to the old hose to make sure that the length and angle of the steel hose portion is correct. Install new banjo bolt washers that match the old washers.

1. Drain the brake fluid from the front brake system as described in this chapter.

2. Before removing the brake line, note how the brake line is routed from the master cylinder to the caliper. In addition, note the number and position of the metal hose clamps and plastic ties used to hold the brake line in place. Install the

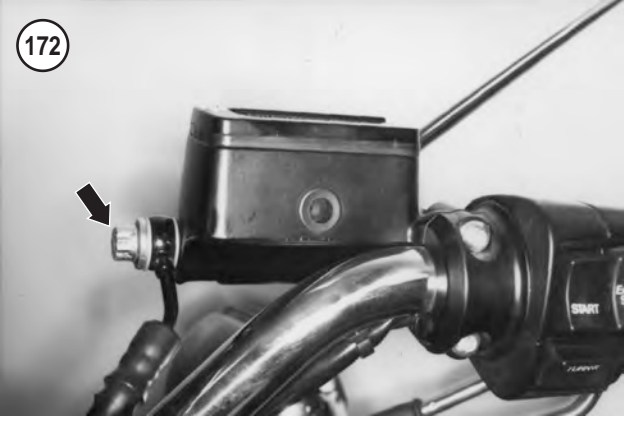
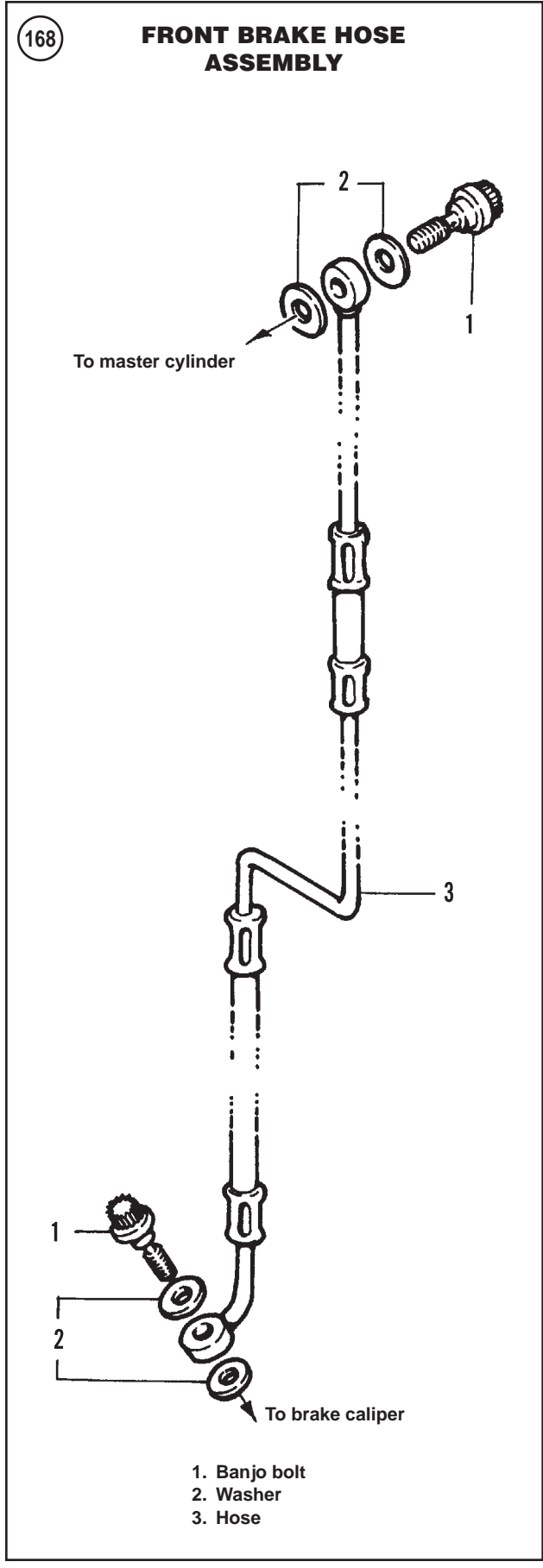

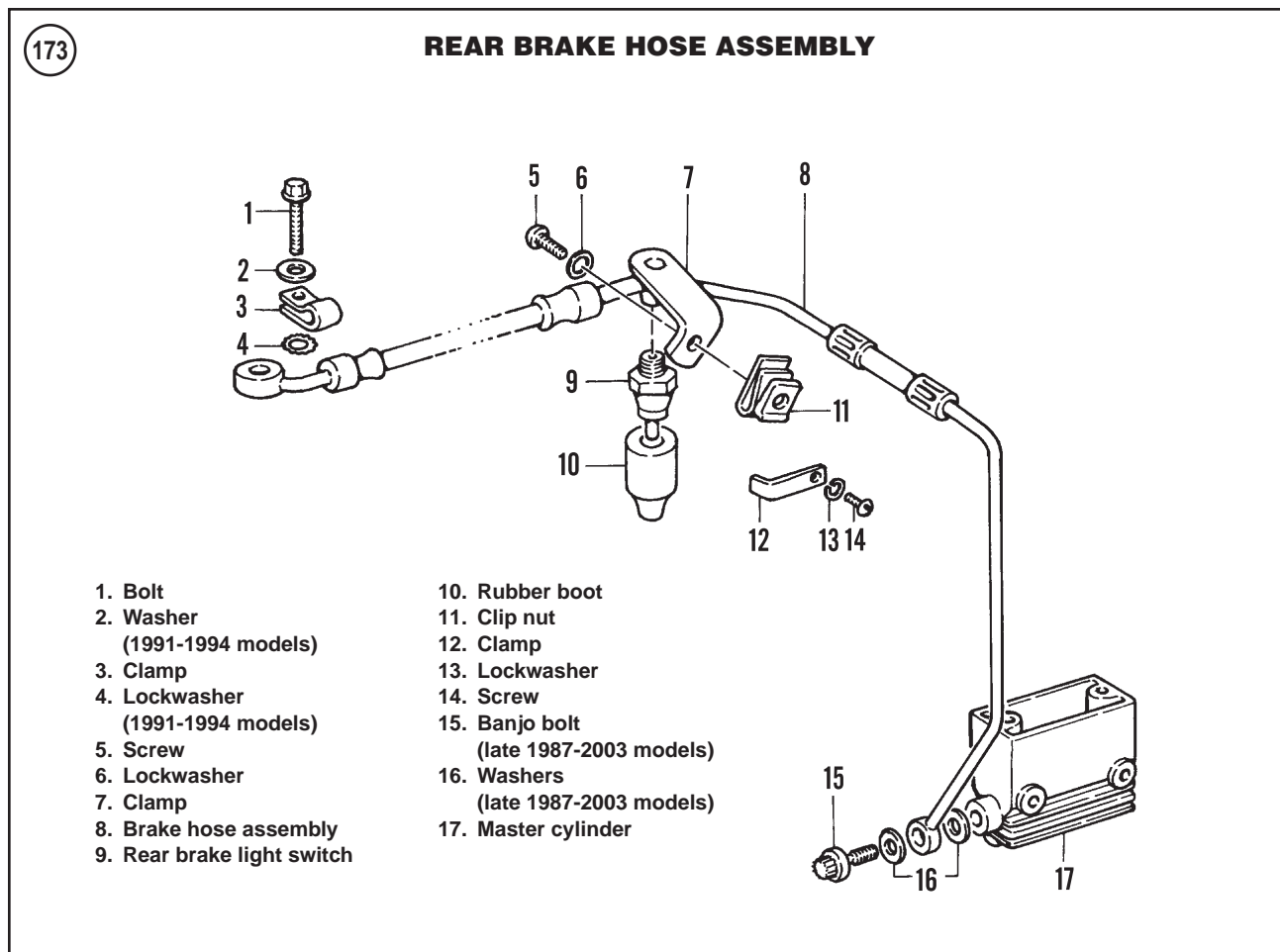

brake hose following the same path and secured at the same position.

3. Cut the plastic ties and discard them. New plastic ties must be installed.

4. Remove the screw or nut holding the metal clamps around the brake line. Spread the clamp and remove it from the brake line. See **Figure 169** and **Figure 170**, typical. The metal clamps can be reused.

CAUTION

After disconnecting the brake hose, plug the open ends and put them in plastic bags to prevent spills and to keep out contamination.

5. Remove the banjo bolt and washers securing the hose at the brake caliper (**Figure 171**).

6. Remove the banjo bolt and washers securing the hose at the master cylinder (**Figure 172**).

7. Remove the brake hose from the motorcycle.

8. If reusing the brake hose assembly, inspect it as follows:

- a. Check the metal pipe portion for cracks or fractures. Check the junction where the metal pipe enters and exits the flexible hose. Check the crimped clamp for looseness or damage.

b. Check the flexible hose portion for swelling, cracks or other damage.

c. Replace the hose assembly, if necessary.

9. Install the brake hose, banjo bolt washers and the banjo bolt in the reverse order of removal. Install the banjo bolt washers on both sides of the banjo hose fitting; see **Figure 168**. The hose must not be twisted or kinked.

10. Install the clips and guides to hold the brake hose in place.

11. Tighten the banjo bolts to 17-22 ft.-lb. (23-30 N•m).

12. Refill the master cylinder with new DOT 5 brake fluid as described in Chapter Three.

13. Bleed the brake system as described in this chapter.

WARNING

Do not ride the motorcycle until the brakes operate properly.

Rear Brake Hose Removal/Installation

A single combination steel/flexible brake hose (**Figure 173**) is used to connect the rear master cylinder to the rear brake caliper.

When purchasing a new hose, compare it to the old hose to make sure that the length and angle of the steel hose portion is correct. Install banjo bolt washers (**Figure 167**) that match the old washers.

1. Drain the hydraulic brake fluid from the rear brake system as described in this chapter.
2. Before removing the brake line, note how the brake line (**Figure 174**, typical) is routed from the master cylinder to the caliper. In addition, note the number and position of the metal hose clamps and plastic ties used to hold the brake line in place. Install the brake hose following the same path and secured at the same position.
3. Cut the plastic ties and discard them. New plastic ties must be installed.
4. Remove the screw or nut holding the metal clamps around the brake line. Spread the clamp and remove it from the brake line. The metal clamps can be reused.

CAUTION

After disconnecting the brake hose plug the open ends and put them in plastic bags to prevent leaks and to keep out dirt.

5. Remove the banjo bolt and washers securing the hose at the brake caliper (**Figure 175**).
6. Remove the banjo bolt and washers securing the hose at the master cylinder (**Figure 176**).
7. Disconnect the rear brake light switch electrical connectors at the switch (**Figure 177**).
8. Remove the brake hose from the motorcycle.
9. If reusing the brake hose assembly, inspect it as follows:
 - a. Check the metal pipe portion for cracks or fractures. Check the junction where the metal pipe enters and exits the flexible hose. Check the crimped clamp for looseness or damage.
 - b. Check the flexible hose portion for swelling, cracks or other damage.
 - c. Replace the hose assembly, if necessary.
10. If necessary, remove the rear brake light switch from the tee fitting in the rear brake line (**Figure 173**). Reverse to install the switch. Tighten the rear brake light switch to 84-120 in.-lb. (9-14 N•m).
11. Install a new brake hose, banjo bolt washers in the reverse order of removal. Be sure to install new sealing washers on both sides of the hose fitting. See **Figure 176** and **Figure 178**.
12. Refill the master cylinder with new DOT 5 brake fluid.
13. Bleed the rear brake system as described in this chapter.

WARNING

Do not ride the motorcycle until the brakes operate properly.

BRAKE DISC

Review *Brake Service* in this chapter.

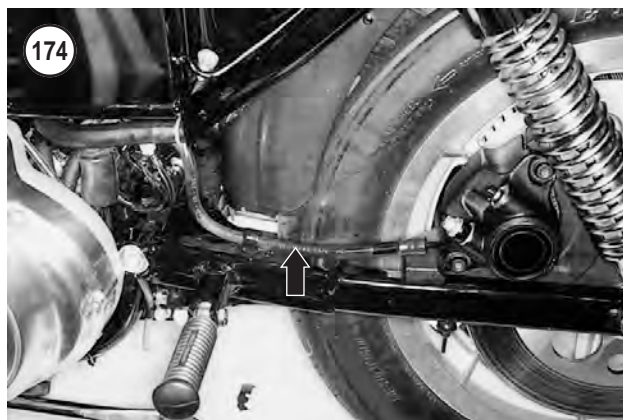



A single brake disc is bolted to the front and rear wheels except on 1200S, which is equipped with two brake discs mounted on the front wheel. Brake discs should be checked for runout and thickness. The minimum disc thickness is stamped on original equipment brake discs (**Figure 179**). **Table 1** lists disc brake specifications.

Removal/Installation

CAUTION

Do not set the wheel down on the brake disc surface, as it may be damaged.

1. Remove the front or rear wheel as described in Chapter Thirteen.

NOTE

Place a spacer between the brake pads in place of the disc. If the brake lever is inadvertently applied, the pistons will not be forced out of the caliper. If the pistons are forced out, disassemble the caliper and reseat the pistons as described in this chapter.



2. Remove the bolts and locknuts securing the brake disc to the hub and remove the disc. See **Figure 180**, typical.
3. Check the brake disc bolts and locknuts for thread damage. Replace worn or damaged fasteners.
4. Clean the disc and the disc mounting surface with brake cleaner or contact cleaner. Allow surfaces to dry before installation.

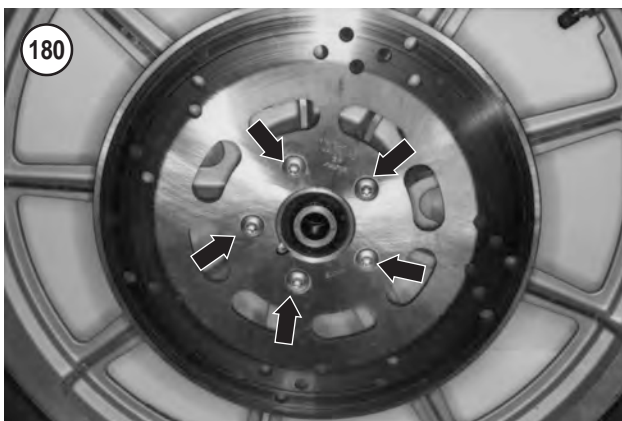

5. To install the front brake disc perform the following:
 - a. On 1986-1994 models, align the notch in the disc with the 1/4 in. (6.3 mm) diameter hole in the hub and install the disc; see A, **Figure 181**.
 - b. Install new T-40 Torx bolts (B, **Figure 181**). Tighten to the bolts to 16-24 ft.-lb. (22-33 N•m).

- 6A. To install the rear brake disc on 1986-1991 models perform the following:
 - a. On cast wheels, install new bolts and tighten them to 23-27 ft.-lb. (31-37 N•m).
 - b. On laced wheels, install new bolts and locknuts and tighten them to 23-27 N•m (31-37 ft.-lb.).

- 6B. To install the rear brake disc on 1992-2003 models perform the following:
 - a. The Torx bolts (**Figure 182**) used to secure the rear brake disc were originally equipped with a patch of thread locking compound. The manufacturer specifies that these bolts can be used for three removal and installation cycles. After the third cycle, discard the bolts and install a new set.
 - b. On cast wheels, install bolts and tighten to 30-45 ft.-lb. (41-61 N•m).
 - c. On laced wheels, install the bolts and locknuts. Tighten to 30-45 ft.-lb. (41-61 N•m).

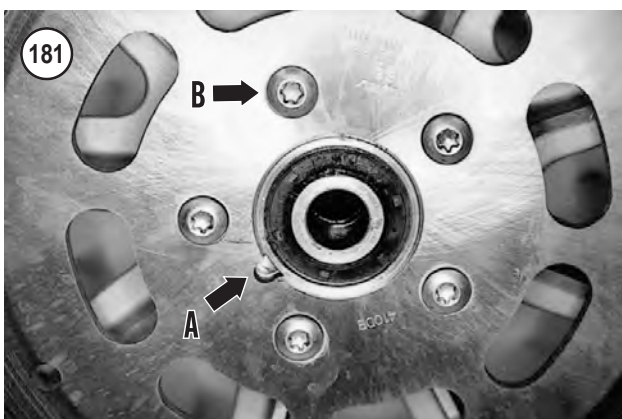

Inspection

It is not necessary to remove the disc from the wheel to inspect it. Small marks on the disc are not important, but radial scratches deep enough to snag a fingernail reduce braking effectiveness and increase brake pad wear. If these grooves are found, the disc should be resurfaced or replaced.

1. Measure the thickness around the disc at several locations (**Figure 183**). The disc must be replaced if the thickness at any point is less than the minimum thickness stamped on the disc (**Figure 179**). Refer to **Table 1** for thickness specifications.

2. Clean any rust or corrosion off the disc and wipe clean with brake cleaner or lacquer thinner. Never use an oil-based solvent that may leave an oil residue on the disc.



BLEEDING

WARNING

Do not ride the motorcycle until the brakes are operating correctly.

WARNING

Dispose of the brake fluid expelled during the bleeding process. Do not reuse brake fluid.

NOTE

These procedures are shown on the front wheel and apply to the rear wheel as well.

NOTE

Some calipers are equipped with two bleed screws. Perform the bleeding procedure for both bleed screws.

NOTE

Before bleeding the brake, make sure all brake hoses and lines are tight.

NOTE

If bleeding is difficult, allow the fluid to stabilize for a few hours. Repeat the bleeding procedure when the tiny bubbles in the system settle out.

NOTE

Do not allow the master cylinder reservoir to empty during the bleeding operation or more air will enter the system. If this occurs, repeat the procedure.

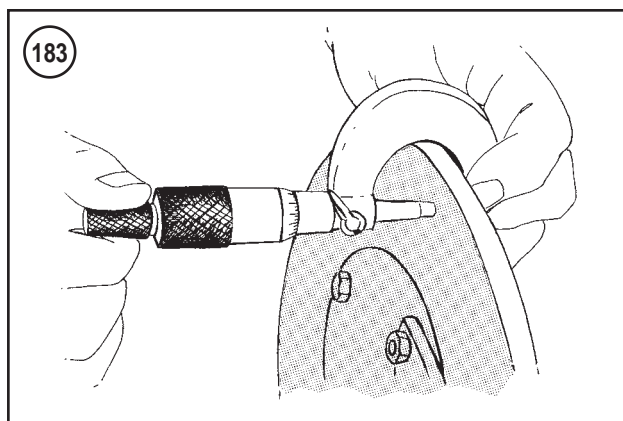

General Bleeding Tips

When bleeding the brakes, not the following:

1. Review *Brake Service* in this chapter.
2. Clean the bleed valves and the area around the valves of debris. Make sure the passageways in the end of the bleed valves are clear and open.

3. Use a box-end wrench to open and close the bleed valves. This helps prevent damages to the valves.
4. Replace damaged bleed valves.
5. Install the box-end wrench on the bleed valve before installing the catch hose. This allows the wrench to remain in place during the procedure.
6. Use a clear plastic hose to allow visual inspection of the brake fluid as it leaves the caliper. Air bubbles visible in the catch hose indicate air in the brake system.
7. Depending on the play of the bleed valve when it is loosened, it may be possible to see air in the catch hose even though no air is in the system. A loose or damaged catch hose can also cause air leaks. In both cases, air is being introduced into the hose at the bleed valve threads and the catch hose connection, and not from within the brake system.
8. Open the bleed valve just enough to allow fluid to pass through the valve and into the catch bottle. The farther the bleed valve is opened, the looser the valve becomes. This allows air to be drawn into the system from around the valve threads.
9. If air is suspected of entering from around the bleed valve threads, pack the area around the valve with silicone brake grease.

WARNING

Do not force grease into the caliper past the bleed valve threads. This can block the bleed



valve passageways and contaminate the brake fluid.

10. If the system is difficult to bleed, lightly tap the banjo bolt on the master cylinder a few times. It is not uncommon for air bubbles to become trapped in this hose connection where the brake fluid exits the master cylinder. When a number of bubbles appear in the master cylinder reservoir after tapping the banjo bolt, it means air is trapped in this area.

11. When the front master cylinder cover is removed and brake fluid is in the reservoir, brake fluid can spurt out of the reservoir any time the lever is operated. To prevent this, make sure to leave the reservoir cover in place except when filling it with fluid.

12. When adding brake fluid to the reservoir, do not allow fluid to enter the cover bolt holes. This fluid leaks out when the cover bolts are installed and tightened. Before installing the cover, inspect the holes for fluid and remove any residual fluid.

Vacuum Bleeding

This one-person procedure uses a hydraulic brake bleed-
ing tool (Figure 184, typical).

1. Support the motorcycle on a suitable stand.
2. Remove the cap (Figure 185) from the caliper bleed valve.

3. Place a clean shop cloth over the caliper to protect it from accidental brake fluid spills.

4. Assemble the bleeding tool according to the manufacturer's instructions. Connect it to the caliper bleed valve (Figure 185).

5. Clean the top of the master cylinder reservoir.

6. Refer to Chapter Three and verify that the master cylinder reservoir is full.

7. Operate the pump several times to create a vacuum in the line. Open the bleed valve. Brake fluid will quickly draw from the caliper into the bleed tool reservoir. Tighten the caliper bleed valve before the fluid stops flowing through the hose. To prevent air from being drawn into the system through the master cylinder, add fluid to maintain its level at the top of the reservoir.

8. Continue the bleeding process until the fluid drawn from the caliper is bubble free. If bubbles are withdrawn with the brake fluid, more air is trapped in the line. Repeat Step 7 while being sure to refill the master cylinder to prevent air from being drawn into the system.

9. When the brake fluid is free of bubbles, tighten the bleed valve and remove the brake bleeder tool. Reinstall the bleed valve cap.

10. If necessary, add fluid to correct the level in the master cylinder reservoir as described in Chapter Three.

11. On 1200S models, repeat Steps 1-10 for the other front brake caliper.

12. Reinstall the reservoir diaphragm, diaphragm plate and cover.

13. Test the feel of the brake lever or pedal. It must be firm and offer the same resistance each time it is operated. If it feels spongy, air is still in the system and it must be bled again. After bleeding the system, check for leaks and tighten all fittings and connections as necessary.

14. Test ride the motorcycle slowly at first to make sure that the brakes are operating properly.

Manual Bleeding

1. Support the motorcycle on a suitable stand.

2. Remove the dust cap (Figure 185) from the caliper bleed valve.

3. Place a clean shop cloth over the caliper to protect it from accidental brake fluid spills.

4. Clean the top of the master cylinder reservoir of all dirt and foreign matter.

5. Refer to Chapter Three and verify that the master cylinder reservoir is full.

6. Connect a length of clear tubing to the bleed valve on the caliper (Figure 185). Place the other end of the tube into a clean container (Figure 186). Fill the container with enough new DOT 5 brake fluid to keep the end of the tube submerged. The tube must be long enough so that a loop can be made higher than the bleed valve to prevent air from being drawn into the caliper during bleeding.

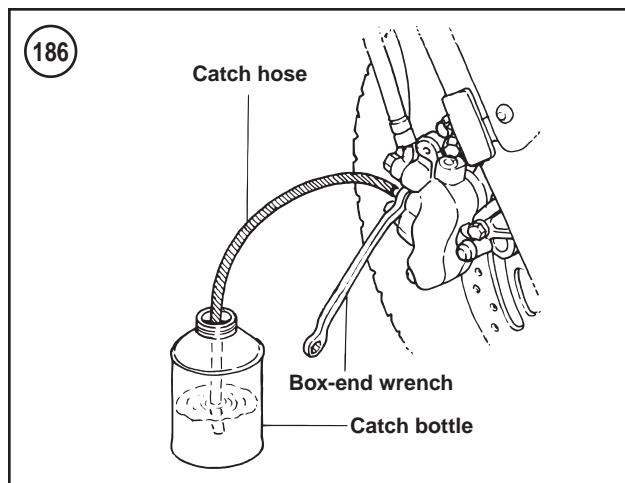

7. Slowly apply the brake lever or brake pedal several times. Hold the lever in the applied position and open the bleed valve about 1/2 turn. Allow the lever to travel to its limit. When the limit is reached, tighten the bleed valve, then release the brake lever. As the brake fluid enters the system, the level will drop in the master cylinder reservoir. Maintain the full fluid level in the reservoir to prevent air from being drawn into the system.

8. Continue the bleeding process until the fluid coming from the hose is completely free of air bubbles. If the fluid is being replaced, continue until the fluid emerging from the hose is clean.

9. Hold the lever in the applied position and tighten the bleed valve. Remove the bleed tube and install the bleed valve dust cap.

10. If necessary, adjust the fluid level in the master cylinder reservoir as described in Chapter Three.

11. On 1200S models, repeat Steps 1-10 for the other caliper.

12. Install the diaphragm, diaphragm plate and cover.

13. Test the feel of the brake lever or pedal. It must be firm and offer the same resistance each time it is operated. If it feels spongy, it is likely that there is still air in the system and it must bleed it again. After bleeding the system check for leaks and tighten all fittings and connections as necessary.

14. Test ride the motorcycle slowly at first to make sure that the brakes are operating properly.

BRAKE FLUID DRAINING

Before disconnecting a brake hose from the front or rear brake, drain the brake fluid as described in this section. Doing so reduces the amount of brake fluid that can spill out when disconnecting the brake hoses and lines from the system.

Review *Brake Service* in this chapter. Review *Brake Bleeding* in this chapter.



Front Brake Lever Line

1. Support the motorcycle on a suitable stand.
2. Turn the handlebars to level the front master cylinder and remove the reservoir cover (**Figure 187**), diaphragm plate and diaphragm.
 - 3A. Attach a vacuum bleeding tool as described in *Bleeding the System* in this chapter.
 - 3B. Attach a tube to the bleed valve and submerge the tube into a container as described in *Bleeding the System* in this chapter.
 - 4A. Open the bleed valve and operate the vacuum bleeder tool to draw out as much of the fluid as possible from the brake line.
 - 4B. Open the bleed valve and apply the brake lever to pump to force brake fluid from the line.

5. Close the bleed valve and disconnect the vacuum tool or the hose.
6. On 1200S models, repeat for the other caliper.
7. Service the brake components as described in this chapter.

Rear Brake Pedal Line

1. Support the motorcycle on a suitable stand.
2. Remove the rear brake master cylinder reservoir cap (**Figure 188**) from the reservoir.
- 3A. Attach a vacuum bleeding tool as described in *Bleeding the System* in this chapter.
- 3B. Attach a tube to the bleed valve and submerge the tube into a container as described in *Bleeding the System* in this chapter.
- 4A. Open the bleed valve and operate the vacuum bleeder tool to draw out as much of the fluid as possible from the brake line.

- 4B. Open the bleed valve and apply the brake lever to pump to force brake fluid from the line.
4. Disconnect the brake bleeder and remove it from the brake caliper.
5. Service the brake components as described in this chapter.

FLUSHING THE BRAKE SYSTEM

WARNING

Never reuse old brake fluid. Properly discard all brake fluid flushed from the system.

When flushing the brake system, use DOT 5 brake fluid as a flushing fluid. Flushing consists of pulling new brake fluid through the system until the new fluid appears at the caliper and without the presence of any air bubbles. To flush the brake system, follow one of the bleeding procedures described in the *Bleeding the System* section in this chapter.

Table 1 BRAKE SYSTEM SPECIFICATIONS

| | |
|--|---------------------|
| Brake fluid | DOT 5 |
| Brake pad thickness (min.) | 0.062 in. (1.6 mm) |
| Brake disc runout (max.) | 0.008 in. (0.2 mm) |
| Rear master cylinder pushrod free play | 0.04 in. (1.02 mm) |
| Brake disc thickness (min.) | |
| Front | 0.180 in. (4.57 mm) |
| Rear | 0.205 in. (5.21 mm) |

Table 2 BRAKE SYSTEM TORQUE SPECIFICATIONS

| | ft.-lb. | in.-lb. | N•m |
|--|---------|---------|-------|
| Banjo bolt | 17-22 | – | 23-30 |
| Bleed valve | – | 80-100 | 9-11 |
| Brake pad pin, front and rear (2000-2003 models) | – | 180-204 | 20-23 |
| Brake pad retainer screw (1986-1999 models) | – | 40-50 | 5-6 |
| Front caliper lower mounting pin (1986-1999 models) | 25-30 | – | 34-41 |
| Front caliper mounting bolts (2000-2003 models) | 28-38 | – | 38-52 |
| Front caliper upper mounting screw (1986-1999 models) | 25-30 | – | 34-41 |
| Master cylinder clamp screws | – | 70-80 | 8-9 |
| Master cylinder cover screws | – | 6-8 | 0.5-1 |
| Rear brake light switch | – | 84-120 | 9-14 |
| Rear caliper mounting bolts (late 1987-1999 models) | 15-20 | – | 20-27 |
| Rear caliper mounting bolts (2000-2003 models) | 28-38 | – | 38-52 |
| Rear caliper mounting screws (1986-early 1987 models) | – | 132-168 | 15-19 |
| Rear master cylinder cartridge body locknut (late 1987-2003 models) | 30-40 | – | 41-54 |
| Rear master cylinder mounting bolts | – | 155-190 | 18-21 |
| Brake disc mounting bolts | | | |
| Front | 16-24 | – | 22-23 |
| Rear | | | |
| 1986-1991 models | 23-27 | – | 31-37 |
| 1992-2003 models | 30-45 | – | 41-61 |

CHAPTER SEVENTEEN

BODY

This chapter covers body components including the seat, fenders, footrests, forward controls, sidestand and fork lock.

Fuel tank removal is covered in Chapter Ten or Chapter Eleven.

Table 1 is at the end of this chapter.

SEAT

Removal/Installation

1. Remove the seat retaining bolt (**Figure 1**).
2. Move the seat towards the rear of the motorcycle so the seat disengages from the frame tab.

NOTE

On 1997-2003 models, account for the nylon retaining clip that retains the seat bolt nut in the fender.

3. Reverse the removal steps to install the seat. Be sure the seat is secure before operating the motorcycle.

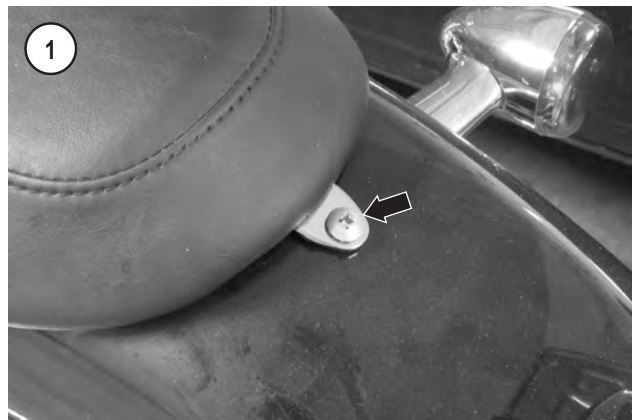

FRONT FENDER

Removal/Installation

Refer to **Figure 2**.

1. Hold the front fender so it cannot fall after removal of the mounting bolts.
2. Remove the locknuts and bolts on both sides of the fender.
3. Remove the front fender.

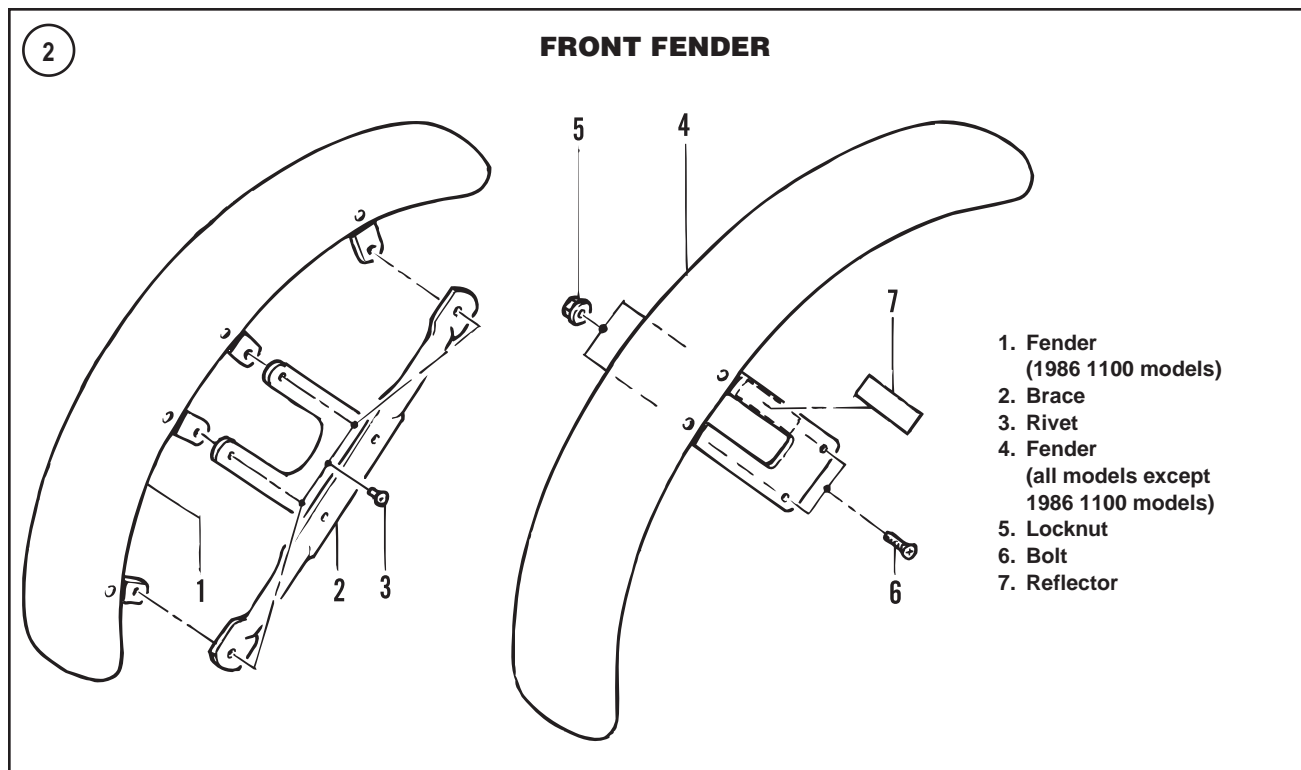

4. Reverse the removal steps to install the front fender. Tighten the locknuts to 96-156 in.-lb. (11-18 N•m).

REAR FENDER

Removal/Installation

1986-1993 models

Refer to **Figure 3**.

1. Remove the seat as described in this chapter.
2. Disconnect the negative battery cable (Chapter Twelve).
3. Locate the turn signal and taillight/brake light terminal block in the area beneath the seat. Disconnect the terminal block connectors. Remove the connector on the wire lead to the rear fender as described in Chapter Twelve.
4. Remove the circuit breakers (A, **Figure 4**) from the retaining clips on the rear fender.
- 5A. On 1986-1989 models, remove the turn signal mounting bolts inside the fender and remove turn signals.
- 5B. On 1990-1993 models, remove the turn signal retaining nuts inside the fender and remove turn signals.
6. Note the location of spacers when removing fender retaining fasteners. Remove the mounting bolt, spacer and locknut that attaches the front of the fender to the frame bracket (B, **Figure 4**).
7. Remove bolts on both sides of the fender (**Figure 5**, typical) and remove the fender.
8. Reverse the removal steps to install the rear fender while noting the following:

- a. Install the short fender mounting bolts in the rear fender mounting holes.
- b. Install the fender mounting bolt (B, **Figure 4**) so the nut is on top. Tighten the nut to 120 in.-lb. (13.6 N•m).
- c. On 1986-1989 models, tighten the turn signal mounting bolt to 33 ft.-lb. (45 N•m).
- d. On 1990-1993 models, tighten the turn signal retaining nut to 96-156 in.-lb. (11-17 N•m).

1994-2003 models

Refer to **Figure 6**, typical.

1. Remove the seat as described in this chapter.
2. Note the location of spacers when removing fender retaining fasteners. Remove the mounting bolt, spacer and locknut that attaches the front of the fender to the frame bracket (**Figure 7**).
3. On both sides, remove the rear turn signal retaining nut and spacer on the inside of the rear fender.
4. On both sides, remove the strut cover retaining screws, nuts and spacers (**Figure 5**). Move the strut covers out of the way.
5. On 1994-1998 models, locate the turn signal and taillight/brake light connectors in the area beneath the seat. Disconnect the connectors. Remove the connector on the taillight/brake light wire lead to the rear fender as described in Chapter Twelve.
6. On 1999-2003 models, depress the locking tab on the top of the connectors and remove the left- and right-turn

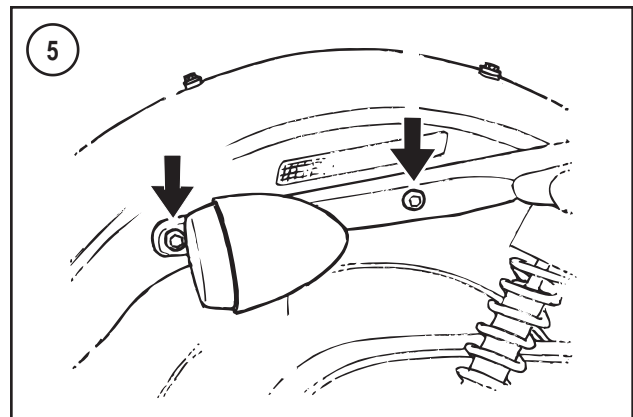
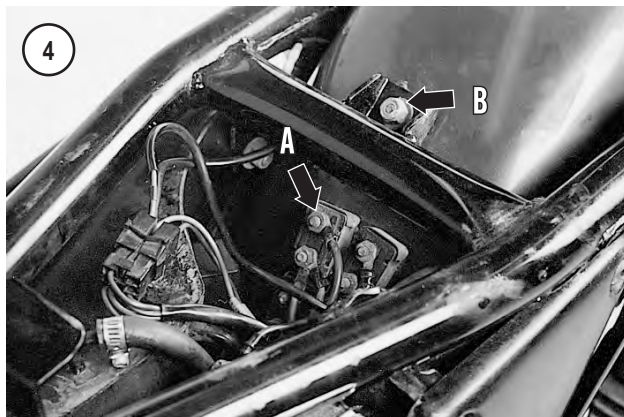
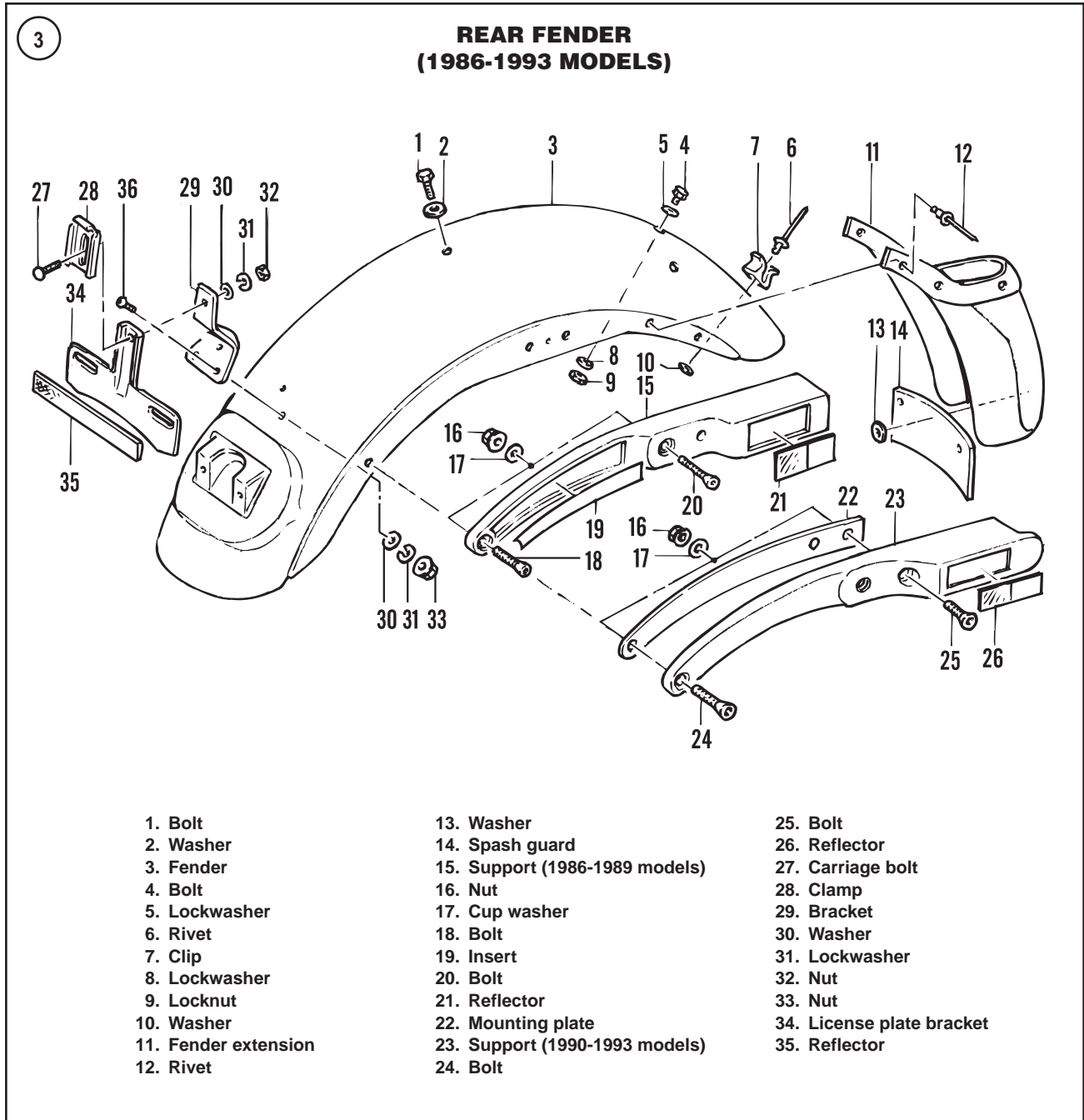

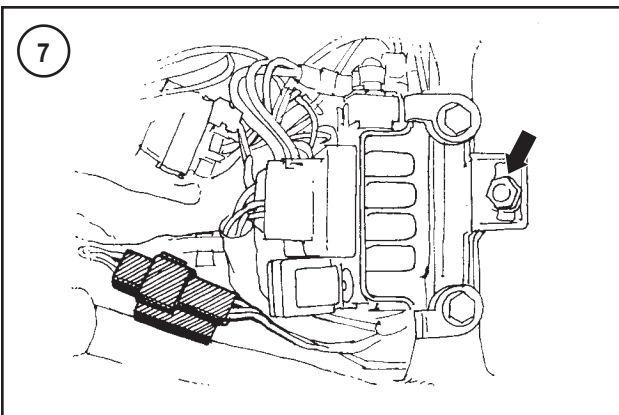
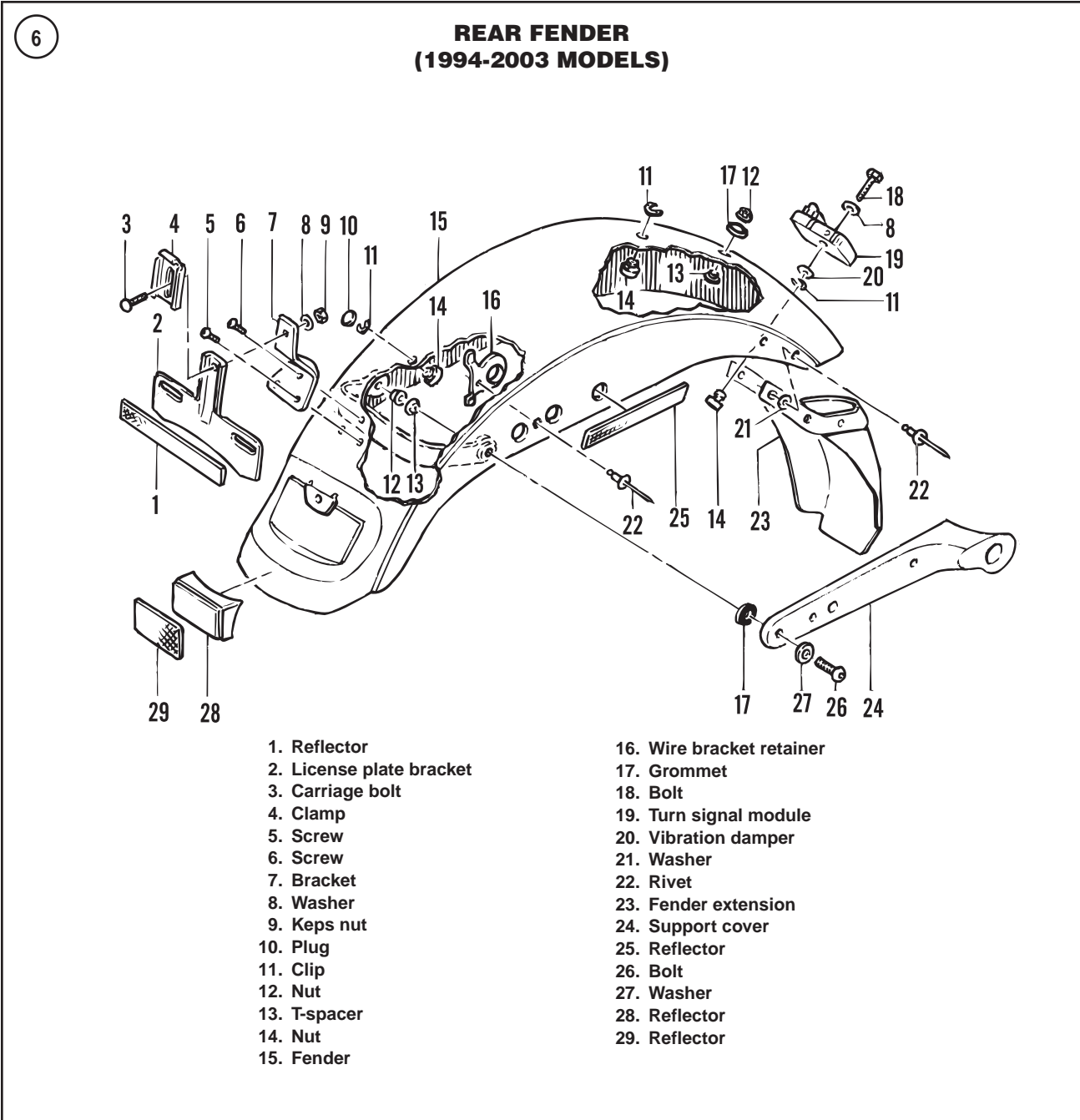

signal connectors and the power connector from the circuit board in the taillight base (**Figure 8**).

7. On 1998-2003 models, disconnect the turn signal module connector. See Chapter Twelve.

8. Remove the rear fender, including the taillight base and turn signal module.

9. If necessary, remove the taillight base and turn signal module (1998-2003 models) from the rear fender.

10. Reverse the removal steps to install the rear fender while noting the following:

- a. Tighten the turn and strut cover mounting fasteners (**Figure 5**) to 96-156 in.-lb. (11-18 N•m).

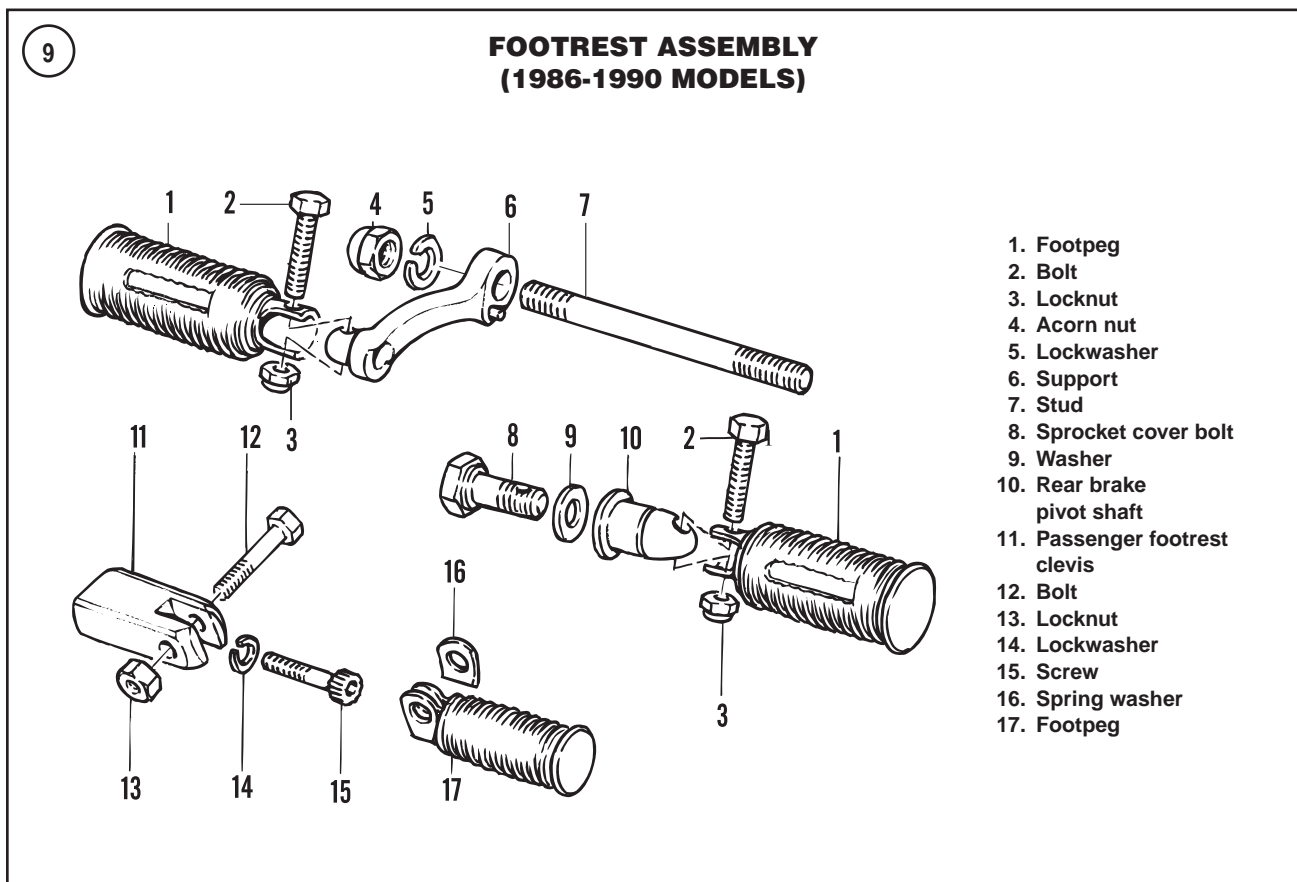
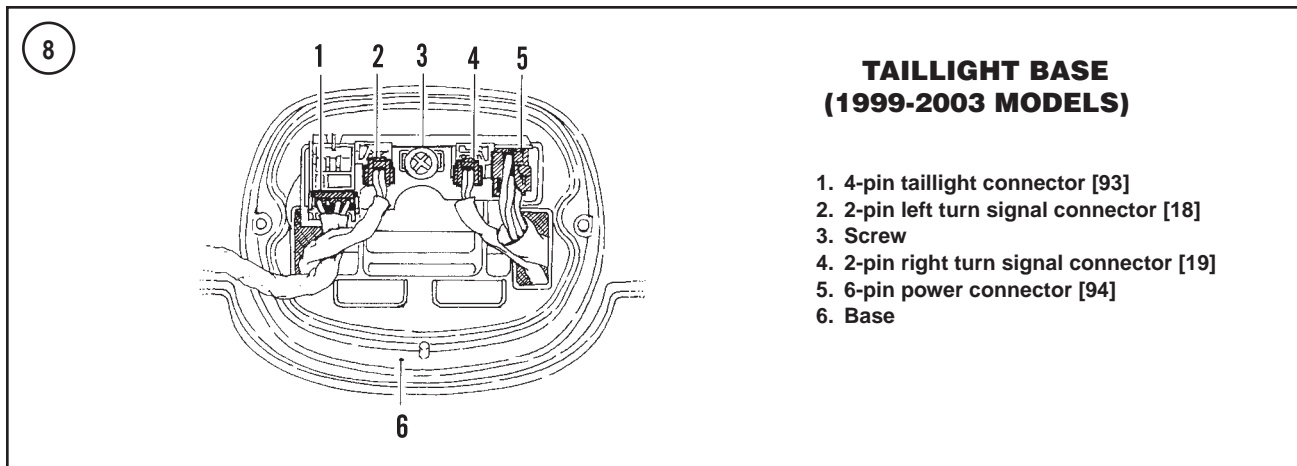

b. Install the fender mounting bolt (**Figure 7**) so the nut is on top. Tighten the nut to 120 in.-lb. (14 N•m).

FOOTRESTS

Removal/Installation

Refer to **Figure 9** or **Figure 10**.

1. Remove the footrest retaining bolt. On models so equipped, do not lose the spring washer between the footrest and clevis.

2. Remove the footrest.

3. Install the footrest by reversing the removal steps. Install the spring washer, if so equipped, so the square end is toward the motorcycle.

FORWARD FOOT CONTROLS (1999-2003 883C AND 1200C MODELS)

The shift and brake pedals are mounted on the left- and right-lower front engine mounting brackets. Both forward foot-control assemblies must be removed during engine re-

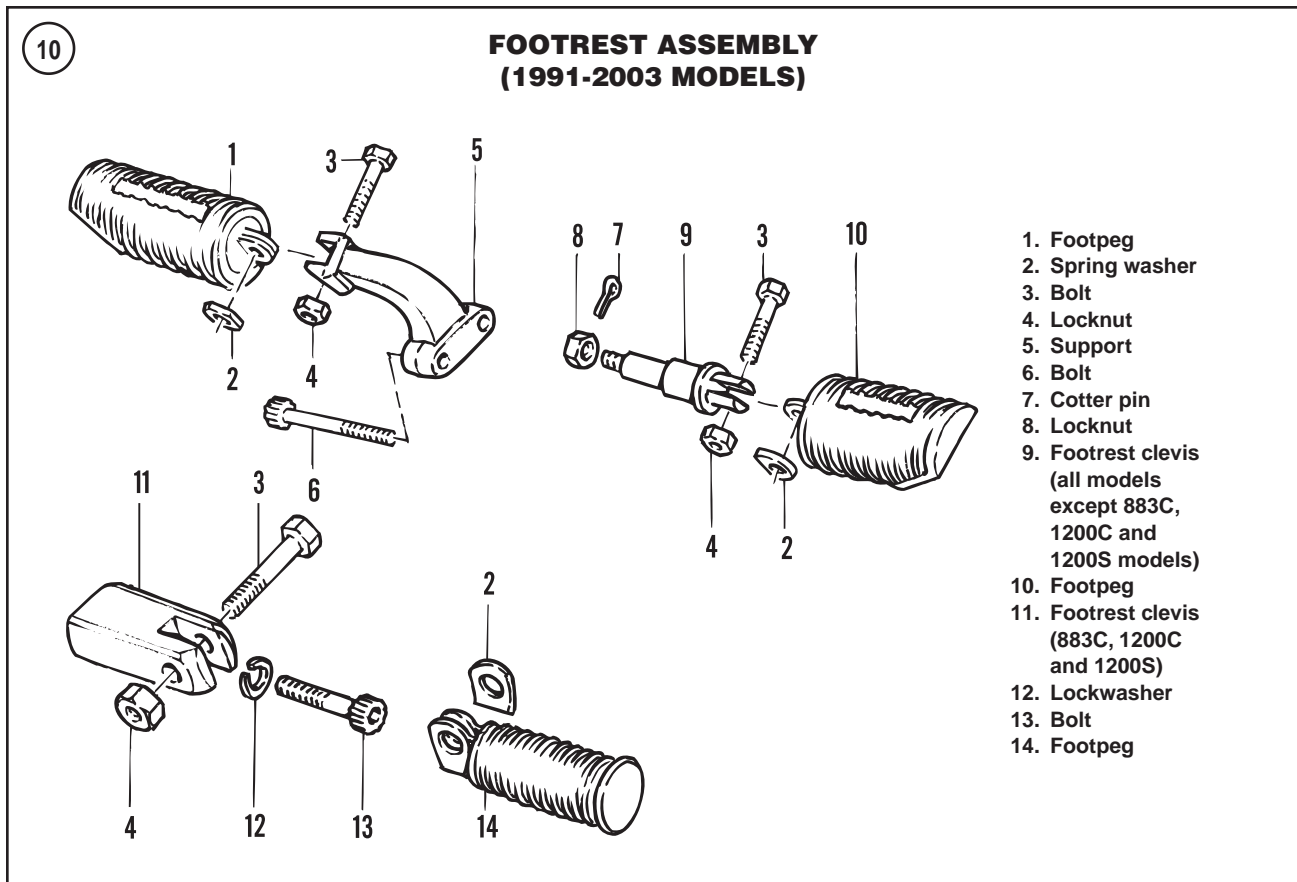

removal. Remove the controls as described in this chapter at the appropriate place during the engine removal procedure.

Refer to **Figure 11**.

Shift Pedal Removal/Installation

1. Remove the bolts and washers securing the shift rod to the shift lever and to the shift pedal, and then remove the shift rod.
2. Remove the two bolts securing the left engine-mounting bracket to the frame (A, **Figure 12**). Note the location of the P-clamp (B, **Figure 12**). The clamp must be reinstalled in the same location during assembly.
3. Remove the two bolts securing the left engine-mounting bracket to the engine (C, **Figure 12**), and remove the shift pedal mounting plate assembly.
4. If necessary, disassemble the shift pedal mounting plate assembly as described in this section.
5. Installation is the reverse of removal. Note the following:
 - a. Make sure the mounting plate is outboard of the frame mounting tabs.
 - b. Tighten the engine-mounting plate bolts to 25-30 ft.-lb. (34-41 N•m).
 - c. Tighten the shift-rod mounting bolts to 180 in.-lb. (20 N•m).

- d. If necessary, adjust the shift rod so the shift pedal is at a 45° angle relative to the ground (**Figure 13**).

Brake Pedal Removal/Installation

1. Remove the bolt, then remove the footrest from the footrest clevis.
2. Remove the clevis mounting bolts, then remove the footrest clevis from the footrest support.
3. Slide the brake pedal assembly from the footrest support.

CAUTION

The clevis pin that secures the brake rod to the brake pedal is pressed into place. It must not be removed. Do not try to separate the brake rod from the brake pedal.

4. Rotate the entire brake-pedal assembly counterclockwise, and unthread the brake rod from the master cylinder (**Figure 14**).
5. Pull the brake rod from the boot in the master cylinder, and remove the brake pedal assembly.
6. Remove the two bolts (**Figure 15**) securing the mounting plate to the frame, and then remove the bolts securing the plate to the engine. Remove the mounting plate.

11

FORWARD FOOT CONTROLS (1999-2003 883C AND 1200C MODELS)

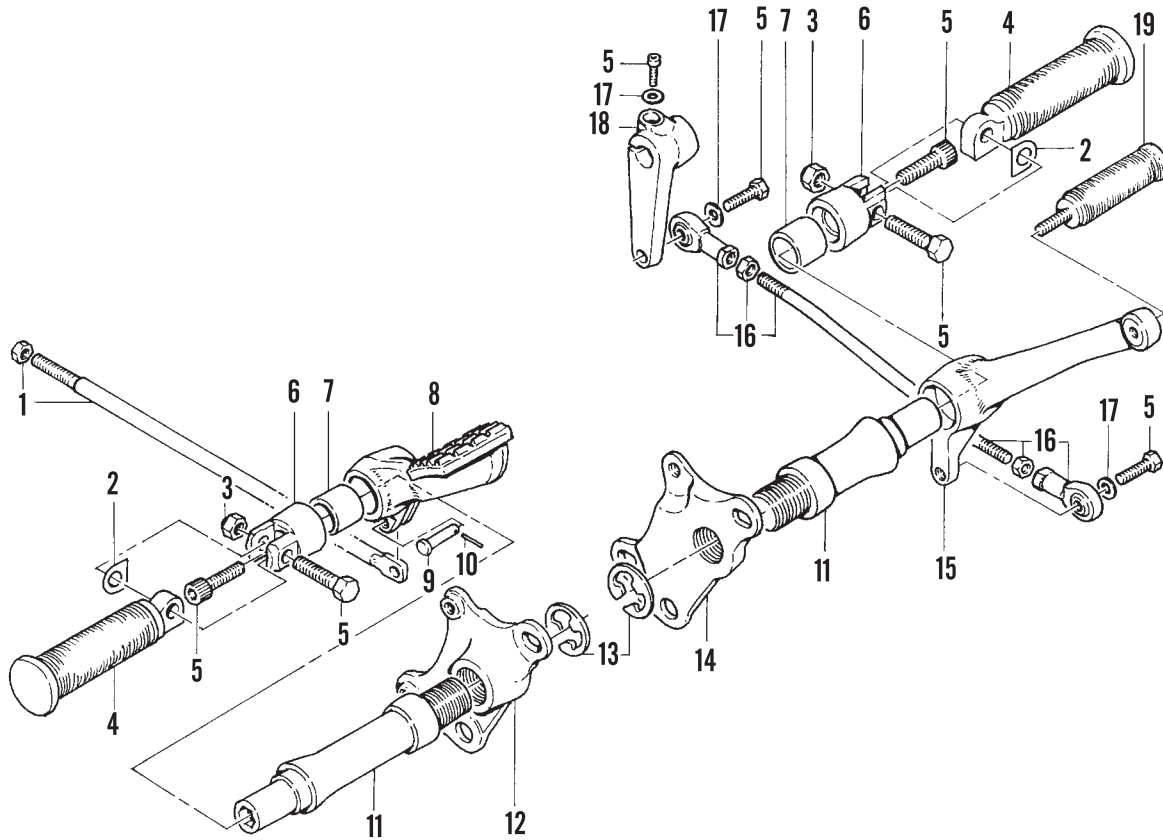

1. Brake rod
2. Spring washer
3. Nut
4. Footrest
5. Bolt
6. Footrest clevis
7. Bushing
8. Brake pedal
9. Clevis pin
10. Cotter pin
11. Footrest support
12. Right mounting plate
13. Circlip
14. Left mounting plate
15. Shift pedal
16. Shift rod
17. Washer
18. Shift lever
19. Shifter peg

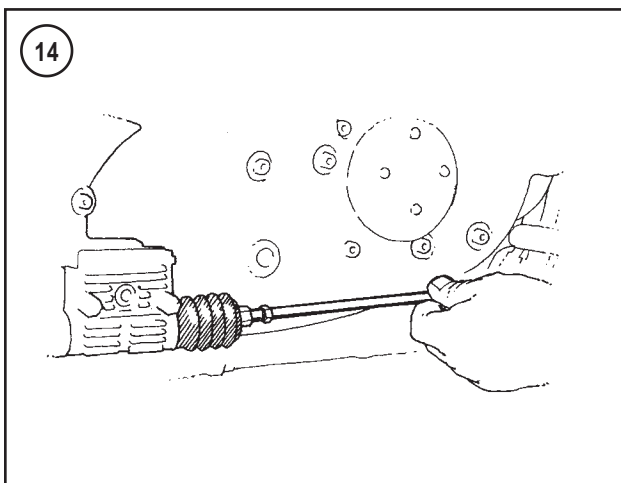
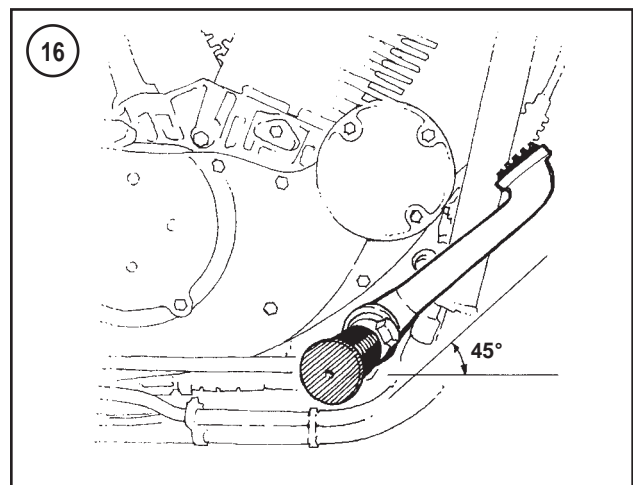
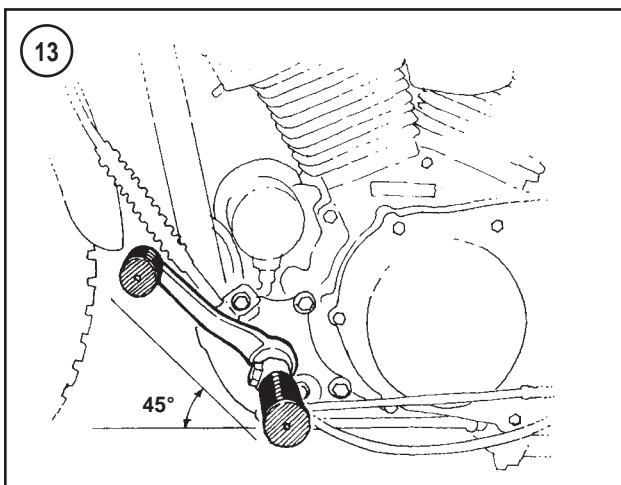
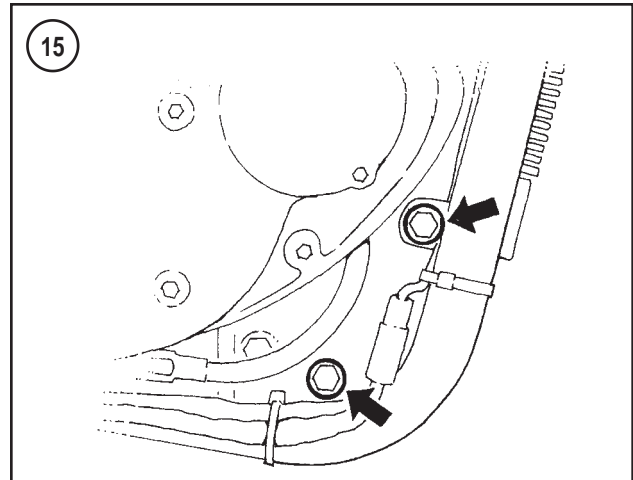
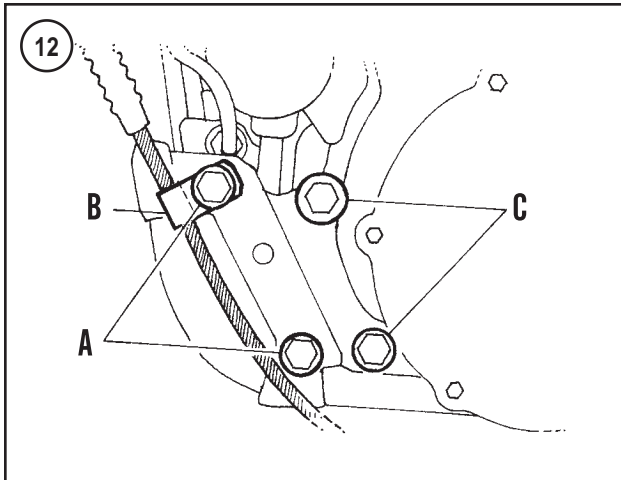

7. Installation is the reverse of removal. Note the following.

- a. Make sure the engine-mounting plate is inboard of the mounting tabs on the frame.
- b. Tighten the bolts to 25-30 ft.-lb. (34-41 N•m).
- c. Insert the brake rod through the master cylinder boot. Use the flats of the rod to turn the rod and thread it

into the master cylinder. Turn the brake rod/pedal assembly until the brake pedal can slide onto the footrest support.

- d. Apply threadlock (Loctite 243 or equivalent) to the clevis mounting bolt, and secure the footrest clevis to the footrest support. Tighten the clevis mounting bolt securely.
- e. Install the footrest onto the footrest clevis. Make sure the flat side of the spring washer faces the inside of the clevis.
- f. If necessary, adjust the brake rod length so the brake pedal is at a 45° angle relative to the ground. See **Figure 16**.

Shift Pedal/Mounting Bracket Disassembly/Assembly

1. Remove the shift pedal from the footrest support by performing the following:
 - a. Remove the securing bolt and remove the footrest from the footrest clevis. Account for the spring washer inside the clevis.

- b. Remove the clevis mounting bolt and remove the footrest clevis from the footrest support.
 - c. Slide the pedal assembly from the footrest support.
2. Remove the retaining clip, and unscrew the footrest support from the mounting plate.
 3. Assembly is the reverse of disassembly. Note the following:
 - a. Apply threadlock (Loctite 243 or equivalent) to the threads of the footrest support and screw the support securely into the engine mounting plate.
 - b. Secure the footrest support with a new retaining clip.
 - c. Apply threadlock (Loctite 243 or equivalent) to the threads of the clevis mounting bolts and tighten the bolt securely.
 - d. When installing the footrest onto the footrest clevis, make sure the flat side of the spring washer faces the inside of the clevis.

SIDESTAND

WARNING

The sidestand is spring-loaded. Exercise caution when working on the sidestand assembly.

Removal/Installation

1986-1988 models

Refer to **Figure 17**.

1. Place the motorcycle on a suitable stand so the sidestand can move freely without contacting the ground.
2. Raise the sidestand and disconnect the return spring.
3. Remove the bolt, lockwasher, washer and stop at the top of the sidestand and remove the sidestand from the leg bracket.
4. Check the sidestand for cracks or damage. Check the pivot area at the top of the sidestand for deep scoring, excessive wear or damage.
5. Check the return spring for fatigue, stretching, cracks or other damage. If the spring has not been holding the sidestand securely in its retracted position, replace it.
6. Check the spring supports for cracks, hole elongation or other damage.
7. Check the frame for damage.
8. Replace all worn or defective parts.
9. Installation is the reverse of these steps while noting the following:
 - a. Clean all the components.
 - b. Apply a light coat of multipurpose grease to the pivot surfaces on the sidestand and leg bracket.
 - c. Check sidestand operation. The sidestand is designed to lock when it is placed in its full down (or forward) position with the weight of the motorcycle resting on it. If the motorcycle is raised momentarily while the sidestand is in place, the sidestand may retract slightly from its full down position. Before resting

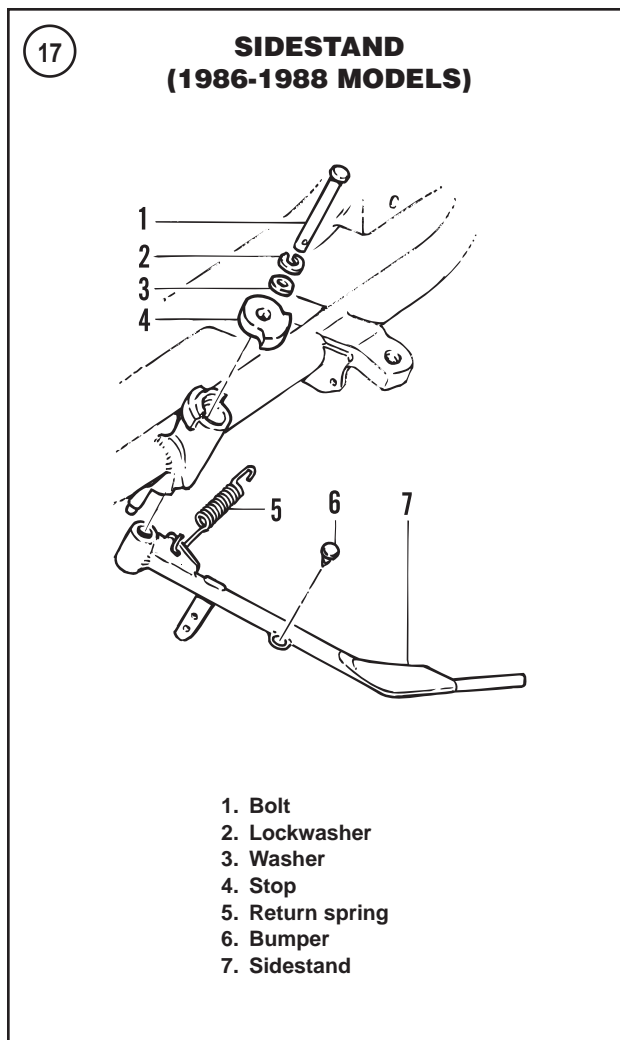

the weight of the motorcycle on the sidestand, make sure the sidestand is in its full down position. Make sure the sidestand retracts fully.

1989-2003 models

Refer to **Figure 18**.

1. Place the motorcycle on a suitable stand so the sidestand can be moved freely without contacting the ground.
2. Remove the rubber frame bumper to allow greater sidestand travel.
3. Place the sidestand in the retracted position.
4. Remove the cotter pin.
5. Hold the sidestand securely, then remove the pin from the upper mounting hole.
6. Disconnect the return spring.
7. Remove the sidestand.
8. Reverse the removal procedure to install the sidestand. Note the following:
 - a. Install the bushing so the shouldered end is down.

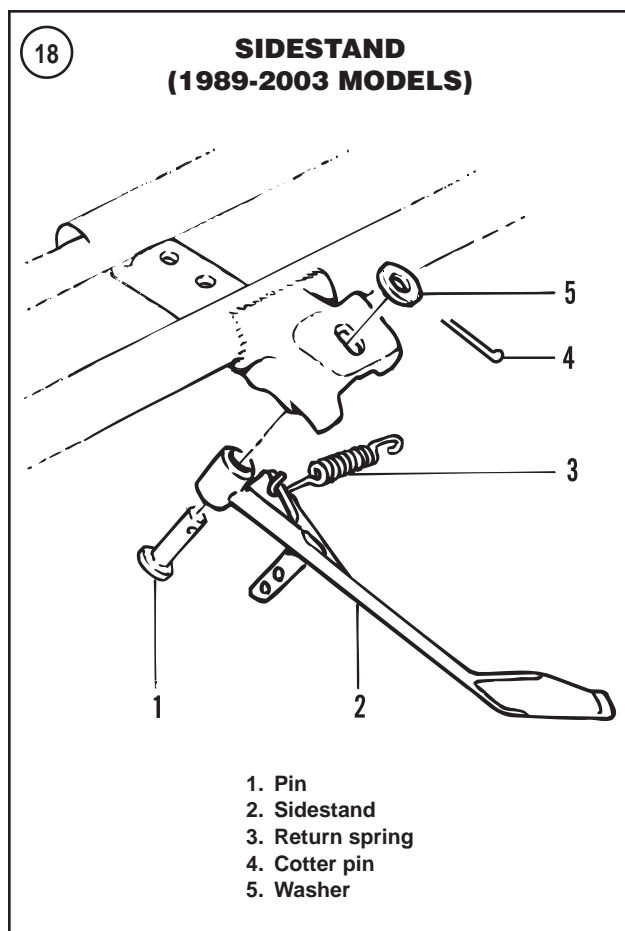

- b. Clean all components. Lubricate the clevis pin, spring mounting points and sidestand with bearing grease.
- c. Check sidestand operation. The sidestand is designed to lock when it is placed in its full down position with the weight of the motorcycle resting on it. If the motorcycle is raised momentarily while the sidestand is in place, the sidestand may retract slightly from its full down position. Before resting the weight of the motorcycle on the sidestand, make sure the sidestand is in its full down position. Make sure the sidestand retracts fully.



FORK LOCK

Replacement

1. Disconnect the negative battery cable from the crankcase (Chapter Twelve).
2. Remove the fuel tank (Chapter Ten or Chapter Eleven).

NOTE

Depending on the tools used, it may be necessary to remove or move handlebar components for access to the fork lock. Refer to Chapter Fourteen.

NOTE

Align the drill bit in Step 3 so it is centered on the lockpin. Misalignment will make lockpin removal difficult.

3. Using a 5/64-inch drill bit, drill a hole in the center of the lockpin (**Figure 19**, typical).
4. Install a screw extractor into the lockpin and pull out the lockpin.
5. Remove the lock assembly.
6. Install the new lock so the lockpin holes in the lock and frame are aligned.
7. Drive in a new lockpin so it is flush with the frame.
8. Check lockpin operation. Be sure the handlebar can be moved through a full range of motion.

Table 1 is on the following page.

Table 1 FRAME COMPONENT TORQUE SPECIFICATIONS

| | ft.-lb. | in.-lb. | N•m |
|--|----------------|----------------|------------|
| Engine-mounting plate bolts (883C and 1200C models) | 25-30 | – | 34-41 |
| Front fender locknuts | – | 96-156 | 11-18 |
| Rear fender front mounting bolt | – | 120 | 14 |
| Shift-rod mounting bolts (883C and 1200C models) | – | 180 | 20 |
| Strut cover bolts (1994-2003 models) | – | 96-156 | 11-18 |
| Turn signal bolts (1994-2003 models) | – | 96-156 | 11-18 |
| Turn signal mounting bolt (1986-1989 models) | 33 | – | 45 |
| Turn signal retaining nut (1990-1993 models) | – | 96-156 | 11-18 |

INDEX

A

- Air filter 139-140
 - backplate
 - 1986-1987 models 333
 - 1988-2003 models 350
- Alternator
 - 1986-1990 models 403-404
 - 1991-2003 models 404-408

B

- Battery
 - 1986-1996 models 393-398
 - 1997-2003 models 398-402
 - charging rates/times
 - approximate 464
- Body
 - fender
 - front 590-591
 - rear 591-594
 - footrests 594
 - fork lock 599
 - forward foot controls,
 - 1999-2003 883C
 - and 1200C models 594-598

- seat 590
- sidestand 598-599
- torque 600
- Brake
 - adjustment 131
 - bleeding the system 586-588
 - caliper
 - front
 - 1986-1999 models 540-544
 - 2000-2003 models 545-548
 - caliper
 - rear
 - 1986-early 1987 models .. 567-569
 - late 1987-1999 models ... 569-572
 - 2000-2003 models 572-575
 - disc front and rear 584-586
 - fluid,
 - change 131
 - draining 588-589
 - level inspection 129-130
 - selection 533
 - flushing the brake system 589
 - front brake lever pivot pin
 - lubrication 123
 - hose and line replacement ... 581-584
 - inspection 129-130

- light switch
 - front 446-447
 - rear 450
- master cylinder
 - front
 - 1986-1995 models 548-552
 - 1996-2003 models 552-557
 - rear
 - 1986-early 1987 models .. 575-577
 - late 1987-2003 models ... 577-581
- pads
 - front
 - 1986-1999 models 535-538
 - 2000-2003 models 538-540
 - inspection 129
 - rear
 - 1986-early 1987 models .. 557-561
 - 2000-2003 models 565-567
 - late 1987-1999 models ... 561-565
- service 533-535
- specifications 589
- torque 589
- troubleshooting 111

C

Carburetor 333-340, 350-366
 specifications
 1986-1987 models 349
 1988-2003 models 390
 Charging system,
 troubleshooting 41-44
 Choke cable adjustment
 (1986-1987 models) 136
 Clutch
 adjustment 131-134
 1986-1990 models 254-261
 clutch cable 261-262
 lever pivot pin lubrication 123
 release mechanism 252-254
 1991-2003 models 271-279
 clutch cable 279-283
 release mechanism
 1991-1993 models 269
 1994-2003 models 269-270
 specifications
 1986-1990 models 262
 1991-2003 models 283
 torque
 1986-1990 263
 1991-2003 283
 troubleshooting 90
 Compression test 140-141
 Control cables
 (non-nylon lined) 122-123
 Crankcase and crankshaft 233-246
 Cylinder 179-184
 head 157-169
 stud 246-247

D

Diagnostic trouble codes 57-58
 Drive belt and sprocket 483-487
 periodic maintenance 127-128
 adjustment 128
 Drive chain and sprocket 479-483
 periodic maintenance 125-127
 adjustment 125
 lubrication 123-124

E

Electrical
 alternator
 1986-1990 models 403-404
 1991-2003 models 404-408
 bank angle sensor,
 1998-2003 models 418
 battery
 1986-1996 models 393-398
 1997-2003 models 398-402
 charging rates/times
 (approximate) 464
 charging system 402-403

circuit breakers,
 1986-1997 models 456-457
 component replacement 392
 troubleshooting 35
 connectors 392-393
 service 457-463
 electrical bracket 452-453
 electronic speedometer/
 tachometer 437-440
 fundamentals 17-18
 fuses, 1998-2003 models 457
 horn 450-452
 ignition system
 1986-1997 models 408-412
 1998-2003, except
 1200S models 412-414
 1998-2003, 1200S models 414-417
 ignition coil 417-418
 lighting system 426-437
 MAP sensor,
 1998-2003 1200S models 418-419
 specifications 112, 463-464
 starter 419-425
 starter motor, specifications 464
 starter solenoid 425-426
 switches 440-450
 torque 465
 troubleshooting, testing 91-95
 turn signal
 flasher, 1986-1990 models 453-454
 module, 1991-2003 models 454-456
 wiring diagrams 606-629
 Electronic speedometer/
 tachometer 437-440
 troubleshooting 95-101
 Emission control
 1986-1987 models
 evaporative emission control
 system, California models 347-348
 throttle and idle cable
 replacement 342-343
 1988-2003 models
 evaporative emission control
 system, California models 378-389
 throttle and idle cable
 replacement 368-370
 torque 349
 Engine
 installation 202-210
 lower end
 break-in 247
 crankcase and crankshaft 233-246
 cylinder, stud 246-247
 engine 197-202
 flywheel end play shim
 thickness 249
 gearcase, cover and
 timing gears 214-221
 installation 202-210
 oil
 and filter change 117-119
 filter mount
 1986-1990 models 231-232

1991-2003 models 232-233
 level check 115
 pump 228-231
 1986-1990 models 221-228
 service 197, 248-249
 stand 197
 tools 197
 torque 249-250
 valve, tappets and guides
 1986-1990 models 210-212
 1991-2003 models 213-214
 oil, specifications 149
 primary drive/transmission oil,
 capacities 149
 removal 197-200
 top end
 cylinder 179-184
 head 157-169
 oil
 tank and lines 190-192
 pistons and piston rings 184-189
 pushrods and covers 175-179
 rocker cover assembly 151-157
 service 193-195
 specifications 193
 tools 151
 torque 196
 valve
 spring compression 195
 valves and valve
 components 169-175
 troubleshooting
 lubrication 90
 noises 88
 performance 34-35
 smoke 89
 starting 32-34
 Evaporative emission control system,
 California models 347-348
 1988-2003 378-389
 Exhaust system
 1986-1987
 air filter, backplate 333
 exhaust system 347
 1988-2003
 air filter, backplate 350
 1988-2003, except
 883R models 375-378
 torque 391
 1988-2003, 883R models 378
 inspection 137
 torque 349

F

Fasteners 4-6
 Fork oil change 121-122
 Fuel
 1986-1987 models
 carburetor 333-340
 specifications 349
 choke cable 343

- fuel
 - hose and clamps 342
 - shutoff valve 344-347
 - tank 344
 - intake manifold 340-342
 - 1988-2003 models
 - carburetor 350-366
 - specifications 390
 - fuel
 - hose and clamps 367-368
 - shutoff valve
 - 1988-1994 models 373-375
 - 1995-2003 models 375
 - tank 370-373
 - intake manifold 366-367
 - starting enrichment valve
 - (choke) cable replacement 370
 - torque 391
 - fuel tank capacity 26-27
 - line inspection 137
 - torque 349
 - troubleshooting 60-88
 - type 113
 - Fuses, 1998-2003 models 457
- G**
- Gearcase,
 - cover and timing gears 214-221
 - General information
 - American tap and drill sizes 29
 - conversion tables 27-28
 - decimal and metric equivalents 30
 - electrical system, fundamentals 17-18
 - fasteners 4-6
 - fuel tank capacity 26-27
 - general dimensions 24-26
 - gross vehicle weight rating (gvwr) 26
 - manual organization 1
 - metric tap and drill sizes 29
 - model designations 24
 - overall motorcycle weight 26
 - safety 2-3
 - serial numbers 3
 - service methods 18-23
 - shop supplies 6-8
 - storage 23-24
 - technical abbreviations 28-29
 - tools 8-12
 - measuring tools 12-17
 - special tools 18, 30-31
 - torque 27
 - warnings, cautions and notes 2
- H**
- Horn 450-452
- I**
- Ignition module replacement 58
- Ignition system
 - 1986-1997 models 408-412
 - troubleshooting 44-51
 - 1998-2003 models
 - except 1200S models 414-417
 - troubleshooting 51-56
 - 1998-2003 1200S models 412-414
 - troubleshooting 56-60
 - idle speed adjustment 146-147
 - ignition coil 417-418
 - switch 447-448
 - timing
 - adjustment 144-147
 - specifications 150
 - Intake manifold 340-342
- L**
- Laced wheels 488-489
 - Leakdown test, troubleshooting 89-90
 - Lighting system 426-437
 - switch 447-448
 - Lubrication
 - control cables
 - (non-nylon lined) 122-123
 - clutch lever pivot pin 123
 - drive chain 123-124
 - engine
 - oil
 - and filter change 117-119
 - level check 115
 - specifications 149
 - primary drive/transmission
 - oil capacities 149
 - fork oil
 - capacity 149
 - change 121-122
 - front brake lever pivot pin 123
 - periodic 114-124
 - recommended lubricants and
 - fluids 149
 - sidestand 124
 - throttle control grip 123
 - transmission
 - oil 119-121
 - capacities 149
 - speedometer cable
 - (1986-1994 models) 124
 - steering head 124
- M**
- Maintenance
 - fuel, type 113
 - periodic 124-138
 - routine safety checks 113-114
 - schedule 113, 147-148
 - specifications 150
 - tire
 - inflation pressure, cold 149
 - tires and wheels 114
 - torque 150
- Model designations 24
- O**
- Oil
 - and filter changer 117-119
 - filter mount
 - 1986-1990 models 231-232
 - 1991-2003 models 232-233
 - level check 115
 - pump 228-231
 - 1986-1990 models 221-228
 - pressure switch 449
 - specifications 149
 - tank and lines 190-192
 - inspection 115
 - transmission 119-121
- P**
- Pistons and piston rings 184-189
 - Primary drive
 - 1986-1990 models 254-261
 - cover 251-252
 - primary chain adjuster 254
 - 1991-2003 271-279
 - cover
 - 1991-1993 models 264-266
 - 1994-2003 models 267-269
 - primary chain
 - adjuster 271
 - adjustment 124-125
 - Periodic
- S**
- Secondary drive
 - drive belt and sprockets 483-487
 - drive chain and sprockets 479-483
 - motorcycle stands 466
 - Sidestand 598-599
 - lubrication 124
 - Spark plugs 141-144
 - Spark test 32-33
 - Speedometer/tachometer 437-440
 - cable lubrication
 - (1986-1994 models) 124
 - Specifications
 - brake 589
 - carburetor
 - 1986-1987 models 349
 - 1988-2003 models 390
 - clutch
 - 1986-1990 models 262
 - 1991-2003 models 283
 - electrical 112, 463-464
 - engine, top end 193
 - ignition, timing 150
 - maintenance 150
 - oil 149
 - starter motor 112, 464

- Specifications (continued)
 transmission, five-speed,
 1991-2003 models 331-332
 tune-up 150
 wheels, front and rear 496
- Starting enrichment valve (choke)
 cable adjustment
 (1988-2003 models) 137
- Starter 419-425
 motor, specifications 112
 solenoid 425-426
 system, troubleshooting 35-41
- Steering
 head lubrication 124
 steering head and stem 518-522
 steering head bearing 522-523
 steering play adjustment 523-524
- Storage 23-24
- Suspension
 front
 and steering,
 troubleshooting 104-111
 front fork
 1200S models 510-518
 specifications 524
 except 1200S models 503-510
 oil capacity 524
 handlebar 500-503
 torque 524-525
 rear
 rear swing arm 528-532
 shock absorbers 526-528
 torque 499
 rear 532
- Switches 440-450
 brakelight
 front 446-447
 rear 450
 handlebar 441-446
 ignition/lighting 447-448
 oil pressure 449
 testing 440
- T**
- Throttle cables 135-136
 Throttle control grip lubrication 123
 Tire 490-495
 and wheels 114
 inflation pressure 496
 cold 149
- Tools 8-12
 engine
 lower end 197
 top end 151
 measuring tools 12-17
 special tools 18, 30-31
- Torque
 body 600
 brake 589
 clutch
 1986-1990 models 263
 1991-2003 models 283
- electrical 465
 emission control 349
 engine
 lower end 249-250
 top end 196
 exhaust system
 1986-1987 models 349
 1988-2003 models 391
- fuel
 1986-1987 models 349
 1988-2003 models 391
 general 27
 maintenance 150
 suspension
 front 524-525
 rear 532
- transmission
 five-speed, 1991-2003 models 332
 four-speed, 1986-1990 models 303
 tune-up 150
 wheels 499
- Transmission
 five-speed,
 1991-2003 models 304-308
 access door bearings 328-329
 main drive gear 323-328
 mainshaft and countershaft 312-323
 right transmission case
 bearings 329-330
 shift forks and shift drum 308-312
 shift mechanism 330
 specifications 331-332
 torque 332
 four-speed, 1986-1990 models 284-296
 countershaft end play thrust
 washer selection 303
 countershaft gear spacer
 selection chart 302
 countershaft washers 302
 early and late style gear
 outside diameters 301
 gear ratios 301-302
 mainshaft end play thrust
 washer selection 303
 service 301
 shifter mechanism 296-300
 torque 303
 oil 119-121
 neutral indicator switch 449-450
 troubleshooting 90-91
- Troubleshooting
 brake 111
 charging system 41-44
 clutch 90
 electrical
 component replacement 35
 specifications 112
 testing 91-95
 electronic speedometer/
 tachometer 95-101
 engine
 lubrication 90
 noises 88
- performance 34-35
 smoke 89
 starting 32-34
 excessive vibration 104
 fuel system 60-88
 ignition system
 1986-1997 models 44-51
 1998-2003 models, except
 1200S models 51-56
 1998-2003 1200S models 56-60
 leakdown test 89-90
 starting system 35-41
 suspension, front and
 steering 104-111
- Troubleshooting, transmission 90-91
 turn signal module
 1997-2003 models 104
 1991-1996 models 101-104
 starter motor, specifications 112
 Tune-up 139
 air filter 139-140
 compression test 140-141
 ignition timing
 adjustment 144-147
 specifications 150
 spark plug 141-144
 specifications 150
 torque 150
- Turn signal
 module
 1991-2003 models 454-456
 1991-1996 models,
 troubleshooting 101-104
 1997-2003 models,
 troubleshooting 104
 flasher, 1986-1990 models 453-454
- V**
- Valve
 tappet, 1991-2003 models 213-214
 tappets and guides,
 1986-1990 models 210-212
 valves and valve
 components 169-175
- W**
- Wheels
 balance 490
 disc and cast wheels 489-490
 front wheel 466-469
 bearing spacer shims,
 late 1991-1999 models 496
 bearing spacer sleeves
 1986-early 1991 models 496
 hub
 front
 1986-1999 models 469-473
 2000-2003 models 473-474
 rear
 1986-1999 models 476-479
 2000-2003 models 479

- Wheel (continued)
- laced 488-489
 - truing 488-489
 - rear wheel 474-476
 - bearing spacer shims,
 - late 1991-1999 models 497
 - bearing spacer sleeves
 - cast wheel,
 - 1986-early 1991 models 496
 - laced wheel,
 - 1986-early 1991 models 497
 - rim and laced wheel service . . . 488-489
 - runout 487
 - specifications, front and rear 496
 - torque 499
 - tubeless tire, specifications
 - 1986 models 497
 - 1987-1990 models 497
 - 1991-2003 models 497-498
 - tube-type tire, specifications
 - 1986-1990 models 498
 - 1991-2003 models 498
 - torque 499
 - truing 488-489

Wiring diagrams 606-629

1986-1990 ALL MODELS

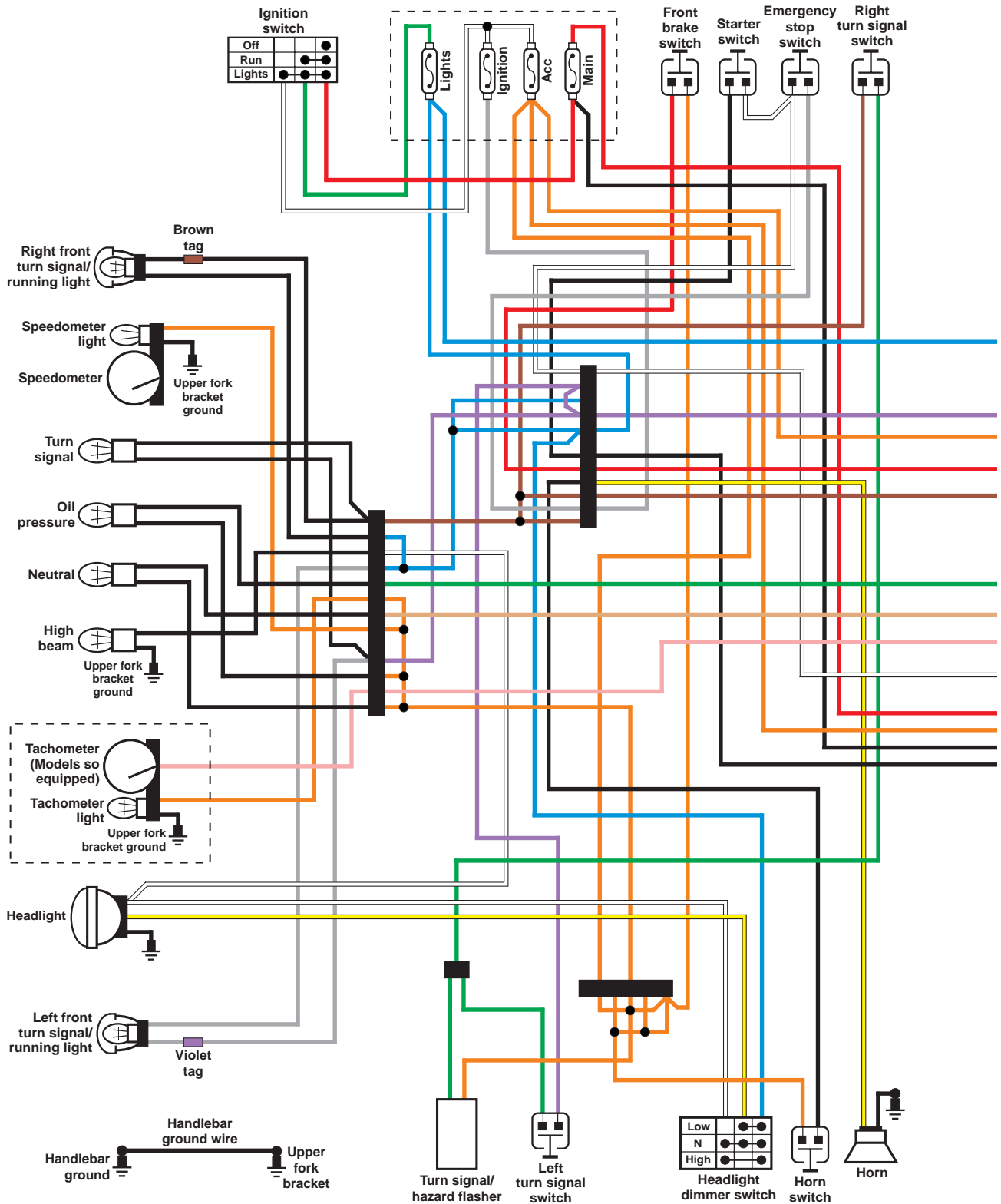

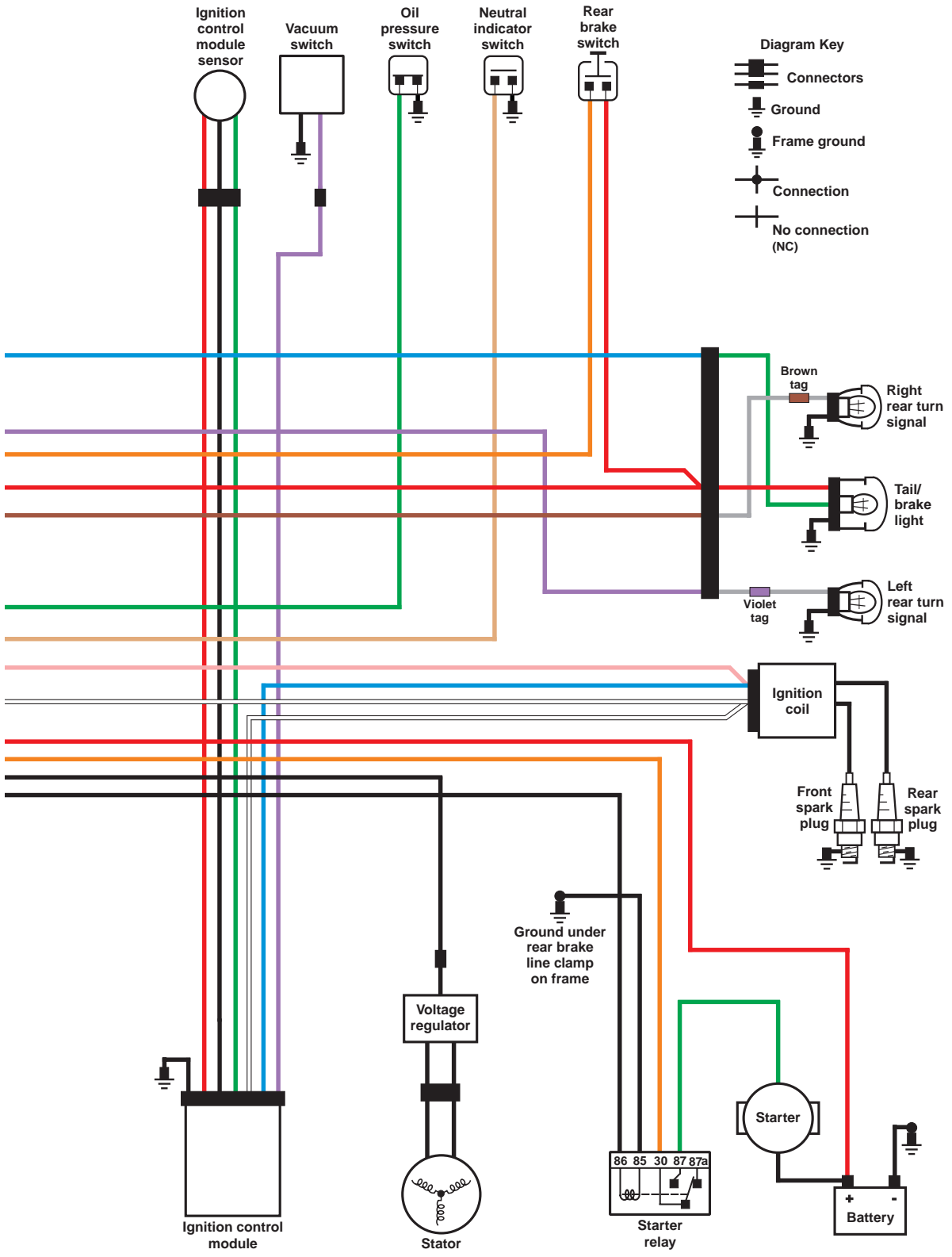

1991-1993 ALL MODELS (EXCEPT HDI MODELS)

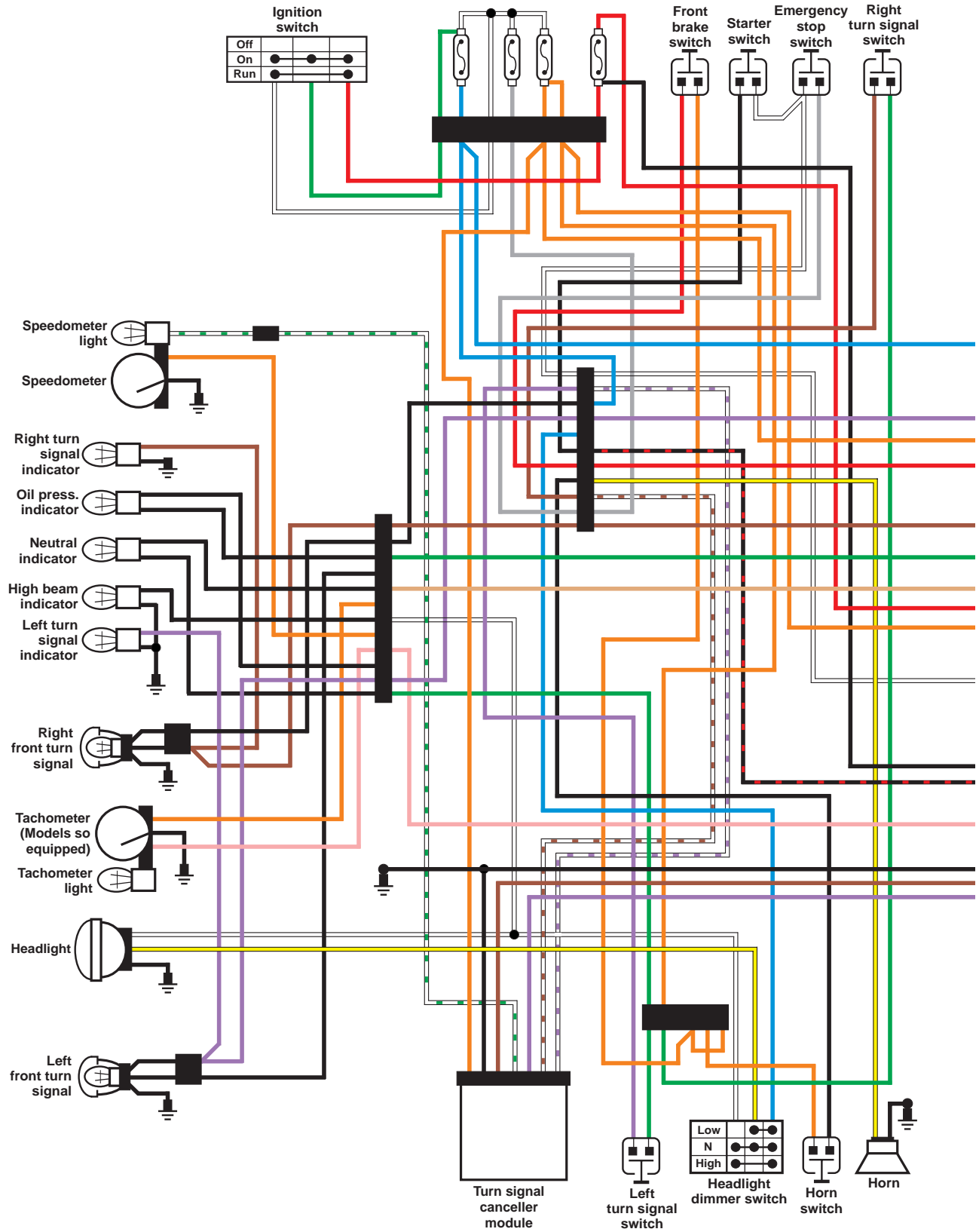

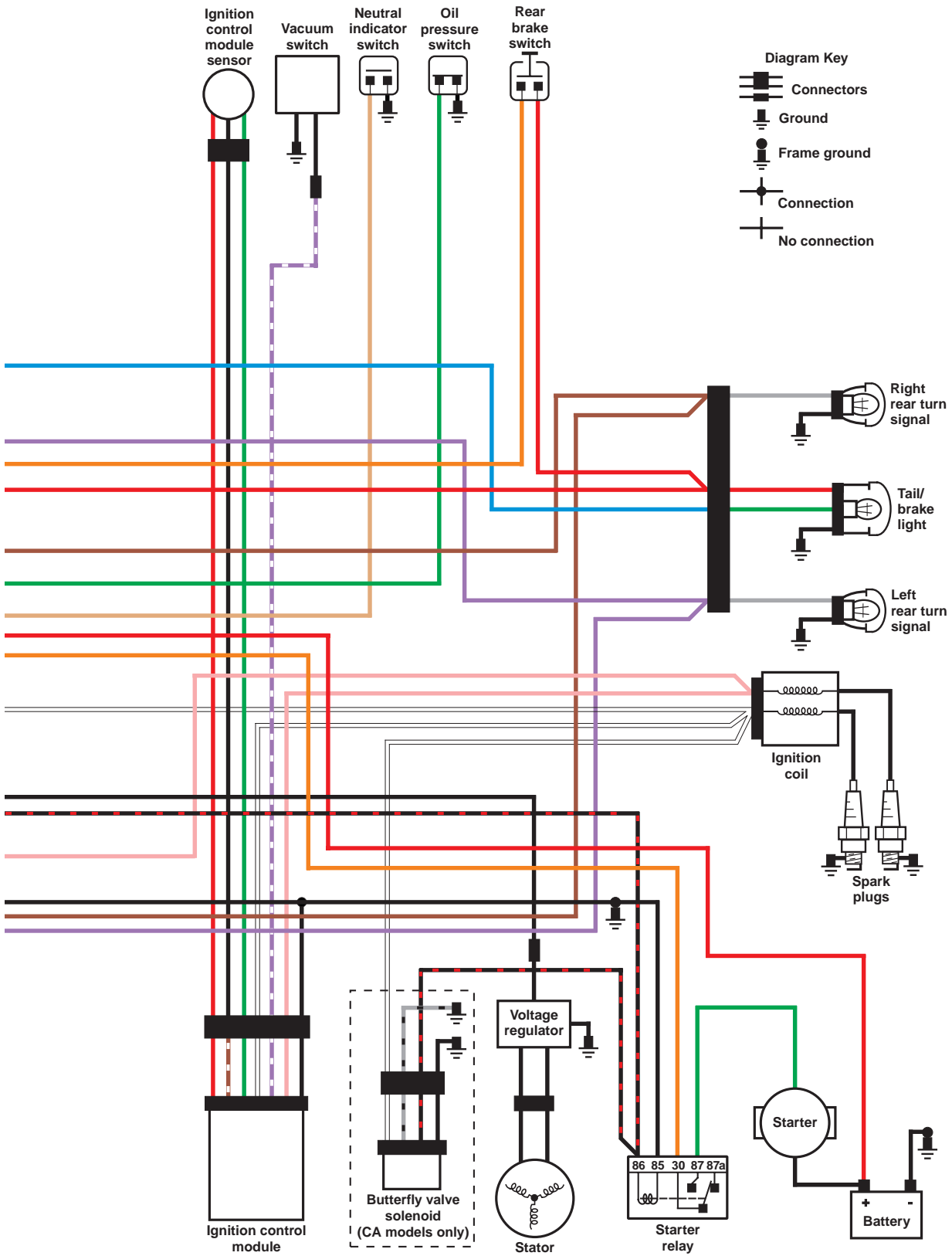

1991-1993 HDI MODELS

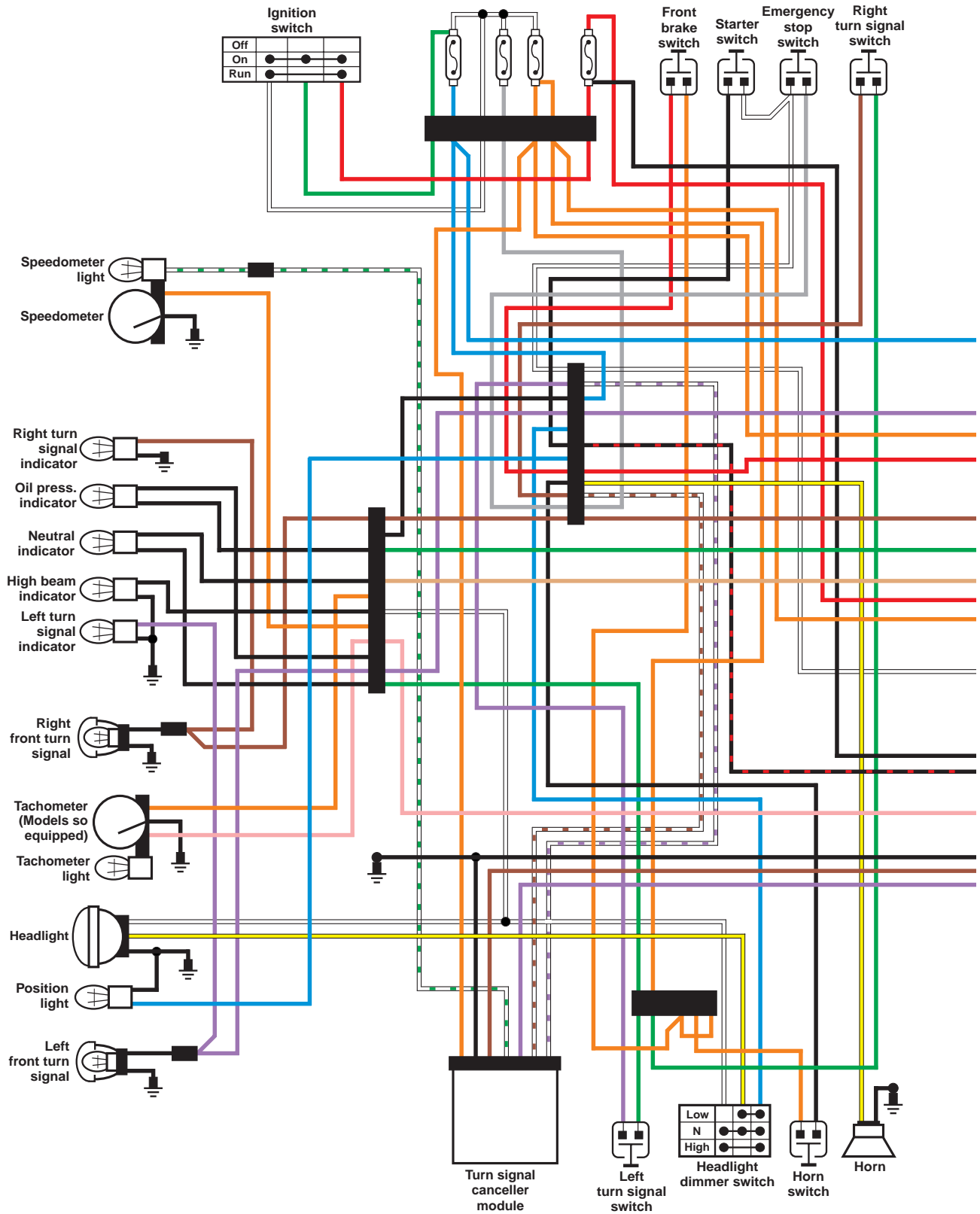

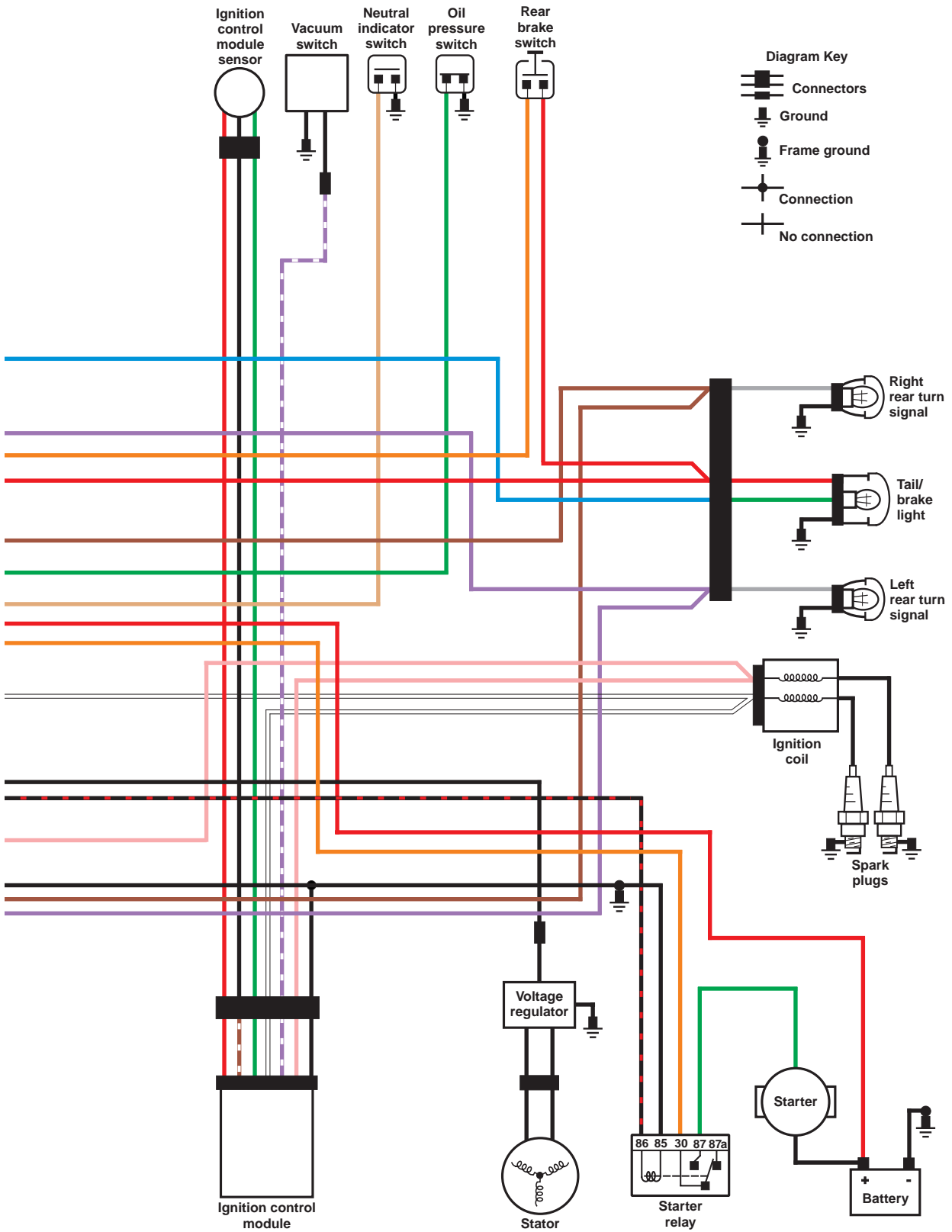

1994-1996 ALL MODELS (EXCEPT 1996 1200C MODELS)

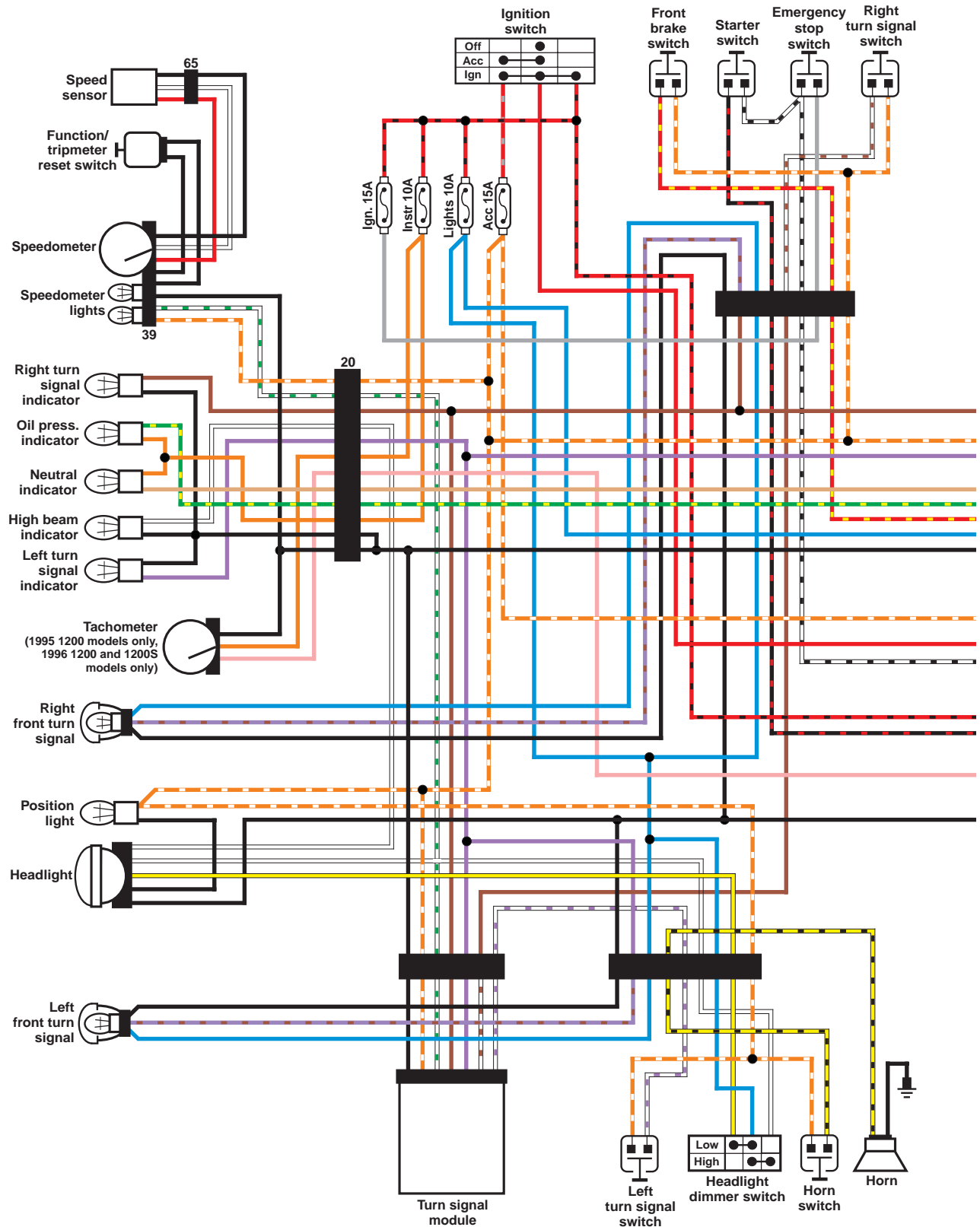

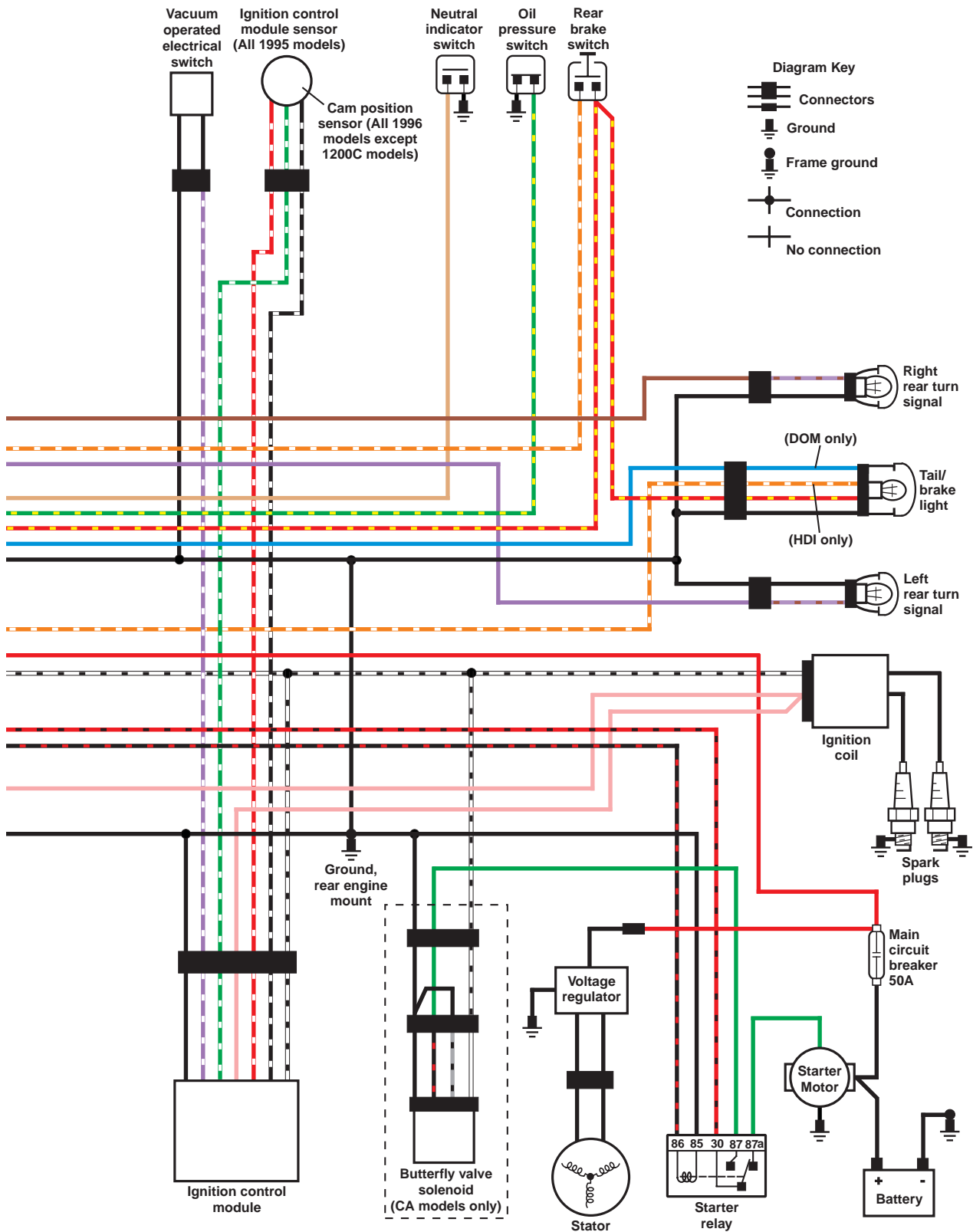

1996 1200C MODELS

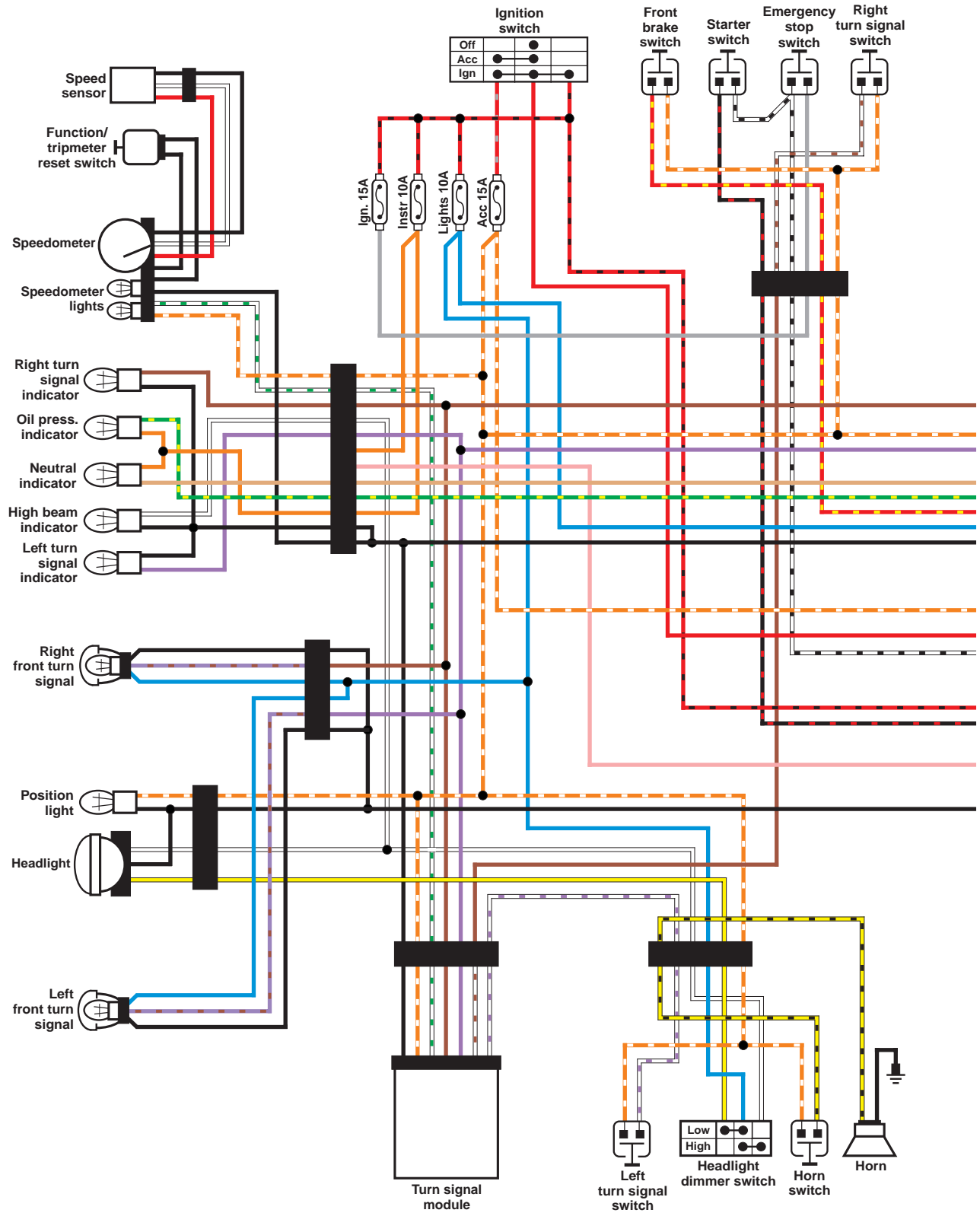

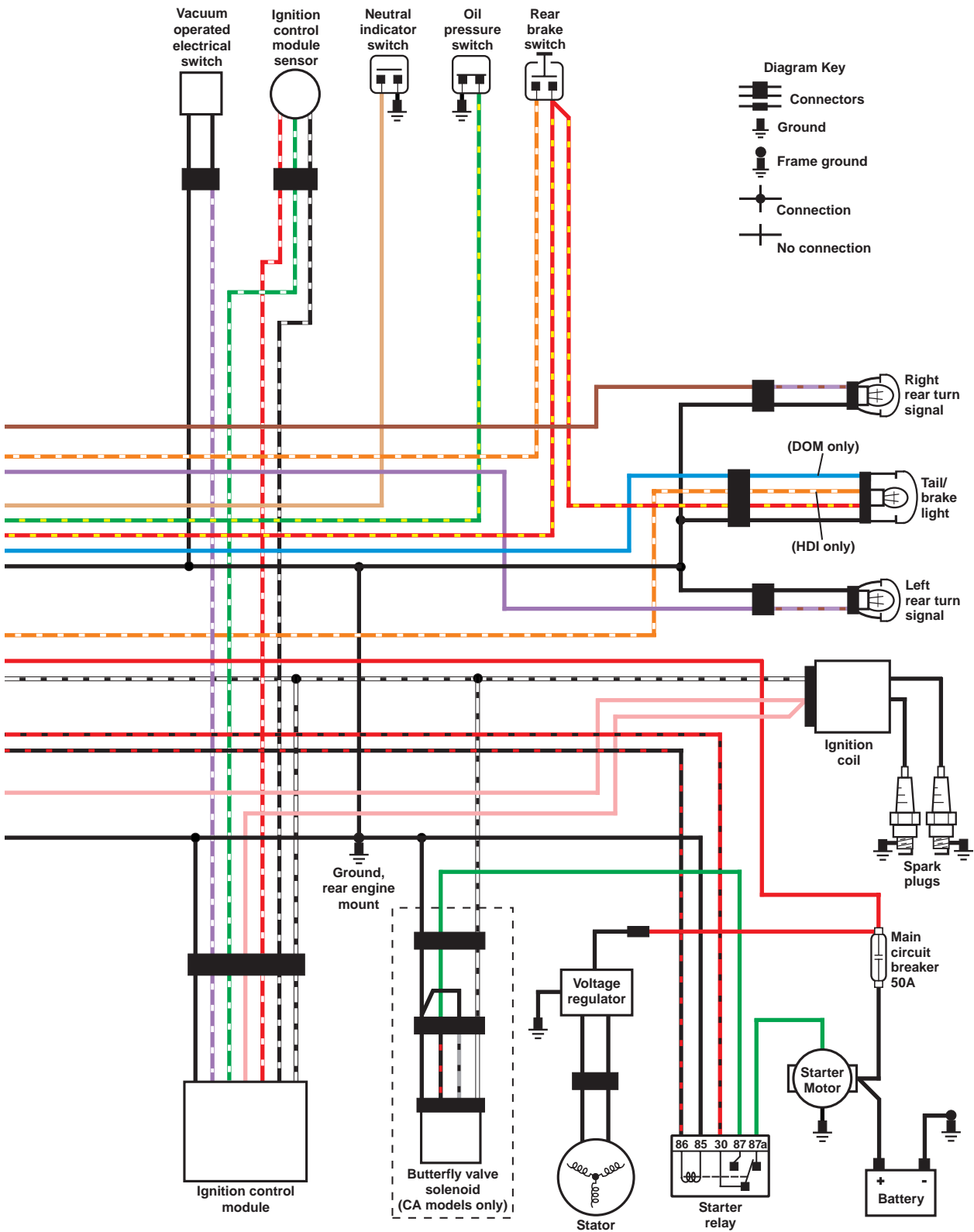

1997 ALL MODELS

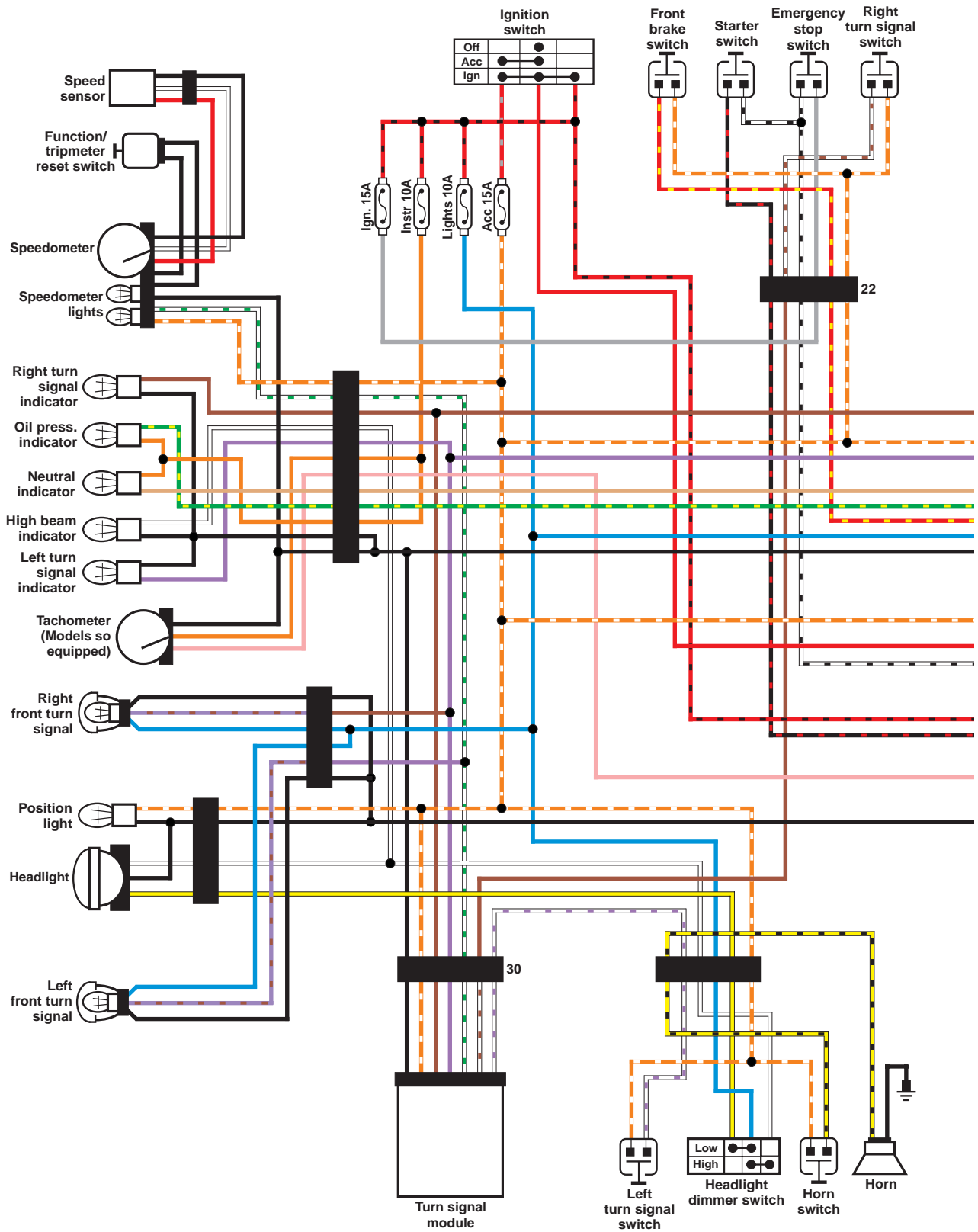

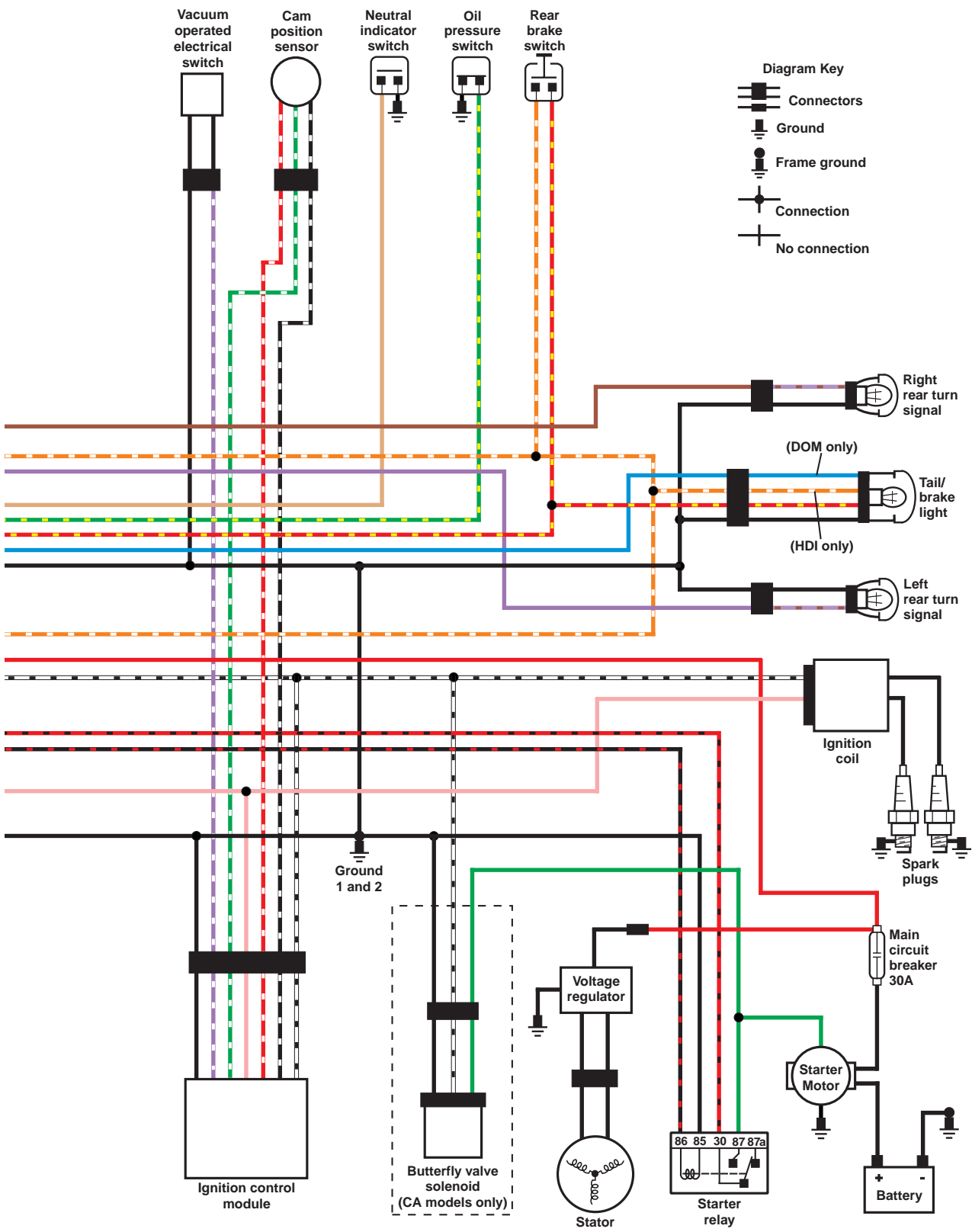

1998 ALL MODELS (EXCEPT 1200S MODELS)

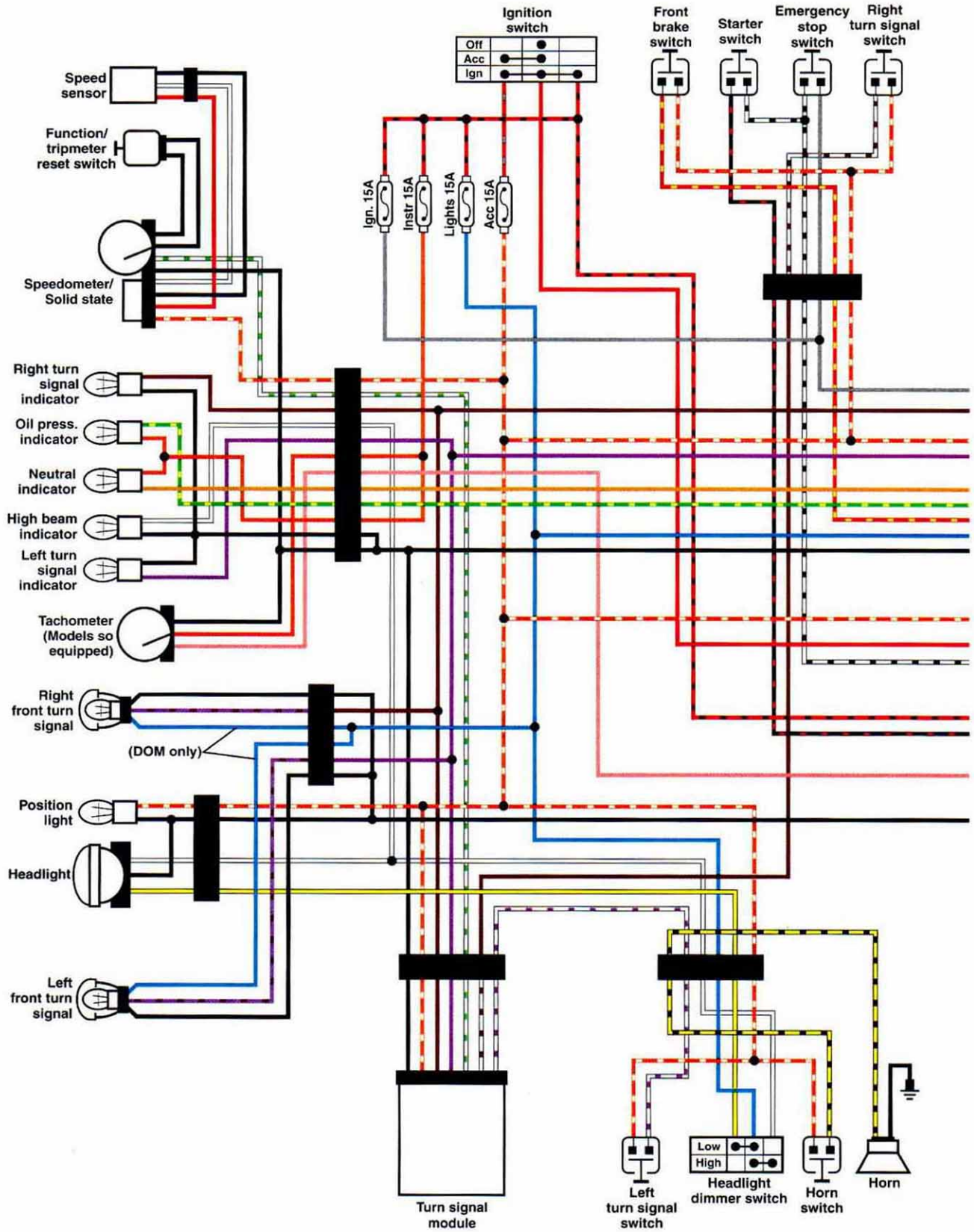

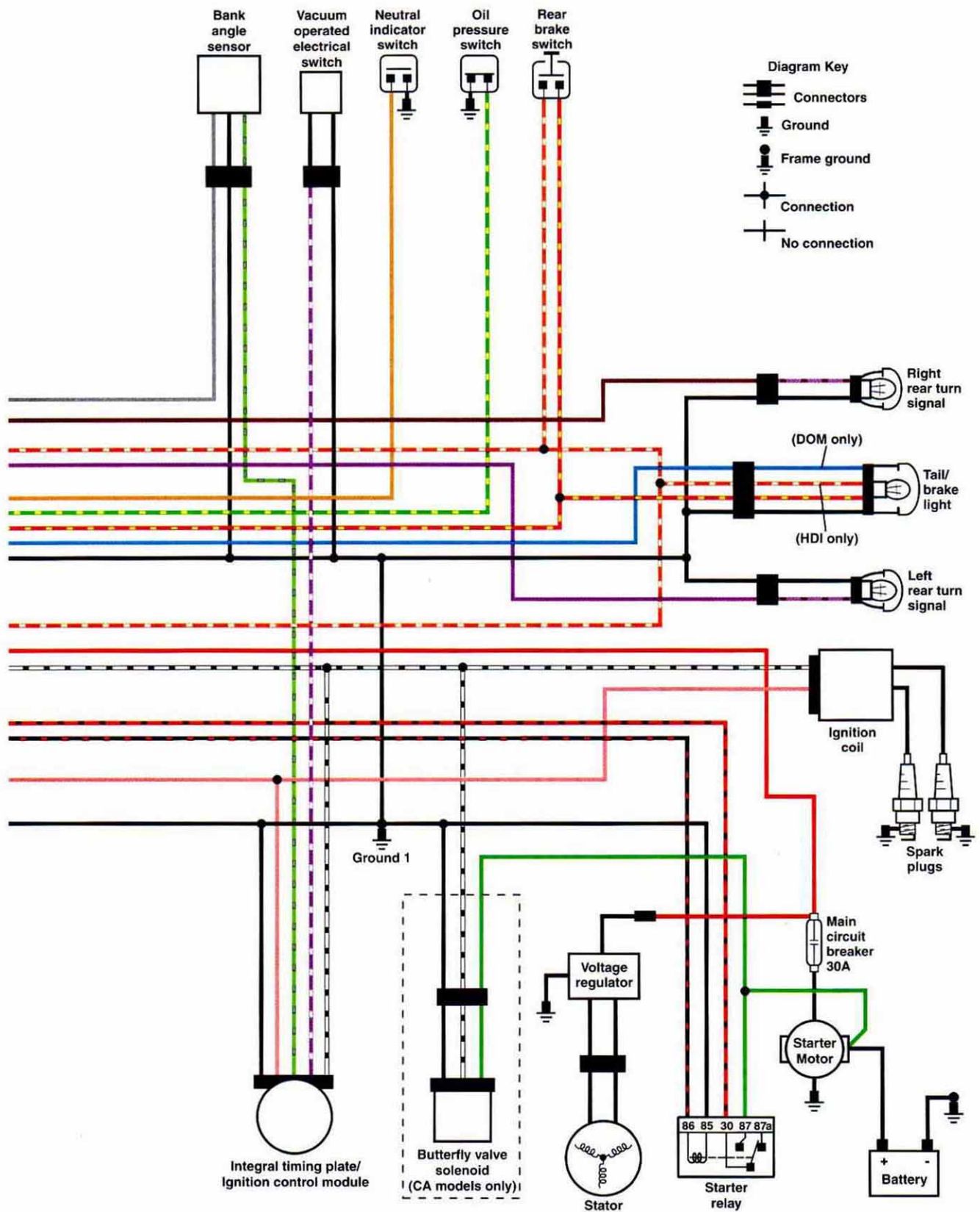

1998 1200S MODELS

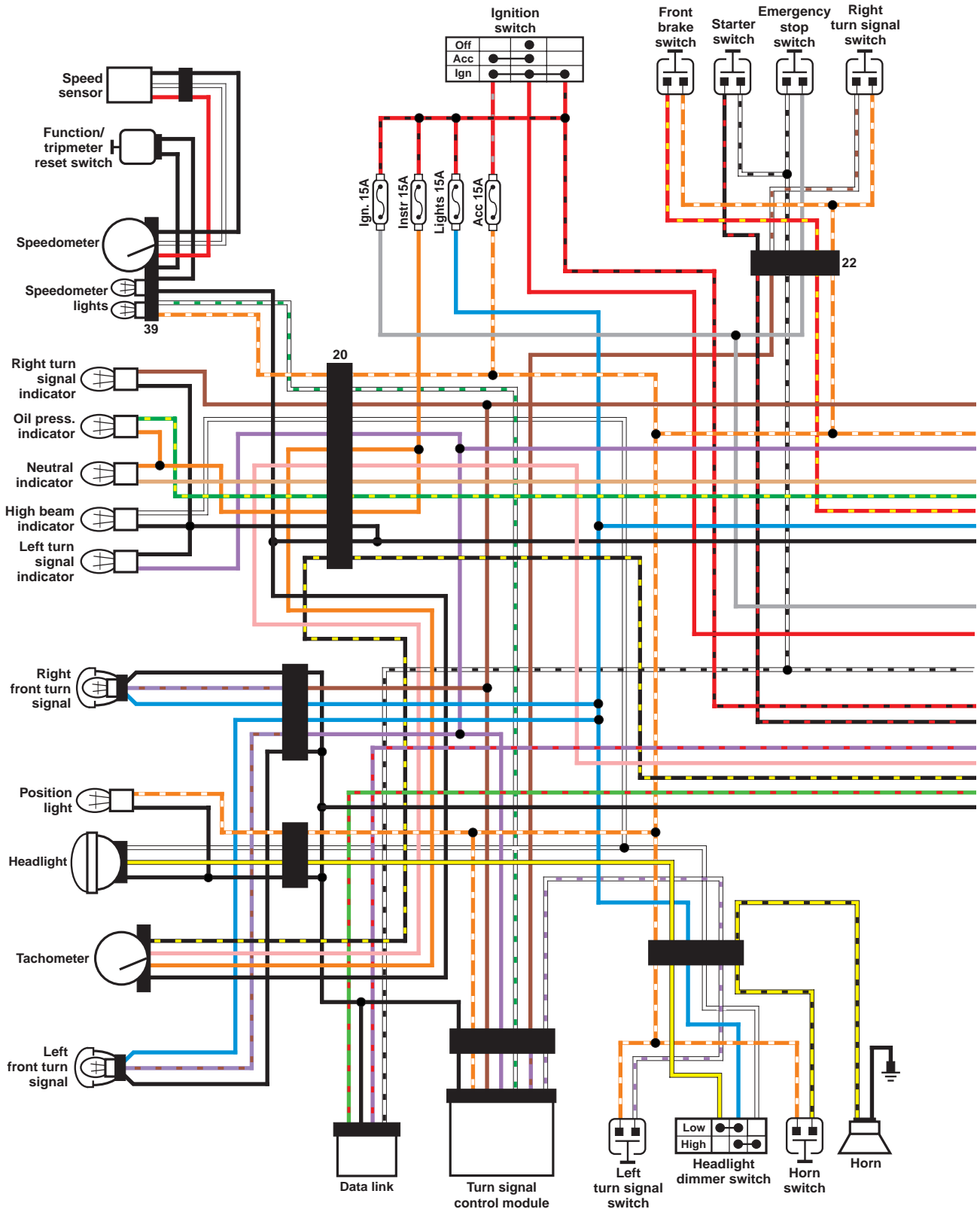

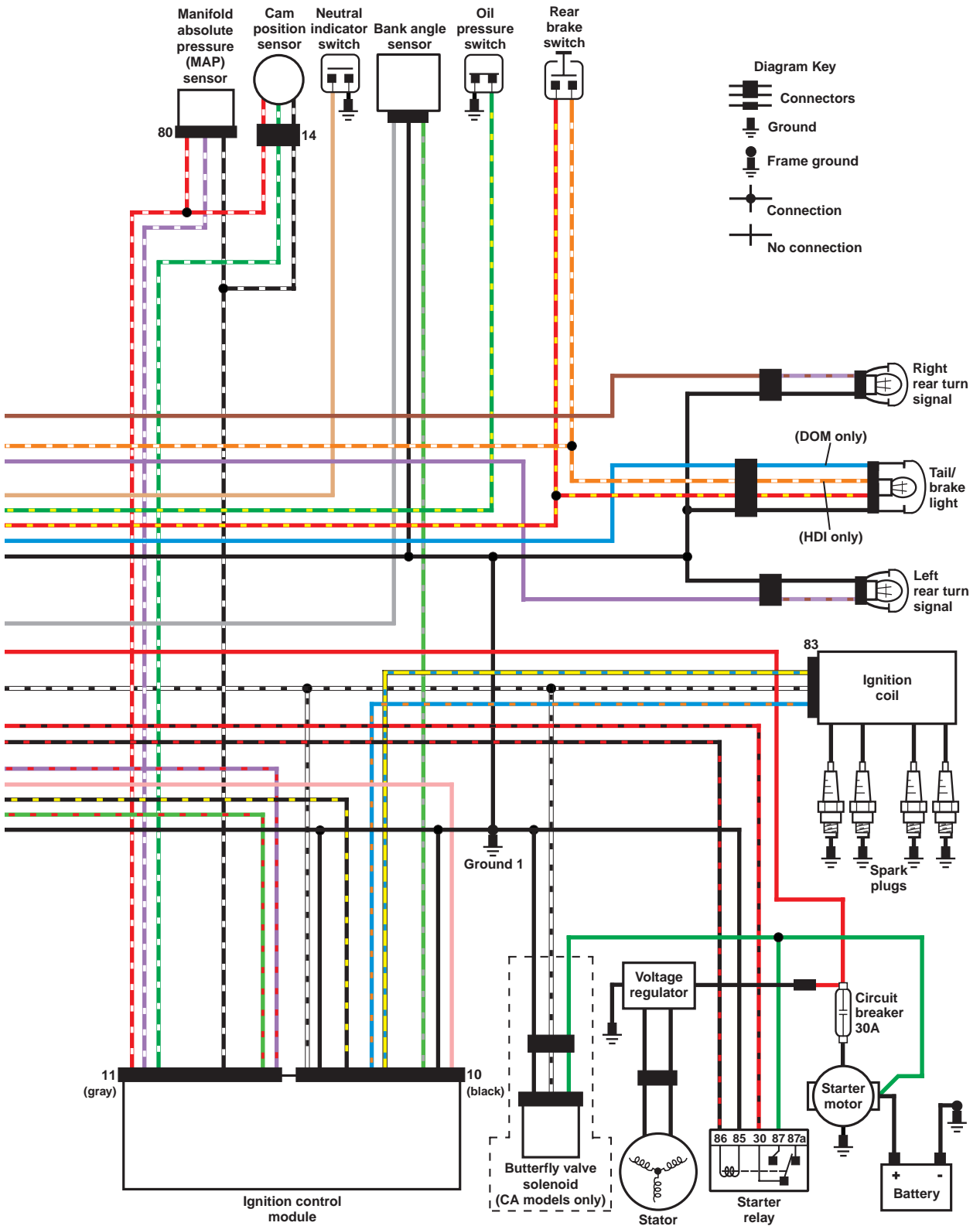

1999-2002 ALL MODELS (EXCEPT 1200S MODELS)

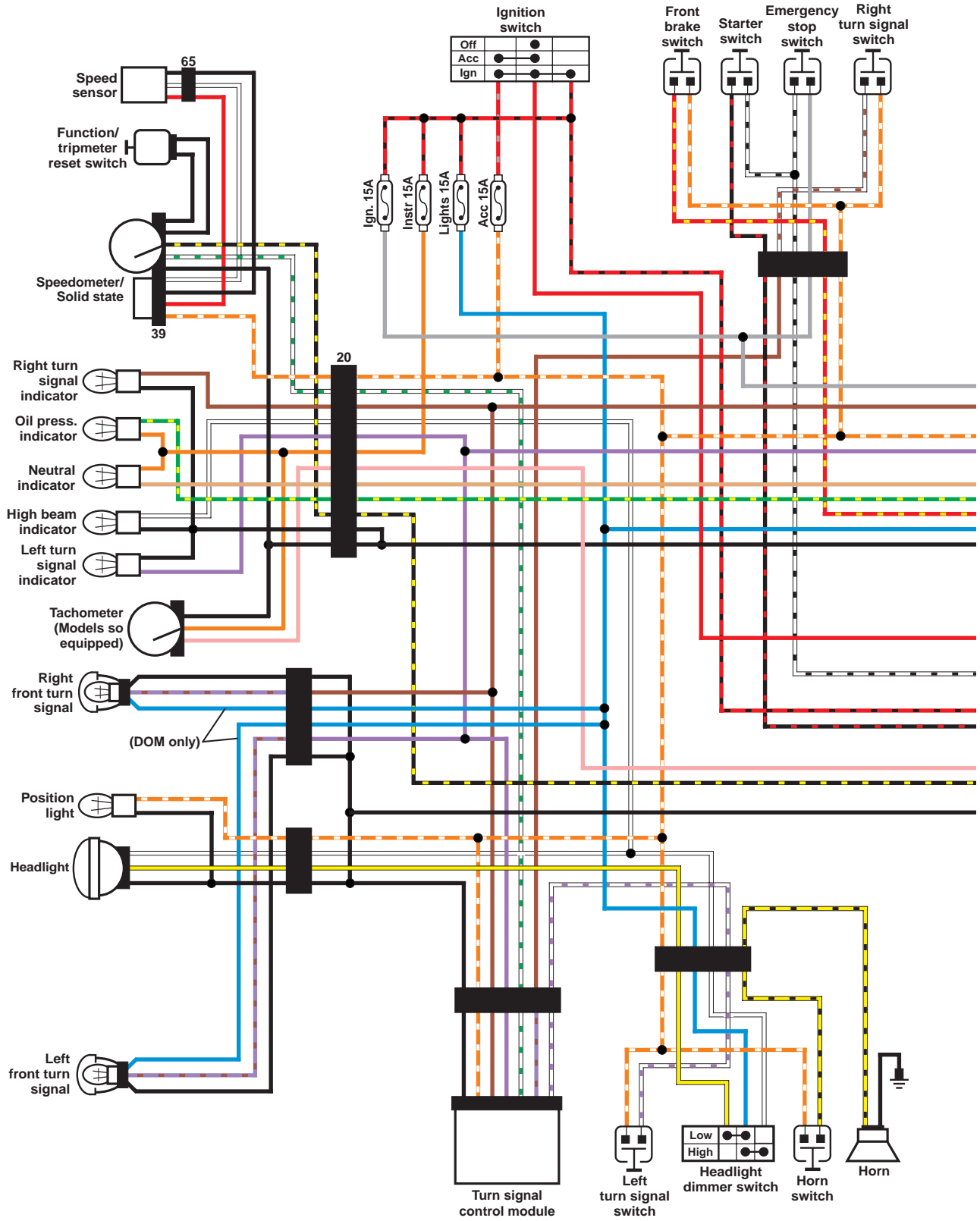

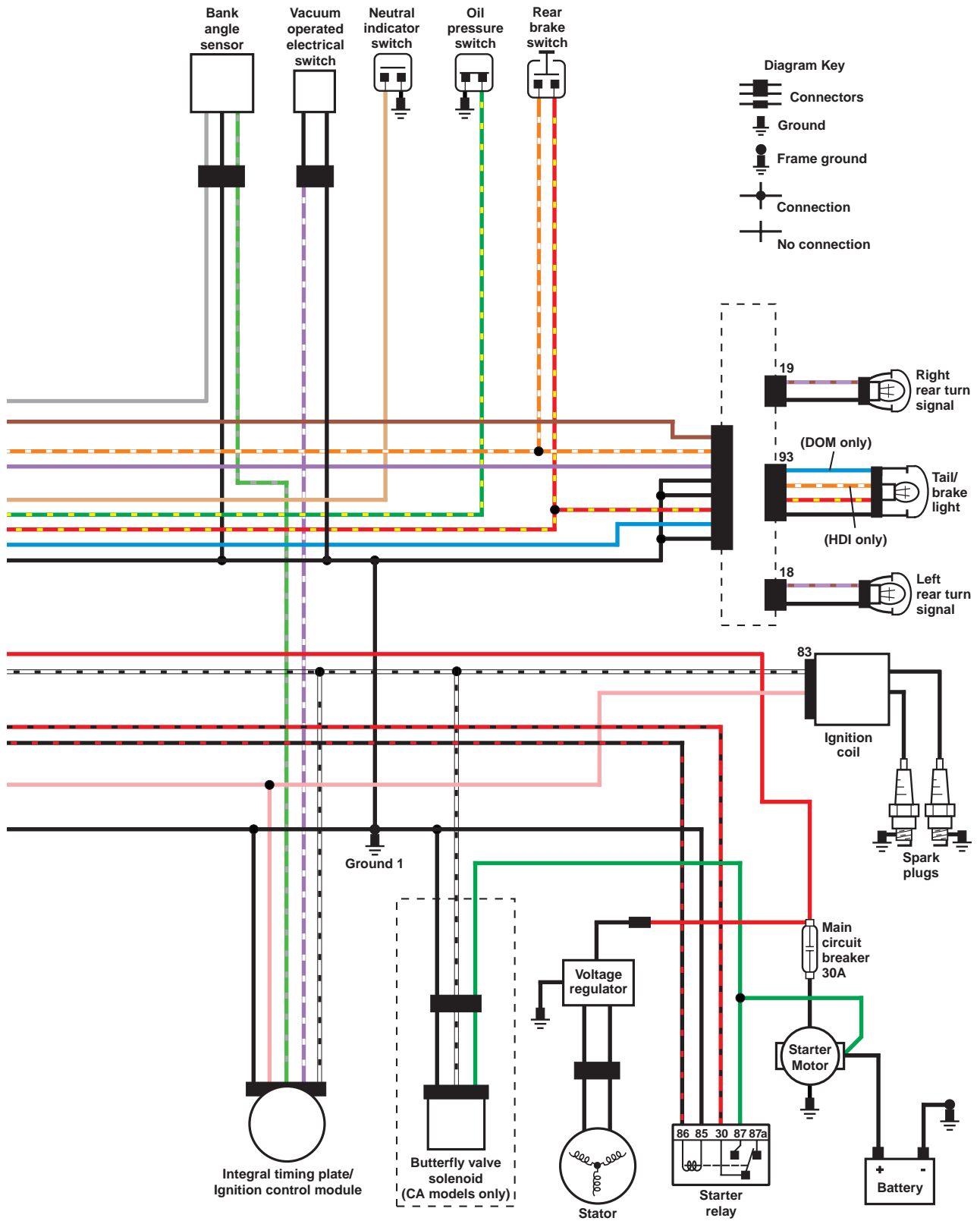

1999-2002 1200S MODELS

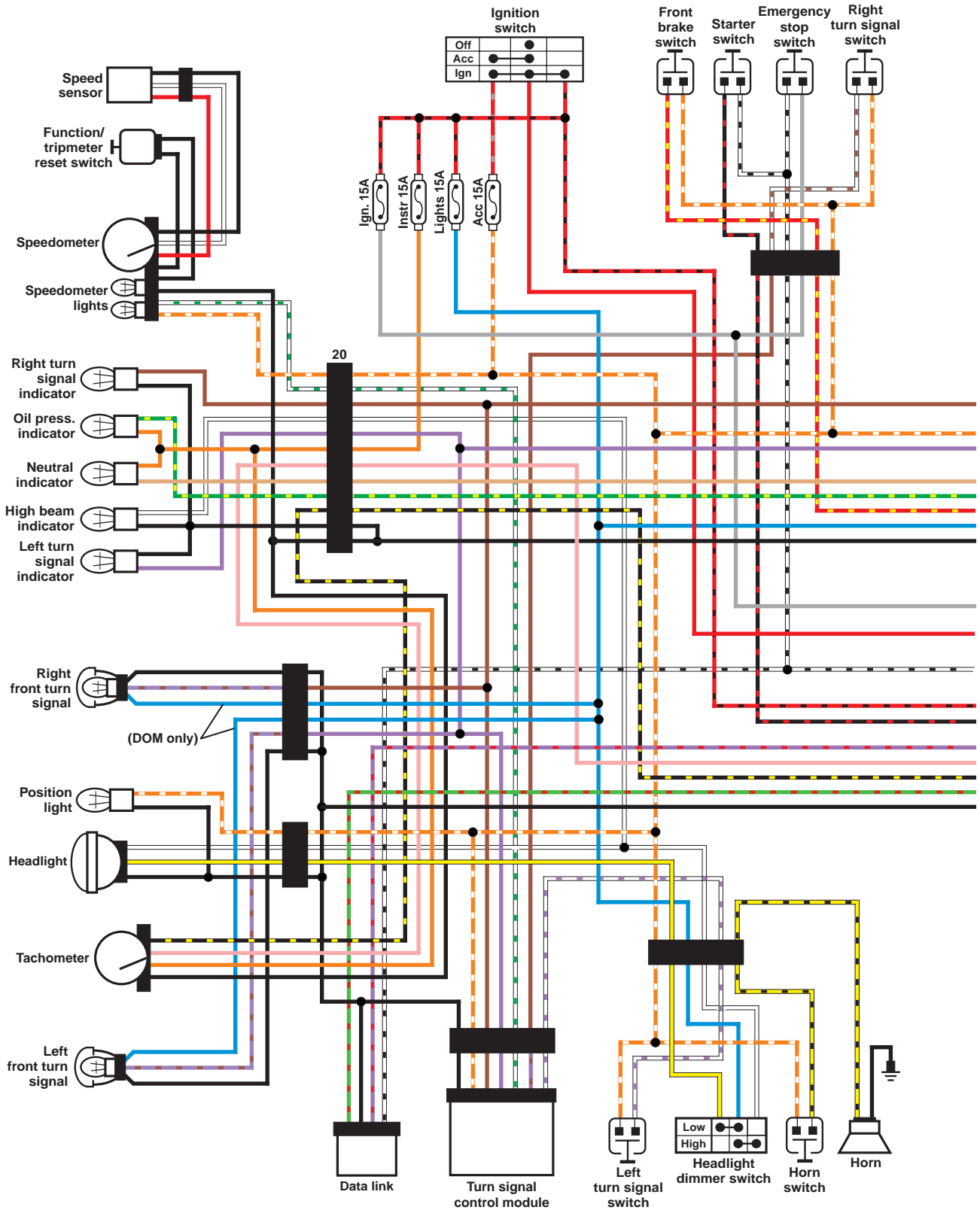

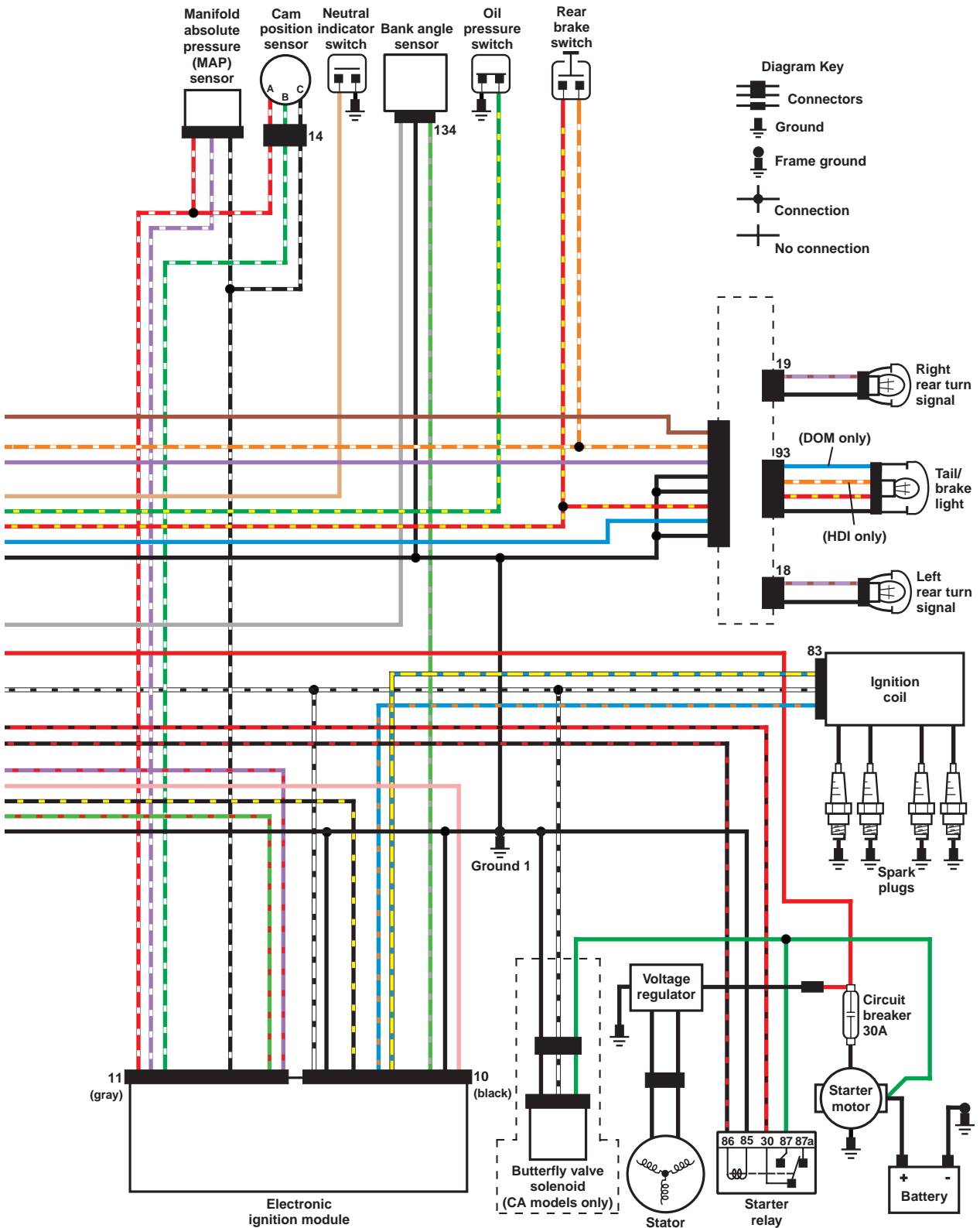

2003 ALL MODELS (EXCEPT 1200S MODELS)

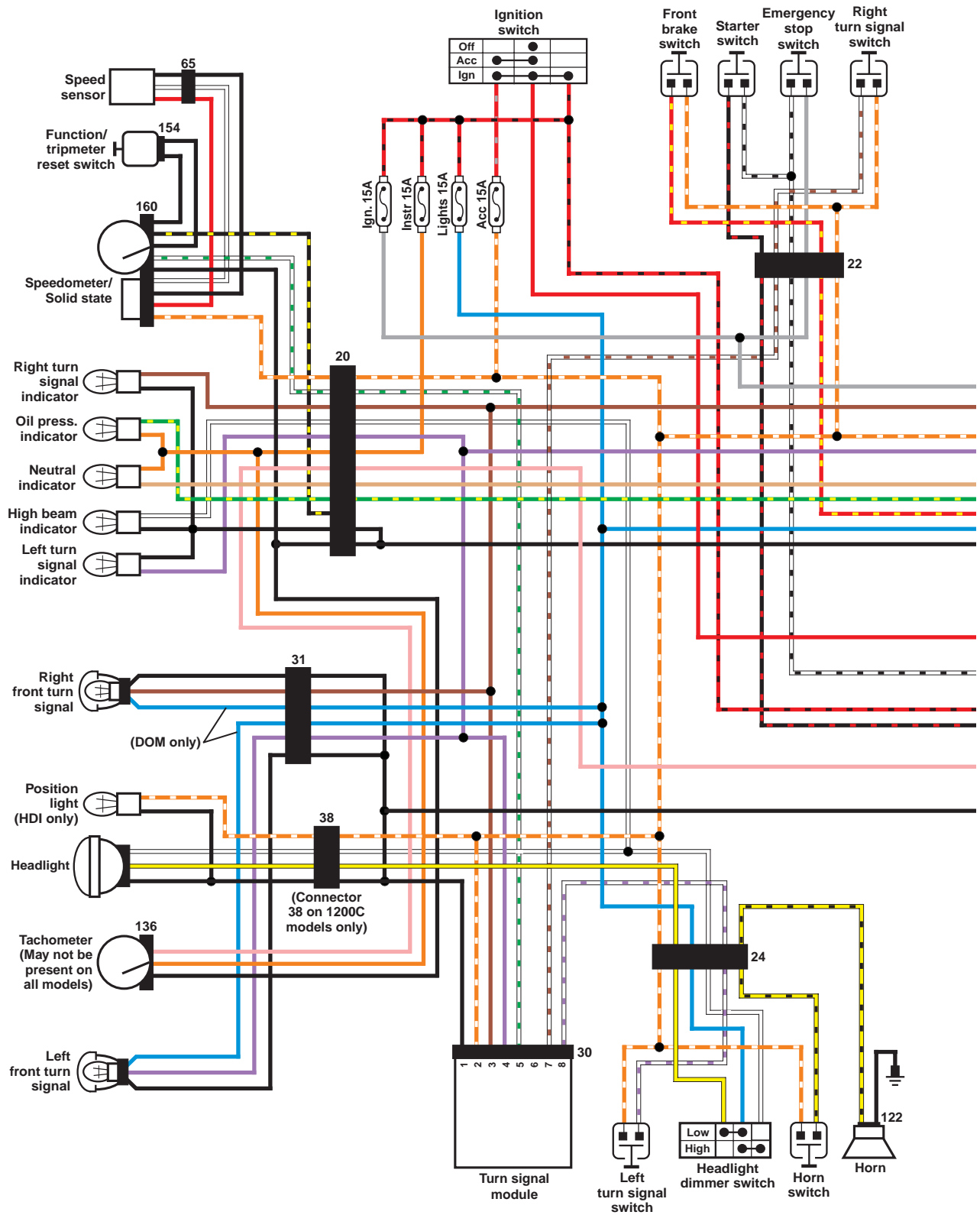

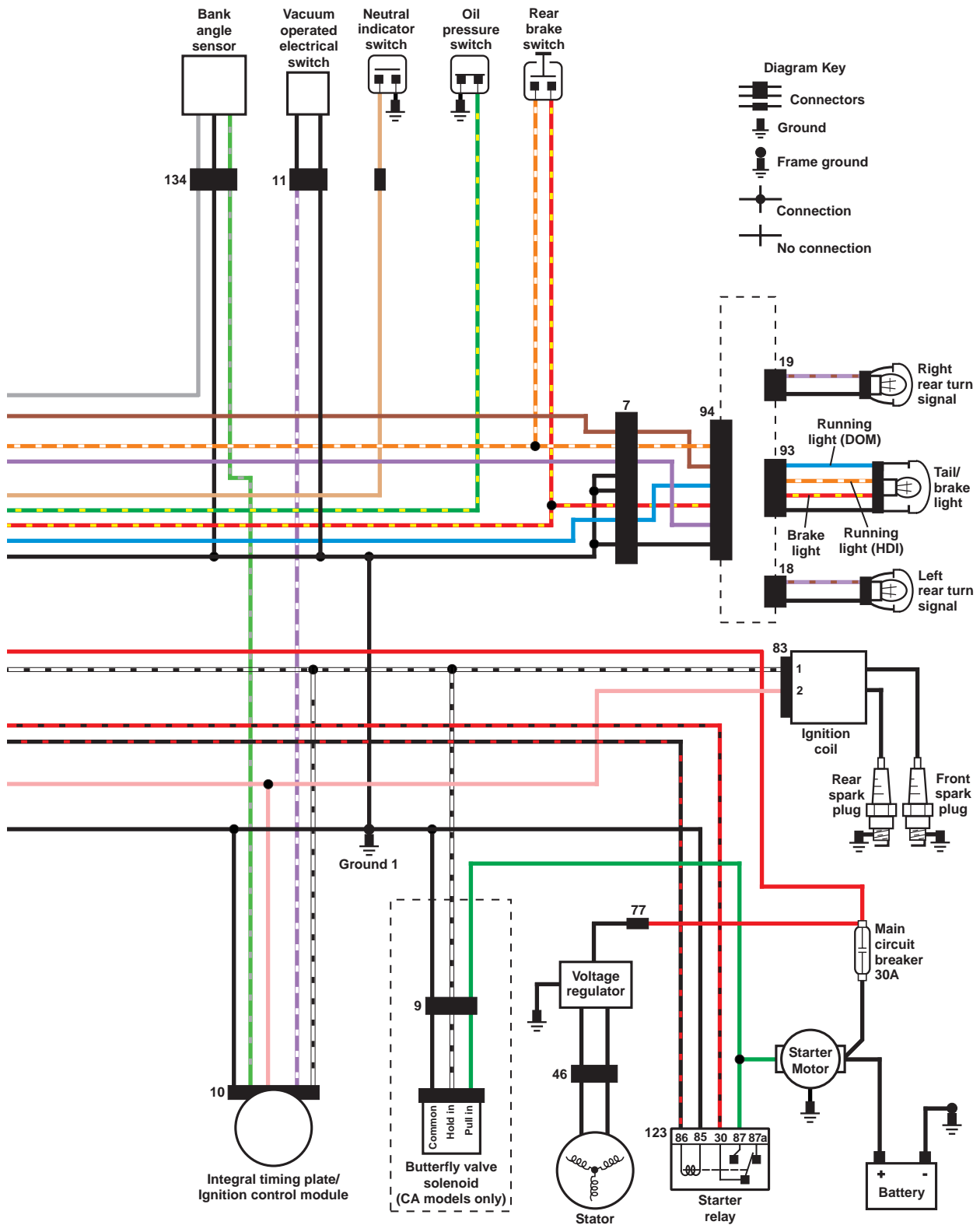

2003 1200S MODELS

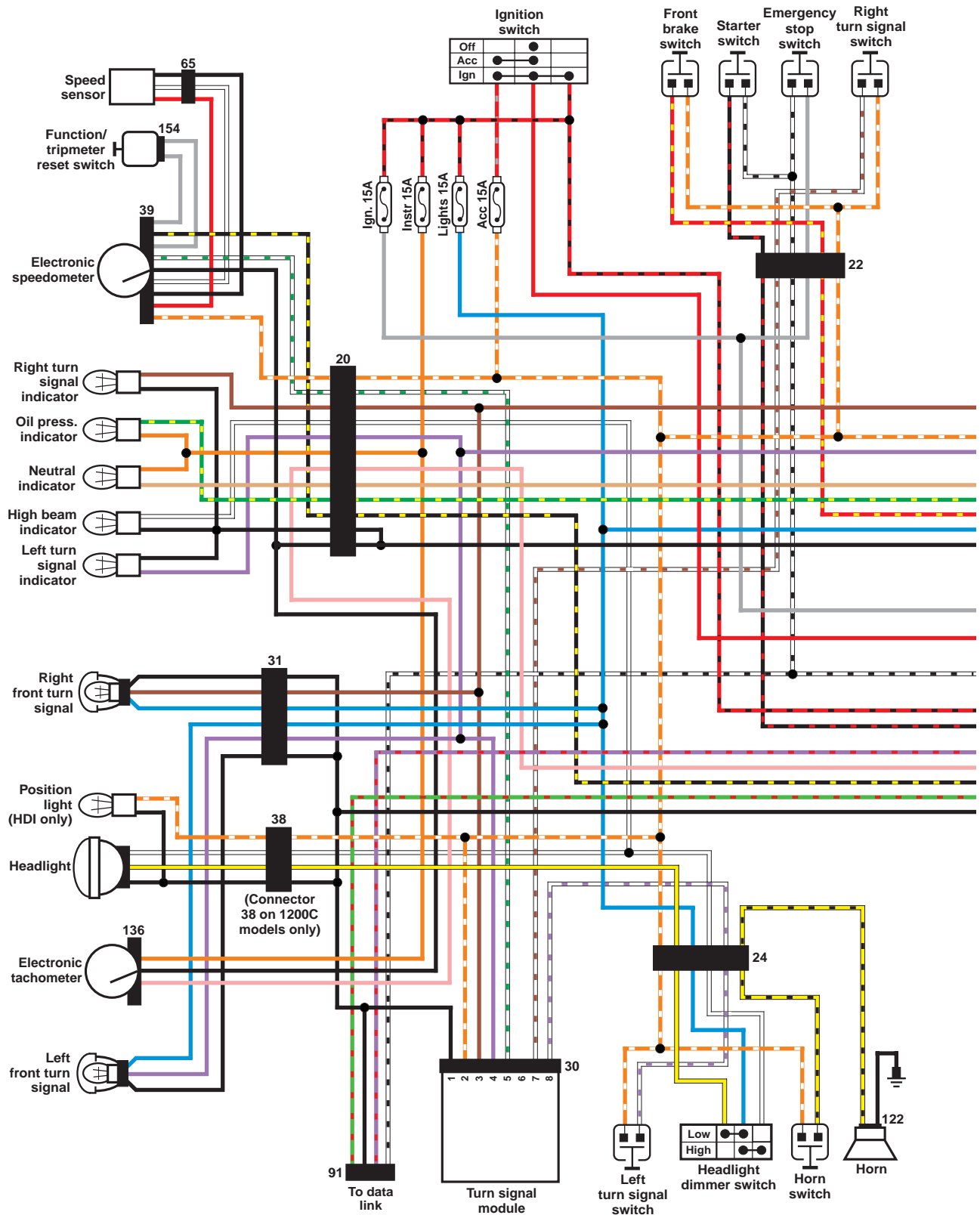

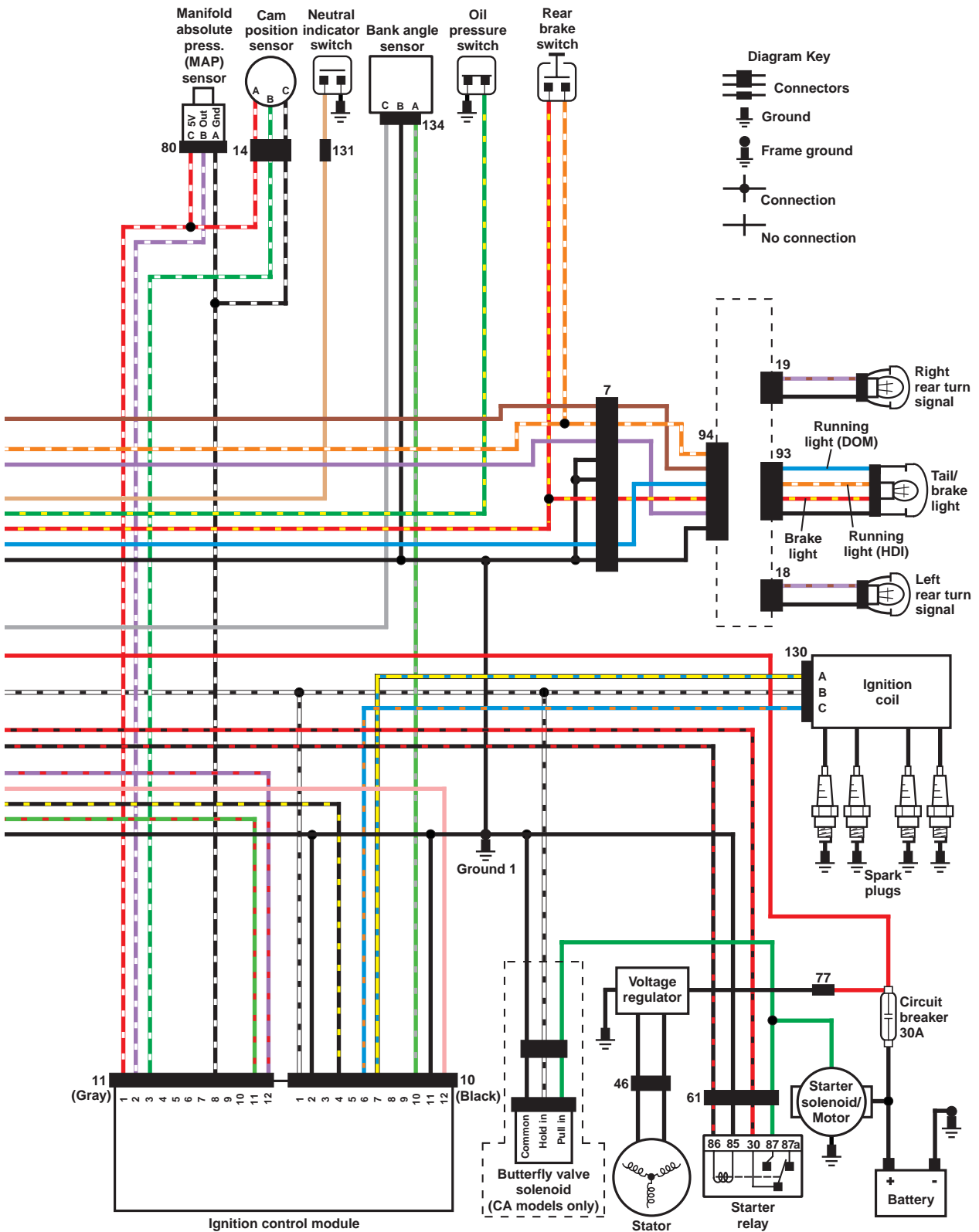

1986 - 2003



SERVICE MANUAL
XL/XLH SPORTSTER
1986 - 2003

| | |
|-----------|---|
| 1 | Chapter One General Information |
| 2 | Chapter Two Troubleshooting |
| 3 | Chapter Three Periodic Lubrication, Maintenance & Tune-up |
| 4 | Chapter Four Engine Top End |
| 5 | Chapter Five Engine Lower End |
| 6 | Chapter Six Primary Drive & Clutch (1986-1990 Models) |
| 7 | Chapter Seven Primary Drive & Clutch (1991-2003 Models) |
| 8 | Chapter Eight 4-Speed Transmission (1986-1990 Models) |
| 9 | Chapter Nine 5-Speed Transmission (1991-2003 Models) |
| 10 | Chapter Ten Fuel, Emission Control & Exhaust Systems (1986-1987 Models) |
| 11 | Chapter Eleven Fuel, Emission Control & Exhaust Systems (1988-2003 Models) |
| 12 | Chapter Twelve Electrical System |
| 13 | Chapter Thirteen Wheels, Tires & Secondary Drive |
| 14 | Chapter Fourteen Front Suspension & Steering |
| 15 | Chapter Fifteen Rear Suspension |
| 16 | Chapter Sixteen Brakes |
| 17 | Chapter Seventeen Body |
| 18 | Index |
| 19 | Chapter Nineteen Wiring Diagrams |

CONTENTS

| | |
|-----------------------------------|-----------|
| QUICK REFERENCE DATA | IX |
|-----------------------------------|-----------|

CHAPTER ONE

| | |
|----------------------------------|----------|
| GENERAL INFORMATION | 1 |
|----------------------------------|----------|

| | |
|------------------------------|--------------------------------|
| Manual organization | Tools |
| Warnings, cautions and notes | Measuring tools |
| Safety | Electrical system fundamentals |
| Serial numbers | Service methods |
| Fasteners | Storage |
| Shop supplies | |

CHAPTER TWO

| | |
|------------------------------|-----------|
| TROUBLESHOOTING | 32 |
|------------------------------|-----------|

| | |
|--|---------------------------------------|
| Starting the engine | Leakdown test |
| Engine performance | Engine lubrication |
| Electrical component replacement | Clutch |
| Starting system | Transmission |
| Charging system | Electrical testing |
| Ignition system (1986-1997 models) | Electronic speedometer/tachometer |
| Ignition system (1998-2003 models, except 1200S models) | Turn signal module (1991-1996 models) |
| Ignition system (1998-2003 1200S models) | Turn signal module (1997-2003 models) |
| Fuel system | Excessive vibration |
| Engine noises | Front suspension and steering |
| Engine smoke | Brake problems |

CHAPTER THREE

| | |
|---|------------|
| LUBRICATION, MAINTENANCE AND TUNE-UP | 113 |
|---|------------|

| | |
|-----------------------|----------------------------|
| Fuel type | Tune-up |
| Maintenance schedule | Air filter |
| Routine safety checks | Compression test |
| Tires and wheels | Spark plugs |
| Periodic lubrication | Ignition timing adjustment |
| Periodic maintenance | |

CHAPTER FOUR

ENGINE TOP END 151

| | |
|-----------------------------|--------------------------|
| Tools | Pushrods and covers |
| Rocker cover assembly | Cylinder |
| Cylinder head | Pistons and piston rings |
| Valves and valve components | Oil tank and oil lines |

CHAPTER FIVE

ENGINE LOWER END 197

| | |
|---|-------------------------------------|
| Tools | Oil pump (1986-1990 models) |
| Engine service | Oil pump (1991-2003 models) |
| Engine stand | Oil filter mount (1986-1990 models) |
| Engine | Oil filter mount (1991-2003 models) |
| Valve tappets and guides (1986-1990 models) | Crankcase and crankshaft |
| Valve tappets (1991-2003 models) | Cylinder studs |
| Gearcase cover and timing gears | Engine break-in |

CHAPTER SIX

PRIMARY DRIVE AND CLUTCH (1986-1990 MODELS) 251

| | |
|--------------------------|----------------------|
| Primary drive cover | Primary drive/clutch |
| Clutch release mechanism | Clutch cable |
| Primary chain adjuster | |

CHAPTER SEVEN

PRIMARY DRIVE AND CLUTCH (1991-2003 MODELS) 264

| | |
|---|------------------------|
| Primary drive cover (1991-1993 models) | Primary chain adjuster |
| Primary drive cover (1994-2003 models) | Primary drive/clutch |
| Clutch release mechanism (1991-1993 models) | Clutch cable |
| Clutch release mechanism (1994-2003 models) | |

CHAPTER EIGHT

FOUR-SPEED TRANSMISSION (1986-1990 MODELS) 284

| | |
|--------------|-------------------|
| Transmission | Shifter mechanism |
|--------------|-------------------|

CHAPTER NINE

FIVE-SPEED TRANSMISSION (1991-2003 MODELS) 304

| | |
|----------------------------|----------------------------------|
| Transmission | Access door bearings |
| Shift forks and shift drum | Right transmission case bearings |
| Mainshaft and countershaft | Shift mechanism |
| Main drive gear | |

CHAPTER TEN

FUEL, EMISSION CONTROL AND EXHAUST SYSTEMS (1986-1987 MODELS) 333

| | |
|--------------------------|--|
| Air filter backplate | Fuel tank |
| Carburetor | Fuel shutoff valve |
| Intake manifold | Exhaust system |
| Fuel hose and clamps | Evaporative emission control system (California models) |
| Throttle and idle cables | |
| Choke cable | |

CHAPTER ELEVEN

FUEL, EMISSION CONTROL AND EXHAUST SYSTEMS (1988-2003 MODELS) 350

| | |
|--|--|
| Air filter backplate | Fuel tank |
| Carburetor | Fuel shutoff valve (1988-1994 models) |
| Intake manifold | Fuel shutoff valve (1995-2003 models) |
| Fuel hose and clamps | Exhaust system (all models except 883R models) |
| Throttle and idle cables | Exhaust system (883R models) |
| Starting enrichment valve (choke) cable | Evaporative emission control system (California models) |

CHAPTER TWELVE

ELECTRICAL SYSTEM 392

| | |
|---|--|
| Electrical component replacement | Starter |
| Electrical connectors | Starter solenoid |
| Battery (1986-1996 models) | Lighting system |
| Battery (1997-2003 models) | Electronic speedometer/tachometer |
| Charging system | Switches |
| Alternator (1986-1990 models) | Horn |
| Alternator (1991-2003 models) | Electrical bracket |
| Ignition system (1986-1997 models) | Turn signal flasher (1986-1990 models) |
| Ignition system (1998-2003, all models except 1200S models) | Turn signal module (1991-2003 models) |
| Ignition system (1998-2003 1200S models) | Circuit breakers (1986-1997 models) |
| Ignition coil | Fuses (1998-2003 models) |
| Bank angle sensor (1998-2003 models) | Electrical connectors |
| Manifold absolute pressure (MAP) sensor (1998-2003 1200S models) | Wiring diagrams |

CHAPTER THIRTEEN

WHEELS, TIRES AND SECONDARY DRIVE 466

| | |
|------------------------------|---------------------------|
| Motorcycle stands | Drive chain and sprockets |
| Front wheel | Drive belt and sprockets |
| Front hub (1986-1999 models) | Wheel runout |
| Front hub (2000-2003 models) | Laced wheels |
| Rear wheel | Disc and cast wheels |
| Rear hub (1986-1999 models) | Wheel balance |
| Rear hub (2000-2003 models) | Tires |

CHAPTER FOURTEEN

FRONT SUSPENSION AND STEERING 500

| | |
|---|--------------------------|
| Handlebar | Steering head and stem |
| Front fork (all models except 1200S models) | Steering head bearing |
| Front fork (1200S models) | Steering play adjustment |

| | | |
|--|--|------------|
| CHAPTER FIFTEEN | | |
| REAR SUSPENSION | | 526 |
| Shock absorbers | Swing arm | |
| | | |
| CHAPTER SIXTEEN | | |
| BRAKES | | 533 |
| Brake fluid selection | Rear brake caliper (1986-early 1987 models) | |
| Brake service | Rear brake caliper (late 1987-1999 models) | |
| Front brake pads (1986-1999 models) | Rear brake caliper (2000-2003 models) | |
| Front brake pads (2000-2003 models) | Rear master cylinder (1986-early 1987 models) | |
| Front brake caliper (1986-1999 models) | Rear master cylinder (late 1987-2003 models) | |
| Front brake caliper (2000-2003 models) | Brake hose and line replacement | |
| Front master cylinder (1986-1995 models) | Brake disc | |
| Front master cylinder (1996-2003 models) | Bleeding the system | |
| Rear brake pads (1986-early 1987 models) | Brake fluid draining | |
| Rear brake pads (late 1987-1999 models) | Flushing the brake system | |
| Rear brake pads (2000-2003 models) | | |
| | | |
| CHAPTER SEVENTEEN | | |
| BODY | | 590 |
| Seat | Forward foot controls (1999-2003 883C and 1200C models) | |
| Front fender | Sidestand | |
| Rear fender | Fork lock | |
| Footrests | | |
| | | |
| INDEX | | 601 |
| | | |
| WIRING DIAGRAMS | | 606 |

QUICK REFERENCE DATA

MOTORCYCLE DATA

| | |
|--|--------------------|
| MODEL: _____ | YEAR: _____ |
| VIN NUMBER: _____ | |
| ENGINE SERIAL NUMBER: _____ | |
| CARBURETOR SERIAL NUMBER: _____ | |

TIRE INFLATION PRESSURE (COLD)¹

| | psi | kPa |
|--------------------------------------|-----|-----|
| Up to 300 lb. load ² | | |
| Front | | |
| 1200 models | 30 | 207 |
| 883 and 1100 models | | |
| 1986-1990 | 26 | 179 |
| 1991-2003 | 30 | 207 |
| Rear | | |
| 1200 models | 36 | 248 |
| 883 and 1100 models | | |
| 1986-1990 | 30 | 207 |
| 1991-2003 | 36 | 248 |
| Up to GVWR maximum load ³ | | |
| Front | | |
| 1200 models | 30 | 207 |
| 883 and 1100 models | | |
| 1986-1990 | 26 | 179 |
| 1991-2003 | 30 | 207 |
| Rear | | |
| 1200 models | 40 | 276 |
| 883 and 1100 models | | |
| 1986-1990 | 32 | 221 |
| 1991-2003 | 40 | 276 |

1. Tire inflation pressure is for original equipment tires. Aftermarket tires may require a different inflation pressure.
2. 300 lb. load includes rider, passenger and cargo.
3. The gross vehicle weight rating (GVWR) is listed on a decal mounted on the frame.

ENGINE OIL SPECIFICATIONS

| Type | HD rating | Viscosity | Ambient operating temperature |
|-------------------|-----------|------------|-------------------------------|
| HD Multi-grade | HD360 | SAE 10W/40 | Below 40° F |
| HD Multi-grade | HD360 | SAE 20W/50 | Above 40° F |
| HD Regular heavy* | HD360 | SAE 50 | Above 60° F |
| HD Extra heavy* | HD360 | SAE 60 | Above 80° F |

*Not recommended for use when ambient temperature is below 50° F.

ENGINE AND PRIMARY DRIVE/TRANSMISSION OIL CAPACITIES

| | |
|--|-----------------|
| Oil tank refill capacity with filter replacement | 3.0 qt. (2.8 L) |
| Transmission (includes primary chaincase) | |
| 1986-1992 models | 24 oz. (710 ml) |
| 1993-2003 models | 32 oz. (946 ml) |

RECOMMENDED LUBRICANTS AND FLUIDS

| | |
|----------------------|--|
| Brake fluid | DOT 5 |
| Chain lubricant | |
| Standard drive chain | H-D Chain Spray or HD High-Performance Chain Lube |
| O-ring drive chain | H-D High-Performance Chain Lube or automotive lubricant rated API GL-5 with a viscosity index of SAE 80 or 90. |
| Front fork oil | H-D Type E or equivalent |
| Fuel | |
| Type | Unleaded |
| Octane | |
| 1986-1990 models | Pump research octane of 89 or higher |
| 1991-2003 models | Pump research octane of 87 or higher |
| Transmission | H-D Sport Trans Fluid or equivalent |

MAINTENANCE AND TUNE UP TORQUE SPECIFICATIONS

| Item | ft.-lb. | in.-lb. | N•m |
|---|---------|---------|-----------|
| Air filter cover | – | 36-60 | 4.1-6.8 |
| Front fork cap to fork tube* | 11-22 | – | 15-30 |
| Primary chain adjuster locknut | | | |
| 1986-1990 models | – | 98-144 | 11.1-16.3 |
| 1991-2003 models | 20-25 | – | 27-34 |
| Primary cover retainin screws | – | 84-108 | 10-12 |
| Rear axle nut | 60-65 | – | 81-88 |
| Spark plug | 11-18 | – | 15-24 |
| Transmission/primary chaincase drain plug | 14-21 | – | 19-28 |

*1200S. Other models no specification available.

MAINTENANCE AND TUNE-UP SPECIFICATIONS

| Item | Specification |
|-------------------------------|------------------------------------|
| Brake pad minimum thickness | 0.062 in. (1.59 mm) |
| Clutch cable free play | 1/16-1/8 in. (1.6-3.2 mm) |
| Drive belt deflection | |
| 1991-1999 models | 9/16-11/16 in. (14.3-17.5 mm) |
| 2000-2003 models | |
| 883, 1200, 1200S models | 5/16-3/8 in. (7.9-9.6 mm) |
| 883H and 883C models | 1/4-5/16 in. (6.4-7.9 mm) |
| Drive chain | No. 530 (3/8 in. wide) × 110 links |
| Drive chain free play* | 1/4 in. (6.4 mm) |
| Engine compression (min.) | 120 psi (828 kPa) |
| Idle speed | |
| 1986-1987 models | |
| Slow idle | 900-950 rpm |
| Fast idle | 1500-1500 rpm |
| 1988-2003 models | 1000-1050 rpm |
| Primary chain free play | |
| Cold engine | 3/8-1/2 in. (9.6-12.7 mm) |
| Hot engine | 1/4-3/8 in. (6.4-9.6 mm) |
| Spark plugs | HD-6R12 |
| Gap | 0.038-0.043 in. (0.97-1.09 mm) |
| Tire wear/maximum tread depth | 1/16 in. (1.6 mm) |

*Rider on seat.